

HIGH-SPEED DIFFERENTIAL LINE DRIVER/RECEIVERS

FEATURES

- Meets or Exceeds the ANSI TIA/EIA-644A Standard
- Designed for Signaling Rates

The signaling rate of a line is the number of voltage transitions that are made per second expressed in the units bps (bits per second)

up to:

- 630 Mbps Drivers
- 400 Mbps Receivers
- Operates From a 2.4-V to 3.6-V Supply
- Available in SOT-23 and SOIC Packages
- Bus-Terminal ESD Exceeds 9 kV
- Low-Voltage Differential Signaling With Typical Output Voltages of 350 mV Into a 100-Ω Load
- Propagation Delay Times
 - 1.7 ns Typical Driver
 - 2.5 ns Typical Receiver
- Power Dissipation at 200 MHz
 - 25 mW Typical Driver
 - 60 mW Typical Receiver
- LVDT Receiver Includes Line Termination
- Low Voltage TTL (LVTTTL) Level Driver Input Is 5-V Tolerant
- Driver Is Output High Impedance With $V_{CC} < 1.5 V$
- Receiver Output and Inputs Are High Impedance With $V_{CC} < 1.5 V$
- Receiver Open-Circuit Fail Safe
- Differential Input Voltage Threshold Less Than 100 mV

DESCRIPTION

The SN65LVDS1, SN65LVDS2, and SN65LVDT2 are single, low-voltage, differential line drivers and receivers in the small-outline transistor package. The outputs comply with the TIA/EIA-644A standard and provide a minimum differential output voltage magnitude of 247 mV into a 100-Ω load at signaling rates up to 630 Mbps for drivers and 400 Mbps for receivers.

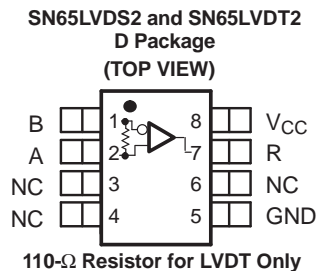
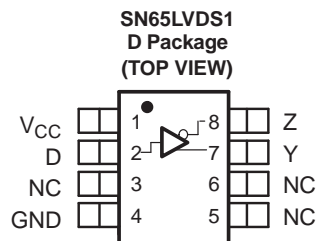
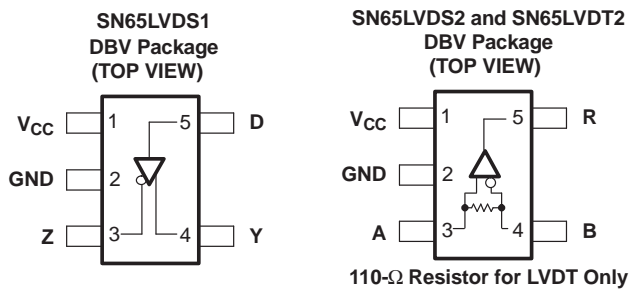

AVAILABLE OPTIONS

PART NUMBER	INTEGRATED TERMINATION	PACKAGE	PACKAGE MARKING
SN65LVDS1DBV		SOT23-5	SAAI
SN65LVDS1D		SOIC-8	LVDS1
SN65LVDS2DBV		SOT23-5	SABI
SN65LVDS2D		SOIC-8	LVDS2
SN65LVDT2DBV	√	SOT23-5	SACI
SN65LVDT2D	√	SOIC-8	LVDT2



Please be aware that an important notice concerning availability, standard warranty, and use in critical applications of Texas Instruments semiconductor products and disclaimers thereto appears at the end of this data sheet.



These devices have limited built-in ESD protection. The leads should be shorted together or the device placed in conductive foam during storage or handling to prevent electrostatic damage to the MOS gates.

DESCRIPTION CONTINUED

When the SN65LVDS1 is used with an LVDS receiver (such as the SN65LVDT2) in a point-to-point connection, data or clocking signals can be transmitted over printed-circuit-board traces or cables at very high rates with very low electromagnetic emissions and power consumption. The packaging, low power, low EMI, high ESD tolerance, and wide supply voltage range make the device ideal for battery-powered applications.

The SN65LVDS1, SN65LVDS2, and SN65LVDT2 are characterized for operation from -40°C to 85°C .

FUNCTION TABLES

DRIVER			RECEIVER	
INPUT	OUTPUTS		INPUTS	OUTPUT
D	Y	Z	$V_{ID} = V_A - V_B$	R
H	H	L	$V_{ID} \geq 100 \text{ mV}$	H
L	L	H	$-100 \text{ mV} < V_{ID} < 100 \text{ mV}$?
Open	L	H	$V_{ID} \leq -100 \text{ mV}$	L
			Open	H

H = high level, L = low level, ? = indeterminate

DRIVER EQUIVALENT INPUT AND OUTPUT SCHEMATIC DIAGRAMS

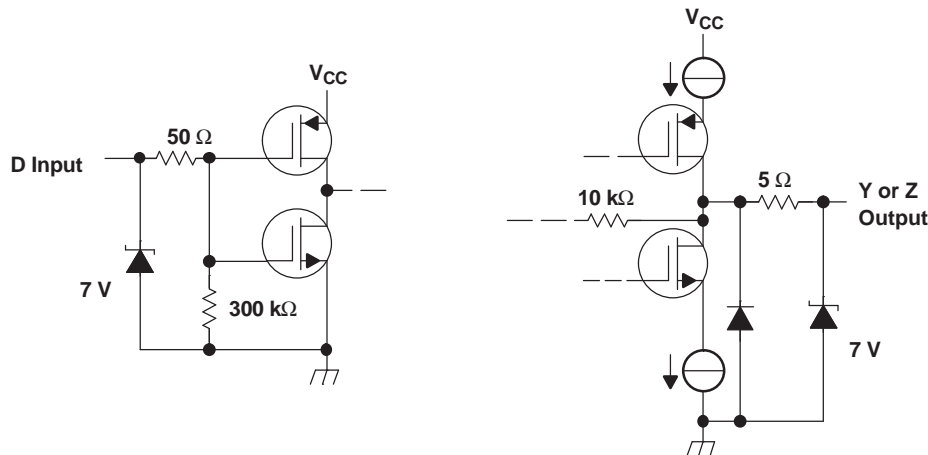

RECEIVER EQUIVALENT INPUT AND OUTPUT SCHEMATIC DIAGRAMS

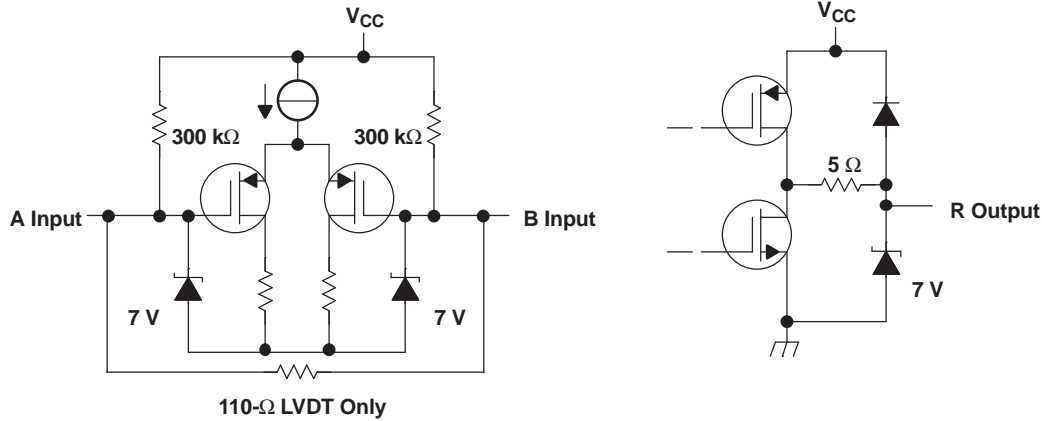

ABSOLUTE MAXIMUM RATINGS

over operating free-air temperature range (unless otherwise noted)⁽¹⁾

PARAMETER		RATINGS
Supply voltage range, V_{CC} ⁽²⁾		-0.5 V to 4 V
Input voltage range, V_I	(A or B)	-0.5 V to 4 V
	(D)	-0.5 V to $V_{CC} + 2$ V
Output voltage, V_O	(Y or Z)	-0.5 V to 4 V
Differential input voltage magnitude, $ V_{ID} $	SN65LVDT2 only	1 V
Receiver output current, I_O		-12 mA to 12 mA
Human-body model electrostatic discharge, HBM ESD ⁽³⁾		
	All pins	4000 V
	Bus pins (A, B, Y, Z)	9000 V
Machine-model electrostatic discharge, MM ESD ⁽⁴⁾		400 V
Field-induced-charge device model electrostatic discharge, FCDM ESD ⁽⁵⁾		1500 V
Continuous total power dissipation, P_D		See Dissipation Rating Table
Storage Temperature Range (non operating)		-65°C to 150°C

- (1) Stresses beyond those listed under absolute maximum ratings may cause permanent damage to the device. These are stress ratings only, and functional operation of the device at these or any other conditions beyond those indicated under recommended operating conditions is not implied. Exposure to absolute-maximum-rated conditions for extended periods may affect device reliability.
- (2) All voltage values, except differential I/O bus voltages are with respect to network ground terminal.
- (3) Test method based upon JEDEC Standard 22, Test Method A114-A. Bus pins stressed with respect to GND and V_{CC} separately.
- (4) Test method based upon JEDEC Standard 22, Test Method A114-A.
- (5) Test method based upon EIA-JEDEC JESD22-C101C.

DISSIPATION RATING TABLE

PACKAGE	$T_A \leq 25^\circ\text{C}$ POWER RATING	DERATING FACTOR ABOVE $T_A = 25^\circ\text{C}$ ⁽¹⁾	$T_A = 85^\circ\text{C}$ POWER RATING
D	725 mW	5.8 mW/°C	402 mW
DBV	385 mW	3.1 mW/°C	200 mW

- (1) This is the inverse of the junction-to-ambient thermal resistance when board-mounted (low-K) and with no air flow.

RECOMMENDED OPERATING CONDITIONS

PARAMETER		MIN	NOM	MAX	UNIT
V_{CC}	Supply voltage	2.4	3.3	3.6	V
V_{IH}	High-level input voltage	2		5	V
V_{IL}	Low-level input voltage	0		0.8	V
T_A	Operating free-air temperature	–40		85	°C
$ V_{ID} $	Magnitude of differential input voltage	0.1		0.6	V
	Input voltage (any combination of input or common-mode voltage)	0		$V_{CC}-0.8$	V

DRIVER ELECTRICAL CHARACTERISTICS

over recommended operating conditions (unless otherwise noted)

PARAMETER		TEST CONDITIONS	MIN ⁽¹⁾	TYP ⁽²⁾	MAX	UNIT
V _{OD}	Differential output voltage magnitude	R _L = 100 Ω, 2.4 ≤ V _{CC} < 3 V	200	350	454	mV
		R _L = 100 Ω, 3 ≤ V _{CC} < 3.6 V	247	350	454	
Δ V _{OD}	Change in differential output voltage magnitude between logic states	See Figure 2	–50		50	
V _{OC(SS)}	Steady-state common-mode output voltage	See Figure 2	1.125		1.375	V
ΔV _{OC(SS)}	Change in steady-state common-mode output voltage between logic states		–50		50	mV
V _{OC(PP)}	Peak-to-peak common-mode output voltage			25		100
I _{CC}	Supply current	V _I = 0 V or V _{CC} , No load		2	4	mA
		V _I = 0 V or V _{CC} , R _L = 100 Ω		5.5	8	
I _{IH}	High-level input current	V _{IH} = 5 V		2	20	μA
I _{IL}	Low-level input current	V _{IL} = 0.8 V		2	10	μA
I _{OS}	Short-circuit output current	V _{OY} or V _{OZ} = 0 V		3	10	mA
		V _{OD} = 0 V			10	
I _{O(OFF)}	Power-off output current	V _{CC} = 1.5 V, V _O = 3.6 V	–1		1	μA
C _i	Input capacitance	V _I = 0.4 Sin (4E6πt) + 0.5 V		3		pF

(1) The algebraic convention, in which the least positive (most negative) limit is designated as a minimum, is used in this data sheet.

(2) All typical values are at 25°C and with a 3.3-V supply.

DRIVER SWITCHING CHARACTERISTICS

over recommended operating conditions (unless otherwise noted)

PARAMETER		TEST CONDITIONS	MIN	TYP ⁽¹⁾	MAX	UNIT
t _{PLH}	Propagation delay time, low-to-high-level output	R _L = 100 Ω, C _L = 10 pF, See Figure 5		1.5	3.1	ns
t _{PHL}	Propagation delay time, high-to-low-level output			1.8	3.1	ns
t _r	Differential output signal rise time			0.6	1	ns
t _f	Differential output signal fall time			0.7	1	ns
t _{sk(p)}	Pulse skew (t _{PHL} - t _{PLH}) ⁽²⁾			0.3		

(1) All typical values are at 25°C and with a 3.3-V supply.

 (2) t_{sk(p)} is the magnitude of the time difference between the high-to-low and low-to-high propagation delay times at an output.

RECEIVER ELECTRICAL CHARACTERISTICS

over recommended operating conditions (unless otherwise noted)

PARAMETER		TEST CONDITIONS	MIN ⁽¹⁾	TYP ⁽²⁾	MAX	UNIT	
V _{ITH+}	Positive-going differential input voltage threshold	See Figure 3			100	mV	
V _{ITH-}	Negative-going differential input voltage threshold		-100				
V _{OH}	High-level output voltage	I _{OH} = -8 mA, V _{CC} = 2.4 V	1.9			V	
		I _{OH} = -8 mA, V _{CC} = 3 V	2.4				
V _{OL}	Low-level output voltage	I _{OL} = 8 mA		0.25	0.4	V	
I _{CC}	Supply current	No load, Steady state		4	7	mA	
I _I	Input current (A or B inputs)	LVDS2	V _I = 0 V, other input = 1.2 V	-20		-2	μA
			V _I = 2.2 V, other input = 1.2 V, V _{CC} = 3.0 V		-3	-1.2	
		LVDT2	V _I = 0 V, other input open	-40		-4	
			V _I = 2.2 V, other input open, V _{CC} = 3.0 V		-6	-2.4	
I _{ID}	Differential input current (I _{IA} - I _{IB})	LVDS2	V _{IA} = 2.4 V V _{IB} = 2.3 V	-2		2	μA
I _{I(OFF)}	Power-off input current (A or B inputs)	LVDS2	V _{CC} = 0 V, V _{IA} = V _{IB} = 2.4 V			20	μA
		LVDT2	V _{CC} = 0 V, V _{IA} = V _{IB} = 2.4 V			40	
R _T	Differential input resistance	LVDT2	V _{IA} = 2.4 V V _{IB} = 2.2 V	90	111	132	Ω
C _I	Input Capacitance		V _I = 0.4sin(4E6πt) + 0.5V			5.8	pF
C _O	Output Capacitance		V _I = 0.4sin(4E6πt) + 0.5V			3.4	pF

(1) The algebraic convention, in which the least positive (most negative) limit is designated as a minimum, is used in this data sheet.

(2) All typical values are at 25°C and with a 2.7-V supply.

RECEIVER SWITCHING CHARACTERISTICS

over recommended operating conditions (unless otherwise noted)

PARAMETER		TEST CONDITIONS	MIN	TYP ₁	MAX	UNIT
t _{PLH}	Propagation delay time, low-to-high-level output	C _L = 10 pF, See Figure 6	1.4	2.6	3.6	ns
t _{PHL}	Propagation delay time, high-to-low-level output		1.4	2.5	3.6	ns
t _{sk(p)}	Pulse skew (t _{pHL} - t _{pLH}) ⁽²⁾		0.1	0.6		ns
t _r	Output signal rise time		0.8	1.4		ns
t _f	Output signal fall time		0.8	1.4		ns
t _{r(slew)}	Output slew rate (rising)	V _{CC} = 3.0 V - 3.6 V	2.2	3	5.5	V/ns
		V _{CC} = 2.4 V - 2.7 V	1.5	1.9	2.9	V/ns
t _{f(slew)}	Output slew rate (falling)	V _{CC} = 3.0 V - 3.6 V	2.7	3.8	6	V/ns
		V _{CC} = 2.4 V - 2.7 V	2.1	2.3	3.9	V/ns

(1) All typical values are at 25°C and with a 2.7-V supply.

(2) t_{sk(p)} is the magnitude of the time difference between the high-to-low and low-to-high propagation delay times at an output.

PARAMETER MEASUREMENT INFORMATION

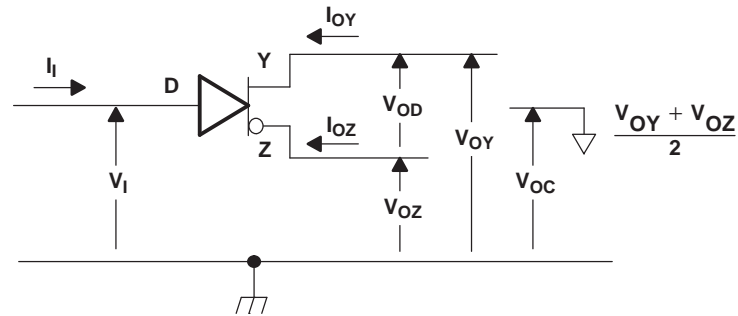
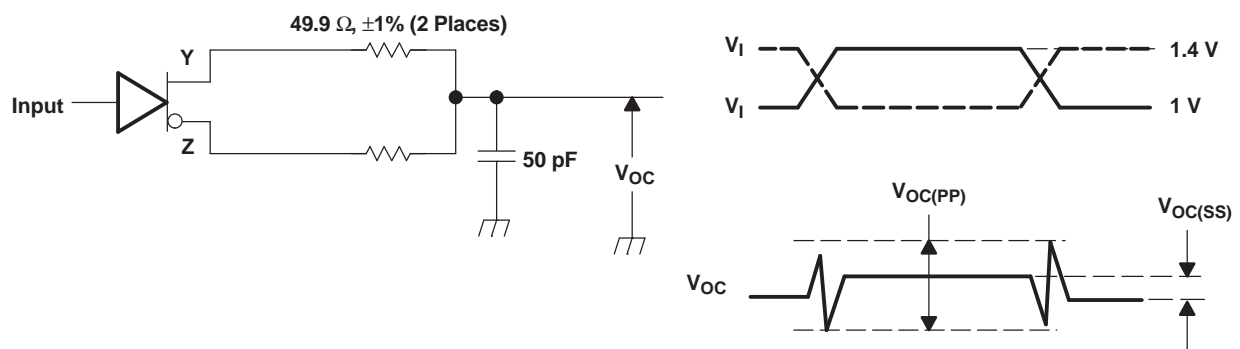

Figure 1. Driver Voltage and Current Definitions



- A. All input pulses are supplied by a generator having the following characteristics: t_r or $t_f \leq 1$ ns, pulse repetition rate (PRR) = 0.5 Mpps, pulse width = 500 ± 10 ns. C_L includes instrumentation and fixture capacitance within 0,06 mm of the D.U.T. The measurement of $V_{OC(PP)}$ is made on test equipment with a -3 dB bandwidth of at least 300 MHz.

Figure 2. Driver Test Circuit and Definitions for the Driver Common-Mode Output Voltage

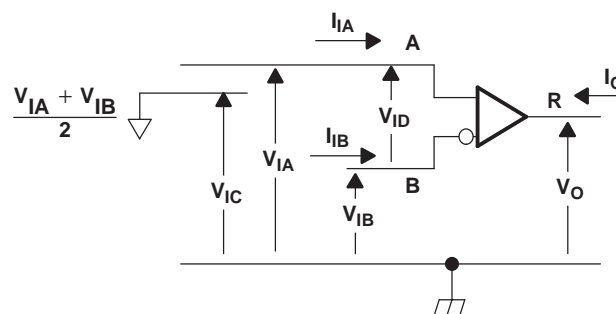
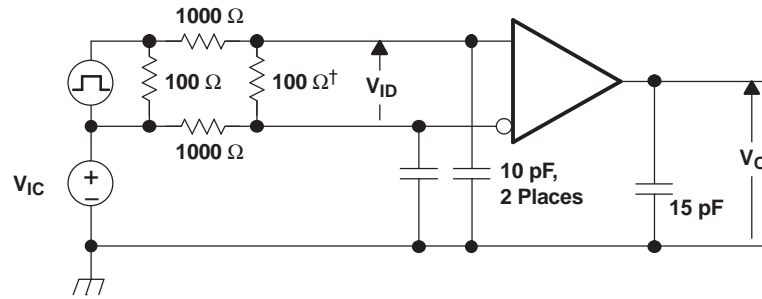

Figure 3. Receiver Voltage and Current Definitions

PARAMETER MEASUREMENT INFORMATION (continued)



† Remove for testing LVDT device.

NOTE: Input signal of 3 Mpps, duration of 167 ns, and transition time of < 1 ns.

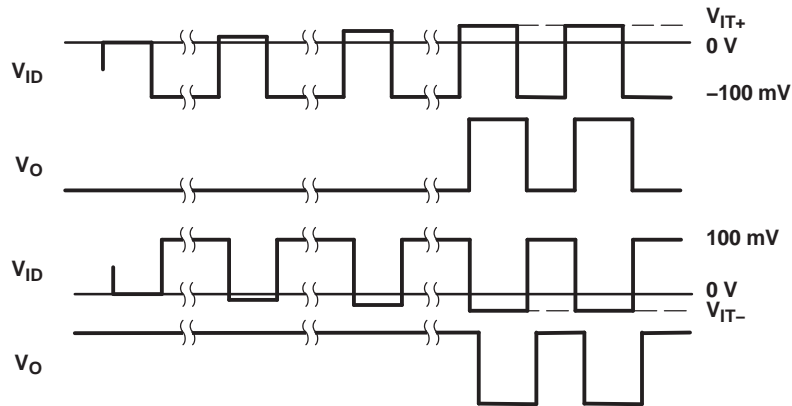

NOTE: Input signal of 3 Mpps, duration of 167 ns, and transition time of < 1 ns.

Figure 4. V_{IT+} and V_{IT-} Input Voltage Threshold Test Circuit and Definitions

PARAMETER MEASUREMENT INFORMATION (continued)

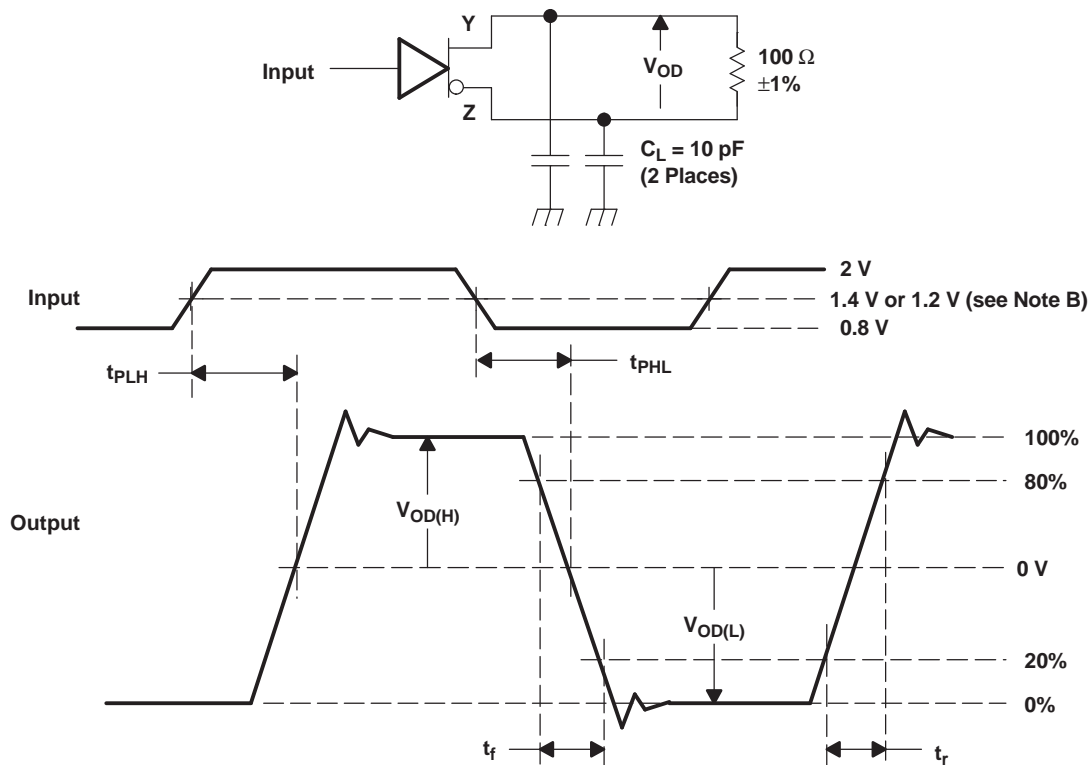

- A. All input pulses are supplied by a generator having the following characteristics: t_r or $t_f \leq 1 \text{ ns}$, pulse repetition rate (PRR) = 50 Mpps, pulse width = $10 \pm 0.2 \text{ ns}$. C_L includes instrumentation and fixture capacitance within 0,06 mm of the D.U.T.
- B. This point is 1.4 V with $V_{CC} = 3.3 \text{ V}$ or 1.2 V with $V_{CC} = 2.7 \text{ V}$.

Figure 5. Driver Test Circuit, Timing, and Voltage Definitions for the Differential Output Signal

PARAMETER MEASUREMENT INFORMATION (continued)

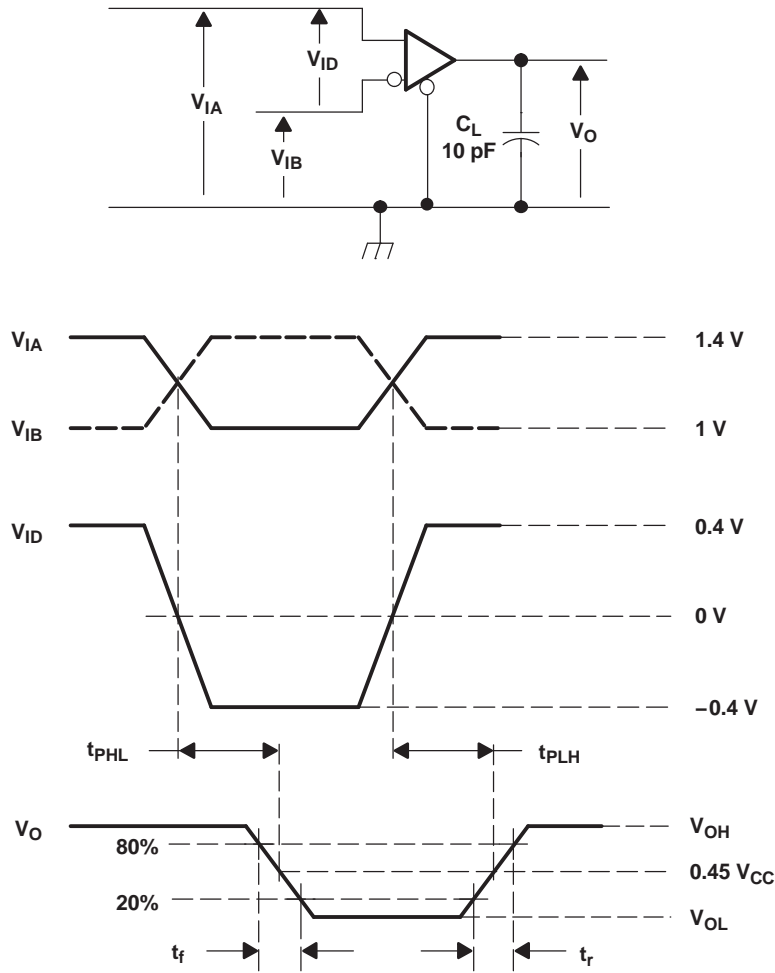

- A. All input pulses are supplied by a generator having the following characteristics: t_r or $t_f \leq 1$ ns, pulse repetition rate (PRR) = 50 Mpps, pulse width = 10 ± 0.2 ns. C_L includes instrumentation and fixture capacitance within 0,06 m of the D.U.T.

Figure 6. Receiver Timing Test Circuit and Waveforms

TYPICAL CHARACTERISTICS

DRIVER HIGH-TO-LOW LEVEL PROPAGATION DELAY TIMES vs FREE-AIR TEMPERATURE

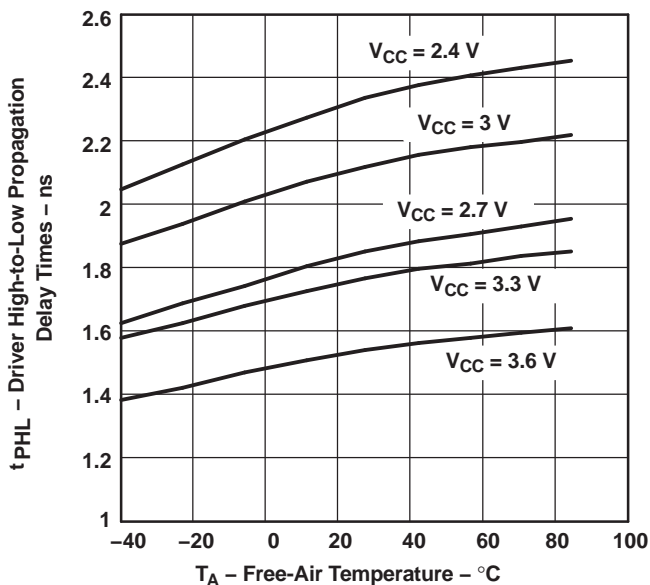

Figure 7.

DRIVER LOW-TO-HIGH LEVEL PROPAGATION DELAY TIMES vs FREE-AIR TEMPERATURE

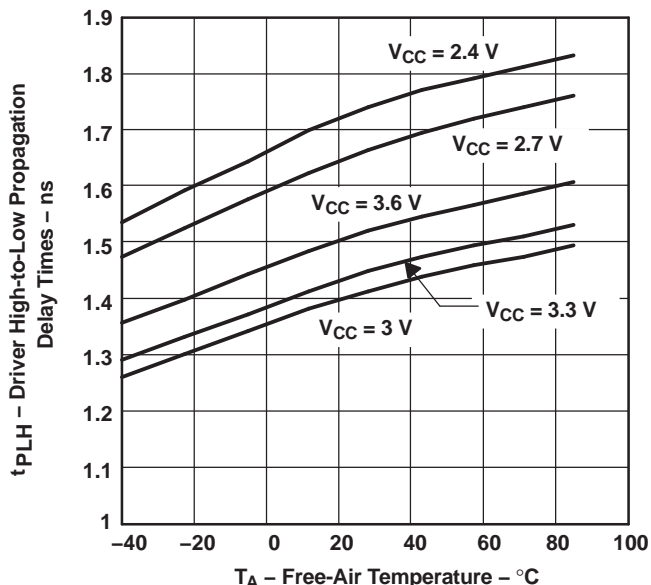

Figure 8.

RECEIVER HIGH-LEVEL OUTPUT VOLTAGE vs HIGH-LEVEL OUTPUT CURRENT

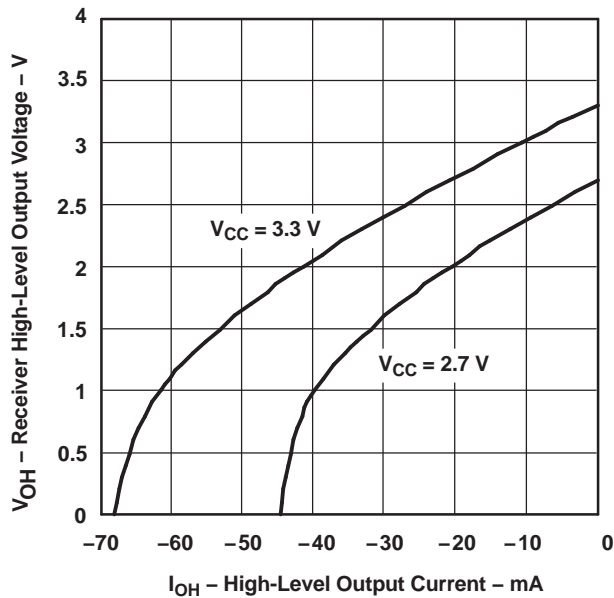

Figure 9.

RECEIVER LOW-LEVEL OUTPUT VOLTAGE vs LOW-LEVEL OUTPUT CURRENT

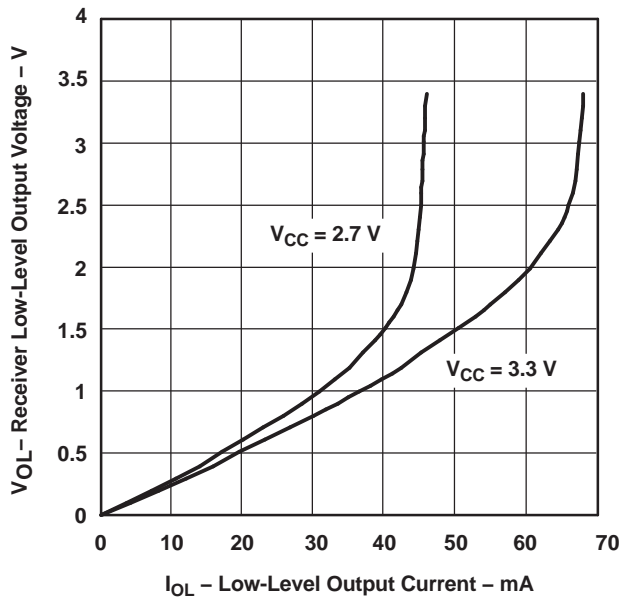

Figure 10.

TYPICAL CHARACTERISTICS (continued)

RECEIVER HIGH-TO-LOW LEVEL
 PROPAGATION DELAY TIMES
 vs
 FREE-AIR TEMPERATURE

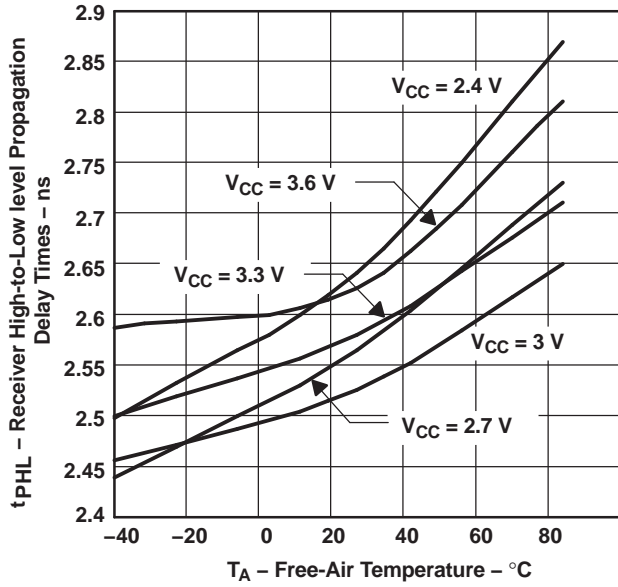

Figure 11.

RECEIVER LOW-TO-HIGH LEVEL
 PROPAGATION DELAY TIMES
 vs
 FREE-AIR TEMPERATURE

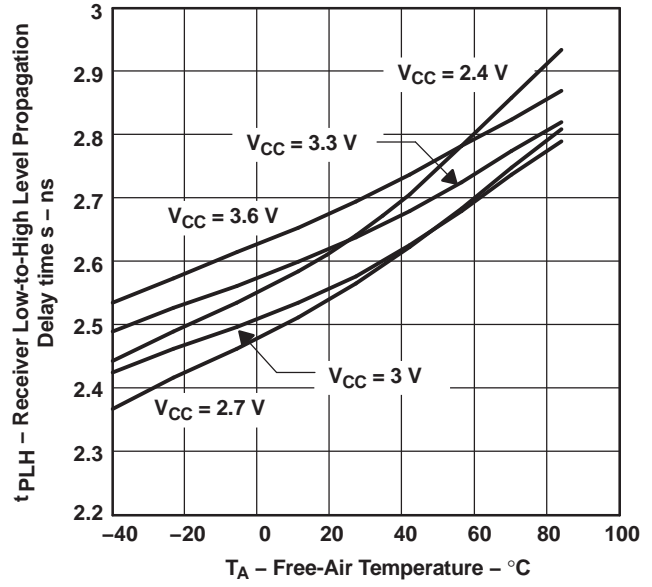

Figure 12.

RISE/FALL TIME
 vs
 CAPACITIVE LOAD

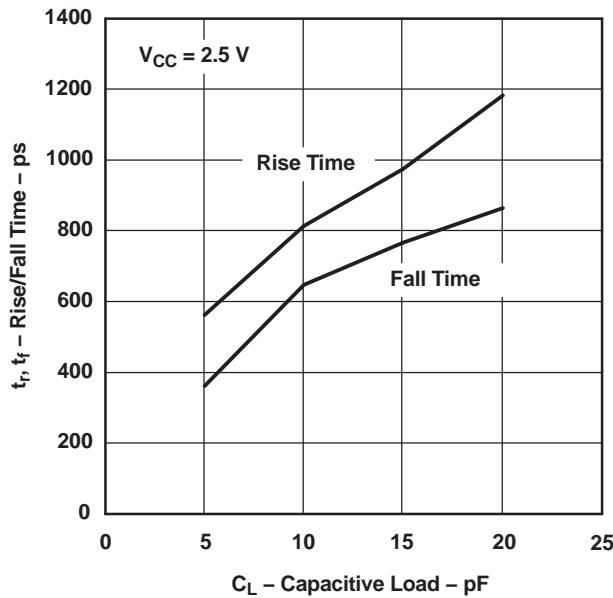

Figure 13.

RISE/FALL TIME
 vs
 CAPACITIVE LOAD

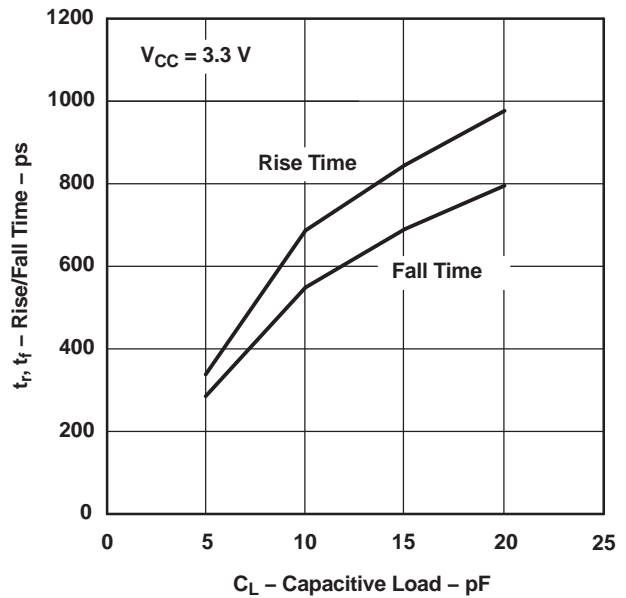

Figure 14.

APPLICATION INFORMATION

FAIL-SAFE

One of the most common problems with differential signaling applications is how the system responds when no differential voltage is present on the signal pair. The LVDS receiver is like most differential line receivers, in that its output logic state can be indeterminate when the differential input voltage is between -100 mV and 100 mV and within its recommended input common-mode voltage range. However, TI's LVDS receiver is different in how it handles the open-input circuit situation.

Open circuit means that there is little or no input current to the receiver from the data line itself. This could be when the driver is in a high-impedance state or the cable is disconnected. When this occurs, the LVDS receiver pulls each line of the signal pair to near V_{CC} through $300\text{-k}\Omega$ resistors as shown in Figure 15. The fail-safe feature uses an AND gate with input voltage thresholds at about 2.3 V to detect this condition and force the output to a high level regardless of the differential input voltage.

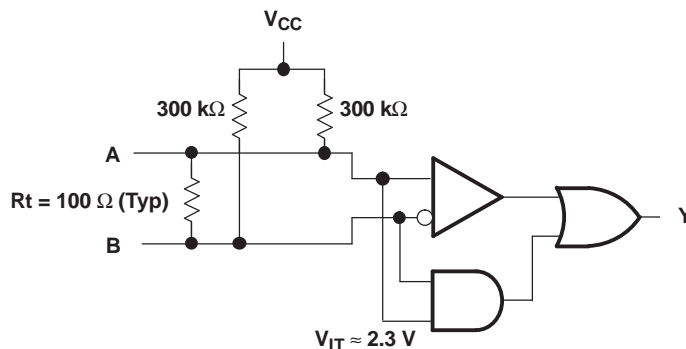

Figure 15. Open-Circuit Fail Safe of the LVDS Receiver

It is only under these conditions that the output of the receiver is valid with less than a 100 mV differential input voltage magnitude. The presence of the termination resistor, R_t , does not affect the fail-safe function as long as it is connected as shown in the figure. Other termination circuits may allow a dc current to ground that could defeat the pullup currents from the receiver and the fail-safe feature.

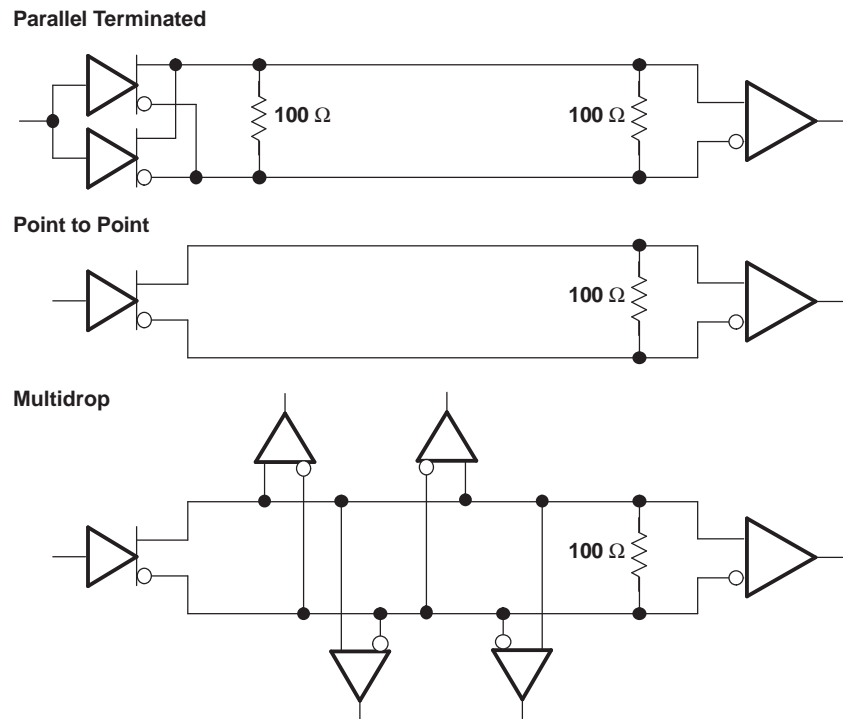

Figure 16. Typical Application Circuits

PACKAGING INFORMATION

Orderable Device	Status ⁽¹⁾	Package Type	Package Drawing	Pins	Package Qty	Eco Plan ⁽²⁾	Lead/ Ball Finish	MSL Peak Temp ⁽³⁾	Samples (Requires Login)
SN65LVDS1D	ACTIVE	SOIC	D	8	75	Green (RoHS & no Sb/Br)	CU NIPDAU	Level-1-260C-UNLIM	Add to cart
SN65LVDS1DBVR	ACTIVE	SOT-23	DBV	5	3000	Green (RoHS & no Sb/Br)	CU NIPDAU	Level-1-260C-UNLIM	Add to cart
SN65LVDS1DBVRG4	ACTIVE	SOT-23	DBV	5	3000	Green (RoHS & no Sb/Br)	CU NIPDAU	Level-1-260C-UNLIM	Add to cart
SN65LVDS1DBVT	ACTIVE	SOT-23	DBV	5	250	Green (RoHS & no Sb/Br)	CU NIPDAU	Level-1-260C-UNLIM	Add to cart
SN65LVDS1DBVTG4	ACTIVE	SOT-23	DBV	5	250	Green (RoHS & no Sb/Br)	CU NIPDAU	Level-1-260C-UNLIM	Add to cart
SN65LVDS1DG4	ACTIVE	SOIC	D	8	75	Green (RoHS & no Sb/Br)	CU NIPDAU	Level-1-260C-UNLIM	Add to cart
SN65LVDS1DR	ACTIVE	SOIC	D	8	2500	Green (RoHS & no Sb/Br)	CU NIPDAU	Level-1-260C-UNLIM	Add to cart
SN65LVDS1DRG4	ACTIVE	SOIC	D	8	2500	Green (RoHS & no Sb/Br)	CU NIPDAU	Level-1-260C-UNLIM	Add to cart
SN65LVDS2D	ACTIVE	SOIC	D	8	75	Green (RoHS & no Sb/Br)	CU NIPDAU	Level-1-260C-UNLIM	Add to cart
SN65LVDS2DBVR	ACTIVE	SOT-23	DBV	5	3000	Green (RoHS & no Sb/Br)	CU NIPDAU	Level-1-260C-UNLIM	Add to cart
SN65LVDS2DBVRG4	ACTIVE	SOT-23	DBV	5	3000	Green (RoHS & no Sb/Br)	CU NIPDAU	Level-1-260C-UNLIM	Add to cart
SN65LVDS2DBVT	ACTIVE	SOT-23	DBV	5	250	Green (RoHS & no Sb/Br)	CU NIPDAU	Level-1-260C-UNLIM	Add to cart
SN65LVDS2DBVTG4	ACTIVE	SOT-23	DBV	5	250	Green (RoHS & no Sb/Br)	CU NIPDAU	Level-1-260C-UNLIM	Add to cart
SN65LVDS2DG4	ACTIVE	SOIC	D	8	75	Green (RoHS & no Sb/Br)	CU NIPDAU	Level-1-260C-UNLIM	Add to cart
SN65LVDS2DR	ACTIVE	SOIC	D	8	2500	Green (RoHS & no Sb/Br)	CU NIPDAU	Level-1-260C-UNLIM	Add to cart
SN65LVDS2DRG4	ACTIVE	SOIC	D	8	2500	Green (RoHS & no Sb/Br)	CU NIPDAU	Level-1-260C-UNLIM	Add to cart
SN65LVDT2D	ACTIVE	SOIC	D	8	75	Green (RoHS & no Sb/Br)	CU NIPDAU	Level-1-260C-UNLIM	Add to cart

Orderable Device	Status ⁽¹⁾	Package Type	Package Drawing	Pins	Package Qty	Eco Plan ⁽²⁾	Lead/ Ball Finish	MSL Peak Temp ⁽³⁾	Samples (Requires Login)
SN65LVDT2DBVR	ACTIVE	SOT-23	DBV	5	3000	Green (RoHS & no Sb/Br)	CU NIPDAU	Level-1-260C-UNLIM	Add to cart
SN65LVDT2DBVRG4	ACTIVE	SOT-23	DBV	5	3000	Green (RoHS & no Sb/Br)	CU NIPDAU	Level-1-260C-UNLIM	Add to cart
SN65LVDT2DBVT	ACTIVE	SOT-23	DBV	5	250	Green (RoHS & no Sb/Br)	CU NIPDAU	Level-1-260C-UNLIM	Add to cart
SN65LVDT2DBVTG4	ACTIVE	SOT-23	DBV	5	250	Green (RoHS & no Sb/Br)	CU NIPDAU	Level-1-260C-UNLIM	Add to cart
SN65LVDT2DG4	ACTIVE	SOIC	D	8	75	Green (RoHS & no Sb/Br)	CU NIPDAU	Level-1-260C-UNLIM	Add to cart
SN65LVDT2DR	ACTIVE	SOIC	D	8	2500	Green (RoHS & no Sb/Br)	CU NIPDAU	Level-1-260C-UNLIM	Add to cart
SN65LVDT2DRG4	ACTIVE	SOIC	D	8	2500	Green (RoHS & no Sb/Br)	CU NIPDAU	Level-1-260C-UNLIM	Add to cart

⁽¹⁾ The marketing status values are defined as follows:

ACTIVE: Product device recommended for new designs.

LIFEBUY: TI has announced that the device will be discontinued, and a lifetime-buy period is in effect.

NRND: Not recommended for new designs. Device is in production to support existing customers, but TI does not recommend using this part in a new design.

PREVIEW: Device has been announced but is not in production. Samples may or may not be available.

OBSOLETE: TI has discontinued the production of the device.

⁽²⁾ Eco Plan - The planned eco-friendly classification: Pb-Free (RoHS), Pb-Free (RoHS Exempt), or Green (RoHS & no Sb/Br) - please check <http://www.ti.com/productcontent> for the latest availability information and additional product content details.

TBD: The Pb-Free/Green conversion plan has not been defined.

Pb-Free (RoHS): TI's terms "Lead-Free" or "Pb-Free" mean semiconductor products that are compatible with the current RoHS requirements for all 6 substances, including the requirement that lead not exceed 0.1% by weight in homogeneous materials. Where designed to be soldered at high temperatures, TI Pb-Free products are suitable for use in specified lead-free processes.

Pb-Free (RoHS Exempt): This component has a RoHS exemption for either 1) lead-based flip-chip solder bumps used between the die and package, or 2) lead-based die adhesive used between the die and leadframe. The component is otherwise considered Pb-Free (RoHS compatible) as defined above.

Green (RoHS & no Sb/Br): TI defines "Green" to mean Pb-Free (RoHS compatible), and free of Bromine (Br) and Antimony (Sb) based flame retardants (Br or Sb do not exceed 0.1% by weight in homogeneous material)

⁽³⁾ MSL, Peak Temp. -- The Moisture Sensitivity Level rating according to the JEDEC industry standard classifications, and peak solder temperature.

Important Information and Disclaimer: The information provided on this page represents TI's knowledge and belief as of the date that it is provided. TI bases its knowledge and belief on information provided by third parties, and makes no representation or warranty as to the accuracy of such information. Efforts are underway to better integrate information from third parties. TI has taken and continues to take reasonable steps to provide representative and accurate information but may not have conducted destructive testing or chemical analysis on incoming materials and chemicals. TI and TI suppliers consider certain information to be proprietary, and thus CAS numbers and other limited information may not be available for release.

In no event shall TI's liability arising out of such information exceed the total purchase price of the TI part(s) at issue in this document sold by TI to Customer on an annual basis.

TAPE AND REEL INFORMATION



QUADRANT ASSIGNMENTS FOR PIN 1 ORIENTATION IN TAPE

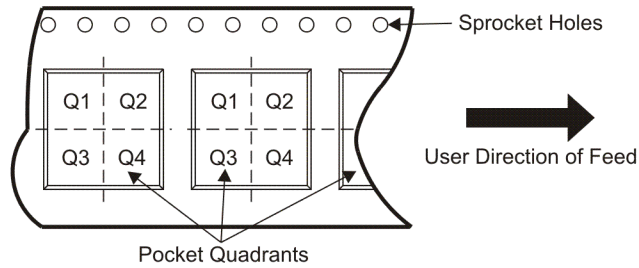

*All dimensions are nominal

Device	Package Type	Package Drawing	Pins	SPQ	Reel Diameter (mm)	Reel Width W1 (mm)	A0 (mm)	B0 (mm)	K0 (mm)	P1 (mm)	W (mm)	Pin1 Quadrant
SN65LVDS1DBVR	SOT-23	DBV	5	3000	180.0	9.0	3.15	3.2	1.4	4.0	8.0	Q3
SN65LVDS1DBVT	SOT-23	DBV	5	250	180.0	9.0	3.15	3.2	1.4	4.0	8.0	Q3
SN65LVDS1DR	SOIC	D	8	2500	330.0	12.4	6.4	5.2	2.1	8.0	12.0	Q1
SN65LVDS2DBVR	SOT-23	DBV	5	3000	180.0	9.0	3.15	3.2	1.4	4.0	8.0	Q3
SN65LVDS2DBVT	SOT-23	DBV	5	250	180.0	9.0	3.15	3.2	1.4	4.0	8.0	Q3
SN65LVDS2DR	SOIC	D	8	2500	330.0	12.4	6.4	5.2	2.1	8.0	12.0	Q1
SN65LVDT2DBVR	SOT-23	DBV	5	3000	180.0	9.0	3.15	3.2	1.4	4.0	8.0	Q3
SN65LVDT2DBVT	SOT-23	DBV	5	250	180.0	9.0	3.15	3.2	1.4	4.0	8.0	Q3
SN65LVDT2DR	SOIC	D	8	2500	330.0	12.4	6.4	5.2	2.1	8.0	12.0	Q1

TAPE AND REEL BOX DIMENSIONS

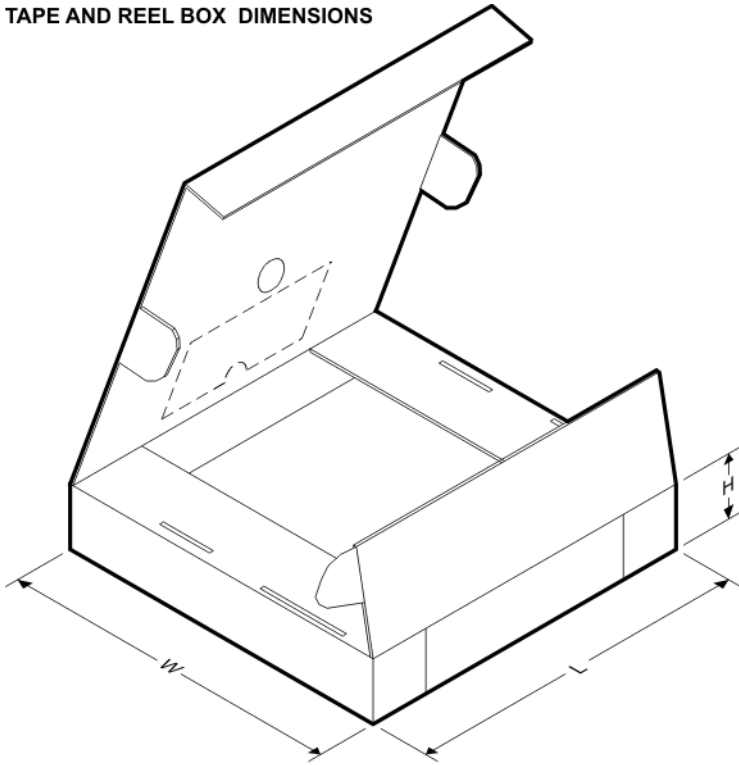

*All dimensions are nominal

Device	Package Type	Package Drawing	Pins	SPQ	Length (mm)	Width (mm)	Height (mm)
SN65LVDS1DBVR	SOT-23	DBV	5	3000	182.0	182.0	20.0
SN65LVDS1DBVT	SOT-23	DBV	5	250	182.0	182.0	20.0
SN65LVDS1DR	SOIC	D	8	2500	340.5	338.1	20.6
SN65LVDS2DBVR	SOT-23	DBV	5	3000	182.0	182.0	20.0
SN65LVDS2DBVT	SOT-23	DBV	5	250	182.0	182.0	20.0
SN65LVDS2DR	SOIC	D	8	2500	340.5	338.1	20.6
SN65LVDT2DBVR	SOT-23	DBV	5	3000	182.0	182.0	20.0
SN65LVDT2DBVT	SOT-23	DBV	5	250	182.0	182.0	20.0
SN65LVDT2DR	SOIC	D	8	2500	340.5	338.1	20.6

DBV (R-PDSO-G5)

PLASTIC SMALL-OUTLINE PACKAGE

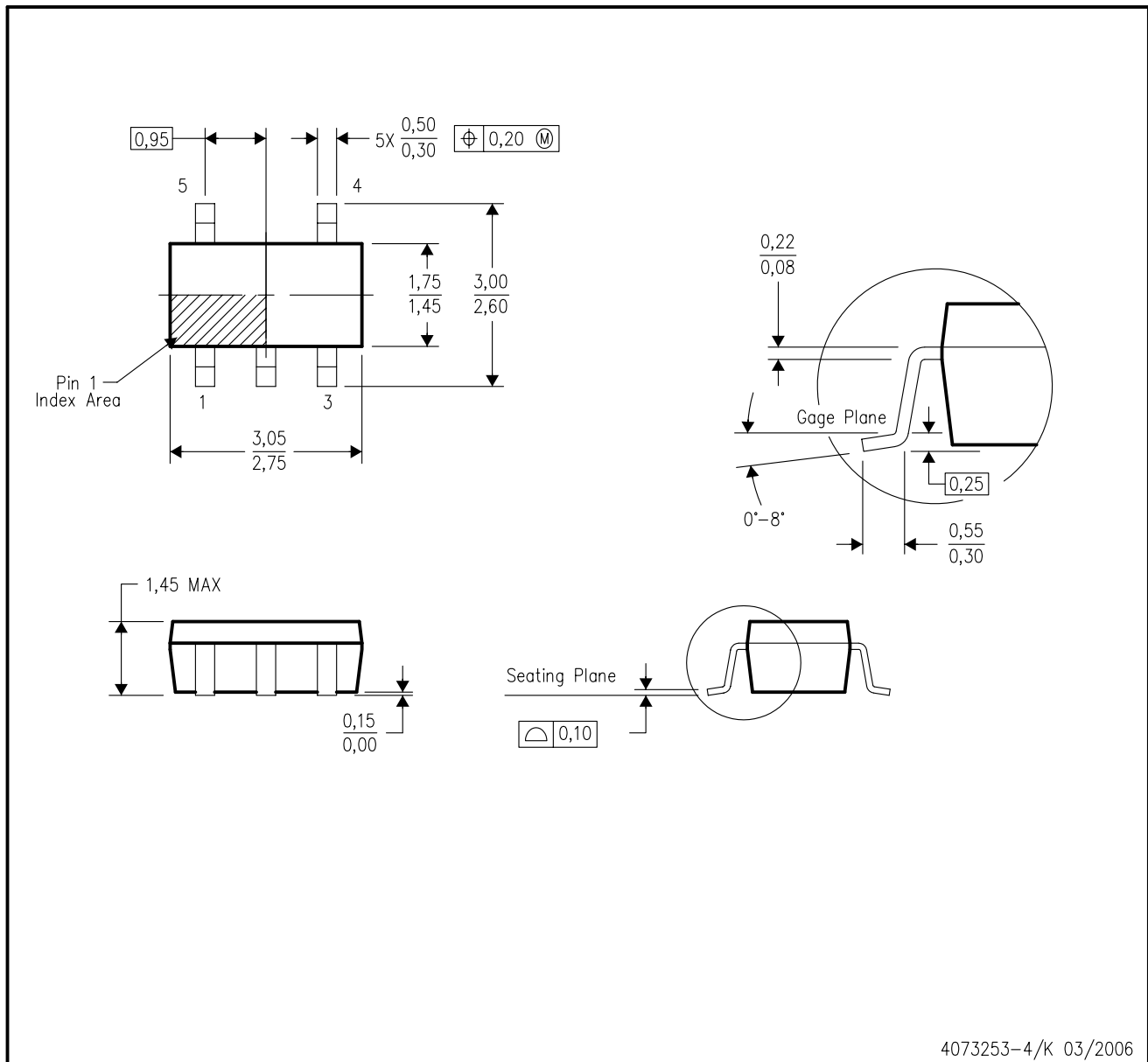

- NOTES:
- A. All linear dimensions are in millimeters.
 - B. This drawing is subject to change without notice.
 - C. Body dimensions do not include mold flash or protrusion. Mold flash and protrusion shall not exceed 0.15 per side.
 - D. Falls within JEDEC MO-178 Variation AA.

DBV (R-PDSO-G5)

PLASTIC SMALL OUTLINE

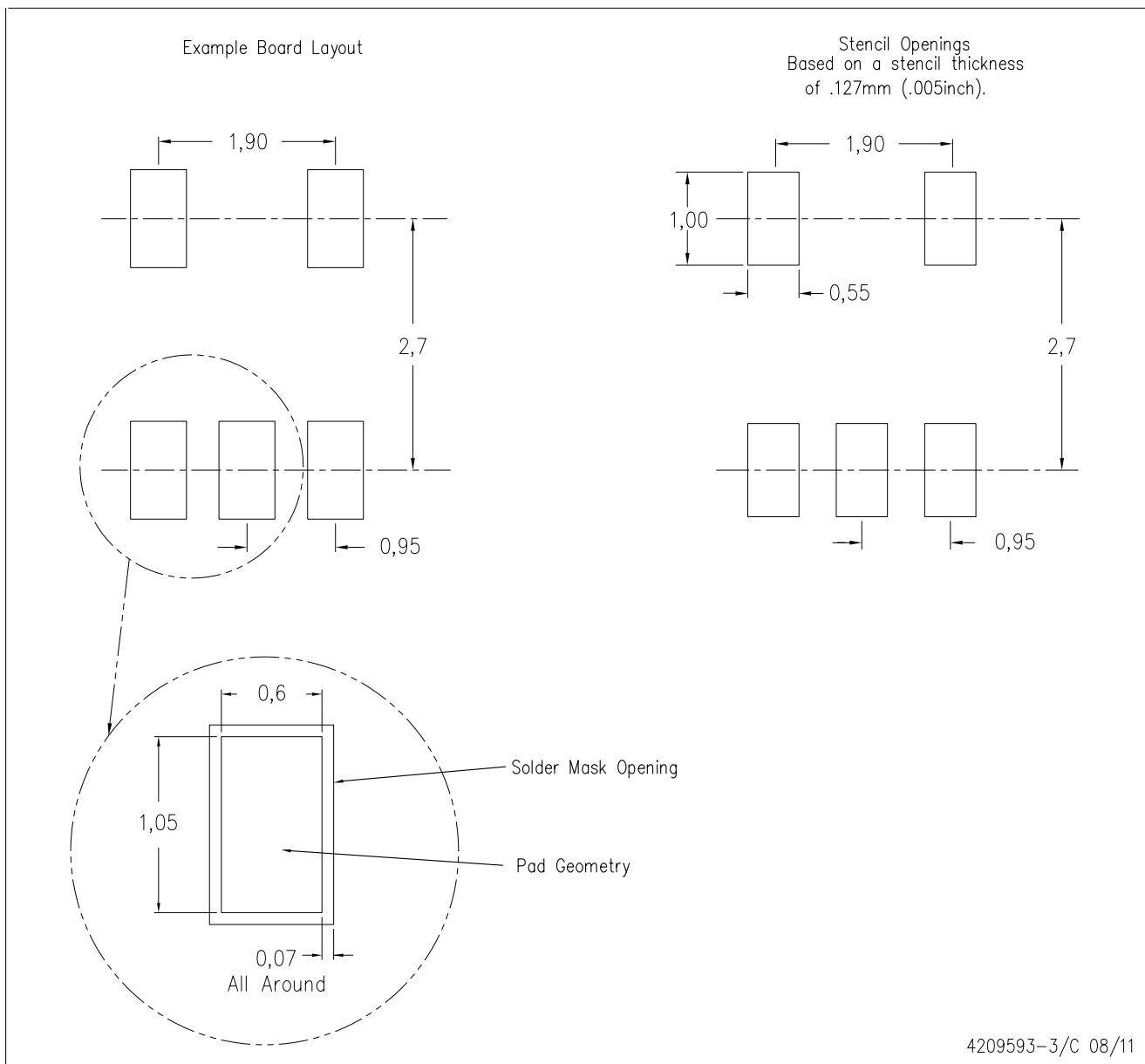

- NOTES:
- A. All linear dimensions are in millimeters.
 - B. This drawing is subject to change without notice.
 - C. Customers should place a note on the circuit board fabrication drawing not to alter the center solder mask defined pad.
 - D. Publication IPC-7351 is recommended for alternate designs.
 - E. Laser cutting apertures with trapezoidal walls and also rounding corners will offer better paste release. Customers should contact their board assembly site for stencil design recommendations. Example stencil design based on a 50% volumetric metal load solder paste. Refer to IPC-7525 for other stencil recommendations.

D (R-PDSO-G8)

PLASTIC SMALL OUTLINE

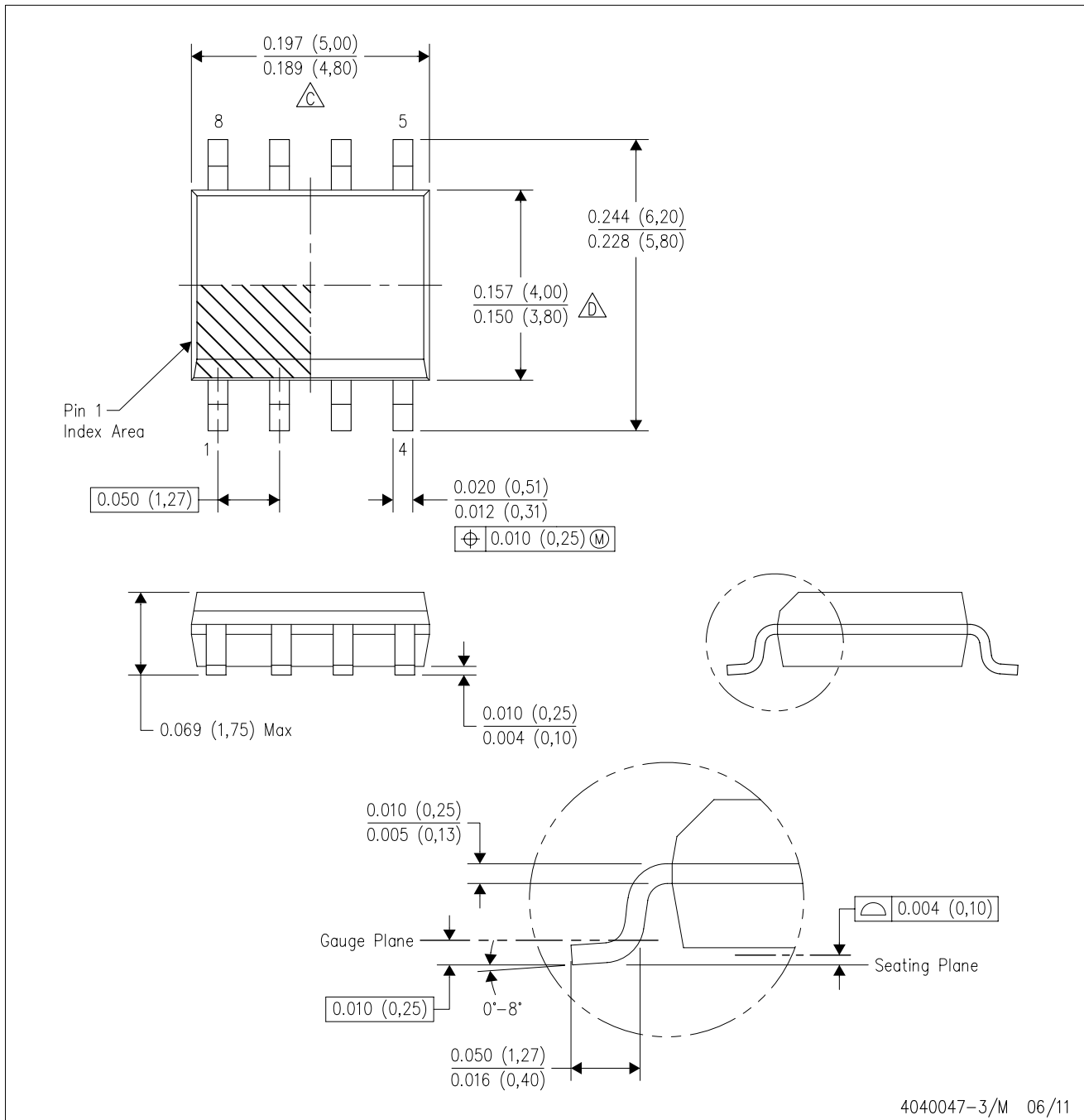

- NOTES:
- A. All linear dimensions are in inches (millimeters).
 - B. This drawing is subject to change without notice.
 - C. Body length does not include mold flash, protrusions, or gate burrs. Mold flash, protrusions, or gate burrs shall not exceed 0.006 (0,15) each side.
 - D. Body width does not include interlead flash. Interlead flash shall not exceed 0.017 (0,43) each side.
 - E. Reference JEDEC MS-012 variation AA.

D (R-PDSO-G8)

PLASTIC SMALL OUTLINE

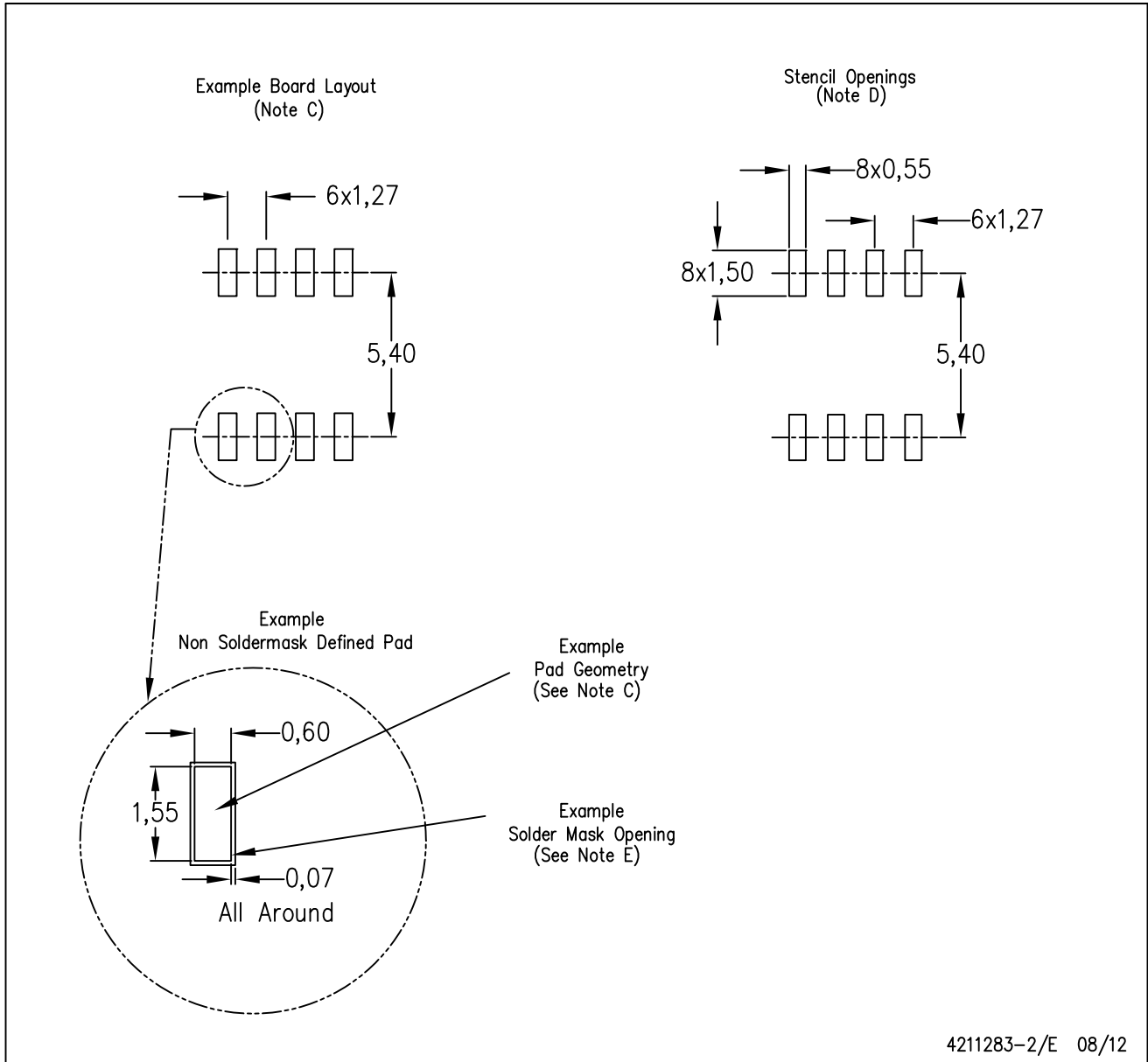

- NOTES:
- All linear dimensions are in millimeters.
 - This drawing is subject to change without notice.
 - Publication IPC-7351 is recommended for alternate designs.
 - Laser cutting apertures with trapezoidal walls and also rounding corners will offer better paste release. Customers should contact their board assembly site for stencil design recommendations. Refer to IPC-7525 for other stencil recommendations.
 - Customers should contact their board fabrication site for solder mask tolerances between and around signal pads.

IMPORTANT NOTICE

Texas Instruments Incorporated and its subsidiaries (TI) reserve the right to make corrections, enhancements, improvements and other changes to its semiconductor products and services per JESD46C and to discontinue any product or service per JESD48B. Buyers should obtain the latest relevant information before placing orders and should verify that such information is current and complete. All semiconductor products (also referred to herein as "components") are sold subject to TI's terms and conditions of sale supplied at the time of order acknowledgment.

TI warrants performance of its components to the specifications applicable at the time of sale, in accordance with the warranty in TI's terms and conditions of sale of semiconductor products. Testing and other quality control techniques are used to the extent TI deems necessary to support this warranty. Except where mandated by applicable law, testing of all parameters of each component is not necessarily performed.

TI assumes no liability for applications assistance or the design of Buyers' products. Buyers are responsible for their products and applications using TI components. To minimize the risks associated with Buyers' products and applications, Buyers should provide adequate design and operating safeguards.

TI does not warrant or represent that any license, either express or implied, is granted under any patent right, copyright, mask work right, or other intellectual property right relating to any combination, machine, or process in which TI components or services are used. Information published by TI regarding third-party products or services does not constitute a license to use such products or services or a warranty or endorsement thereof. Use of such information may require a license from a third party under the patents or other intellectual property of the third party, or a license from TI under the patents or other intellectual property of TI.

Reproduction of significant portions of TI information in TI data books or data sheets is permissible only if reproduction is without alteration and is accompanied by all associated warranties, conditions, limitations, and notices. TI is not responsible or liable for such altered documentation. Information of third parties may be subject to additional restrictions.

Resale of TI components or services with statements different from or beyond the parameters stated by TI for that component or service voids all express and any implied warranties for the associated TI component or service and is an unfair and deceptive business practice. TI is not responsible or liable for any such statements.

Buyer acknowledges and agrees that it is solely responsible for compliance with all legal, regulatory and safety-related requirements concerning its products, and any use of TI components in its applications, notwithstanding any applications-related information or support that may be provided by TI. Buyer represents and agrees that it has all the necessary expertise to create and implement safeguards which anticipate dangerous consequences of failures, monitor failures and their consequences, lessen the likelihood of failures that might cause harm and take appropriate remedial actions. Buyer will fully indemnify TI and its representatives against any damages arising out of the use of any TI components in safety-critical applications.

In some cases, TI components may be promoted specifically to facilitate safety-related applications. With such components, TI's goal is to help enable customers to design and create their own end-product solutions that meet applicable functional safety standards and requirements. Nonetheless, such components are subject to these terms.

No TI components are authorized for use in FDA Class III (or similar life-critical medical equipment) unless authorized officers of the parties have executed a special agreement specifically governing such use.

Only those TI components which TI has specifically designated as military grade or "enhanced plastic" are designed and intended for use in military/aerospace applications or environments. Buyer acknowledges and agrees that any military or aerospace use of TI components which have **not** been so designated is solely at the Buyer's risk, and that Buyer is solely responsible for compliance with all legal and regulatory requirements in connection with such use.

TI has specifically designated certain components which meet ISO/TS16949 requirements, mainly for automotive use. Components which have not been so designated are neither designed nor intended for automotive use; and TI will not be responsible for any failure of such components to meet such requirements.

Products

Audio	www.ti.com/audio
Amplifiers	amplifier.ti.com
Data Converters	dataconverter.ti.com
DLP® Products	www.dlp.com
DSP	dsp.ti.com
Clocks and Timers	www.ti.com/clocks
Interface	interface.ti.com
Logic	logic.ti.com
Power Mgmt	power.ti.com
Microcontrollers	microcontroller.ti.com
RFID	www.ti-rfid.com
OMAP Mobile Processors	www.ti.com/omap
Wireless Connectivity	www.ti.com/wirelessconnectivity

Applications

Automotive and Transportation	www.ti.com/automotive
Communications and Telecom	www.ti.com/communications
Computers and Peripherals	www.ti.com/computers
Consumer Electronics	www.ti.com/consumer-apps
Energy and Lighting	www.ti.com/energy
Industrial	www.ti.com/industrial
Medical	www.ti.com/medical
Security	www.ti.com/security
Space, Avionics and Defense	www.ti.com/space-avionics-defense
Video and Imaging	www.ti.com/video

TI E2E Community e2e.ti.com