

SN65LVDS1, SN65LVDS2, SN65LVDT2 HIGH-SPEED DIFFERENTIAL LINE DRIVER/RECEIVERS

SLLS373F – JULY 1999 – REVISED JULY 2002

- Meets or Exceeds the ANSI TIA/EIA-644A Standard
- Designed for Signaling Rates† up to:
 - 630 Mbps Drivers
 - 400 Mbps Receivers
- Operates From a 2.4-V to 3.6-V Supply
- Available in SOT-23 and SOIC Packages
- Bus-Terminal ESD Exceeds 15 kV
- Low-Voltage Differential Signaling With Typical Output Voltages of 350 mV Into a 100-Ω Load
- Propagation Delay Times
 - 1.7 ns Typical Driver
 - 2.5 ns Typical Receiver
- Power Dissipation at 200 MHz
 - 25 mW Typical Driver
 - 60 mW Typical Receiver
- LVDT Receiver Includes Line Termination
- Low Voltage TTL (LVTTTL) Level Driver Input Is 5-V Tolerant
- Driver Is Output High Impedance With $V_{CC} < 1.5 V$
- Receiver Output and Inputs Are High Impedance With $V_{CC} < 1.5 V$
- Receiver Open-Circuit Fail Safe
- Differential Input Voltage Threshold Less Than 100 mV

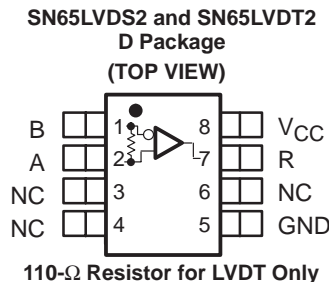
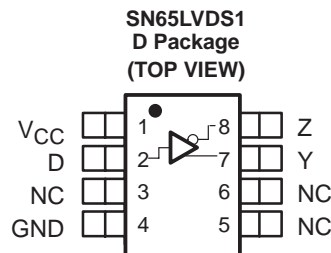
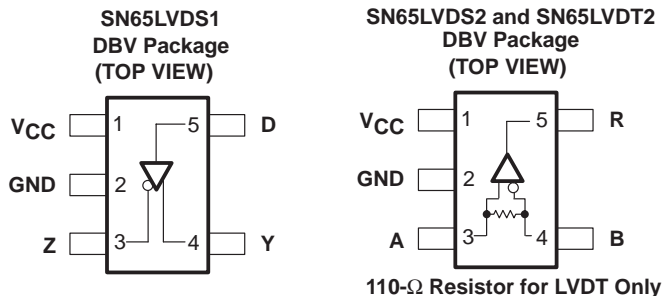

AVAILABLE OPTIONS

PART NUMBER	INTEGRATED TERMINATION	PACKAGE	PACKAGE MARKING
SN65LVDS1DBV		SOT23-5	SAAI
SN65LVDS1D		SOIC-8	LVDS1
SN65LVDS2DBV		SOT23-5	SABI
SN65LVDS2D		SOIC-8	LVDS2
SN65LVDT2DBV	√	SOT23-5	SACI
SN65LVDT2D	√	SOIC-8	LVDT2

description

The SN65LVDS1, SN65LVDS2, and SN65LVDT2 are single, low-voltage, differential line drivers and receivers in the small-outline transistor package. The outputs comply with the TIA/EIA-644A standard and provide a minimum differential output voltage magnitude of 247 mV into a 100-Ω load at signaling rates up to 630 Mbps for drivers and 400 Mbps for receivers.

When the SN65LVDS1 is used with an LVDS receiver (such as the SN65LVDT2) in a point-to-point connection, data or clocking signals can be transmitted over printed-circuit-board traces or cables at very high rates with very low electromagnetic emissions and power consumption. The packaging, low power, low EMI, high ESD tolerance, and wide supply voltage range make the device ideal for battery-powered applications.

The SN65LVDS1, SN65LVDS2, and SN65LVDT2 are characterized for operation from -40°C to 85°C.



Please be aware that an important notice concerning availability, standard warranty, and use in critical applications of Texas Instruments semiconductor products and disclaimers thereto appears at the end of this data sheet.

†The signaling rate of a line is the number of voltage transitions that are made per second expressed in the units bps (bits per second)

PRODUCTION DATA information is current as of publication date. Products conform to specifications per the terms of Texas Instruments standard warranty. Production processing does not necessarily include testing of all parameters.

**TEXAS
INSTRUMENTS**
TI.COM

Copyright © 2002, Texas Instruments Incorporated

SN65LVDS1, SN65LVDS2, SN65LVDT2 HIGH-SPEED DIFFERENTIAL LINE DRIVER/RECEIVERS

SLLS373F – JULY 1999 – REVISED JULY 2002

Function Tables

DRIVER			RECEIVER	
INPUT	OUTPUTS		INPUTS	OUTPUT
D	Y	Z	$V_{ID} = V_A - V_B$	R
H	H	L	$V_{ID} \geq 100 \text{ mV}$	H
L	L	H	$-100 \text{ mV} < V_{ID} < 100 \text{ mV}$?
Open	L	H	$V_{ID} \leq -100 \text{ mV}$	L
			Open	H

H = high level, L = low level, ? = indeterminate

driver equivalent input and output schematic diagrams

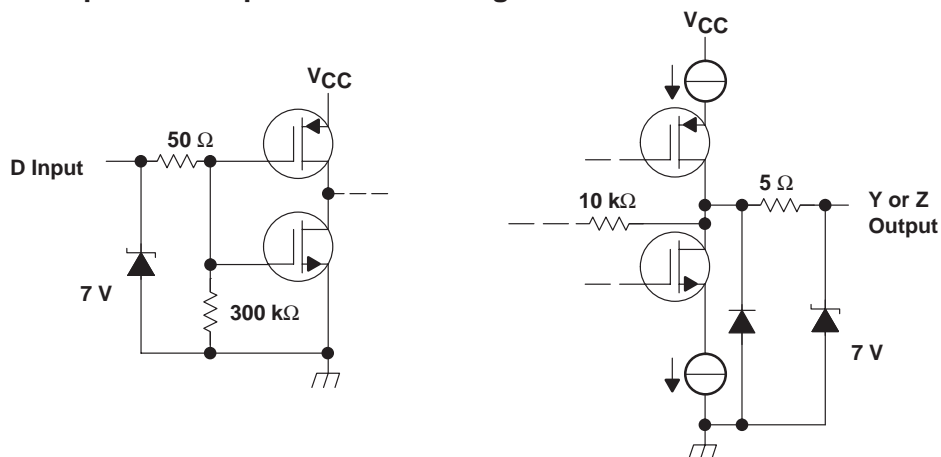

receiver equivalent input and output schematic diagrams

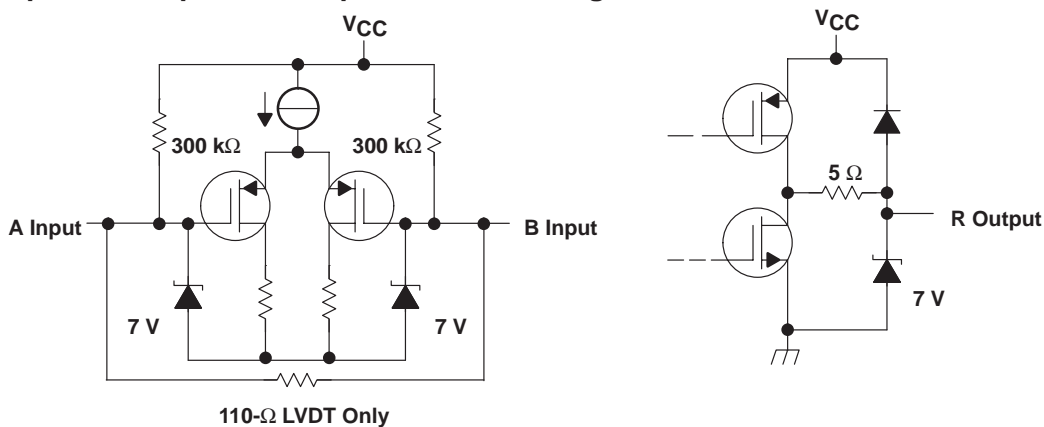

SN65LVDS1, SN65LVDS2, SN65LVDT2 HIGH-SPEED DIFFERENTIAL LINE DRIVER/RECEIVERS

SLLS373F – JULY 1999 – REVISED JULY 2002

absolute maximum ratings over operating free-air temperature (unless otherwise noted)[†]

Supply voltage range, V_{CC} (see Note 1)	–0.5 V to 4 V
Input voltage range: (D)	–0.5 V to $V_{CC} + 2$ V
(A, B, Y, or Z)	–0.5 V to $V_{CC} + 0.5$ V
$ V_{ID} $ (LVDT2)	1 V
Electrostatic discharge: A, B, Y, Z, and GND (see Note 2)	Class 3, A:15 kV, B:600 V
Continuous total power dissipation	See Dissipation Rating Table
Storage temperature range	–65°C to 150°C
Lead temperature 1,6 mm (1/16 inch) from case for 10 seconds	250°C

[†] Stresses beyond those listed under “absolute maximum ratings” may cause permanent damage to the device. These are stress ratings only, and functional operation of the device at these or any other conditions beyond those indicated under “recommended operating conditions” is not implied. Exposure to absolute-maximum-rated conditions for extended periods may affect device reliability.

- NOTES: 1. All voltage values, except differential I/O bus voltages are with respect to network ground terminal.
2. Tested in accordance with JEDEC Standard 22, Test Method A114–A.

DISSIPATION RATING TABLE

PACKAGE	$T_A \leq 25^\circ\text{C}$ POWER RATING	DERATING FACTOR ABOVE $T_A = 25^\circ\text{C}$ [‡]	$T_A = 85^\circ\text{C}$ POWER RATING
D	725 mW	5.8 mW/°C	402 mW
DBV	385 mW	3.1 mW/°C	200 mW

[‡] This is the inverse of the junction-to-ambient thermal resistance when board-mounted (low-K) and with no air flow.

recommended operating conditions

	MIN	NOM	MAX	UNIT
Supply voltage, V_{CC}	2.4	3.3	3.6	V
High-level input voltage, V_{IH}	2		5	V
Low-level input voltage, V_{IL}	0		0.8	V
Operating free-air temperature, T_A	–40		85	°C
Magnitude of differential input voltage, $ V_{ID} $	0.1		0.6	V
Input voltage (any combination of input or common-mode voltage)	0		$V_{CC} - 0.8$	V

SN65LVDS1, SN65LVDS2, SN65LVDT2 HIGH-SPEED DIFFERENTIAL LINE DRIVER/RECEIVERS

SLLS373F – JULY 1999 – REVISED JULY 2002

driver electrical characteristics over recommended operating conditions (unless otherwise noted)

PARAMETER		TEST CONDITIONS	MIN [‡]	TYP [†]	MAX	UNIT
V _{OD}	Differential output voltage magnitude	R _L = 100 Ω, 2.4 ≤ V _{CC} < 3 V	200	350	454	mV
		R _L = 100 Ω, 3 ≤ V _{CC} < 3.6 V	247	350	454	
Δ V _{OD}	Change in differential output voltage magnitude between logic states	See Figure 2	-50		50	
V _{OC(SS)}	Steady-state common-mode output voltage	See Figure 2	1.125		1.375	V
ΔV _{OC(SS)}	Change in steady-state common-mode output voltage between logic states		-50		50	mV
V _{OC(PP)}	Peak-to-peak common-mode output voltage			25		100
I _{CC}	Supply current	V _I = 0 V or V _{CC} , No load		2	4	mA
		V _I = 0 V or V _{CC} , R _L = 100 Ω		5.5	8	
I _{IH}	High-level input current	V _{IH} = 5 V		2	20	μA
I _{IL}	Low-level input current	V _{IL} = 0.8 V		2	10	μA
I _{OS}	Short-circuit output current	V _{OY} or V _{OZ} = 0 V		3	10	mA
		V _{OD} = 0 V			10	
I _{O(OFF)}	Power-off output current	V _{CC} = 0 V, V _O = 3.6 V	-1		1	μA
C _i	Input capacitance	V _I = 0.4 Sin (4E6πt) + 0.5 V		3		pF

[†] All typical values are at 25°C and with a 3.3-V supply.

[‡] The algebraic convention, in which the least positive (most negative) limit is designated as a minimum, is used in this data sheet.

driver switching characteristics over recommended operating conditions (unless otherwise noted)

PARAMETER		TEST CONDITIONS	MIN	TYP [†]	MAX	UNIT
t _{PLH}	Propagation delay time, low-to-high-level output	R _L = 100 Ω, C _L = 10 pF, See Figure 5		1.5	3.1	ns
t _{PHL}	Propagation delay time, high-to-low-level output			1.8	3.1	ns
t _r	Differential output signal rise time			0.6	1	ns
t _f	Differential output signal fall time			0.7	1	ns
t _{sk(p)}	Pulse skew (t _{PHL} - t _{PLH}) [‡]			0.3		ns

[†] All typical values are at 25°C and with a 3.3-V supply.

[‡] t_{sk(p)} is the magnitude of the time difference between the high-to-low and low-to-high propagation delay times at an output.

SN65LVDS1, SN65LVDS2, SN65LVDT2 HIGH-SPEED DIFFERENTIAL LINE DRIVER/RECEIVERS

SLLS373F – JULY 1999 – REVISED JULY 2002

receiver electrical characteristics over recommended operating conditions (unless otherwise noted)

PARAMETER		TEST CONDITIONS	MIN [‡]	TYP [†]	MAX	UNIT	
V _{ITH+}	Positive-going differential input voltage threshold	See Figure 3			100	mV	
V _{ITH-}	Negative-going differential input voltage threshold				-100		
V _{OH}	High-level output voltage	I _{OH} = -8 mA, V _{CC} = 2.4 V		1.9		V	
		I _{OH} = -8 mA, V _{CC} = 3 V		2.4			
V _{OL}	Low-level output voltage	I _{OL} = 8 mA		0.25	0.4	V	
I _{CC}	Supply current	No load, Steady state		4	7	mA	
I _I	Input current (A or B inputs)	LVDS2	V _I = 0 V, other input = 1.2 V	-20		-2	μA
			V _I = 2.2 V, other input = 1.2 V, V _{CC} = 3.0 V		-3	-1.2	
		LVDT2	V _I = 0 V, other input open	-40		-4	
			V _I = 2.2 V, other input open, V _{CC} = 3.0 V		-6	-2.4	
I _{ID}	Differential input current (I _{IA} - I _{IB})	LVDS2	V _{IA} = 2.4 V V _{IB} = 2.3 V	-2		2	μA
I _{I(OFF)}	Power-off input current (A or B inputs)	LVDS2	V _{CC} = 0 V, V _{IA} = V _{IB} = 2.4 V			20	μA
		LVDT2	V _{CC} = 0 V, V _{IA} = V _{IB} = 2.4 V			40	
R _T	Differential input resistance	LVDT2	V _{IA} = 2.4 V V _{IB} = 2.2 V	90	111	132	Ω

[†] All typical values are at 25°C and with a 2.7-V supply.

[‡] The algebraic convention, in which the least positive (most negative) limit is designated as a minimum, is used in this data sheet.

receiver switching characteristics over recommended operating conditions (unless otherwise noted)

PARAMETER		TEST CONDITIONS	MIN	TYP [†]	MAX	UNIT	
t _{PLH}	Propagation delay time, low-to-high-level output	C _L = 10 pF, See Figure 6		1.4	2.6	3.6	ns
t _{PHL}	Propagation delay time, high-to-low-level output			1.4	2.5	3.6	ns
t _{sk(p)}	Pulse skew (t _{pHL} - t _{pLH}) [‡]				0.1	0.6	ns
t _r	Output signal rise time				0.8	1.4	ns
t _f	Output signal fall time				0.8	1.4	ns

[†] All typical values are at 25°C and with a 2.7-V supply.

[‡] t_{sk(p)} is the magnitude of the time difference between the high-to-low and low-to-high propagation delay times at an output.

SN65LVDS1, SN65LVDS2, SN65LVDT2 HIGH-SPEED DIFFERENTIAL LINE DRIVER/RECEIVERS

SLLS373F – JULY 1999 – REVISED JULY 2002

PARAMETER MEASUREMENT INFORMATION

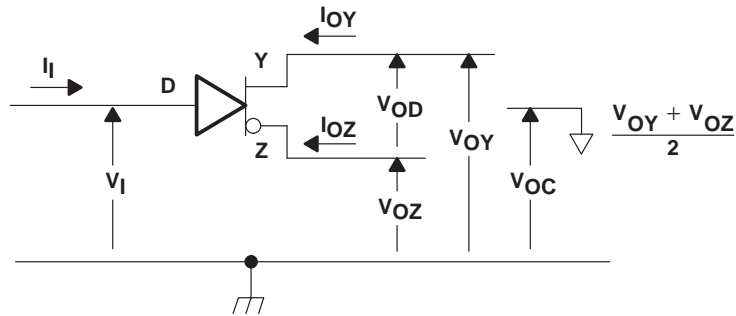
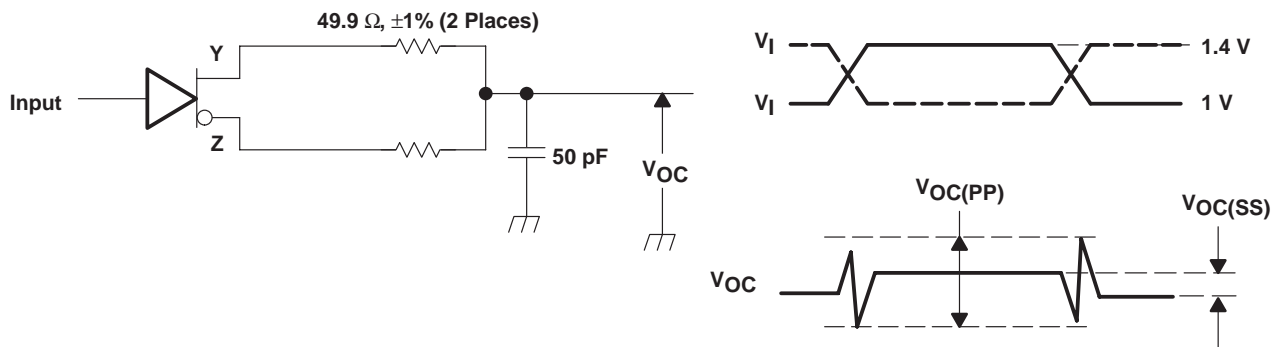

Figure 1. Driver Voltage and Current Definitions



NOTE A: All input pulses are supplied by a generator having the following characteristics: t_r or $t_f \leq 1$ ns, pulse repetition rate (PRR) = 0.5 Mpps, pulse width = 500 ± 10 ns. C_L includes instrumentation and fixture capacitance within 0,06 mm of the D.U.T. The measurement of $V_{OC(PP)}$ is made on test equipment with a -3 dB bandwidth of at least 300 MHz.

Figure 2. Driver Test Circuit and Definitions for the Driver Common-Mode Output Voltage

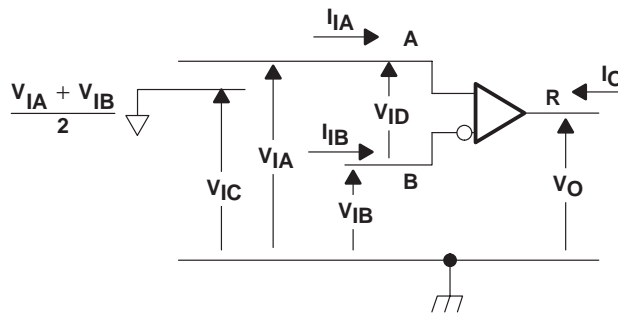
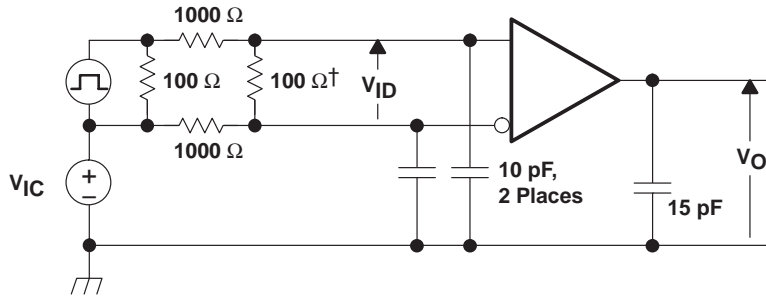

Figure 3. Receiver Voltage and Current Definitions

PARAMETER MEASUREMENT INFORMATION



† Remove for testing LVDT device.

NOTE: Input signal of 3 Mpps, duration of 167 ns, and transition time of < 1 ns.

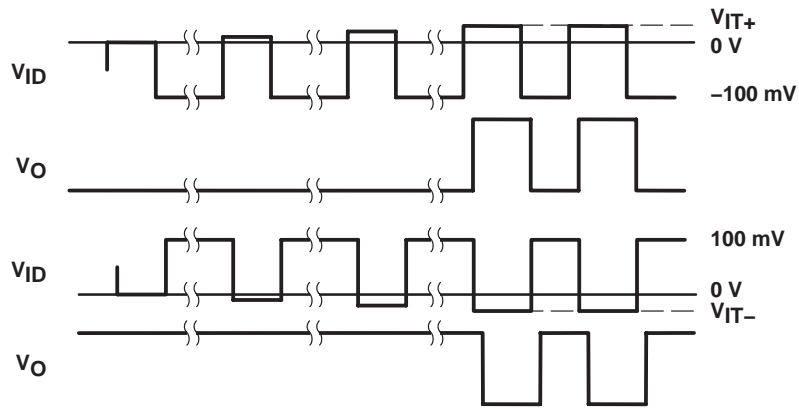

NOTE: Input signal of 3 Mpps, duration of 167 ns, and transition time of <1 ns.

Figure 4. V_{IT+} and V_{IT-} Input Voltage Threshold Test Circuit and Definitions

SN65LVDS1, SN65LVDS2, SN65LVDT2 HIGH-SPEED DIFFERENTIAL LINE DRIVER/RECEIVERS

SLLS373F – JULY 1999 – REVISED JULY 2002

PARAMETER MEASUREMENT INFORMATION

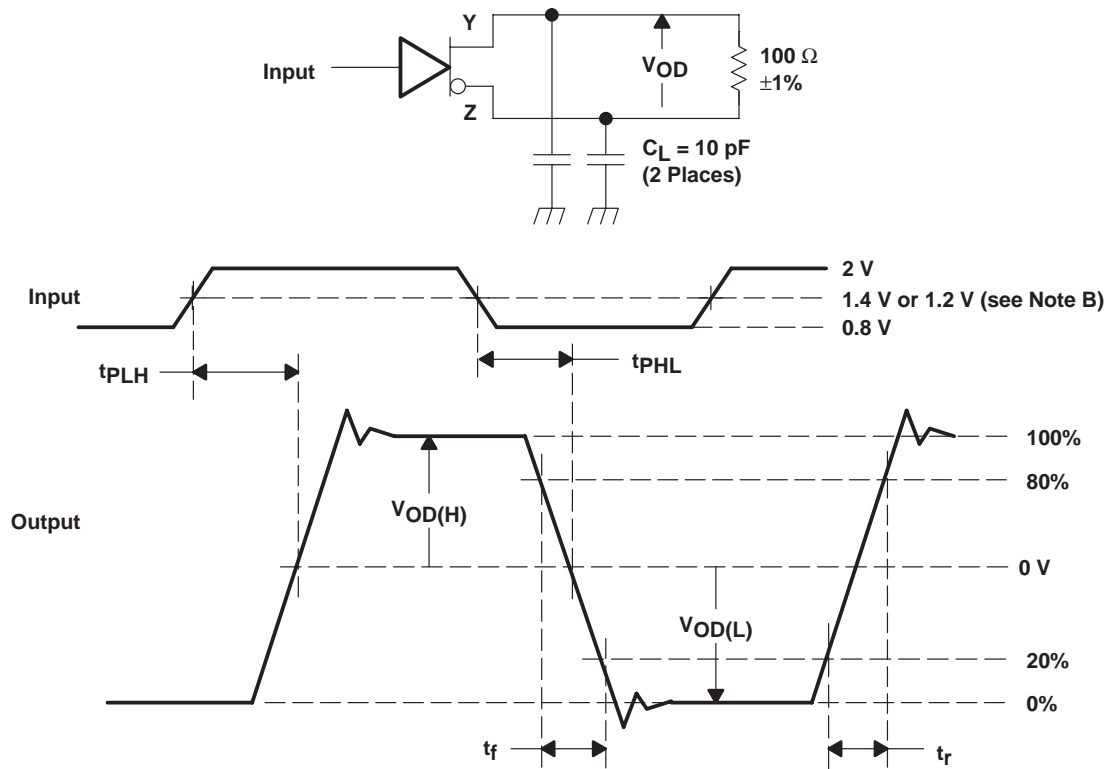

NOTES: A. All input pulses are supplied by a generator having the following characteristics: t_r or $t_f \leq 1\ \text{ns}$, pulse repetition rate (PRR) = 50 Mpps, pulse width = $10 \pm 0.2\ \text{ns}$. C_L includes instrumentation and fixture capacitance within 0,06 mm of the D.U.T.
B. This point is 1.4 V with $V_{CC} = 3.3\ \text{V}$ or 1.2 V with $V_{CC} = 2.7\ \text{V}$

Figure 5. Driver Test Circuit, Timing, and Voltage Definitions for the Differential Output Signal

PARAMETER MEASUREMENT INFORMATION

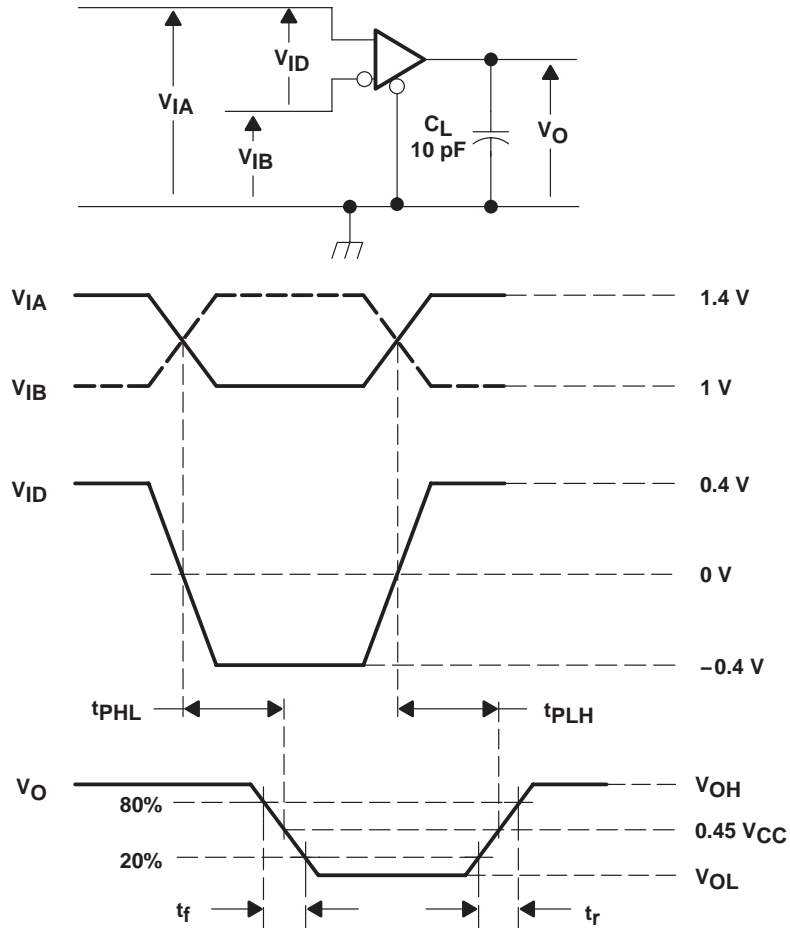

NOTE A: All input pulses are supplied by a generator having the following characteristics: t_r or $t_f \leq 1$ ns, pulse repetition rate (PRR) = 50 Mpps, pulse width = 10 ± 0.2 ns. C_L includes instrumentation and fixture capacitance within 0,06 m of the D.U.T.

Figure 6. Receiver Timing Test Circuit and Waveforms

SN65LVDS1, SN65LVDS2, SN65LVDT2 HIGH-SPEED DIFFERENTIAL LINE DRIVER/RECEIVERS

SLLS373F – JULY 1999 – REVISED JULY 2002

TYPICAL CHARACTERISTICS

DRIVER HIGH-TO-LOW LEVEL
PROPAGATION DELAY TIMES
vs
FREE-AIR TEMPERATURE

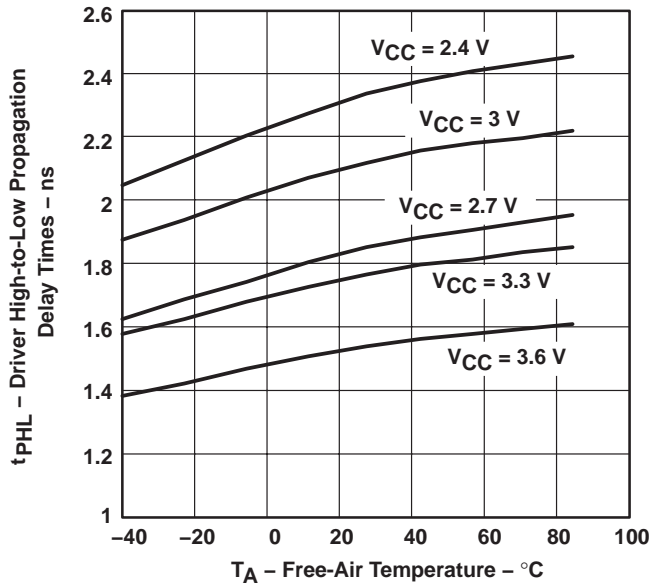

Figure 7

DRIVER LOW-TO-HIGH LEVEL
PROPAGATION DELAY TIME
vs
FREE-AIR TEMPERATURE

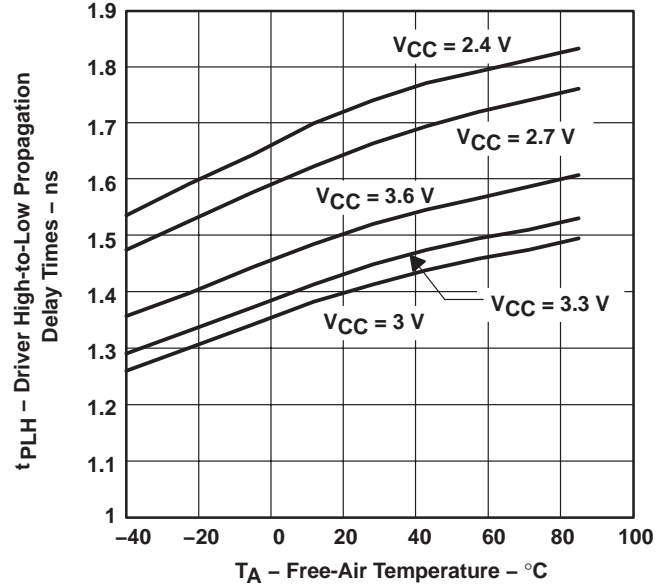

Figure 8

RECEIVER HIGH-LEVEL OUTPUT VOLTAGE
vs
HIGH-LEVEL OUTPUT CURRENT

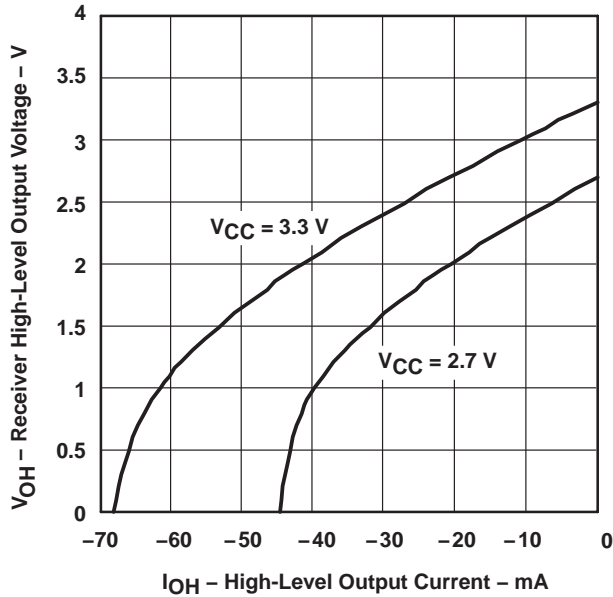

Figure 9

RECEIVER LOW-LEVEL OUTPUT VOLTAGE
vs
LOW-LEVEL OUTPUT CURRENT

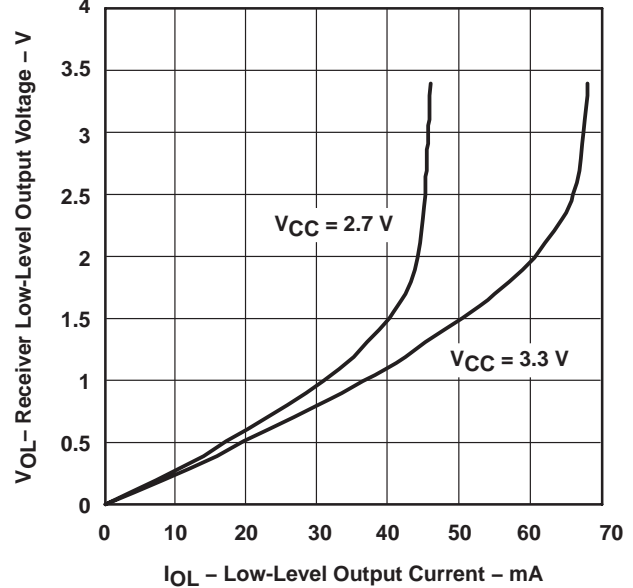

Figure 10

TYPICAL CHARACTERISTICS

RECEIVER HIGH-TO-LOW LEVEL
PROPAGATION DELAY TIMES
VS
FREE-AIR TEMPERATURE

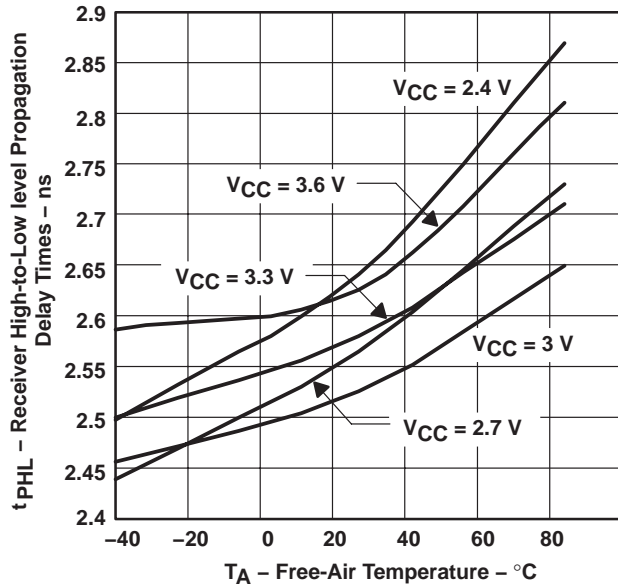

Figure 11

RECEIVER LOW-TO-HIGH LEVEL
PROPAGATION DELAY TIMES
VS
FREE-AIR TEMPERATURE

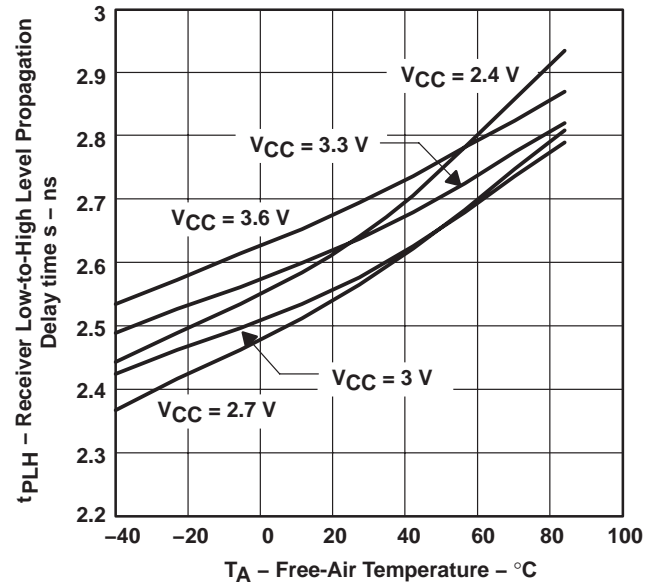

Figure 12

SN65LVDS1, SN65LVDS2, SN65LVDT2 HIGH-SPEED DIFFERENTIAL LINE DRIVER/RECEIVERS

SLLS373F – JULY 1999 – REVISED JULY 2002

APPLICATION INFORMATION

fail-safe

One of the most common problems with differential signaling applications is how the system responds when no differential voltage is present on the signal pair. The LVDS receiver is like most differential line receivers, in that its output logic state can be indeterminate when the differential input voltage is between -100 mV and 100 mV and within its recommended input common-mode voltage range. However, TI's LVDS receiver is different in how it handles the open-input circuit situation.

Open circuit means that there is little or no input current to the receiver from the data line itself. This could be when the driver is in a high-impedance state or the cable is disconnected. When this occurs, the LVDS receiver pulls each line of the signal pair to near V_{CC} through $300\text{-k}\Omega$ resistors as shown in Figure 13. The fail-safe feature uses an AND gate with input voltage thresholds at about 2.3 V to detect this condition and force the output to a high level regardless of the differential input voltage.

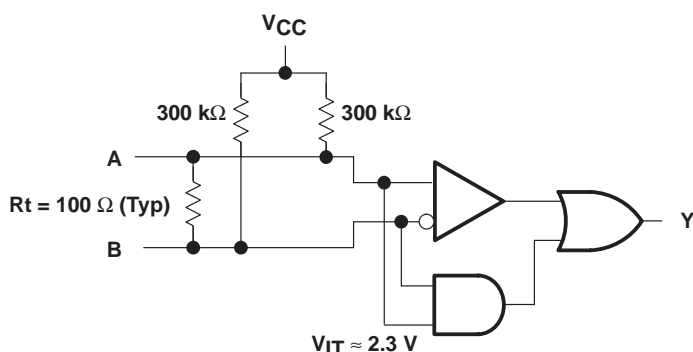
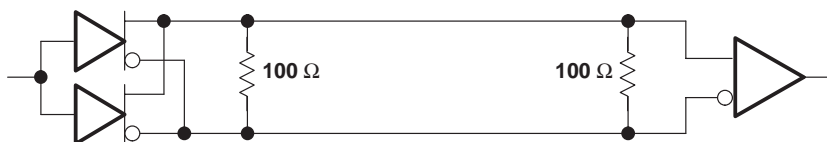

Figure 13. Open-Circuit Fail Safe of the LVDS Receiver

It is only under these conditions that the output of the receiver is valid with less than a 100 mV differential input voltage magnitude. The presence of the termination resistor, R_t , does not affect the fail-safe function as long as it is connected as shown in the figure. Other termination circuits may allow a dc current to ground that could defeat the pullup currents from the receiver and the fail-safe feature.

APPLICATION INFORMATION

Parallel Terminated



Point to Point

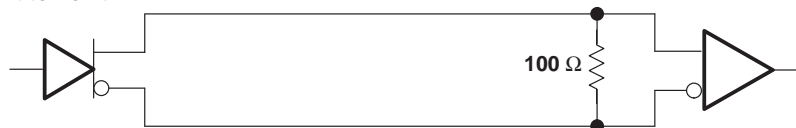

Multidrop

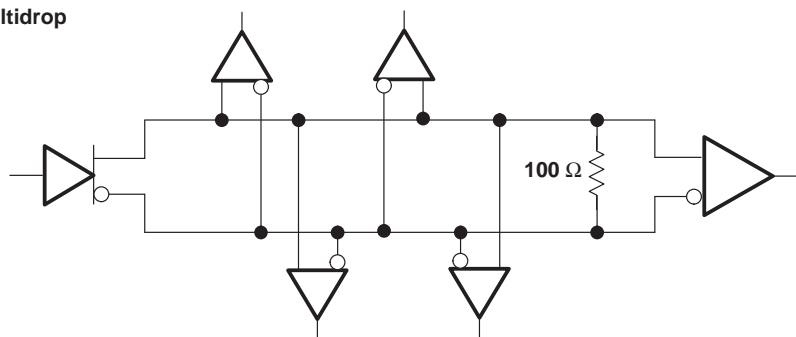

Figure 14. Typical Application Circuits

SN65LVDS1, SN65LVDS2, SN65LVDT2 HIGH-SPEED DIFFERENTIAL LINE DRIVER/RECEIVERS

SLLS373F – JULY 1999 – REVISED JULY 2002

MECHANICAL INFORMATION

D (R-PDSO-G**)

PLASTIC SMALL-OUTLINE PACKAGE

14 PINS SHOWN

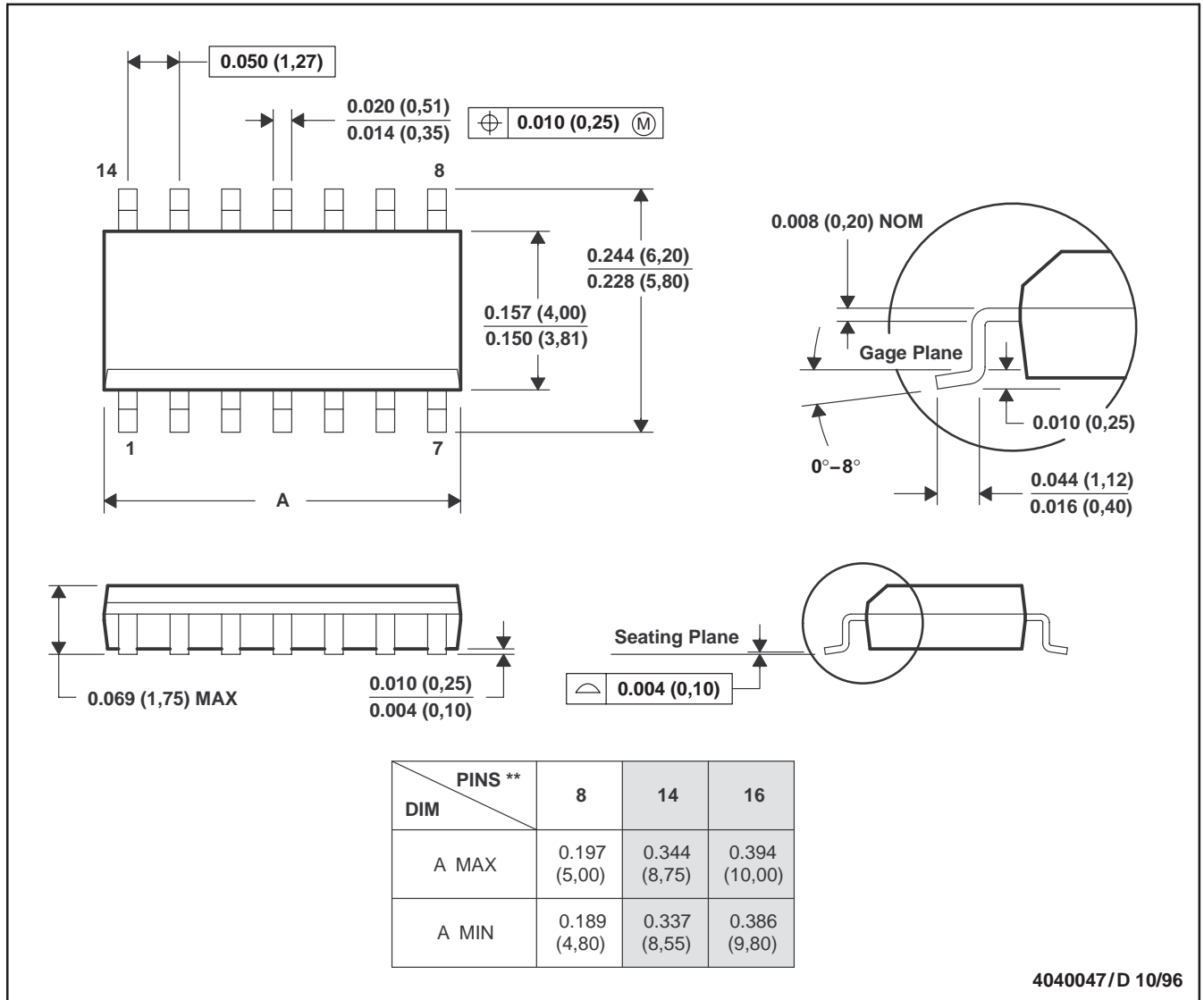

- NOTES: A. All linear dimensions are in inches (millimeters).
 B. This drawing is subject to change without notice.
 C. Body dimensions do not include mold flash or protrusion, not to exceed 0.006 (0,15).
 D. Falls within JEDEC MS-012

IMPORTANT NOTICE

Texas Instruments Incorporated and its subsidiaries (TI) reserve the right to make corrections, modifications, enhancements, improvements, and other changes to its products and services at any time and to discontinue any product or service without notice. Customers should obtain the latest relevant information before placing orders and should verify that such information is current and complete. All products are sold subject to TI's terms and conditions of sale supplied at the time of order acknowledgment.

TI warrants performance of its hardware products to the specifications applicable at the time of sale in accordance with TI's standard warranty. Testing and other quality control techniques are used to the extent TI deems necessary to support this warranty. Except where mandated by government requirements, testing of all parameters of each product is not necessarily performed.

TI assumes no liability for applications assistance or customer product design. Customers are responsible for their products and applications using TI components. To minimize the risks associated with customer products and applications, customers should provide adequate design and operating safeguards.

TI does not warrant or represent that any license, either express or implied, is granted under any TI patent right, copyright, mask work right, or other TI intellectual property right relating to any combination, machine, or process in which TI products or services are used. Information published by TI regarding third-party products or services does not constitute a license from TI to use such products or services or a warranty or endorsement thereof. Use of such information may require a license from a third party under the patents or other intellectual property of the third party, or a license from TI under the patents or other intellectual property of TI.

Reproduction of information in TI data books or data sheets is permissible only if reproduction is without alteration and is accompanied by all associated warranties, conditions, limitations, and notices. Reproduction of this information with alteration is an unfair and deceptive business practice. TI is not responsible or liable for such altered documentation.

Resale of TI products or services with statements different from or beyond the parameters stated by TI for that product or service voids all express and any implied warranties for the associated TI product or service and is an unfair and deceptive business practice. TI is not responsible or liable for any such statements.

Following are URLs where you can obtain information on other Texas Instruments products and application solutions:

Products		Applications	
Amplifiers	amplifier.ti.com	Audio	www.ti.com/audio
Data Converters	dataconverter.ti.com	Automotive	www.ti.com/automotive
DSP	dsp.ti.com	Broadband	www.ti.com/broadband
Interface	interface.ti.com	Digital Control	www.ti.com/digitalcontrol
Logic	logic.ti.com	Military	www.ti.com/military
Power Mgmt	power.ti.com	Optical Networking	www.ti.com/opticalnetwork
Microcontrollers	microcontroller.ti.com	Security	www.ti.com/security
		Telephony	www.ti.com/telephony
		Video & Imaging	www.ti.com/video
		Wireless	www.ti.com/wireless

Mailing Address: Texas Instruments
Post Office Box 655303 Dallas, Texas 75265