

SN65LBC174, SN75LBC174 QUADRUPLE LOW-POWER DIFFERENTIAL LINE DRIVERS

SLLS162D – JULY 1993 – REVISED SEPTEMBER 2003

- Meets or Exceeds the Standard EIA-485
- Designed for High-Speed Multipoint Transmission on Long Bus Lines in Noisy Environments
- Supports Data Rates up to and Exceeding Ten Million Transfers Per Second
- Common-Mode Output Voltage Range of -7 V to 12 V
- Positive- and Negative-Current Limiting
- Low Power Consumption . . . 1.5 mA Max (Output Disabled)
- Functionally Interchangeable With SN75174

description

The SN65LBC174 and SN75LBC174 are monolithic, quadruple, differential line drivers with 3-state outputs. Both devices are designed to meet the requirements of the Electronics Industry Association Standard EIA-485. These devices are optimized for balanced multipoint bus transmission at data rates up to and exceeding 10 million bits per second. Each driver features wide positive and negative common-mode output voltage ranges, current limiting, and thermal-shutdown protection, making it suitable for party-line applications in noisy environments. Both devices are designed using LinBiCMOS™, facilitating ultralow power consumption and inherent robustness.

Both the SN65LBC174 and SN75LBC174 provide positive- and negative-current limiting and thermal shutdown for protection from line fault conditions on the transmission bus line. These devices offer optimum performance when used with the SN75LBC173 or SN75LBC175 quadruple line receivers. The SN65LBC174 and SN75LBC174 are available in the 16-terminal DIP package (N) and the 20-terminal wide-body small outline intergrated circuit (SOIC) package (DW).

The SN75LBC174 is characterized for operation over the commercial temperature range of 0°C to 70°C . The SN65LBC174 is characterized over the industrial temperature range of -40°C to 85°C .

**N PACKAGE
(TOP VIEW)**

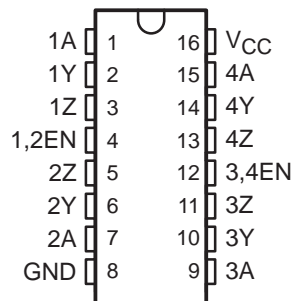

**DW PACKAGE
(TOP VIEW)**

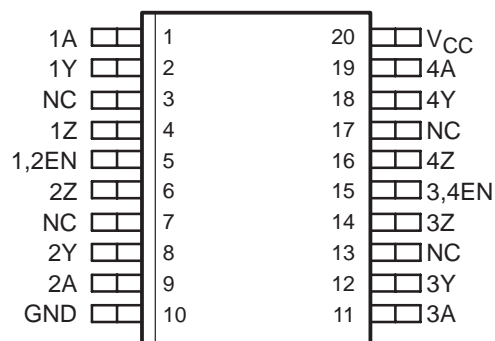

NC – No internal connection

**FUNCTION TABLE
(each driver)**

INPUT	ENABLE	OUTPUTS	
		Y	Z
H	H	H	L
L	H	L	H
X	L	Z	Z

H = high level, L = low level,
X = irrelevant, Z = high impedance (off)



Please be aware that an important notice concerning availability, standard warranty, and use in critical applications of Texas Instruments semiconductor products and disclaimers thereto appears at the end of this data sheet.

LinBiCMOS is a trademark of Texas Instruments Incorporated.

PRODUCTION DATA information is current as of publication date. Products conform to specifications per the terms of Texas Instruments standard warranty. Production processing does not necessarily include testing of all parameters.



POST OFFICE BOX 655303 • DALLAS, TEXAS 75265

Copyright © 2001–2003, Texas Instruments Incorporated

SN65LBC174, SN75LBC174 QUADRUPLE LOW-POWER DIFFERENTIAL LINE DRIVERS

SLLS162D – JULY 1993 – REVISED SEPTEMBER 2003

logic symbol†

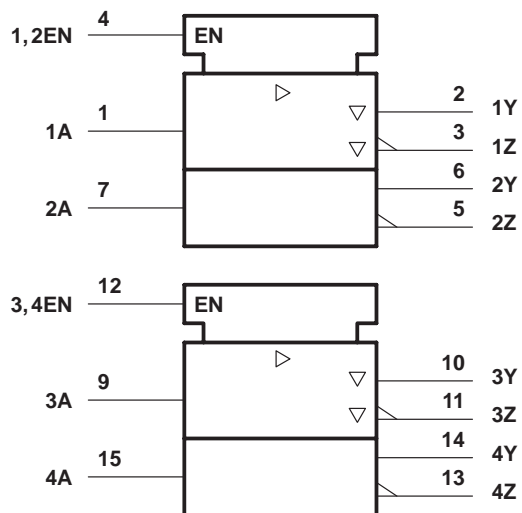

logic diagram (positive logic)

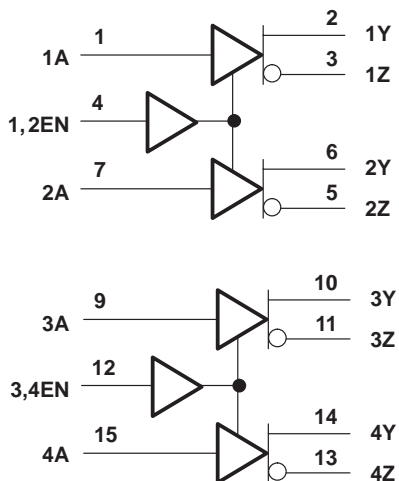

† This symbol is in accordance with ANSI/IEEE Std 91-1984 and IEC Publication 617-12.

Terminal numbers shown are for the N package.

schematic of inputs and outputs

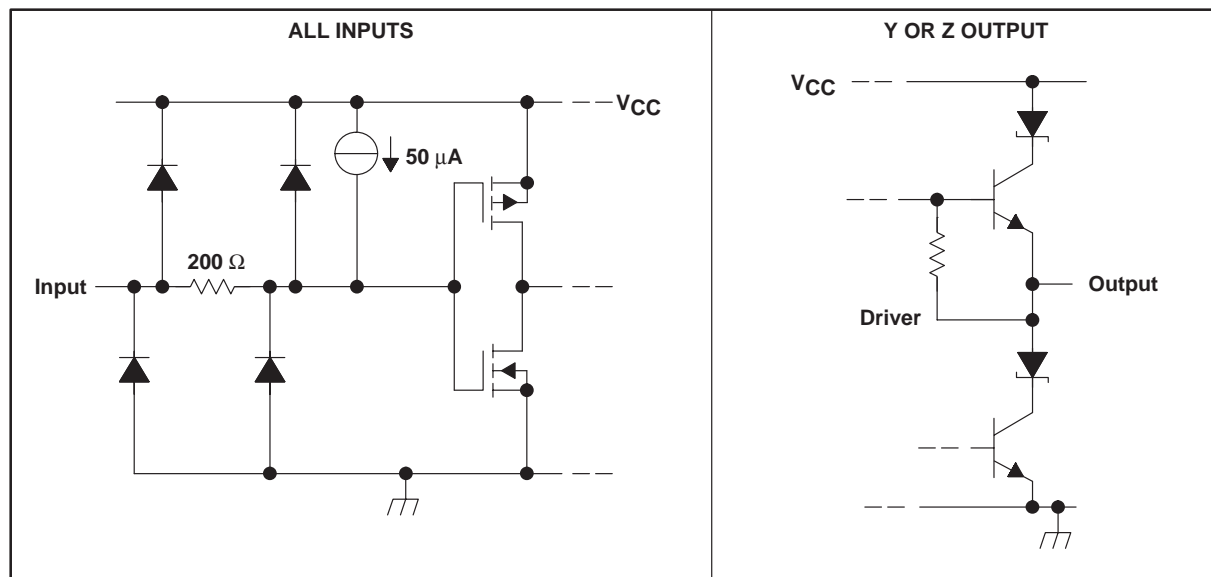

SN65LBC174, SN75LBC174 QUADRUPLE LOW-POWER DIFFERENTIAL LINE DRIVERS

SLLS162D – JULY 1993 – REVISED SEPTEMBER 2003

absolute maximum ratings over operating free-air temperature (unless otherwise noted)†

Supply voltage range, V_{CC} (see Note 1)	–0.3 V to 7 V
Output voltage range, V_O	–10 V to 15 V
Voltage range at A, 1/2EN, 3/4EN	–0.3 V to $V_{CC} + 0.5$ V
Continuous total power dissipation	Internally limited‡
Operating free-air temperature range, T_A : SN65LBC174	–40°C to 85°C
SN75LBC174	0°C to 70°C
Storage temperature range, T_{stg}	–65°C to 150°C
Lead temperature 1,6 mm (1/16 inch) from case for 10 seconds	260°C

† Stresses beyond those listed under “absolute maximum ratings” may cause permanent damage to the device. These are stress ratings only, and functional operation of the device at these or any other conditions beyond those indicated under “recommended operating conditions” is not implied. Exposure to absolute-maximum-rated conditions for extended periods may affect device reliability.

‡ The maximum operating junction temperature is internally limited. Use the Dissipation Rating Table to operate below this temperature.

NOTE 1: All voltage values are with respect to GND.

recommended operating conditions

		MIN	NOM	MAX	UNIT
Supply voltage, V_{CC}		4.75	5	5.25	V
High-level input voltage, V_{IH}		2			V
Low-level input voltage, V_{IL}		0.8			V
Voltage at any bus terminal (separately or common-mode), V_O	Y or Z	12			V
		–7			
High-level output current, I_{OH}	Y or Z	–60			mA
Low-level output current, I_{OL}	Y or Z	60			mA
Continuous total power dissipation		See Dissipation Rating Table			
Operating free-air temperature, T_A	SN65LBC174	–40			°C
	SN75LBC174	0	70		

DISSIPATION RATING TABLE

PACKAGE	$T_A \leq 25^\circ\text{C}$	DERATING FACTOR	$T_A = 70^\circ\text{C}$	$T_A = 85^\circ\text{C}$
	POWER RATING	ABOVE $T_A = 25^\circ\text{C}$	POWER RATING	POWER RATING
DW	1125 mW	9.0 mW/°C	720 mW	585 mW
N	1150 mW	9.2 mW/°C	736 mW	598 mW

SN65LBC174, SN75LBC174 QUADRUPLE LOW-POWER DIFFERENTIAL LINE DRIVERS

SLLS162D – JULY 1993 – REVISED SEPTEMBER 2003

electrical characteristics over recommended ranges of supply voltage and operating free-air temperature (unless otherwise noted)

PARAMETER		TEST CONDITIONS		MIN	TYP†	MAX	UNIT
V _{IK}	Input clamp voltage	I _I = -18 mA				-1.5	V
V _{OD}	Differential output voltage‡	R _L = 54 Ω, See Figure 1	SN65LBC174	1.1	1.8	5	V
			SN75LBC174	1.5	1.8	5	
		R _L = 60 Ω, See Figure 2	SN65LBC174	1.1	1.7	5	
			SN75LBC174	1.5	1.7	5	
Δ V _{OD}	Change in magnitude of common-mode output voltage§					±0.2	V
V _{OC}	Common-mode output voltage	R _L = 54 Ω, See Figure 1				3 -1	V
Δ V _{OC}	Change in magnitude of common-mode output voltage§					±0.2	V
I _O	Output current with power off	V _{CC} = 0, V _O = -7 V to 12 V				±100	μA
I _{OZ}	High-impedance-state output current	V _O = -7 V to 12 V				±100	μA
I _{IH}	High-level input current	V _I = 2.4 V				-100	μA
I _{IL}	Low-level input current	V _I = 0.4 V				-100	μA
I _{OS}	Short-circuit output current	V _O = -7 V to 12 V				±250	mA
I _{CC}	Supply current (all drivers)	No load	Outputs enabled			7	mA
			Outputs disabled			1.5	

† All typical values are at V_{CC} = 5 V and T_A = 25°C.

‡ The minimum V_{OD} specification does not fully comply with EIA-485 at operating temperatures below 0°C. The lower output signal should be used to determine the maximum signal transmission distance.

§ Δ|V_{OD}| and Δ|V_{OC}| are the changes in magnitude of V_{OD} and V_{OC}, respectively, that occur when the input is changed from a high level to a low level.

switching characteristics, V_{CC} = 5 V, T_A = 25°C

PARAMETER		TEST CONDITIONS		MIN	TYP	MAX	UNIT	
t _{d(OD)}	Differential output delay time	R _L = 54 Ω, See Figure 3			2	11	20	ns
t _{t(OD)}	Differential output transition time				10	15	25	ns
t _{PZH}	Output enable time to high level	R _L = 110 Ω, See Figure 3				20	30	ns
t _{PZL}	Output enable time to low level	R _L = 110 Ω, See Figure 5				21	30	ns
t _{PHZ}	Output disable time from high level	R _L = 110 Ω, See Figure 4				48	70	ns
t _{PLZ}	Output disable time from low level	R _L = 110 Ω, See Figure 5				21	30	ns



PARAMETER MEASUREMENT INFORMATION

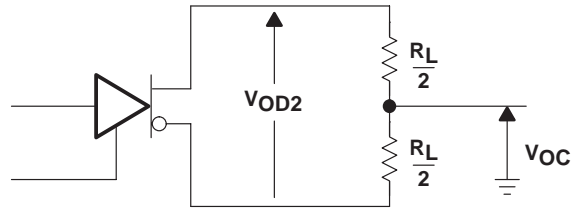

Figure 1. Differential and Common-Mode Output Voltages

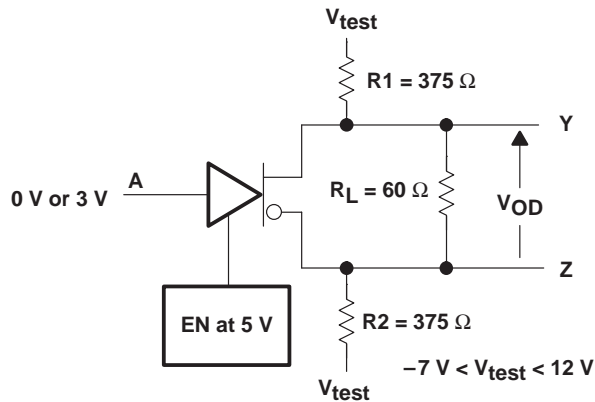
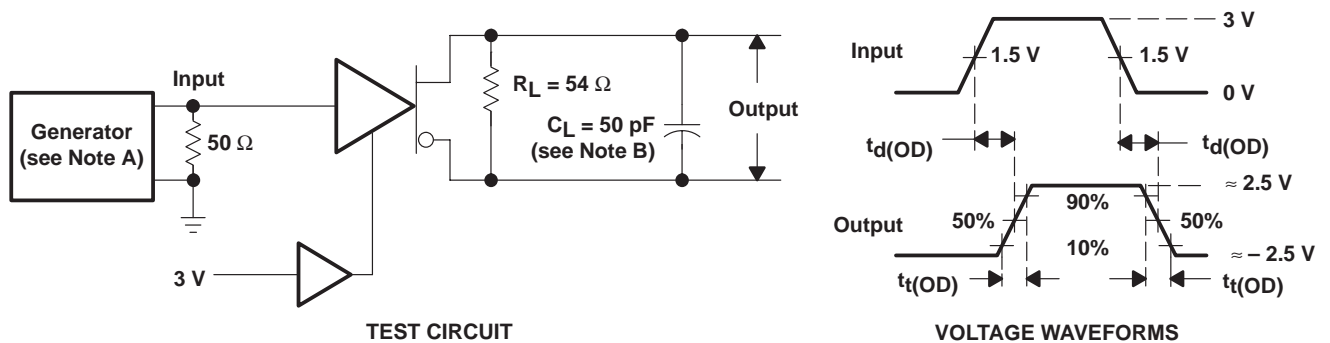

Figure 2. Driver V_{OD} Test Circuit



- NOTES: A. The input pulse is supplied by a generator having the following characteristics: $PRR \leq 1$ MHz, duty cycle = 50%, $t_r \leq 5$ ns, $t_f \leq 5$ ns, $Z_O = 50 \Omega$.
 B. C_L includes probe and stray capacitance.

Figure 3. Time Waveforms for Driver Differential Output Test Circuit Delay and Transition

SN65LBC174, SN75LBC174 QUADRUPLE LOW-POWER DIFFERENTIAL LINE DRIVERS

SLLS162D – JULY 1993 – REVISED SEPTEMBER 2003

PARAMETER MEASUREMENT INFORMATION

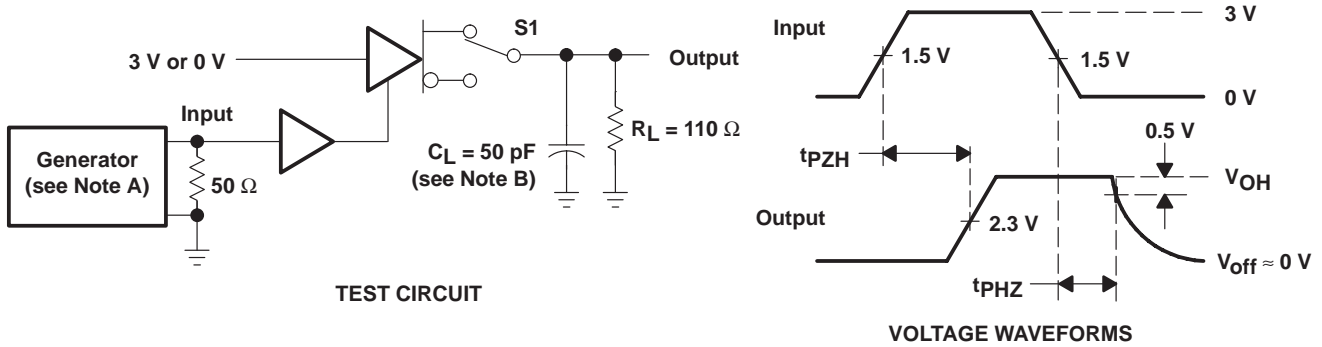
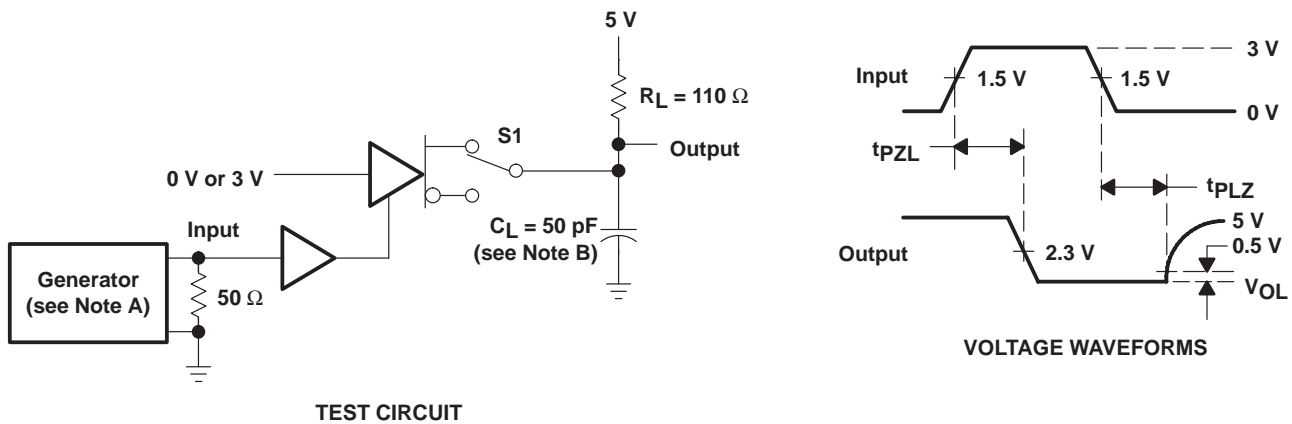

Figure 4. t_{pZH} and t_{pHZ} Test Circuit and Waveforms



- NOTES: A. The input pulse is supplied by a generator having the following characteristics: $PRR \leq 1$ MHz, duty cycle = 50%, $t_r \leq 5$ ns, $t_f \leq 5$ ns, $Z_O = 50 \Omega$.
 B. C_L includes probe and stray capacitance.

Figure 5. t_{pZL} and t_{pLZ} Test Circuit and Waveforms

TYPICAL CHARACTERISTICS

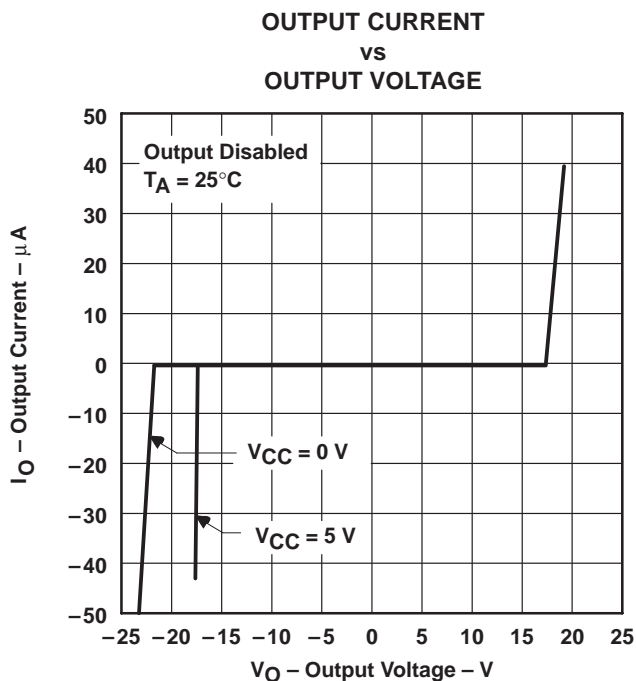

Figure 6

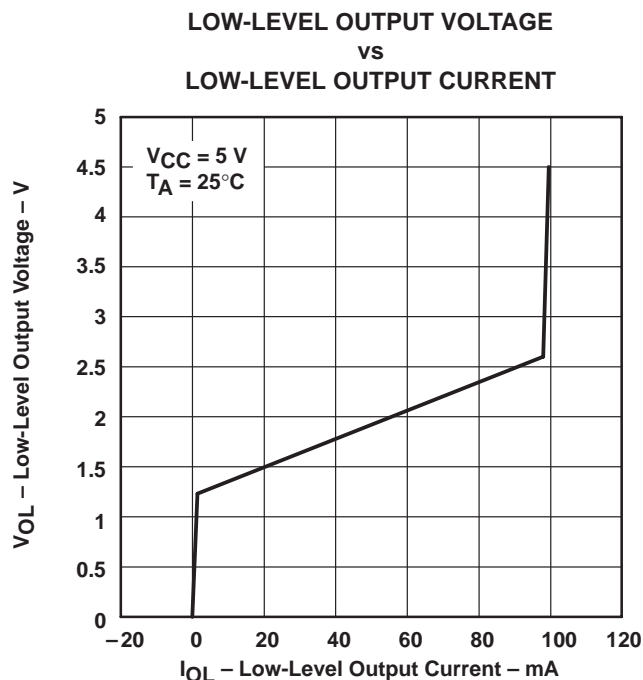

Figure 7

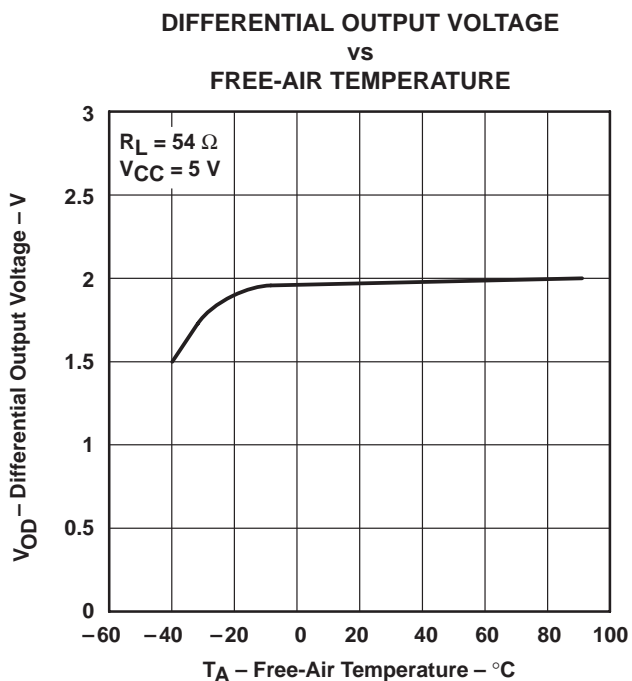

Figure 8

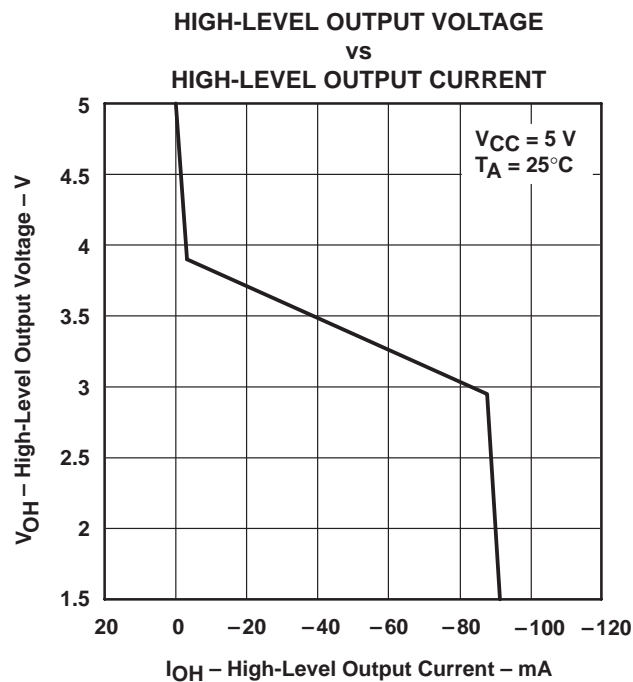
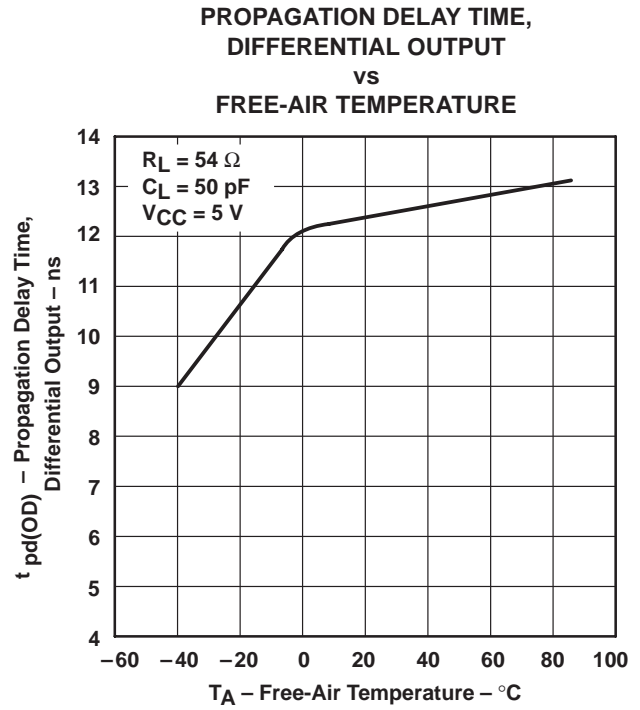
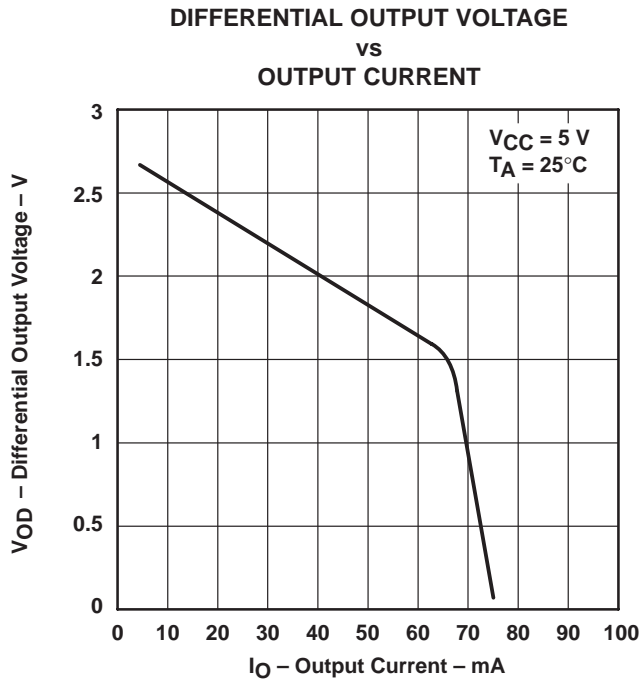

Figure 9

SN65LBC174, SN75LBC174 QUADRUPLE LOW-POWER DIFFERENTIAL LINE DRIVERS

SLLS162D – JULY 1993 – REVISED SEPTEMBER 2003

TYPICAL CHARACTERISTICS



SN65LBC174, SN75LBC174 QUADRUPLE LOW-POWER DIFFERENTIAL LINE DRIVERS

SLLS162D – JULY 1993 – REVISED SEPTEMBER 2003

MECHANICAL DATA

DW (R-PDSO-G)**

PLASTIC SMALL-OUTLINE PACKAGE

16 PIN SHOWN

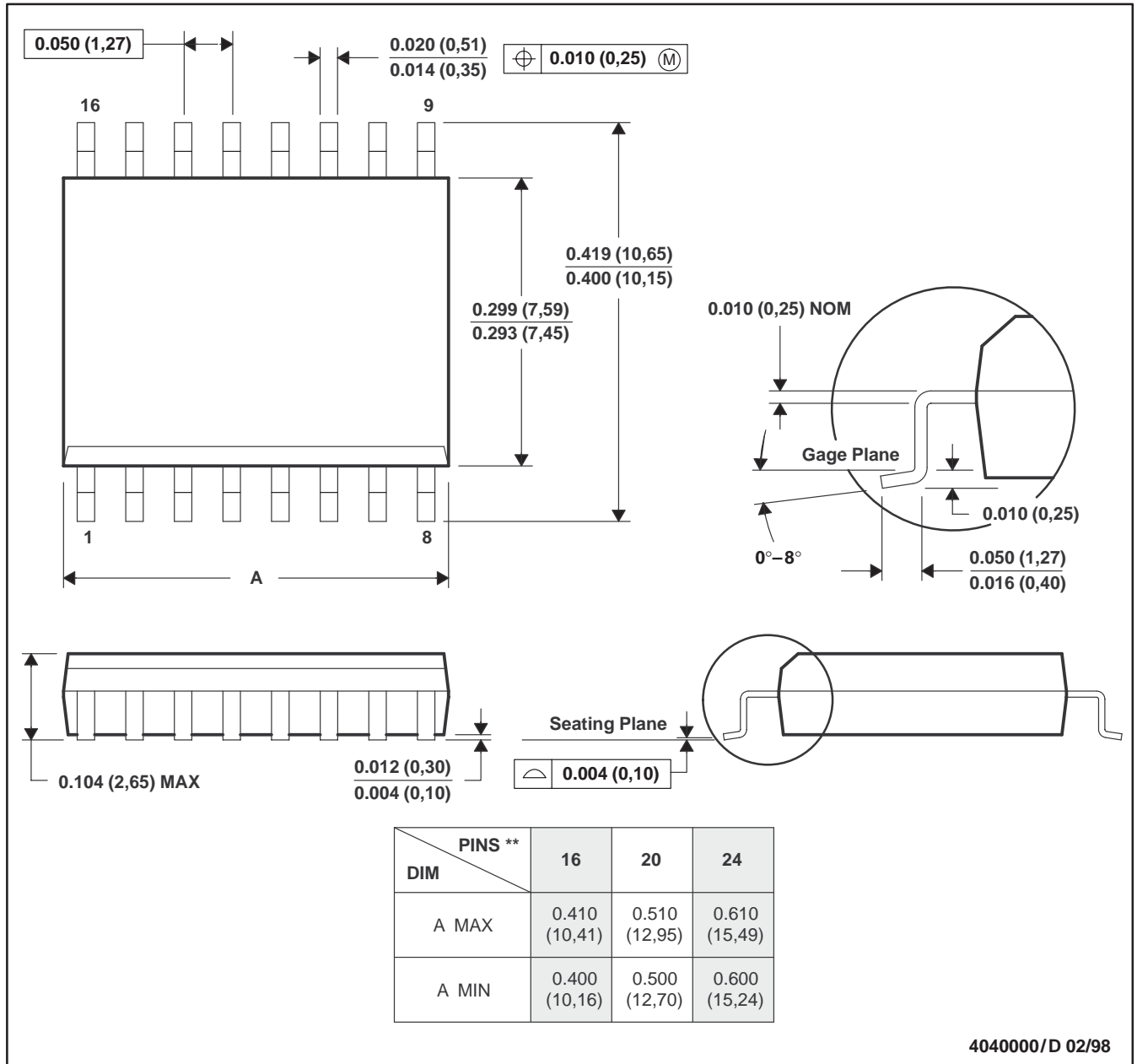

- NOTES: A. All linear dimensions are in inches (millimeters).
 B. This drawing is subject to change without notice.
 C. Body dimensions do not include mold flash or protrusion not to exceed 0.006 (0,15).
 D. Falls within JEDEC MS-013

SN65LBC174, SN75LBC174 QUADRUPLE LOW-POWER DIFFERENTIAL LINE DRIVERS

SLLS162D – JULY 1993 – REVISED SEPTEMBER 2003

MECHANICAL DATA

N (R-PDIP-T**)

PLASTIC DUAL-IN-LINE PACKAGE

16 PIN SHOWN

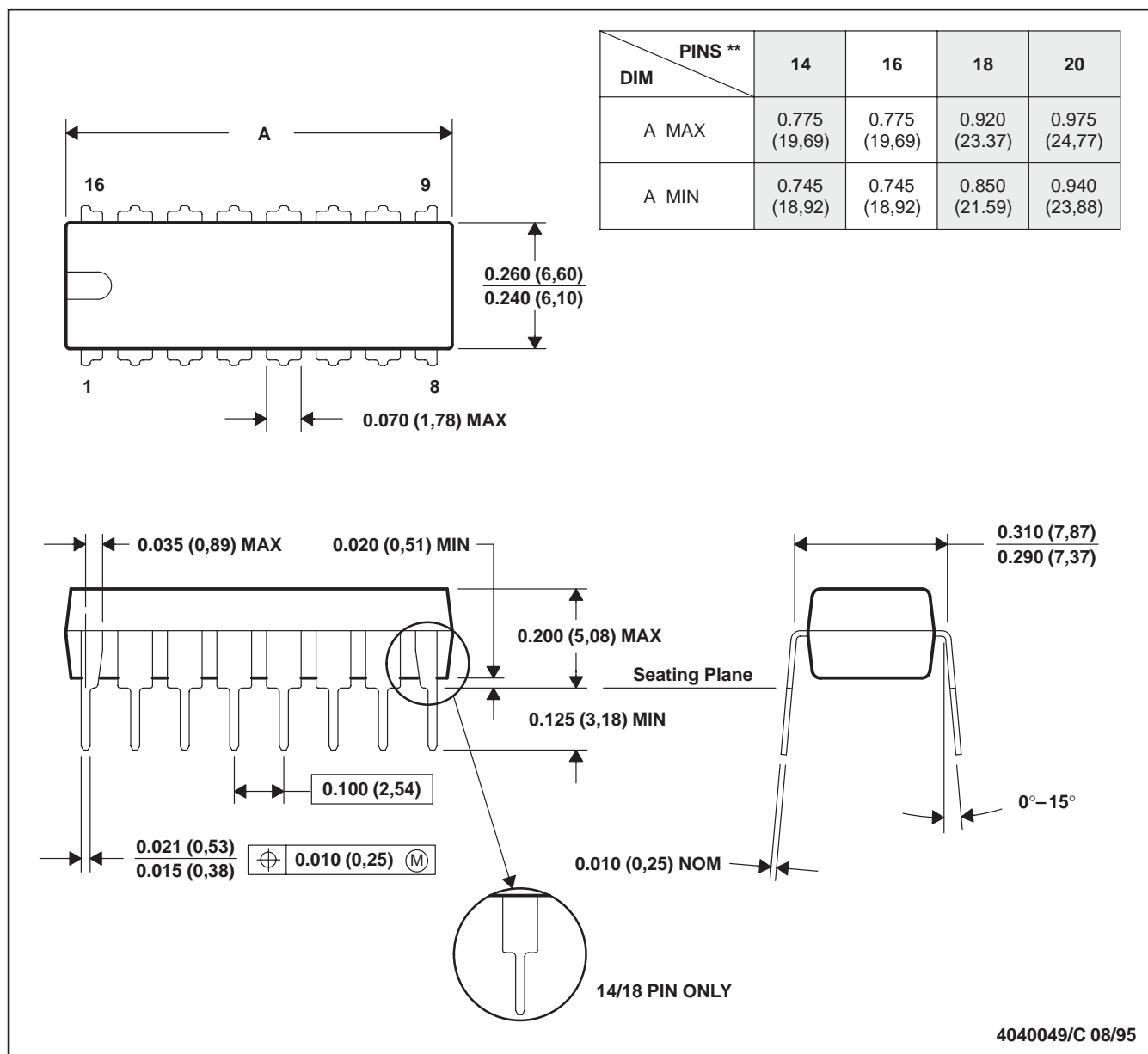

- NOTES: A. All linear dimensions are in inches (millimeters).
 B. This drawing is subject to change without notice.
 C. Falls within JEDEC MS-001 (20 pin package is shorter than MS-001.)

IMPORTANT NOTICE

Texas Instruments Incorporated and its subsidiaries (TI) reserve the right to make corrections, modifications, enhancements, improvements, and other changes to its products and services at any time and to discontinue any product or service without notice. Customers should obtain the latest relevant information before placing orders and should verify that such information is current and complete. All products are sold subject to TI's terms and conditions of sale supplied at the time of order acknowledgment.

TI warrants performance of its hardware products to the specifications applicable at the time of sale in accordance with TI's standard warranty. Testing and other quality control techniques are used to the extent TI deems necessary to support this warranty. Except where mandated by government requirements, testing of all parameters of each product is not necessarily performed.

TI assumes no liability for applications assistance or customer product design. Customers are responsible for their products and applications using TI components. To minimize the risks associated with customer products and applications, customers should provide adequate design and operating safeguards.

TI does not warrant or represent that any license, either express or implied, is granted under any TI patent right, copyright, mask work right, or other TI intellectual property right relating to any combination, machine, or process in which TI products or services are used. Information published by TI regarding third-party products or services does not constitute a license from TI to use such products or services or a warranty or endorsement thereof. Use of such information may require a license from a third party under the patents or other intellectual property of the third party, or a license from TI under the patents or other intellectual property of TI.

Reproduction of information in TI data books or data sheets is permissible only if reproduction is without alteration and is accompanied by all associated warranties, conditions, limitations, and notices. Reproduction of this information with alteration is an unfair and deceptive business practice. TI is not responsible or liable for such altered documentation.

Resale of TI products or services with statements different from or beyond the parameters stated by TI for that product or service voids all express and any implied warranties for the associated TI product or service and is an unfair and deceptive business practice. TI is not responsible or liable for any such statements.

Following are URLs where you can obtain information on other Texas Instruments products and application solutions:

Products		Applications	
Amplifiers	amplifier.ti.com	Audio	www.ti.com/audio
Data Converters	dataconverter.ti.com	Automotive	www.ti.com/automotive
DSP	dsp.ti.com	Broadband	www.ti.com/broadband
Interface	interface.ti.com	Digital Control	www.ti.com/digitalcontrol
Logic	logic.ti.com	Military	www.ti.com/military
Power Mgmt	power.ti.com	Optical Networking	www.ti.com/opticalnetwork
Microcontrollers	microcontroller.ti.com	Security	www.ti.com/security
		Telephony	www.ti.com/telephony
		Video & Imaging	www.ti.com/video
		Wireless	www.ti.com/wireless

Mailing Address: Texas Instruments
Post Office Box 655303 Dallas, Texas 75265

Copyright © 2003, Texas Instruments Incorporated