

## SNx52x0 USB Port Transient Suppressors

### 1 Features

- Design to Protect Submicron 3-V or 5-V Circuits from Noise Transients
- Port ESD Protection Capability Exceeds:
  - 15-kV Human Body Model
  - 2-kV Machine Model
- Available in a WCSP Chip-Scale Package
- Stand-Off Voltage: 6 V (Min)
- Low Current Leakage: 1- $\mu$ A Max at 6 V
- Low Capacitance: 35-pF (Typ)

### 2 Applications

- USB Full-Speed Host, HUB, or Peripheral
- Ports

### 3 Description

The SN65220 device is a dual, and the SN65240 and SN75240 devices are quadruple, unidirectional transient voltage suppressors (TVS). These devices provide electrical noise transient protection to Universal Serial Bus (USB) low and full-speed ports. The input capacitance of 35 pF makes it unsuitable for high-speed USB 2.0 applications.

Any cabled I/O can be subjected to electrical noise transients from various sources. These noise transients can cause damage to the USB transceiver and/or the USB ASIC if they are of sufficient magnitude and duration.

The ESD performance of the SN65220, SN65240, and SN75240 devices is measured at the system level, according to IEC61000-4-2. However, system design impacts the results of these tests. To accomplish a high compliance level requires careful board design and layout techniques.

#### Device Information<sup>(1)</sup>

PART NUMBER	PACKAGE	BODY SIZE (NOM)
SN65220	SOT-23 (6)	2.90 mm x 1.60 mm
	DSBGA (4)	0.925 mm x 0.925 mm
SN65240	PDIP (8)	9.09 mm x 6.35 mm
SN75240	TSSOP (8)	3.00 mm x 4.40 mm

(1) For all available packages, see the orderable addendum at the end of the data sheet.

### 4 Simplified Schematic

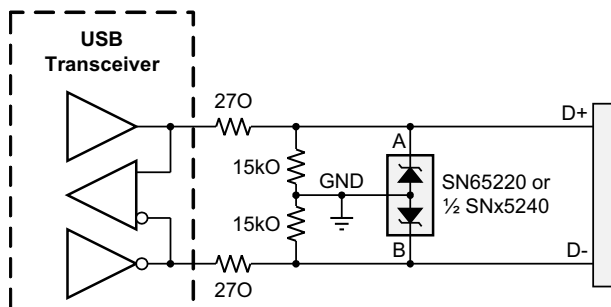

#### TVS Current vs Voltage

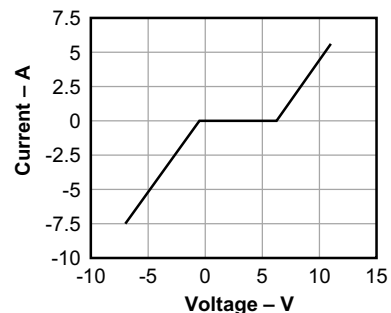

## Table of Contents

<b>1 Features</b> .....	<b>1</b>	10.2 Functional Block Diagram .....	<b>6</b>
<b>2 Applications</b> .....	<b>1</b>	10.3 Feature Description .....	<b>7</b>
<b>3 Description</b> .....	<b>1</b>	10.4 Device Functional Modes .....	<b>7</b>
<b>4 Simplified Schematic</b> .....	<b>1</b>	<b>11 Application and Implementation</b> .....	<b>8</b>
<b>5 Revision History</b> .....	<b>2</b>	11.1 Application Information .....	<b>8</b>
<b>6 Device Comparison Table</b> .....	<b>3</b>	11.2 Typical Application .....	<b>8</b>
<b>7 Pin Configuration and Functions</b> .....	<b>3</b>	<b>12 Power Supply Recommendations</b> .....	<b>10</b>
<b>8 Specifications</b> .....	<b>4</b>	<b>13 Layout</b> .....	<b>10</b>
8.1 Absolute Maximum Ratings .....	<b>4</b>	13.1 Layout Guidelines .....	<b>10</b>
8.2 ESD Ratings .....	<b>4</b>	13.2 Layout Example .....	<b>10</b>
8.3 Recommended Operating Conditions .....	<b>4</b>	<b>14 Device and Documentation Support</b> .....	<b>11</b>
8.4 Thermal Information .....	<b>4</b>	14.1 Related Links .....	<b>11</b>
8.5 Electrical Characteristics .....	<b>4</b>	14.2 Community Resources .....	<b>11</b>
8.6 Typical Characteristics .....	<b>5</b>	14.3 Trademarks .....	<b>11</b>
<b>9 Parameter Measurement Information</b> .....	<b>5</b>	14.4 Electrostatic Discharge Caution .....	<b>11</b>
<b>10 Detailed Description</b> .....	<b>6</b>	14.5 Glossary .....	<b>11</b>
10.1 Overview .....	<b>6</b>	<b>15 Mechanical, Packaging, and Orderable Information</b> .....	<b>11</b>

## 5 Revision History

### Changes from Revision G (August 2008) to Revision H

Page

<ul style="list-style-type: none"> <li>Added <i>Pin Configuration and Functions</i> section, <i>ESD</i> table, <i>Thermal Information</i> table, <i>Feature Description</i> section, <i>Device Functional Modes</i>, <i>Application and Implementation</i> section, <i>Power Supply Recommendations</i> section, <i>Layout</i> section, <i>Device and Documentation Support</i> section, and <i>Mechanical, Packaging, and Orderable Information</i> section .....</li> </ul>	<b>1</b>
---	----------

## 6 Device Comparison Table

PRODUCT	SUPPRESSORS	T <sub>A</sub> - RANGE	PACKAGE
SN65220	1	–40°C to 85°C	WCSP-4
			SOT23-6
SN65240	2	–40°C to 85°C	DIP-8
			TSSOP-8
SN75240	2	0°C to 70°C	DIP-8
			TSSOP-8

## 7 Pin Configuration and Functions

**DBV Package  
6-Pin SOT-23  
Top View**

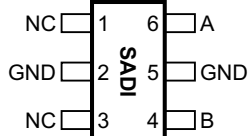

**YZB Package  
4-Pin DSBGA  
Top View**

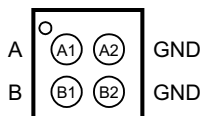

**P, PW Packages  
8-Pin PDIP, TSSOP  
Top View**

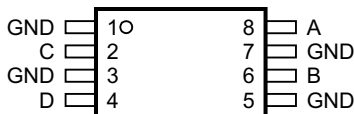

### Pin Functions

NAME	PIN			TYPE	DESCRIPTION
	DBV	YZB	P, PW		
A	6	A1	8	Analog input	Transient suppressor input - Line 1
B	4	B2	6	Analog input	Transient suppressor input - Line 2
C	—	—	2	Analog input	Transient suppressor input - Line 3
D	—	—	4	Analog input	Transient suppressor input - Line 4
GND	2, 5	A2, B2	1, 3, 5, 7	Power	Local device ground
NC	1, 3	—	—	—	Internally not connected

## 8 Specifications

### 8.1 Absolute Maximum Ratings

over operating free-air temperature range (unless otherwise noted)<sup>(1)</sup>

		MIN	MAX	UNIT
$P_{D(\text{peak})}$	Peak power dissipation		60	W
$I_{\text{FSM}}$	Peak forward surge current		3	A
$I_{\text{RSM}}$	Peak reverse surge current		–9	A
$T_{\text{stg}}$	Storage temperature	–65	150	°C

(1) Stresses beyond those listed under *Absolute Maximum Ratings* may cause permanent damage to the device. These are stress ratings only, and functional operation of the device at these or any other conditions beyond those indicated under *Recommended Operating Conditions* is not implied. Exposure to absolute-maximum-rated conditions for extended periods may affect device reliability.

### 8.2 ESD Ratings

		VALUE	UNIT
$V_{\text{(ESD)}}$	Electrostatic discharge		
	Human body model (HBM), per ANSI/ESDA/JEDEC JS-001, all pins <sup>(1)</sup>	±15000	V
Charged device model (CDM), per JEDEC specification JESD22-C101, all pins <sup>(2)</sup>	±2000		

(1) JEDEC document JEP155 states that 500-V HBM allows safe manufacturing with a standard ESD control process.

(2) JEDEC document JEP157 states that 250-V CDM allows safe manufacturing with a standard ESD control process.

### 8.3 Recommended Operating Conditions

		MIN	MAX	UNIT	
$T_A$	Ambient temperature	SN75240	0	70	°C
		SN65220, SN65240	–40	85	

### 8.4 Thermal Information

THERMAL METRIC <sup>(1)</sup>		SN65220		SN65240, SN75240		UNIT
		DBV (SOT-23)	YZB (DSBGA)	P (PDIP)	PW (TSSOP)	
		6 PINS	4 BALLS	8 PINS		
$R_{\theta\text{JA}}$	Junction-to-ambient thermal resistance	199.5	170	67.5	185.3	°C/W
$R_{\theta\text{JC(top)}}$	Junction-to-case (top) thermal resistance	159.7	1.8	57.9	68.8	°C/W
$R_{\theta\text{JB}}$	Junction-to-board thermal resistance	51.1	43.5	44.5	114.0	°C/W
$\psi_{\text{JT}}$	Junction-to-top characterization parameter	41	9.2	36.2	9.9	°C/W
$\psi_{\text{JB}}$	Junction-to-board characterization parameter	50.5	43.5	44.5	112.3	°C/W

(1) For more information about traditional and new thermal metrics, see the *Semiconductor and IC Package Thermal Metrics* application report, [SPRA953](#).

### 8.5 Electrical Characteristics

over recommended operating conditions (unless otherwise noted)

PARAMETER	TEST CONDITIONS	MIN	TYP	MAX	UNIT
$I_{\text{lkq}}$	Leakage current			1	μA
$V_{\text{(BR)}}$	Breakdown voltage	6.5	7	8	V
$C_{\text{IN}}$	Input capacitance to ground		35		pF

## 8.6 Typical Characteristics

$T_A = 25^\circ\text{C}$  unless otherwise noted.

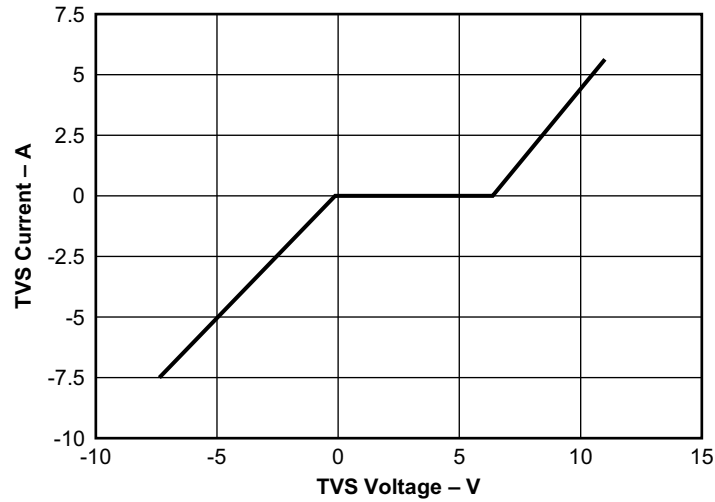

Figure 1. Transient-Voltage-Suppressor Current vs Voltage

## 9 Parameter Measurement Information

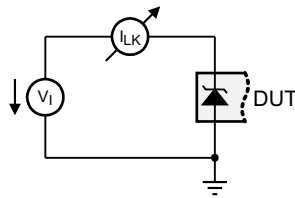

Figure 2. Measurement of Leakage Current

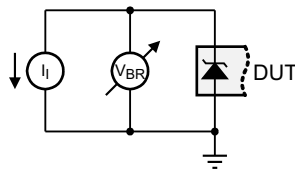

Figure 3. Measurement of Breakdown Voltage

## 10 Detailed Description

### 10.1 Overview

The SN65220, SN65240, and SN75240 devices integrate multiple unidirectional transient voltage suppressors (TVS). Figure 4 shows the equivalent circuit diagram of a single TVS diode.

For positive transient voltages, only the Q1 transistor determines the switching characteristic. When the input voltage reaches the Zener voltage,  $V_Z$ , Zener diode D1 conducts; therefore, allowing for the base-emitter voltage,  $V_{BE}$ , to increase. At  $V_{IN} = V_Z + V_{BE}$ , the transistor starts conducting. From then on, its on-resistance decreases linearly with increasing input voltage.

For negative transient voltages, only diode D2 determines the switching characteristic. Here, switching occurs when the input voltage exceeds the diode forward voltage,  $V_{FW}$ .

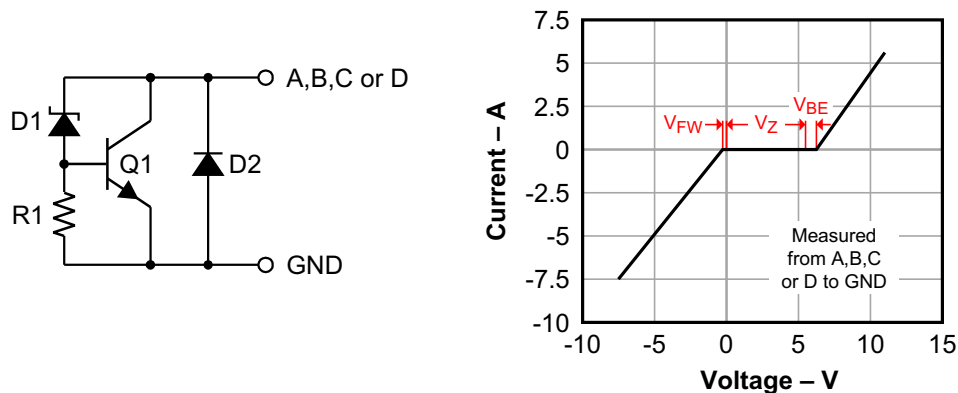
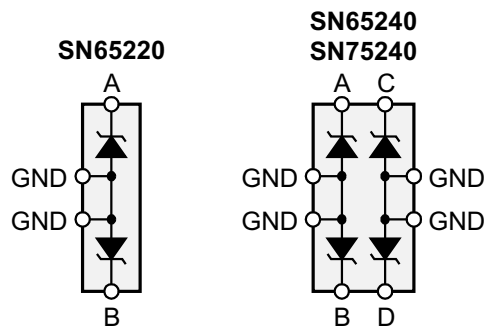

Figure 4. TVS Structure and Current — Voltage Characteristic

### 10.2 Functional Block Diagram



### 10.3 Feature Description

The SN65220, SN65240, and SN75240 family of unidirectional transient voltage suppressors provide transient protection to Universal Serial Bus low and full-speed ports. These TVS diodes provide a minimum breakdown voltage of 6.5V to protect USB transceivers and USB ASICs typically implemented in 3-V or 5-V digital CMOS technology.

### 10.4 Device Functional Modes

TVS diodes possess two functional modes, a high-impedance and a conducting mode.

During normal operating conditions, that is in the absence of high voltage transients, the breakdown voltage of TVS diodes is not exceeded and the devices remain high-impedance.

In the presence of high-voltage transients the breakdown voltage is exceeded. The TVS diodes then conduct and become low-impedance. In this mode excessive transient energy is shunted directly to local circuit ground, preventing USB transceivers from electrical damage.

## 11 Application and Implementation

### NOTE

Information in the following applications sections is not part of the TI component specification, and TI does not warrant its accuracy or completeness. TI's customers are responsible for determining suitability of components for their purposes. Customers should validate and test their design implementation to confirm system functionality.

### 11.1 Application Information

The universal serial bus (USB) has become a popular solution to connect PC peripherals. USB allows devices to be hot-plugged in and out of the existing PC system without rebooting or turning off the PC. Because frequent human interaction with the USB system occurs as a result of its attractive hot-plugging ability, there is the possibility for large ESD strikes and damage to crucial system elements. The ESD protection included on the existing hardware is typically in the 2-kV to 4-kV range for the human body model (HBD) and 200-V to 300-V for the machine model (MM). The ESD voltage levels found in a normal USB operating environment can exceed these levels. The SN75240, SN65240, and SN65220 devices will increase the robustness of the existing USB hardware to ESD strikes common to the environment in which USB is likely to be used.

### 11.2 Typical Application

Figure 5 illustrates a typical USB system and application of the SN75240, SN65240, and SN65220 devices. Connections to pin A from the D+ data line, pin B from the D– data line, and the device grounds from the GND line that already exists are necessary to increase the amount of ESD protection provided to the USB port.

The design of the suppressor gives it very low maximum current leakage of 1  $\mu$ A, a very low typical capacitance of 35 pF, and a standoff voltage minimum of 6 V. Because of these levels, the SN75240, SN65240, and SN65220 devices will provide added protection to the USB system hardware during ESD events without introducing the high capacitance and current leakage levels typical of external transient voltage suppressors. The addition of an SN75240, SN65240, or SN65220 device is beneficial to both full-speed and low-speed USB 1.1 bandwidth standards.

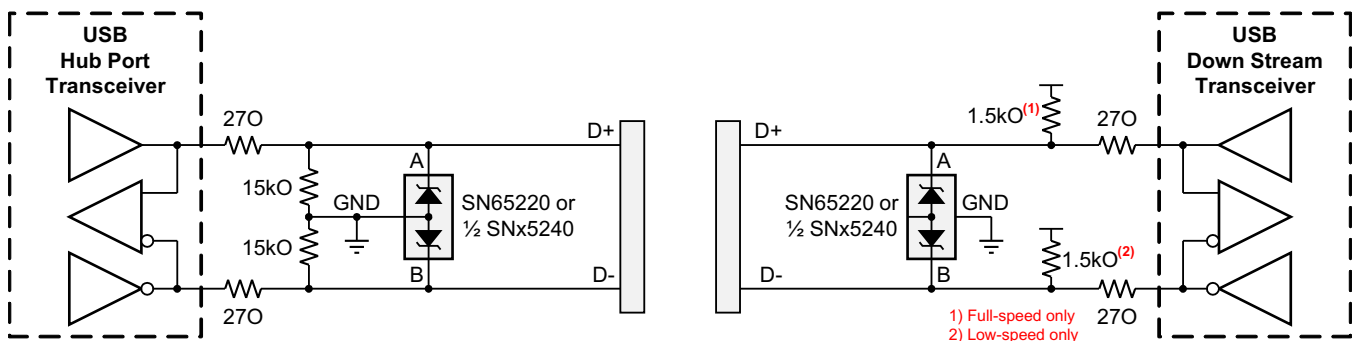

**Figure 5. Typical Application Schematic for ESD Protection of USB Transceivers**

#### 11.2.1 Design Requirements

For this design example, use the parameters listed in Table 1 as design parameters.

**Table 1. Design Parameters**

DESIGN PARAMETER	EXAMPLE VALUE
Minimum breakdown voltage (TVS)	6.5 V
Maximum supply voltage (USB transceiver)	5.5 V
Typical junction capacitance (TVS)	35 pF
Maximum data rate (USB transceiver)	12 Mbps

### 11.2.2 Detailed Design Procedure

To effectively protect USB transceivers, use TVS diodes with breakdown voltages close to 6 V, such as the SN65220, SN65240, or SN75220 devices.

Because of the TVS junction capacitance of 35 pF, apply these TVS diodes only to USB transceivers with full-speed capability that is 12 Mbps maximum.

Place the TVS diodes as close to the board connector as possible to prevent transient energies from entering further board space.

Connect the TVS diode between the data lines (D+, D–) and local circuit ground (GND).

Because noise transient represents high-speed frequencies, ensure low-inductance return paths for the transient currents by providing a solid ground plane and using two VIAs connecting the TVS terminals to ground.

### 11.2.3 Application Curve

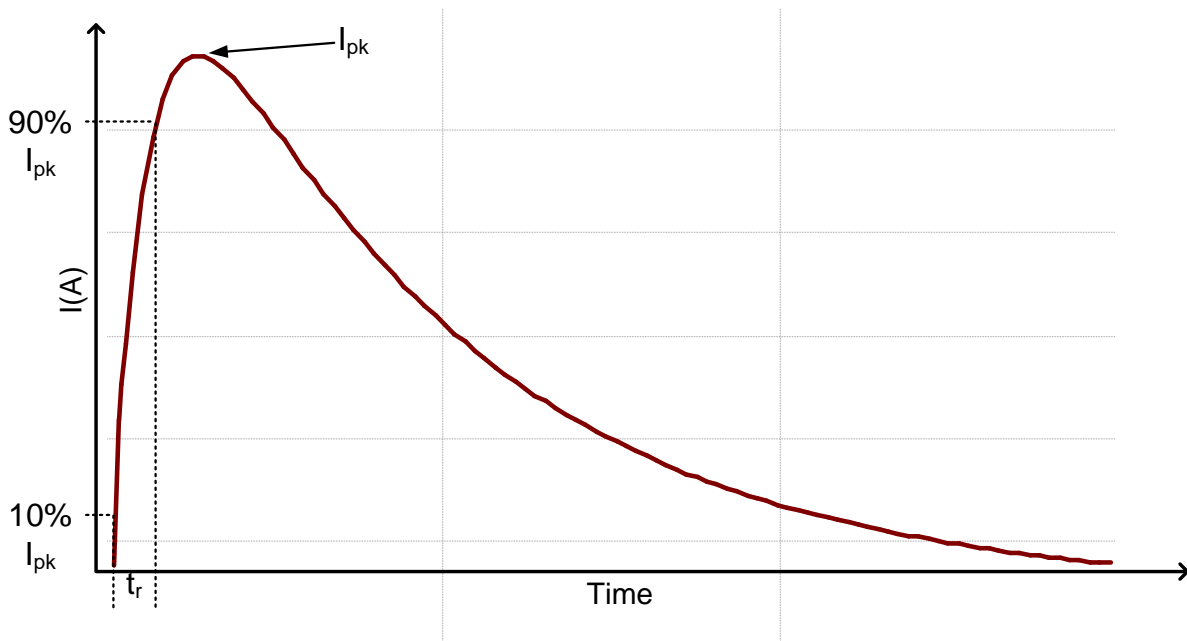

**Figure 6. HBM Curve**

## 12 Power Supply Recommendations

Unlike other semiconductor components that require a supply voltage to operate, the SN65220, SN65240, and SN75240 transient suppressors are combinations of multiple p-n diodes, activated by transient voltages. Therefore, these transient suppressors do not require external voltage supplies.

## 13 Layout

### 13.1 Layout Guidelines

The multiple ground pins provided lower the connection resistance to ground. In order to improve circuit operation, a connection to all ground pins must be provided on the system printed circuit board. Without proper device connection to ground, the speed and protection capability of the device will be degraded.

- The ground termination pads should be connected directly to a ground plane on the board for optimum performance. A single trace ground conductor will not provide an effective path for fast rise-time transient events including ESD due to parasitic inductance.
- Nominal inductive values of a PCB trace are approximately 20 nH/cm. This value may seem small, but an apparent “short length” of trace may be sufficient to produce significant  $L(di/dt)$  effects with fast rise-time ESD spikes.
- Mount the TVS as close as possible to the I/O socket to reduce radiation originating from the transient as it is routed to ground.

#### NOTE

Direct connective paths of the traces are taken to the suppressor mounting pads to minimize parasitic inductance in the surge-current conductive path, thus minimizing  $L(di/dt)$  effects.

### 13.2 Layout Example

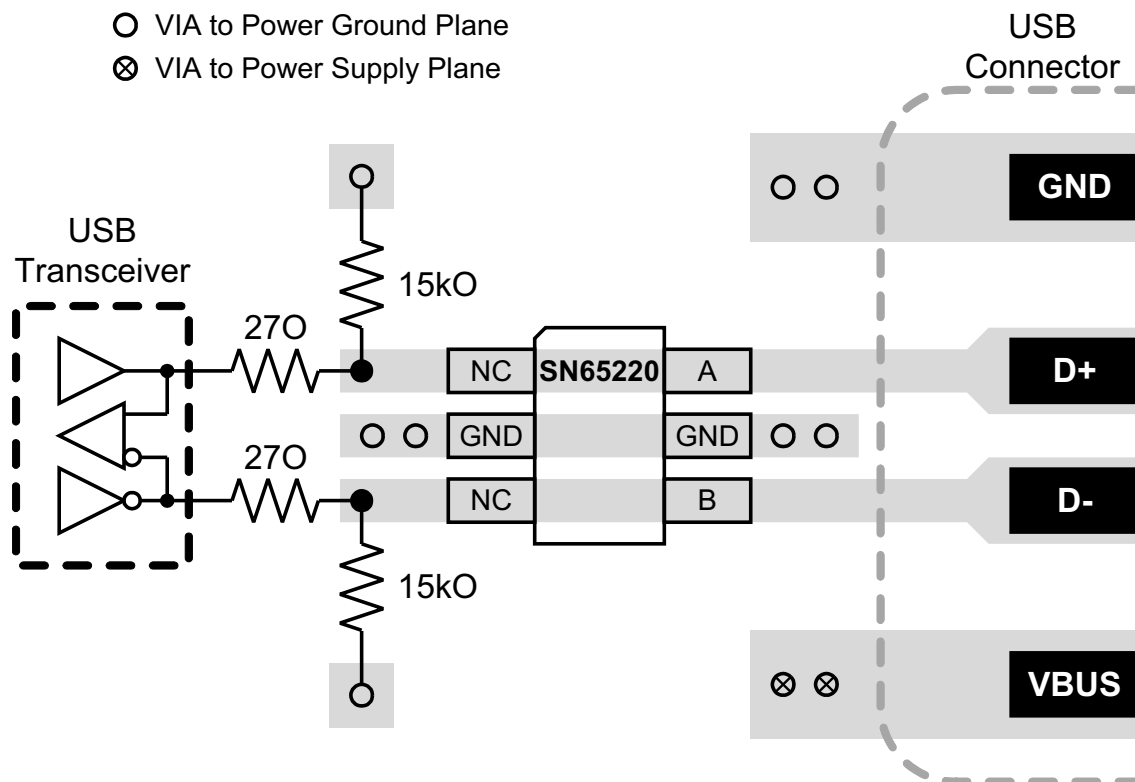

**Figure 7. Layout Example of a 4-Layer Board With SN65220**

## 14 Device and Documentation Support

### 14.1 Related Links

The table below lists quick access links. Categories include technical documents, support and community resources, tools and software, and quick access to sample or buy.

**Table 2. Related Links**

PARTS	PRODUCT FOLDER	SAMPLE & BUY	TECHNICAL DOCUMENTS	TOOLS & SOFTWARE	SUPPORT & COMMUNITY
SN65220	<a href="#">Click here</a>	<a href="#">Click here</a>	<a href="#">Click here</a>	<a href="#">Click here</a>	<a href="#">Click here</a>
SN65240	<a href="#">Click here</a>	<a href="#">Click here</a>	<a href="#">Click here</a>	<a href="#">Click here</a>	<a href="#">Click here</a>
SN75240	<a href="#">Click here</a>	<a href="#">Click here</a>	<a href="#">Click here</a>	<a href="#">Click here</a>	<a href="#">Click here</a>

### 14.2 Community Resources

The following links connect to TI community resources. Linked contents are provided "AS IS" by the respective contributors. They do not constitute TI specifications and do not necessarily reflect TI's views; see TI's [Terms of Use](#).

**TI E2E™ Online Community** *TI's Engineer-to-Engineer (E2E) Community*. Created to foster collaboration among engineers. At [e2e.ti.com](http://e2e.ti.com), you can ask questions, share knowledge, explore ideas and help solve problems with fellow engineers.

**Design Support** *TI's Design Support* Quickly find helpful E2E forums along with design support tools and contact information for technical support.

### 14.3 Trademarks

E2E is a trademark of Texas Instruments.

All other trademarks are the property of their respective owners.

### 14.4 Electrostatic Discharge Caution



These devices have limited built-in ESD protection. The leads should be shorted together or the device placed in conductive foam during storage or handling to prevent electrostatic damage to the MOS gates.

### 14.5 Glossary

[SLYZ022](#) — *TI Glossary*.

This glossary lists and explains terms, acronyms, and definitions.

## 15 Mechanical, Packaging, and Orderable Information

The following pages include mechanical, packaging, and orderable information. This information is the most current data available for the designated devices. This data is subject to change without notice and revision of this document. For browser-based versions of this data sheet, refer to the left-hand navigation.

**PACKAGING INFORMATION**

Orderable Device	Status (1)	Package Type	Package Drawing	Pins	Package Qty	Eco Plan (2)	Lead/Ball Finish (6)	MSL Peak Temp (3)	Op Temp (°C)	Device Marking (4/5)	Samples
SN65220DBVR	ACTIVE	SOT-23	DBV	6	3000	Green (RoHS & no Sb/Br)	CU NIPDAU	Level-1-260C-UNLIM	-40 to 85	SADI	<a href="#">Samples</a>
SN65220DBVRG4	ACTIVE	SOT-23	DBV	6	3000	Green (RoHS & no Sb/Br)	CU NIPDAU	Level-1-260C-UNLIM	-40 to 85	SADI	<a href="#">Samples</a>
SN65220DBVT	ACTIVE	SOT-23	DBV	6	250	Green (RoHS & no Sb/Br)	CU NIPDAU	Level-1-260C-UNLIM	-40 to 85	SADI	<a href="#">Samples</a>
SN65220DBVTG4	ACTIVE	SOT-23	DBV	6	250	Green (RoHS & no Sb/Br)	CU NIPDAU	Level-1-260C-UNLIM	-40 to 85	SADI	<a href="#">Samples</a>
SN65240P	ACTIVE	PDIP	P	8	50	Pb-Free (RoHS)	CU NIPDAU	N / A for Pkg Type	-40 to 85	SN65240P	<a href="#">Samples</a>
SN65240PE4	ACTIVE	PDIP	P	8	50	Pb-Free (RoHS)	CU NIPDAU	N / A for Pkg Type	-40 to 85	SN65240P	<a href="#">Samples</a>
SN65240PW	ACTIVE	TSSOP	PW	8	150	Green (RoHS & no Sb/Br)	CU NIPDAU	Level-1-260C-UNLIM	-40 to 85	A65240	<a href="#">Samples</a>
SN65240PWG4	ACTIVE	TSSOP	PW	8	150	Green (RoHS & no Sb/Br)	CU NIPDAU	Level-1-260C-UNLIM	-40 to 85	A65240	<a href="#">Samples</a>
SN65240PWR	ACTIVE	TSSOP	PW	8	2000	Green (RoHS & no Sb/Br)	CU NIPDAU	Level-1-260C-UNLIM	-40 to 85	A65240	<a href="#">Samples</a>
SN65240PWG4	ACTIVE	TSSOP	PW	8	2000	Green (RoHS & no Sb/Br)	CU NIPDAU	Level-1-260C-UNLIM	-40 to 85	A65240	<a href="#">Samples</a>
SN75240P	ACTIVE	PDIP	P	8	50	Pb-Free (RoHS)	CU NIPDAU	N / A for Pkg Type	0 to 70	SN75240P	<a href="#">Samples</a>
SN75240PW	ACTIVE	TSSOP	PW	8	150	Green (RoHS & no Sb/Br)	CU NIPDAU	Level-1-260C-UNLIM	0 to 70	A75240	<a href="#">Samples</a>
SN75240PWG4	ACTIVE	TSSOP	PW	8	150	Green (RoHS & no Sb/Br)	CU NIPDAU	Level-1-260C-UNLIM	0 to 70	A75240	<a href="#">Samples</a>
SN75240PWR	ACTIVE	TSSOP	PW	8	2000	Green (RoHS & no Sb/Br)	CU NIPDAU	Level-1-260C-UNLIM	0 to 70	A75240	<a href="#">Samples</a>
SN75240PWG4	ACTIVE	TSSOP	PW	8	2000	Green (RoHS & no Sb/Br)	CU NIPDAU	Level-1-260C-UNLIM	0 to 70	A75240	<a href="#">Samples</a>

(1) The marketing status values are defined as follows:

**ACTIVE:** Product device recommended for new designs.

**LIFEBUY:** TI has announced that the device will be discontinued, and a lifetime-buy period is in effect.

**NRND:** Not recommended for new designs. Device is in production to support existing customers, but TI does not recommend using this part in a new design.

---

**PREVIEW:** Device has been announced but is not in production. Samples may or may not be available.

**OBSOLETE:** TI has discontinued the production of the device.

(2) Eco Plan - The planned eco-friendly classification: Pb-Free (RoHS), Pb-Free (RoHS Exempt), or Green (RoHS & no Sb/Br) - please check <http://www.ti.com/productcontent> for the latest availability information and additional product content details.

**TBD:** The Pb-Free/Green conversion plan has not been defined.

**Pb-Free (RoHS):** TI's terms "Lead-Free" or "Pb-Free" mean semiconductor products that are compatible with the current RoHS requirements for all 6 substances, including the requirement that lead not exceed 0.1% by weight in homogeneous materials. Where designed to be soldered at high temperatures, TI Pb-Free products are suitable for use in specified lead-free processes.

**Pb-Free (RoHS Exempt):** This component has a RoHS exemption for either 1) lead-based flip-chip solder bumps used between the die and package, or 2) lead-based die adhesive used between the die and leadframe. The component is otherwise considered Pb-Free (RoHS compatible) as defined above.

**Green (RoHS & no Sb/Br):** TI defines "Green" to mean Pb-Free (RoHS compatible), and free of Bromine (Br) and Antimony (Sb) based flame retardants (Br or Sb do not exceed 0.1% by weight in homogeneous material)

(3) MSL, Peak Temp. - The Moisture Sensitivity Level rating according to the JEDEC industry standard classifications, and peak solder temperature.

(4) There may be additional marking, which relates to the logo, the lot trace code information, or the environmental category on the device.

(5) Multiple Device Markings will be inside parentheses. Only one Device Marking contained in parentheses and separated by a "~" will appear on a device. If a line is indented then it is a continuation of the previous line and the two combined represent the entire Device Marking for that device.

(6) Lead/Ball Finish - Orderable Devices may have multiple material finish options. Finish options are separated by a vertical ruled line. Lead/Ball Finish values may wrap to two lines if the finish value exceeds the maximum column width.

**Important Information and Disclaimer:** The information provided on this page represents TI's knowledge and belief as of the date that it is provided. TI bases its knowledge and belief on information provided by third parties, and makes no representation or warranty as to the accuracy of such information. Efforts are underway to better integrate information from third parties. TI has taken and continues to take reasonable steps to provide representative and accurate information but may not have conducted destructive testing or chemical analysis on incoming materials and chemicals. TI and TI suppliers consider certain information to be proprietary, and thus CAS numbers and other limited information may not be available for release.

In no event shall TI's liability arising out of such information exceed the total purchase price of the TI part(s) at issue in this document sold by TI to Customer on an annual basis.

**OTHER QUALIFIED VERSIONS OF SN65220 :**

- Automotive: [SN65220-Q1](#)

NOTE: Qualified Version Definitions:

- Automotive - Q100 devices qualified for high-reliability automotive applications targeting zero defects

**TAPE AND REEL INFORMATION**

**QUADRANT ASSIGNMENTS FOR PIN 1 ORIENTATION IN TAPE**

\*All dimensions are nominal

Device	Package Type	Package Drawing	Pins	SPQ	Reel Diameter (mm)	Reel Width W1 (mm)	A0 (mm)	B0 (mm)	K0 (mm)	P1 (mm)	W (mm)	Pin1 Quadrant
SN65220DBVR	SOT-23	DBV	6	3000	178.0	9.0	3.23	3.17	1.37	4.0	8.0	Q3
SN65220DBVT	SOT-23	DBV	6	250	178.0	9.0	3.23	3.17	1.37	4.0	8.0	Q3
SN65240PWR	TSSOP	PW	8	2000	330.0	12.4	7.0	3.6	1.6	8.0	12.0	Q1
SN75240PWR	TSSOP	PW	8	2000	330.0	12.4	7.0	3.6	1.6	8.0	12.0	Q1

**TAPE AND REEL BOX DIMENSIONS**



\*All dimensions are nominal

Device	Package Type	Package Drawing	Pins	SPQ	Length (mm)	Width (mm)	Height (mm)
SN65220DBVR	SOT-23	DBV	6	3000	180.0	180.0	18.0
SN65220DBVT	SOT-23	DBV	6	250	180.0	180.0	18.0
SN65240PWR	TSSOP	PW	8	2000	367.0	367.0	35.0
SN75240PWR	TSSOP	PW	8	2000	367.0	367.0	35.0

# MECHANICAL DATA

DBV (R-PDSO-G6)

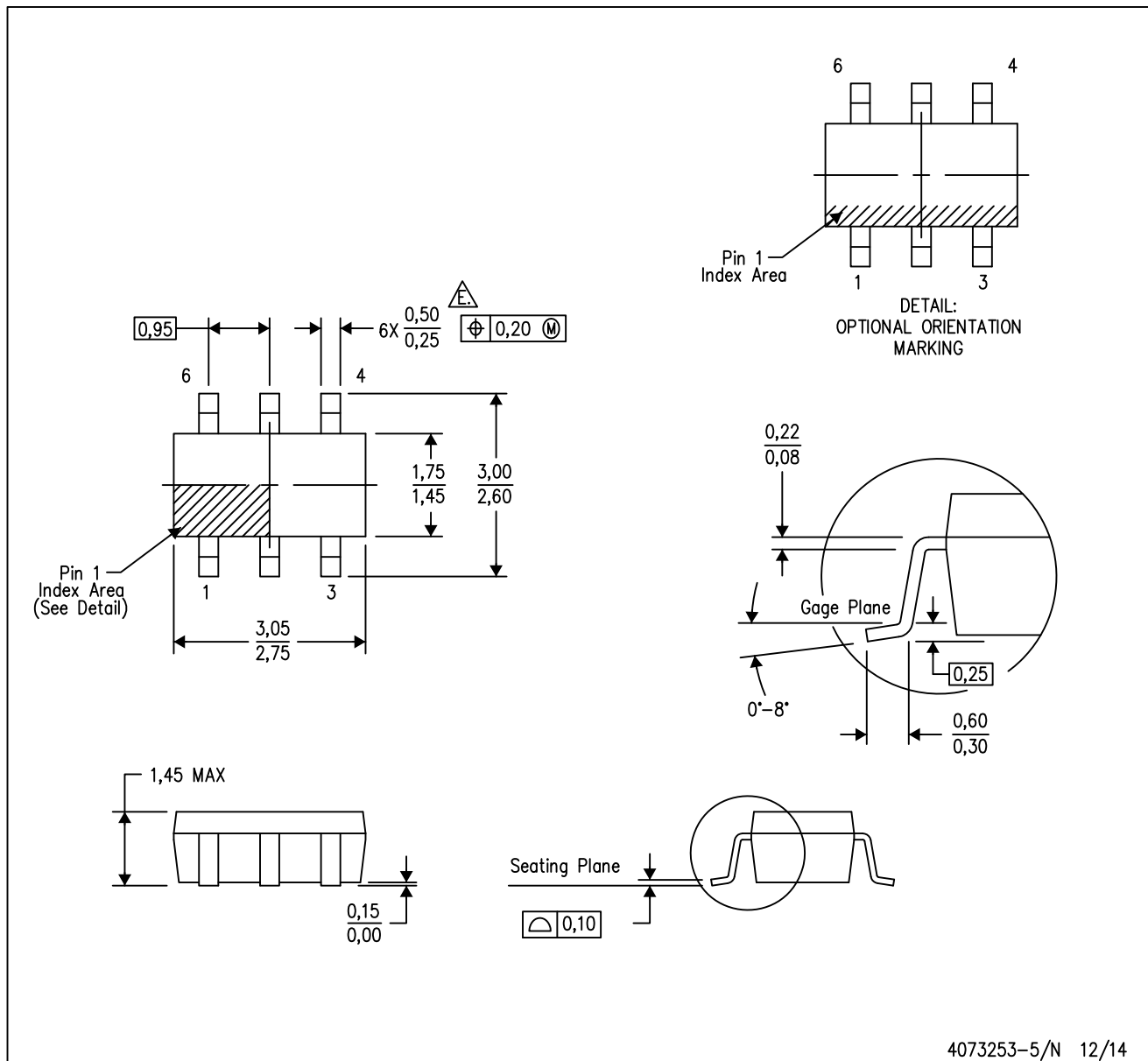
PLASTIC SMALL-OUTLINE PACKAGE



- NOTES:
- All linear dimensions are in millimeters.
  - This drawing is subject to change without notice.
  - Body dimensions do not include mold flash or protrusion. Mold flash and protrusion shall not exceed 0.15 per side.
  - Leads 1,2,3 may be wider than leads 4,5,6 for package orientation.
- Falls within JEDEC MO-178 Variation AB, except minimum lead width.

DBV (R-PDSO-G6)

PLASTIC SMALL OUTLINE

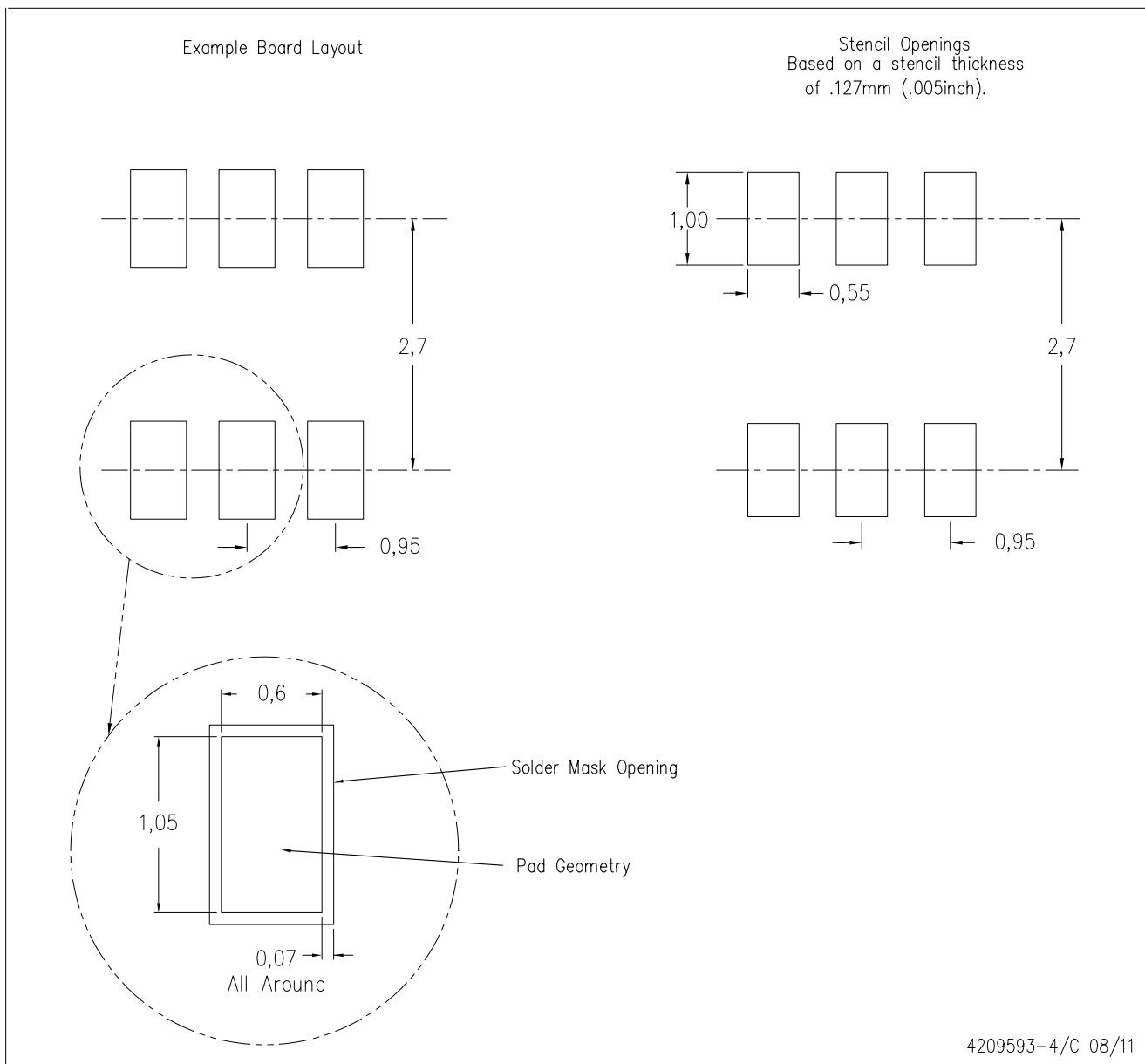

- NOTES:
- A. All linear dimensions are in millimeters.
  - B. This drawing is subject to change without notice.
  - C. Customers should place a note on the circuit board fabrication drawing not to alter the center solder mask defined pad.
  - D. Publication IPC-7351 is recommended for alternate designs.
  - E. Laser cutting apertures with trapezoidal walls and also rounding corners will offer better paste release. Customers should contact their board assembly site for stencil design recommendations. Example stencil design based on a 50% volumetric metal load solder paste. Refer to IPC-7525 for other stencil recommendations.

YZB (S-XBGA-N4)

DIE-SIZE BALL GRID ARRAY

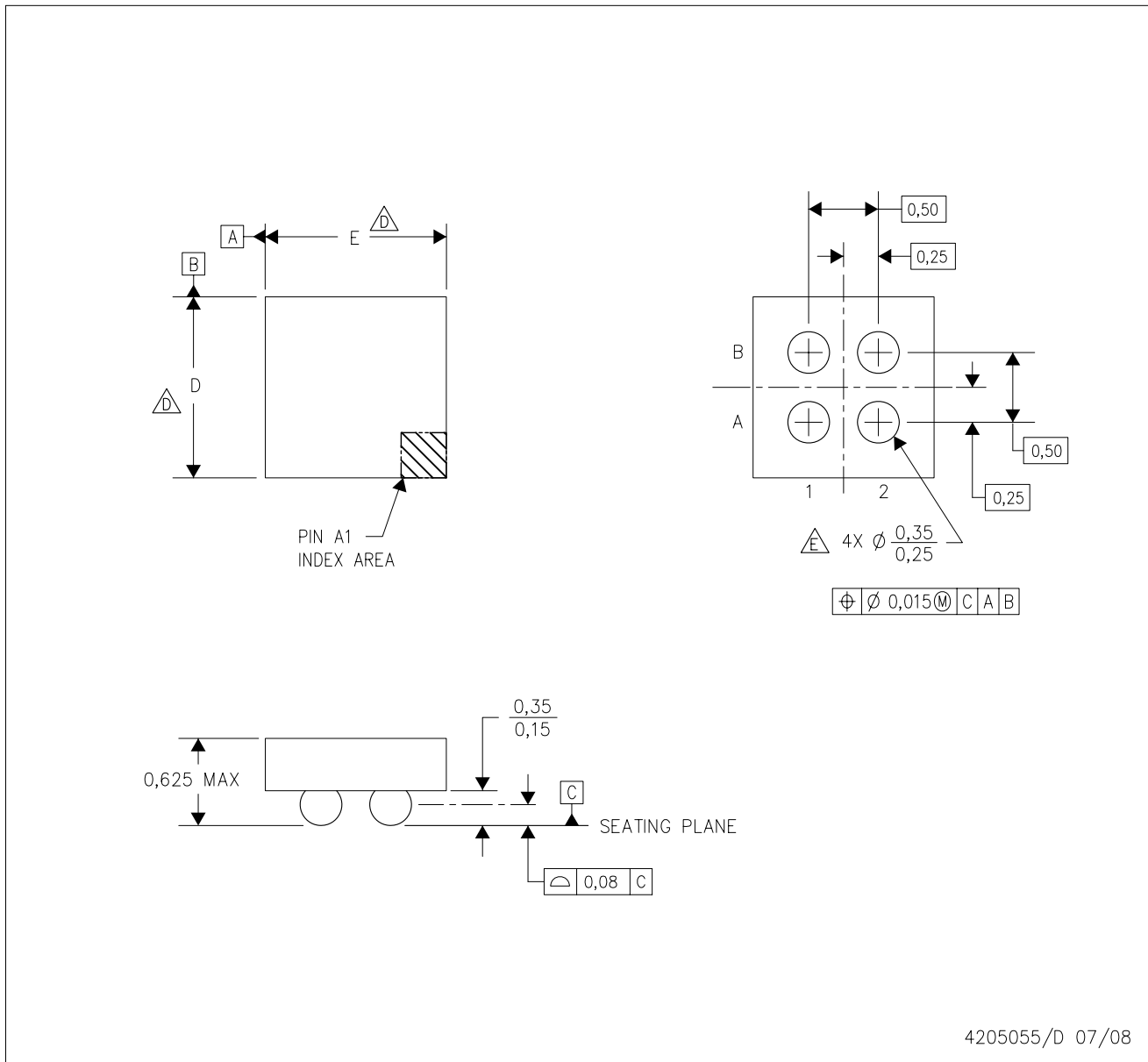

- NOTES:
- A. All linear dimensions are in millimeters.
  - B. This drawing is subject to change without notice.
  - C. NanoFree™ package configuration.
  - $\triangle D$  Devices in YZB package can have dimension D ranging from 0.94 to 1.65 mm and dimension E ranging from 0.94 to 1.65 mm. To determine the exact package size of a particular device, refer to the device datasheet or contact a local TI representative.
  - E. Reference Product Data Sheet for array population.  
2 x 2 matrix pattern is shown for illustration only.
  - F. This package contains lead-free balls.  
Refer to YEB (Drawing #4204178) for tin-lead (SnPb) balls.

P (R-PDIP-T8)

PLASTIC DUAL-IN-LINE PACKAGE



- NOTES:
- A. All linear dimensions are in inches (millimeters).
  - B. This drawing is subject to change without notice.
  - C. Falls within JEDEC MS-001 variation BA.

PW0008A



# PACKAGE OUTLINE

## TSSOP - 1.2 mm max height

SMALL OUTLINE PACKAGE

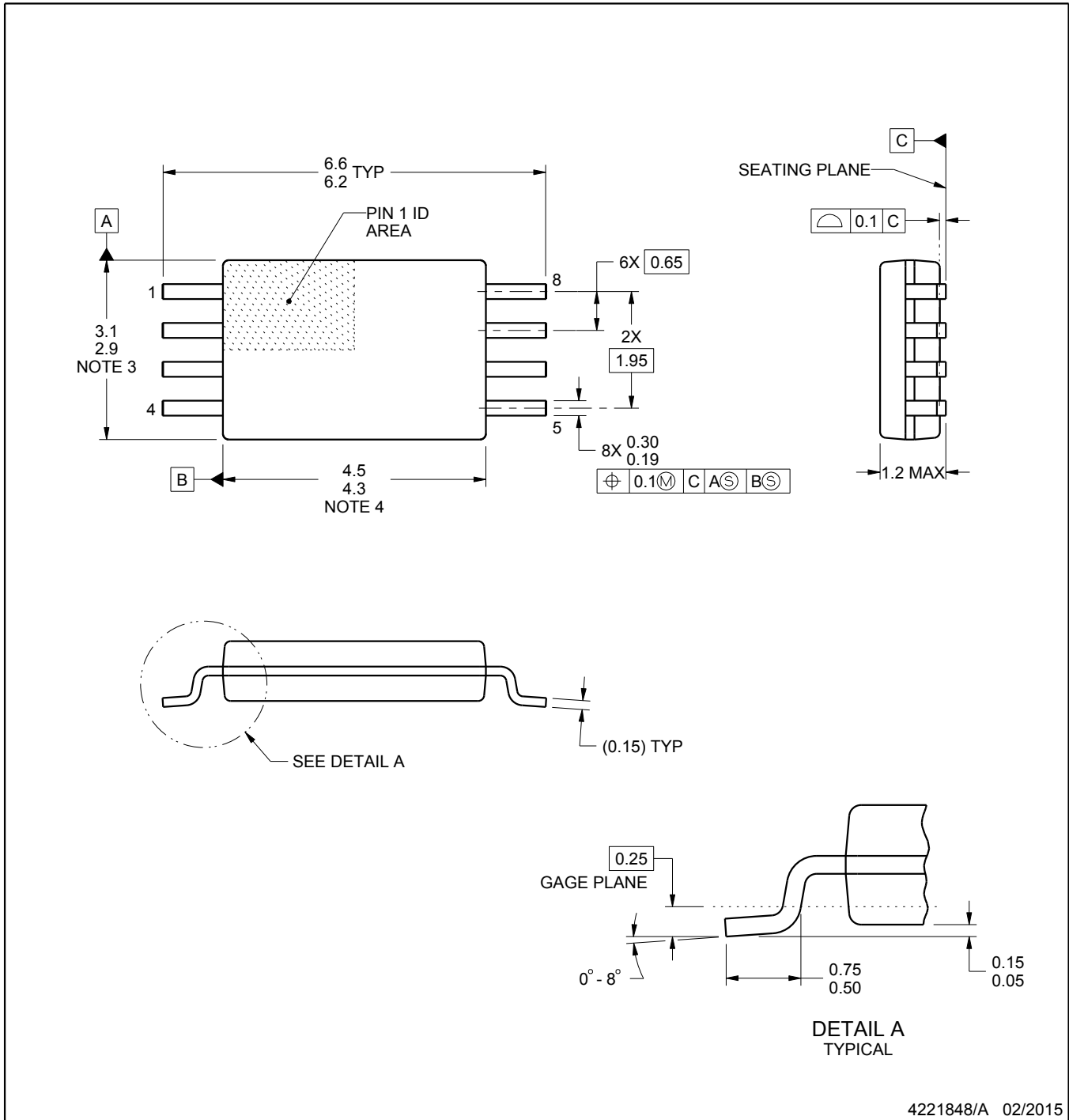

4221848/A 02/2015

### NOTES:

- All linear dimensions are in millimeters. Any dimensions in parenthesis are for reference only. Dimensioning and tolerancing per ASME Y14.5M.
- This drawing is subject to change without notice.
- This dimension does not include mold flash, protrusions, or gate burrs. Mold flash, protrusions, or gate burrs shall not exceed 0.15 mm per side.
- This dimension does not include interlead flash. Interlead flash shall not exceed 0.25 mm per side.
- Reference JEDEC registration MO-153, variation AA.

# EXAMPLE BOARD LAYOUT

PW0008A

TSSOP - 1.2 mm max height

SMALL OUTLINE PACKAGE

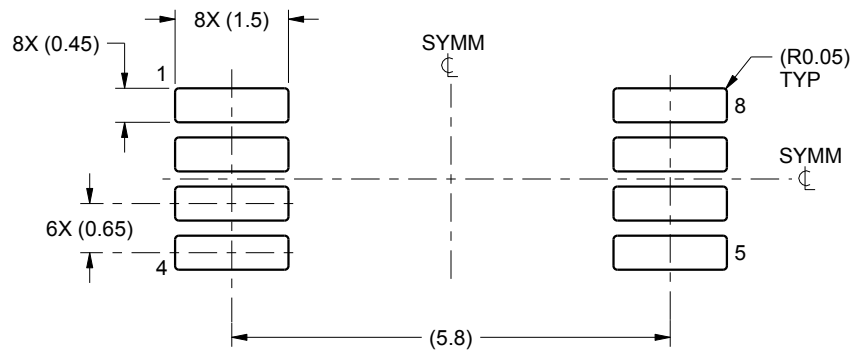

LAND PATTERN EXAMPLE  
SCALE:10X

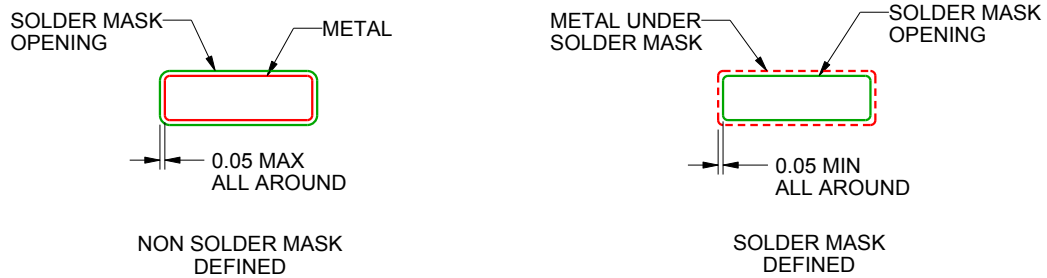

SOLDER MASK DETAILS  
NOT TO SCALE

4221848/A 02/2015

NOTES: (continued)

- 6. Publication IPC-7351 may have alternate designs.
- 7. Solder mask tolerances between and around signal pads can vary based on board fabrication site.

# EXAMPLE STENCIL DESIGN

PW0008A

TSSOP - 1.2 mm max height

SMALL OUTLINE PACKAGE

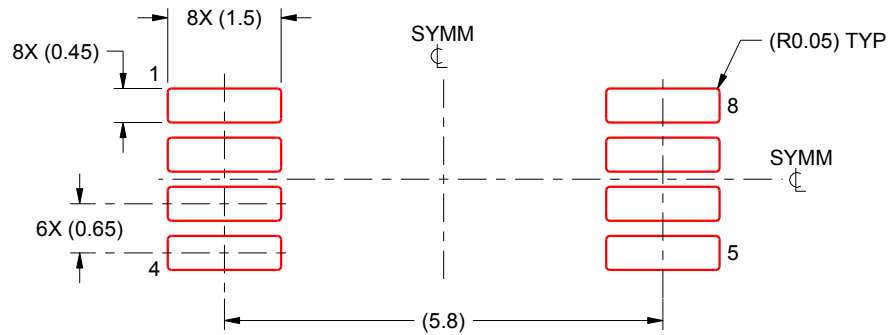

SOLDER PASTE EXAMPLE  
BASED ON 0.125 mm THICK STENCIL  
SCALE:10X

4221848/A 02/2015

NOTES: (continued)

8. Laser cutting apertures with trapezoidal walls and rounded corners may offer better paste release. IPC-7525 may have alternate design recommendations.
9. Board assembly site may have different recommendations for stencil design.

## IMPORTANT NOTICE

Texas Instruments Incorporated (TI) reserves the right to make corrections, enhancements, improvements and other changes to its semiconductor products and services per JESD46, latest issue, and to discontinue any product or service per JESD48, latest issue. Buyers should obtain the latest relevant information before placing orders and should verify that such information is current and complete.

TI's published terms of sale for semiconductor products (<http://www.ti.com/sc/docs/stdterms.htm>) apply to the sale of packaged integrated circuit products that TI has qualified and released to market. Additional terms may apply to the use or sale of other types of TI products and services.

Reproduction of significant portions of TI information in TI data sheets is permissible only if reproduction is without alteration and is accompanied by all associated warranties, conditions, limitations, and notices. TI is not responsible or liable for such reproduced documentation. Information of third parties may be subject to additional restrictions. Resale of TI products or services with statements different from or beyond the parameters stated by TI for that product or service voids all express and any implied warranties for the associated TI product or service and is an unfair and deceptive business practice. TI is not responsible or liable for any such statements.

Buyers and others who are developing systems that incorporate TI products (collectively, "Designers") understand and agree that Designers remain responsible for using their independent analysis, evaluation and judgment in designing their applications and that Designers have full and exclusive responsibility to assure the safety of Designers' applications and compliance of their applications (and of all TI products used in or for Designers' applications) with all applicable regulations, laws and other applicable requirements. Designer represents that, with respect to their applications, Designer has all the necessary expertise to create and implement safeguards that (1) anticipate dangerous consequences of failures, (2) monitor failures and their consequences, and (3) lessen the likelihood of failures that might cause harm and take appropriate actions. Designer agrees that prior to using or distributing any applications that include TI products, Designer will thoroughly test such applications and the functionality of such TI products as used in such applications.

TI's provision of technical, application or other design advice, quality characterization, reliability data or other services or information, including, but not limited to, reference designs and materials relating to evaluation modules, (collectively, "TI Resources") are intended to assist designers who are developing applications that incorporate TI products; by downloading, accessing or using TI Resources in any way, Designer (individually or, if Designer is acting on behalf of a company, Designer's company) agrees to use any particular TI Resource solely for this purpose and subject to the terms of this Notice.

TI's provision of TI Resources does not expand or otherwise alter TI's applicable published warranties or warranty disclaimers for TI products, and no additional obligations or liabilities arise from TI providing such TI Resources. TI reserves the right to make corrections, enhancements, improvements and other changes to its TI Resources. TI has not conducted any testing other than that specifically described in the published documentation for a particular TI Resource.

Designer is authorized to use, copy and modify any individual TI Resource only in connection with the development of applications that include the TI product(s) identified in such TI Resource. NO OTHER LICENSE, EXPRESS OR IMPLIED, BY ESTOPPEL OR OTHERWISE TO ANY OTHER TI INTELLECTUAL PROPERTY RIGHT, AND NO LICENSE TO ANY TECHNOLOGY OR INTELLECTUAL PROPERTY RIGHT OF TI OR ANY THIRD PARTY IS GRANTED HEREIN, including but not limited to any patent right, copyright, mask work right, or other intellectual property right relating to any combination, machine, or process in which TI products or services are used. Information regarding or referencing third-party products or services does not constitute a license to use such products or services, or a warranty or endorsement thereof. Use of TI Resources may require a license from a third party under the patents or other intellectual property of the third party, or a license from TI under the patents or other intellectual property of TI.

TI RESOURCES ARE PROVIDED "AS IS" AND WITH ALL FAULTS. TI DISCLAIMS ALL OTHER WARRANTIES OR REPRESENTATIONS, EXPRESS OR IMPLIED, REGARDING RESOURCES OR USE THEREOF, INCLUDING BUT NOT LIMITED TO ACCURACY OR COMPLETENESS, TITLE, ANY EPIDEMIC FAILURE WARRANTY AND ANY IMPLIED WARRANTIES OF MERCHANTABILITY, FITNESS FOR A PARTICULAR PURPOSE, AND NON-INFRINGEMENT OF ANY THIRD PARTY INTELLECTUAL PROPERTY RIGHTS. TI SHALL NOT BE LIABLE FOR AND SHALL NOT DEFEND OR INDEMNIFY DESIGNER AGAINST ANY CLAIM, INCLUDING BUT NOT LIMITED TO ANY INFRINGEMENT CLAIM THAT RELATES TO OR IS BASED ON ANY COMBINATION OF PRODUCTS EVEN IF DESCRIBED IN TI RESOURCES OR OTHERWISE. IN NO EVENT SHALL TI BE LIABLE FOR ANY ACTUAL, DIRECT, SPECIAL, COLLATERAL, INDIRECT, PUNITIVE, INCIDENTAL, CONSEQUENTIAL OR EXEMPLARY DAMAGES IN CONNECTION WITH OR ARISING OUT OF TI RESOURCES OR USE THEREOF, AND REGARDLESS OF WHETHER TI HAS BEEN ADVISED OF THE POSSIBILITY OF SUCH DAMAGES.

Unless TI has explicitly designated an individual product as meeting the requirements of a particular industry standard (e.g., ISO/TS 16949 and ISO 26262), TI is not responsible for any failure to meet such industry standard requirements.

Where TI specifically promotes products as facilitating functional safety or as compliant with industry functional safety standards, such products are intended to help enable customers to design and create their own applications that meet applicable functional safety standards and requirements. Using products in an application does not by itself establish any safety features in the application. Designers must ensure compliance with safety-related requirements and standards applicable to their applications. Designer may not use any TI products in life-critical medical equipment unless authorized officers of the parties have executed a special contract specifically governing such use. Life-critical medical equipment is medical equipment where failure of such equipment would cause serious bodily injury or death (e.g., life support, pacemakers, defibrillators, heart pumps, neurostimulators, and implantables). Such equipment includes, without limitation, all medical devices identified by the U.S. Food and Drug Administration as Class III devices and equivalent classifications outside the U.S.

TI may expressly designate certain products as completing a particular qualification (e.g., Q100, Military Grade, or Enhanced Product). Designers agree that it has the necessary expertise to select the product with the appropriate qualification designation for their applications and that proper product selection is at Designers' own risk. Designers are solely responsible for compliance with all legal and regulatory requirements in connection with such selection.

Designer will fully indemnify TI and its representatives against any damages, costs, losses, and/or liabilities arising out of Designer's non-compliance with the terms and provisions of this Notice.