

SN64BCT25245

25-Ω OCTAL BUS TRANSCEIVER

SCBS060A – JUNE 1990 – REVISED DECEMBER 1993

- State-of-the-Art BiCMOS Design Significantly Reduces I_{CCZ}
- Designed to Facilitate Incident-Wave Switching for Line Impedances of 25 Ω or Greater
- Distributed V_{CC} and GND Pins Minimize Noise Generated by the Simultaneous Switching of Outputs
- Data Flow-Through Pinout (All Inputs on Opposite Side From Outputs)
- High-Impedance State During Power Up and Power Down
- ESD Protection Exceeds 2000 V Per MIL-STD-883C, Method 3015
- Package Options Include Plastic Small-Outline (DW) Packages and Standard Plastic 300-mil DIPs (NT)

DW OR NT PACKAGE
(TOP VIEW)

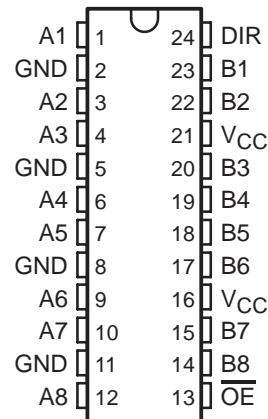

description

The SN64BCT25245 is a 25-Ω octal bus transceiver designed for asynchronous communication between data buses. It improves both the performance and density of 3-state memory address drivers, clock drivers, and bus-oriented transceivers.

The device allows data transmission from the A bus to the B bus or from the B bus to the A bus depending upon the logic level at the direction-control (DIR) input. The output-enable (\overline{OE}) input can disable the device so that both buses are effectively isolated.

This transceiver is capable of sinking 188-mA I_{OL} , which facilitates switching 25-Ω transmission lines on the incident wave. The distributed V_{CC} and GND pins minimize switching noise for more reliable system operation.

The outputs are in a high-impedance state during power up and power down while the supply voltage is less than approximately 3 V.

The SN64BCT25245 is characterized for operation from -40°C to 85°C and 0°C to 70°C.

FUNCTION TABLE

INPUTS		OPERATION
\overline{OE}	DIR	
L	L	B data to A bus
L	H	A data to B bus
H	X	Isolation

SN64BCT25245

25-Ω OCTAL BUS TRANSCEIVER

SCBS060A – JUNE 1990 – REVISED DECEMBER 1993

logic symbol†

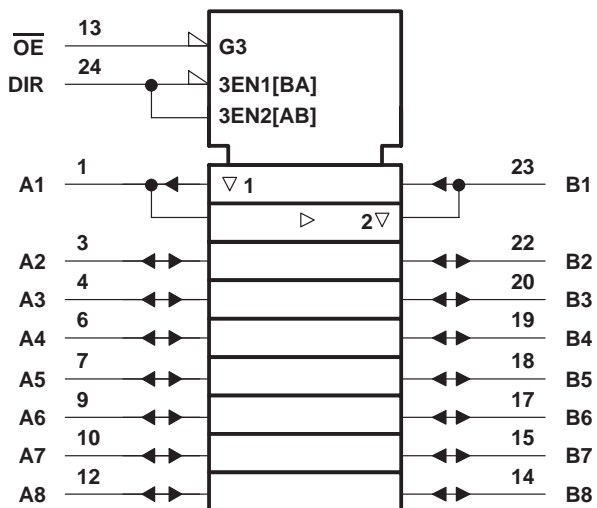

logic diagram (positive logic)

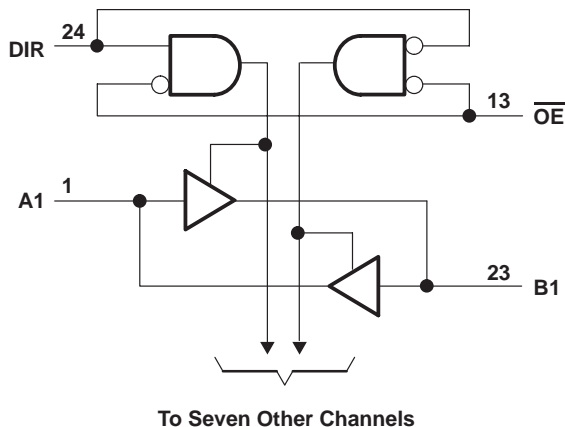

† This symbol is in accordance with ANSI/IEEE Std 91-1984 and IEC Publication 617-12.

absolute maximum ratings over operating free-air temperature range (unless otherwise noted)‡

Supply voltage range, V_{CC}	-0.5 V to 7 V
Input voltage range, V_I (see Note 1): Control inputs	-0.5 V to 7 V
I/O ports	-0.5 V to 5.5 V
Voltage range applied to any output in the disabled or power-off state, V_O	-0.5 V to 7 V
Voltage range applied to any output in the high state, V_O (B port)	-0.5 V to V_{CC}
Input clamp current, I_{IK}	-30 mA
Current into any output in the low state, I_O : A port	376 mA
B port	48 mA
Operating free-air temperature range	-40°C to 85°C
Storage temperature range	-65°C to 150°C

‡ Stresses beyond those listed under "absolute maximum ratings" may cause permanent damage to the device. These are stress ratings only, and functional operation of the device at these or any other conditions beyond those indicated under "recommended operating conditions" is not implied. Exposure to absolute-maximum-rated conditions for extended periods may affect device reliability.

NOTE 1: The input and output negative-voltage ratings may be exceeded if the input and output clamp-current ratings are observed.

recommended operating conditions

		MIN	NOM	MAX	UNIT
V_{CC}	Supply voltage	4.5	5	5.5	V
V_{IH}	High-level input voltage	2			V
V_{IL}	Low-level input voltage			0.8	V
I_{IK}	Input clamp current			-18	mA
I_{OH}	High-level output current	A port		-80	mA
		B port		-3	
I_{OL}	Low-level output current	A port		188	mA
		B port		24	
T_A	Operating free-air temperature	-40		85	°C

electrical characteristics over recommended operating free-air temperature range (unless otherwise noted)

PARAMETER		TEST CONDITIONS		MIN	TYP†	MAX	UNIT
V _{IK}		V _{CC} = 4.5 V,	I _I = -18 mA			-1.2	V
V _{OH}	A port	V _{CC} = 4.75 V,	I _{OH} = -3 mA	2.7			V
		V _{CC} = 4.5 V,	I _{OH} = -80 mA	2			
	B port	V _{CC} = 4.5 V,	I _{OH} = -3 mA	2.4	3.3		
V _{OL}	A port	V _{CC} = 4.5 V	I _{OL} = 94 mA		0.42	0.55	V
			I _{OL} = 188 mA			0.7	
	B port	V _{CC} = 4.5 V,	I _{OL} = 24 mA		0.35	0.5	
I _{OZ}	V _{CC} = 0 to 2.3 V (power up)		V _O = 2.7 V	$\overline{\text{OE}}$ at 0.8 V		70	μA
			V _O = 0.5 V			-0.6	mA
	V _{CC} = 1.8 V to 0 (power down)		V _O = 2.7 V	$\overline{\text{OE}}$ at 0.8 V		70	μA
			V _O = 0.5 V			-0.6	mA
I _I	A and B ports	V _{CC} = 0 to 5.5 V,	V _I = 5.5 V			0.25	mA
	DIR and $\overline{\text{OE}}$					0.1	
I _{IH} ‡	A and B ports	V _{CC} = 5.5 V,	V _I = 2.7 V			70	μA
	DIR and $\overline{\text{OE}}$					20	
I _{IL} ‡	A and B ports	V _{CC} = 5.5 V,	V _I = 0.5 V			-0.6	mA
	DIR and $\overline{\text{OE}}$						
I _{OS} §	B port¶	V _{CC} = 5.5 V,	V _O = 0	-60		-150	mA
I _{CCL}	A to B port	V _{CC} = 5.5 V			48	60	mA
	B to A port				95	125	
I _{CCH}	A to B port	V _{CC} = 5.5 V			36	46	mA
	B to A port				63	80	
I _{CCZ}		V _{CC} = 5.5 V			12	16	mA
C _i	$\overline{\text{OE}}$ and DIR	V _{CC} = 5.5 V,	V _I = 2.5 V to 0.5 V			8	pF
C _{io}	A port	V _{CC} = 5.5 V,	V _I = 2.5 V to 0.5 V			18	pF
	B port					8	

† All typical values are at V_{CC} = 5 V, T_A = 25°C.

‡ For I/O ports, the parameters I_{IH} and I_{IL} include the off-state outputs current.

§ Not more than one output should be tested at a time, and the duration of the test should not exceed one second.

¶ Testing for this parameter on the A port is not recommended.

SN64BCT25245

25-Ω OCTAL BUS TRANSCEIVER

SCBS060A – JUNE 1990 – REVISED DECEMBER 1993

switching characteristics (see Note 2)

PARAMETER	FROM (INPUT)	TO (OUTPUT)	V _{CC} = 5 V, C _L = 50 pF, R ₁ = 500 Ω, R ₂ = 500 Ω, T _A = 25°C			V _{CC} = 4.5 V to 5.5 V, C _L = 50 pF, R ₁ = 500 Ω, R ₂ = 500 Ω				UNIT
						T _A = -40°C to 85°C		T _A = 0°C to 70°C		
			MIN	TYP	MAX	MIN	MAX	MIN	MAX	
t _{PLH}	A	B	1.2	3.3	5.1	1.2	5.7	1.2	5.7	ns
t _{PHL}			1.9	4.3	6.7	1.9	7.3	1.9	7.2	
t _{PLH}	B	A	1.2	3.3	4.8	1.2	5.5	1.2	5.5	ns
t _{PHL}			2.1	4	5.6	2.1	6.3	2.1	6.2	
t _{PZH}	\overline{OE}	A	3.7	6.3	8.4	3.7	9.7	3.7	9.6	ns
t _{PZL}			4.5	7.4	9.2	4.5	10.6	4.5	10.3	
t _{PHZ}	\overline{OE}	A	1.8	3.7	5.5	1.8	6.2	1.8	6.2	ns
t _{PLZ}			3.3	5.1	7.2	3.3	8.8	3.3	8.3	
t _{PZH}	\overline{OE}	B	3.4	5.7	7.9	3.4	8.9	3.4	8.9	ns
t _{PZL}			4.3	6.6	8.7	4.3	9.9	4.3	9.7	
t _{PHZ}	\overline{OE}	B	2.7	4.5	6.3	2.7	6.9	2.7	6.9	ns
t _{PLZ}			1.7	4.5	6.8	1.7	7.7	1.7	7.5	

NOTE 2: Load circuits and voltage waveforms are shown in Section 1.



PACKAGING INFORMATION

Orderable Device	Status ⁽¹⁾	Package Type	Package Drawing	Pins	Package Qty	Eco Plan ⁽²⁾	Lead/ Ball Finish	MSL Peak Temp ⁽³⁾	Samples (Requires Login)
SN64BCT25245DW	ACTIVE	SOIC	DW	24	25	Green (RoHS & no Sb/Br)	CU NIPDAU	Level-1-260C-UNLIM	
SN64BCT25245DWE4	ACTIVE	SOIC	DW	24	25	Green (RoHS & no Sb/Br)	CU NIPDAU	Level-1-260C-UNLIM	
SN64BCT25245DWG4	ACTIVE	SOIC	DW	24	25	Green (RoHS & no Sb/Br)	CU NIPDAU	Level-1-260C-UNLIM	
SN64BCT25245DWRE4	ACTIVE	SOIC	DW	24		TBD	Call TI	Call TI	
SN64BCT25245DWRG4	ACTIVE	SOIC	DW	24		TBD	Call TI	Call TI	

⁽¹⁾ The marketing status values are defined as follows:

ACTIVE: Product device recommended for new designs.

LIFEBUY: TI has announced that the device will be discontinued, and a lifetime-buy period is in effect.

NRND: Not recommended for new designs. Device is in production to support existing customers, but TI does not recommend using this part in a new design.

PREVIEW: Device has been announced but is not in production. Samples may or may not be available.

OBSOLETE: TI has discontinued the production of the device.

⁽²⁾ Eco Plan - The planned eco-friendly classification: Pb-Free (RoHS), Pb-Free (RoHS Exempt), or Green (RoHS & no Sb/Br) - please check <http://www.ti.com/productcontent> for the latest availability information and additional product content details.

TBD: The Pb-Free/Green conversion plan has not been defined.

Pb-Free (RoHS): TI's terms "Lead-Free" or "Pb-Free" mean semiconductor products that are compatible with the current RoHS requirements for all 6 substances, including the requirement that lead not exceed 0.1% by weight in homogeneous materials. Where designed to be soldered at high temperatures, TI Pb-Free products are suitable for use in specified lead-free processes.

Pb-Free (RoHS Exempt): This component has a RoHS exemption for either 1) lead-based flip-chip solder bumps used between the die and package, or 2) lead-based die adhesive used between the die and leadframe. The component is otherwise considered Pb-Free (RoHS compatible) as defined above.

Green (RoHS & no Sb/Br): TI defines "Green" to mean Pb-Free (RoHS compatible), and free of Bromine (Br) and Antimony (Sb) based flame retardants (Br or Sb do not exceed 0.1% by weight in homogeneous material)

⁽³⁾ MSL, Peak Temp. -- The Moisture Sensitivity Level rating according to the JEDEC industry standard classifications, and peak solder temperature.

Important Information and Disclaimer: The information provided on this page represents TI's knowledge and belief as of the date that it is provided. TI bases its knowledge and belief on information provided by third parties, and makes no representation or warranty as to the accuracy of such information. Efforts are underway to better integrate information from third parties. TI has taken and continues to take reasonable steps to provide representative and accurate information but may not have conducted destructive testing or chemical analysis on incoming materials and chemicals. TI and TI suppliers consider certain information to be proprietary, and thus CAS numbers and other limited information may not be available for release.

In no event shall TI's liability arising out of such information exceed the total purchase price of the TI part(s) at issue in this document sold by TI to Customer on an annual basis.

DW (R-PDSO-G24)

PLASTIC SMALL OUTLINE

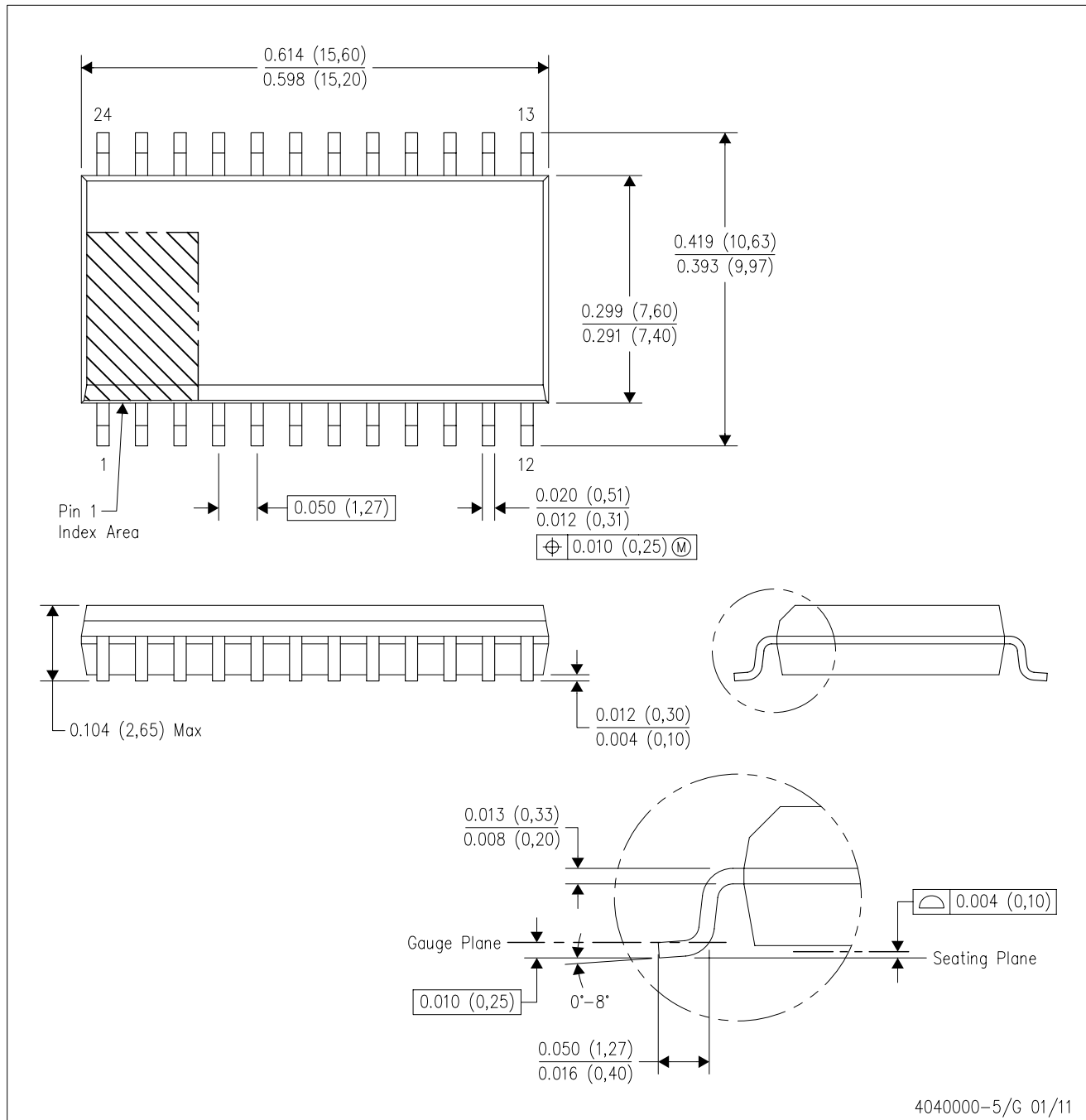

- NOTES:
- All linear dimensions are in inches (millimeters). Dimensioning and tolerancing per ASME Y14.5M-1994.
 - This drawing is subject to change without notice.
 - Body dimensions do not include mold flash or protrusion not to exceed 0.006 (0,15).
 - Falls within JEDEC MS-013 variation AD.

IMPORTANT NOTICE

Texas Instruments Incorporated and its subsidiaries (TI) reserve the right to make corrections, modifications, enhancements, improvements, and other changes to its products and services at any time and to discontinue any product or service without notice. Customers should obtain the latest relevant information before placing orders and should verify that such information is current and complete. All products are sold subject to TI's terms and conditions of sale supplied at the time of order acknowledgment.

TI warrants performance of its hardware products to the specifications applicable at the time of sale in accordance with TI's standard warranty. Testing and other quality control techniques are used to the extent TI deems necessary to support this warranty. Except where mandated by government requirements, testing of all parameters of each product is not necessarily performed.

TI assumes no liability for applications assistance or customer product design. Customers are responsible for their products and applications using TI components. To minimize the risks associated with customer products and applications, customers should provide adequate design and operating safeguards.

TI does not warrant or represent that any license, either express or implied, is granted under any TI patent right, copyright, mask work right, or other TI intellectual property right relating to any combination, machine, or process in which TI products or services are used. Information published by TI regarding third-party products or services does not constitute a license from TI to use such products or services or a warranty or endorsement thereof. Use of such information may require a license from a third party under the patents or other intellectual property of the third party, or a license from TI under the patents or other intellectual property of TI.

Reproduction of TI information in TI data books or data sheets is permissible only if reproduction is without alteration and is accompanied by all associated warranties, conditions, limitations, and notices. Reproduction of this information with alteration is an unfair and deceptive business practice. TI is not responsible or liable for such altered documentation. Information of third parties may be subject to additional restrictions.

Resale of TI products or services with statements different from or beyond the parameters stated by TI for that product or service voids all express and any implied warranties for the associated TI product or service and is an unfair and deceptive business practice. TI is not responsible or liable for any such statements.

TI products are not authorized for use in safety-critical applications (such as life support) where a failure of the TI product would reasonably be expected to cause severe personal injury or death, unless officers of the parties have executed an agreement specifically governing such use. Buyers represent that they have all necessary expertise in the safety and regulatory ramifications of their applications, and acknowledge and agree that they are solely responsible for all legal, regulatory and safety-related requirements concerning their products and any use of TI products in such safety-critical applications, notwithstanding any applications-related information or support that may be provided by TI. Further, Buyers must fully indemnify TI and its representatives against any damages arising out of the use of TI products in such safety-critical applications.

TI products are neither designed nor intended for use in military/aerospace applications or environments unless the TI products are specifically designated by TI as military-grade or "enhanced plastic." Only products designated by TI as military-grade meet military specifications. Buyers acknowledge and agree that any such use of TI products which TI has not designated as military-grade is solely at the Buyer's risk, and that they are solely responsible for compliance with all legal and regulatory requirements in connection with such use.

TI products are neither designed nor intended for use in automotive applications or environments unless the specific TI products are designated by TI as compliant with ISO/TS 16949 requirements. Buyers acknowledge and agree that, if they use any non-designated products in automotive applications, TI will not be responsible for any failure to meet such requirements.

Following are URLs where you can obtain information on other Texas Instruments products and application solutions:

Products

Audio	www.ti.com/audio
Amplifiers	amplifier.ti.com
Data Converters	dataconverter.ti.com
DLP® Products	www.dlp.com
DSP	dsp.ti.com
Clocks and Timers	www.ti.com/clocks
Interface	interface.ti.com
Logic	logic.ti.com
Power Mgmt	power.ti.com
Microcontrollers	microcontroller.ti.com
RFID	www.ti-rfid.com
RF/IF and ZigBee® Solutions	www.ti.com/lprf

Applications

Communications and Telecom	www.ti.com/communications
Computers and Peripherals	www.ti.com/computers
Consumer Electronics	www.ti.com/consumer-apps
Energy and Lighting	www.ti.com/energy
Industrial	www.ti.com/industrial
Medical	www.ti.com/medical
Security	www.ti.com/security
Space, Avionics and Defense	www.ti.com/space-avionics-defense
Transportation and Automotive	www.ti.com/automotive
Video and Imaging	www.ti.com/video
Wireless	www.ti.com/wireless-apps

TI E2E Community Home Page

e2e.ti.com

Mailing Address: Texas Instruments, Post Office Box 655303, Dallas, Texas 75265
Copyright © 2011, Texas Instruments Incorporated