

SN10KHT5542, SN10KHT5543 OCTAL TTL-TO-ECL TRANSLATORS WITH OUTPUT ENABLE

SDZS001A – D3136, AUGUST 1988 – REVISED DECEMBER 1988

- 10KH Compatible
- ECL and TTL Control Inputs
- P-N-P Inputs Reduce DC Loading
- Flow-Through Architectures Optimizes PCB Layout
- Center Pin VCC, VEE and GND Configurations Minimize High-Speed Switching Noise
- ESD Protection Exceeds 2000 V Per MIL-STD-883C, Method 3015
- Package Options Include "Small Outline" Packages and Standard Plastic 300-mil DIPs

**DW OR NT PACKAGE
(TOP VIEW)**

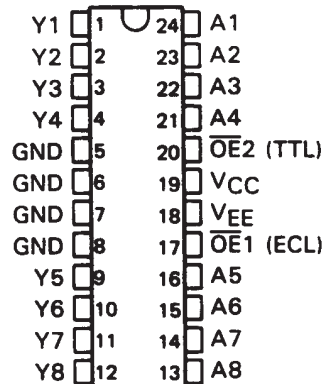

description

These octal TTL-to-ECL translators are designed to provide efficient translation between a TTL signal environment and a 10KH ECL signal environment. The designer has a choice of inverting ('5542) or true ('5543) outputs. Two pins, $\overline{OE1}$ and $\overline{OE2}$, are provided for output enable control. These control inputs are negative ANDed together, with $\overline{OE1}$ being ECL compatible and $\overline{OE2}$ being TTL compatible. This offers the choice of controlling the outputs of the device from either a TTL or ECL signal environment. The outputs, when disabled, go to a normal ECL logic low level.

The SN10KHT5542 and SN10KHT5543 are characterized for operation from 0°C to 75°C.

FUNCTION TABLE

OUTPUT CONTROL		DATA INPUT	OUTPUT	
$\overline{OE1}$	$\overline{OE2}$	A	'5542	'5543
H	X	X	L	L
X	H	X	L	L
L	L	L	H	L
L	L	H	L	H

logic symbols†

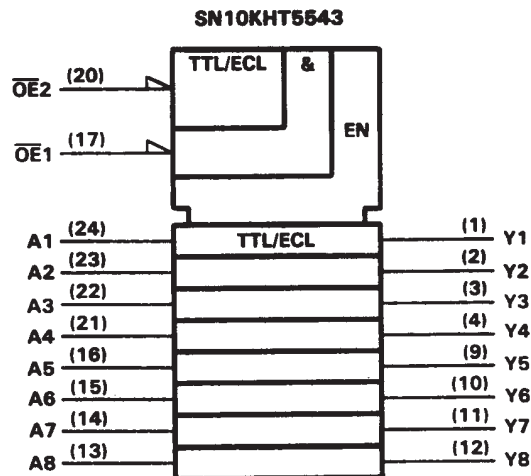
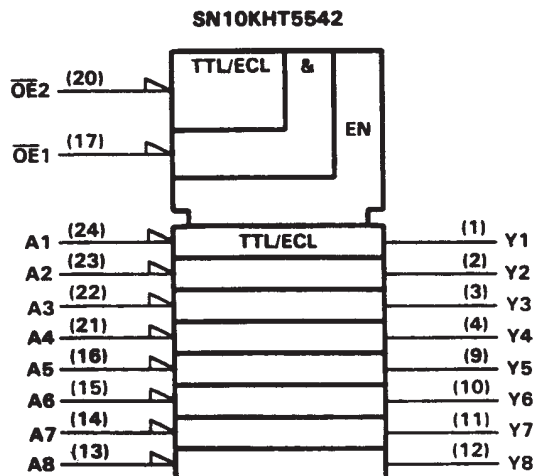

†These symbols are in accordance with ANSI/IEEE Std 91-1984 and IEC Publication 617-12.

SN10KHT5542, SN10KHT5543 OCTAL TTL-TO-ECL TRANSLATORS WITH OUTPUT ENABLE

SDZS001A – D3136, AUGUST 1988 – REVISED DECEMBER 1988

logic diagrams (positive logic)

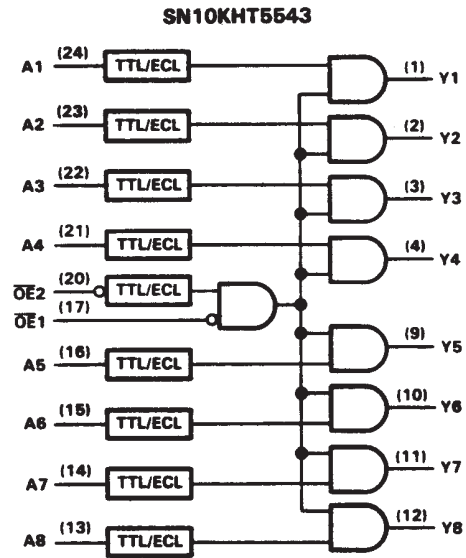
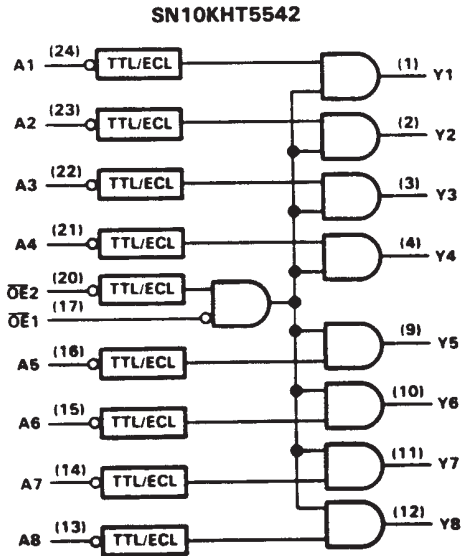

absolute maximum ratings over operating ambient temperature range (unless otherwise noted)[†]

Supply voltage range, V_{CC}	-0.5 V to 7 V
Supply voltage range, V_{EE}	-8 V to 0 V
Input voltage range (TTL) (See Note 1)	-1.2 V to 7 V
Input voltage range (ECL)	V_{EE} to 0 V
Input current range (TTL)	-30 mA to 5 mA
Operating ambient temperature range	0°C to 75°C
Storage temperature range	-65°C to 150°C

[†]Stresses beyond those listed under "absolute maximum ratings" may cause permanent damage to the device. These are stress ratings only and functional operation of the device at these or any other conditions beyond those indicated under "recommended operating conditions" is not implied. Exposure to absolute-maximum-rated conditions for extended periods may affect device reliability.

NOTE 1: The input voltage ratings may be exceeded provided the input current ratings are observed.

recommended operating conditions (see Note 2)

		MIN	NOM	MAX	UNIT	
V_{CC}	TTL supply voltage	4.5	5.0	5.5	V	
V_{EE}	ECL supply voltage	-4.94	-5.2	-5.46	V	
V_{IH}	TTL high-level input voltage	2			V	
V_{IH}	ECL high-level input voltage [‡]	0°C	-1170	-840	mV	
		25°C	-1130	-810		
		75°C	-1070	-735		
V_{IL}	TTL low-level input voltage	0.8			V	
V_{IL}	ECL low-level input voltage [‡]	0°C	-1950	-1480	mV	
		25°C	-1950	-1480		
		75°C	-1950	-1450		
I_{IK}	TTL input clamp current	-18			mA	
T_A	Operating ambient temperature (see Note 3)	0			75	°C

[‡] The algebraic convention, in which the least positive (most negative) value is designated minimum, is used in this data sheet for logic voltage levels and temperature only.

NOTES: 2. If unused, OE1 should be tied directly to -2 V.

3. Each 10KH series circuit has been designed to meet the dc specifications shown in the electrical characteristics table after thermal equilibrium has been established. The circuit is in a test socket or mounted on a printed circuit board, and transverse air flow greater than 500 linear ft/min is maintained.



POST OFFICE BOX 655303 • DALLAS, TEXAS 75265

SN10KHT5542, SN10KHT5543 OCTAL TTL-TO-ECL TRANSLATORS WITH OUTPUT ENABLE

SDZS001A – D3136, AUGUST 1988 – REVISED DECEMBER 1988

electrical characteristics over recommended operating ambient temperature range (unless otherwise noted) (see Note 2)

PARAMETER		TEST CONDITIONS		MIN	TYP†	MAX	UNIT
V_{IK}	A inputs and $\overline{OE}2$	$V_{CC} = 4.5\text{ V}, V_{EE} = -4.94\text{ V}, I_I = -18\text{ mA}$				-1.2	V
I_I	A inputs and $\overline{OE}2$	$V_{CC} = 5.5\text{ V}, V_{EE} = -5.46\text{ V}, V_I = 7\text{ V}$				0.1	mA
I_{IH}	A inputs and $\overline{OE}2$	$V_{CC} = 5.5\text{ V}, V_{EE} = -5.46\text{ V}, V_I = 2.7\text{ V}$				20	μA
	$\overline{OE}1$ only	$V_{CC} = 5.5\text{ V}, V_{EE} = -5.46\text{ V}, V_I = -840\text{ mV}$	0°C		350		
		$V_{CC} = 5.5\text{ V}, V_{EE} = -5.46\text{ V}, V_I = -810\text{ mV}$	25°C		350		
		$V_{CC} = 5.5\text{ V}, V_{EE} = -5.46\text{ V}, V_I = -735\text{ mV}$	75°C		350		
I_{IL}	A inputs and $\overline{OE}2$	$V_{CC} = 5.5\text{ V}, V_{EE} = -5.46\text{ V}, V_I = 0.5\text{ V}$				-500	μA
	$\overline{OE}1$ only	$V_{CC} = 5.5\text{ V}, V_{EE} = -5.46\text{ V}, V_I = -1950\text{ mV}$	0°C	0.5			
			25°C	0.5			
			75°C	0.5			
V_{OH}^\ddagger		$V_{CC} = 4.5\text{ V}, V_{EE} = -5.2\text{ V}, \pm 5\%, \text{ See Note 3}$	0°C	-1020	-840		
			25°C	-980	-810		
			75°C	-920	-735		
V_{OL}^\ddagger		$V_{CC} = 4.5\text{ V}, V_{EE} = -5.2\text{ V}, \pm 5\%, \text{ See Note 3}$	0°C	-1950	-1630		
			25°C	-1950	-1630		
			75°C	-1950	-1600		
I_{CCH}		$V_{CC} = 5.5\text{ V}, V_{EE} = -5.46\text{ V}$			15	22	mA
I_{CCL}		$V_{CC} = 5.5\text{ V}, V_{EE} = -5.46\text{ V}$			17	25	mA
I_{EE}		$V_{CC} = 5.5\text{ V}, V_{EE} = -5.46\text{ V}$			-78	-111	mA
C_i		$V_{CC} = 5\text{ V}, V_{EE} = -5.2\text{ V}, f = 10\text{ MHz}$			5		pF

switching characteristics over recommended ranges of operating ambient temperature and supply voltage (unless otherwise noted) (see Note 4)

PARAMETER	FROM (INPUT)	TO (OUTPUT)	MIN	TYP†	MAX	UNIT
t_{PLH}	Any A	Y	0.1	1.7	3.7	ns
t_{PHL}			0.1	1.6	3.3	
t_{PLH}	$\overline{OE}1$ (ECL)	Y	0.8	2.8	5	ns
t_{PHL}			0.4	2.3	4.5	
t_{PLH}	$\overline{OE}2$ (TTL)	Y	0.8	3	5.3	ns
t_{PHL}			0.6	2.5	4.7	
t_r		Y	1.5			ns
t_f			1.5			

† All typical values are at $V_{CC} = 5\text{ V}, V_{EE} = -5.2\text{ V}, T_A = 25^\circ\text{C}$.

‡ The algebraic convention, in which the least positive (most negative) value is designated minimum, is used in this data sheet for logic voltage levels and temperature only.

- NOTES: 2. Each 10KH series circuit has been designed to meet the dc specifications shown in the electrical characteristics table after thermal equilibrium has been established. The circuit is in a test socket or mounted on a printed circuit board and transverse air flow greater than 500 linear ft/min is maintained.
3. Outputs are terminated through a 50- Ω resistor to -2 V.
4. Load circuit and switching waveforms are shown in Section 1.

SN10KHT5542, SN10KHT5543 OCTAL TTL-TO-ECL TRANSLATORS WITH OUTPUT ENABLE

SDZS001A – D3136, AUGUST 1988 – REVISED DECEMBER 1988

electrical characteristics over recommended operating ambient temperature range (unless otherwise noted) (see Note 2)

PARAMETER		TEST CONDITIONS		MIN	TYP†	MAX	UNIT
V_{IK}	A inputs and $\overline{OE}2$	$V_{CC} = 4.5\text{ V}, V_{EE} = -4.94\text{ V}, I_I = -18\text{ mA}$				-1.2	V
I_I	A inputs and $\overline{OE}2$	$V_{CC} = 5.5\text{ V}, V_{EE} = -5.46\text{ V}, V_I = 7\text{ V}$				0.1	mA
I_{IH}	A inputs and $\overline{OE}2$	$V_{CC} = 5.5\text{ V}, V_{EE} = -5.46\text{ V}, V_I = 2.7\text{ V}$				20	μA
	$\overline{OE}1$ only	$V_{CC} = 5.5\text{ V}, V_{EE} = -5.46\text{ V}, V_I = -840\text{ mV}$	0°C		350		
		$V_{CC} = 5.5\text{ V}, V_{EE} = -5.46\text{ V}, V_I = -810\text{ mV}$	25°C		350		
		$V_{CC} = 5.5\text{ V}, V_{EE} = -5.46\text{ V}, V_I = -735\text{ mV}$	75°C		350		
I_{IL}	A inputs and $\overline{OE}2$	$V_{CC} = 5.5\text{ V}, V_{EE} = -5.46\text{ V}, V_I = 0.5\text{ V}$				-500	μA
	$\overline{OE}1$ only	$V_{CC} = 5.5\text{ V}, V_{EE} = -5.46\text{ V}, V_I = -1950\text{ mV}$		0°C	0.5		
				25°C	0.5		
				75°C	0.5		
V_{OH}^\ddagger	$V_{CC} = 4.5\text{ V}, V_{EE} = -5.2\text{ V}, \pm 5\%, \text{ See Note 3}$		0°C	-1020	-840	mV	
			25°C	-980	-810		
			75°C	-920	-735		
V_{OL}^\ddagger	$V_{CC} = 4.5\text{ V}, V_{EE} = -5.2\text{ V}, \pm 5\%, \text{ See Note 3}$		0°C	-1950	-1630	mV	
			25°C	-1950	-1630		
			75°C	-1950	-1600		
I_{CCH}	$V_{CC} = 5.5\text{ V}, V_{EE} = -5.46\text{ V}$				17	25	mA
I_{CCL}	$V_{CC} = 5.5\text{ V}, V_{EE} = -5.46\text{ V}$				15	22	mA
I_{EE}	$V_{CC} = 5.5\text{ V}, V_{EE} = -5.46\text{ V}$				-77	-111	mA
C_i	$V_{CC} = 5\text{ V}, V_{EE} = -5.2\text{ V}, f = 10\text{ MHz}$				5		pF

switching characteristics over recommended ranges of operating ambient temperature and supply voltage (unless otherwise noted) (see Note 4)

PARAMETER	FROM (INPUT)	TO (OUTPUT)	MIN	TYP†	MAX	UNIT
t_{PLH}	Any A	Y	0.1	1.5	3	ns
t_{PHL}			0.1	1.5	3.3	
t_{PLH}	$\overline{OE}1$ (ECL)	Y	0.6	2.2	4.3	ns
t_{PHL}			0.5	2.4	4.3	
t_{PLH}	$\overline{OE}2$ (TTL)	Y	0.7	2.2	4.4	ns
t_{PHL}			0.5	2.6	4.7	
t_r		Y	1.5			ns
t_f			1.5			

† All typical values are at $V_{CC} = 5\text{ V}, V_{EE} = -5.2\text{ V}, T_A = 25^\circ\text{C}$.

‡ The algebraic convention, in which the least positive (most negative) value is designated minimum, is used in this data sheet for logic voltage levels and temperature only.

- NOTES: 2. Each 10KH series circuit has been designed to meet the dc specifications shown in the electrical characteristics table after thermal equilibrium has been established. The circuit is in a test socket or mounted on a printed circuit board and transverse air flow greater than 500 linear ft/min is maintained.
3. Outputs are terminated through a 50- Ω resistor to -2 V.
4. Load circuit and voltage waveforms are shown in Section 1.

PACKAGING INFORMATION

Orderable Device	Status ⁽¹⁾	Package Type	Package Drawing	Pins	Package Qty	Eco Plan ⁽²⁾	Lead/Ball Finish	MSL Peak Temp ⁽³⁾
SN10KHT5542DW	ACTIVE	SOIC	DW	24	25	TBD	Call TI	Call TI
SN10KHT5542DWE4	ACTIVE	SOIC	DW	24	25	TBD	Call TI	Call TI
SN10KHT5542DWG4	ACTIVE	SOIC	DW	24	25	TBD	Call TI	Call TI
SN10KHT5542DWR	OBSOLETE	SOIC	DW	24		TBD	Call TI	Call TI
SN10KHT5542NT	ACTIVE	PDIP	NT	24	15	Pb-Free (RoHS)	CU NIPDAU	N / A for Pkg Type
SN10KHT5542NTE4	ACTIVE	PDIP	NT	24	15	Pb-Free (RoHS)	CU NIPDAU	N / A for Pkg Type
SN10KHT5543DW	ACTIVE	SOIC	DW	24	25	Green (RoHS & no Sb/Br)	CU NIPDAU	Level-1-260C-UNLIM
SN10KHT5543DWR	ACTIVE	SOIC	DW	24	2000	Green (RoHS & no Sb/Br)	CU NIPDAU	Level-1-260C-UNLIM
SN10KHT5543DWRE4	ACTIVE	SOIC	DW	24	2000	Green (RoHS & no Sb/Br)	CU NIPDAU	Level-1-260C-UNLIM
SN10KHT5543DWRG4	ACTIVE	SOIC	DW	24	2000	Green (RoHS & no Sb/Br)	CU NIPDAU	Level-1-260C-UNLIM
SN10KHT5543NT	ACTIVE	PDIP	NT	24	15	Pb-Free (RoHS)	CU NIPDAU	N / A for Pkg Type
SN10KHT5543NTE4	ACTIVE	PDIP	NT	24	15	Pb-Free (RoHS)	CU NIPDAU	N / A for Pkg Type

⁽¹⁾ The marketing status values are defined as follows:

ACTIVE: Product device recommended for new designs.

LIFEBUY: TI has announced that the device will be discontinued, and a lifetime-buy period is in effect.

NRND: Not recommended for new designs. Device is in production to support existing customers, but TI does not recommend using this part in a new design.

PREVIEW: Device has been announced but is not in production. Samples may or may not be available.

OBSOLETE: TI has discontinued the production of the device.

⁽²⁾ Eco Plan - The planned eco-friendly classification: Pb-Free (RoHS), Pb-Free (RoHS Exempt), or Green (RoHS & no Sb/Br) - please check <http://www.ti.com/productcontent> for the latest availability information and additional product content details.

TBD: The Pb-Free/Green conversion plan has not been defined.

Pb-Free (RoHS): TI's terms "Lead-Free" or "Pb-Free" mean semiconductor products that are compatible with the current RoHS requirements for all 6 substances, including the requirement that lead not exceed 0.1% by weight in homogeneous materials. Where designed to be soldered at high temperatures, TI Pb-Free products are suitable for use in specified lead-free processes.

Pb-Free (RoHS Exempt): This component has a RoHS exemption for either 1) lead-based flip-chip solder bumps used between the die and package, or 2) lead-based die adhesive used between the die and leadframe. The component is otherwise considered Pb-Free (RoHS compatible) as defined above.

Green (RoHS & no Sb/Br): TI defines "Green" to mean Pb-Free (RoHS compatible), and free of Bromine (Br) and Antimony (Sb) based flame retardants (Br or Sb do not exceed 0.1% by weight in homogeneous material)

⁽³⁾ MSL, Peak Temp. -- The Moisture Sensitivity Level rating according to the JEDEC industry standard classifications, and peak solder temperature.

Important Information and Disclaimer:The information provided on this page represents TI's knowledge and belief as of the date that it is provided. TI bases its knowledge and belief on information provided by third parties, and makes no representation or warranty as to the accuracy of such information. Efforts are underway to better integrate information from third parties. TI has taken and continues to take reasonable steps to provide representative and accurate information but may not have conducted destructive testing or chemical analysis on incoming materials and chemicals. TI and TI suppliers consider certain information to be proprietary, and thus CAS numbers and other limited information may not be available for release.

In no event shall TI's liability arising out of such information exceed the total purchase price of the TI part(s) at issue in this document sold by TI to Customer on an annual basis.

TAPE AND REEL INFORMATION



QUADRANT ASSIGNMENTS FOR PIN 1 ORIENTATION IN TAPE

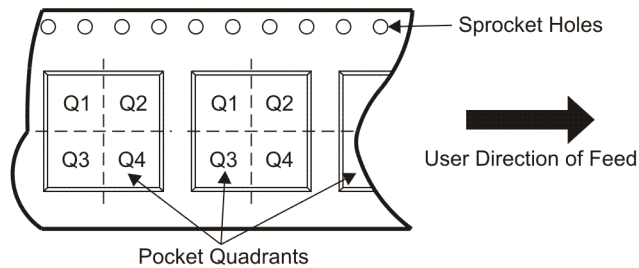

*All dimensions are nominal

Device	Package Type	Package Drawing	Pins	SPQ	Reel Diameter (mm)	Reel Width W1 (mm)	A0 (mm)	B0 (mm)	K0 (mm)	P1 (mm)	W (mm)	Pin1 Quadrant
SN10KHT5543DWR	SOIC	DW	24	2000	330.0	24.4	10.75	15.7	2.7	12.0	24.0	Q1

TAPE AND REEL BOX DIMENSIONS

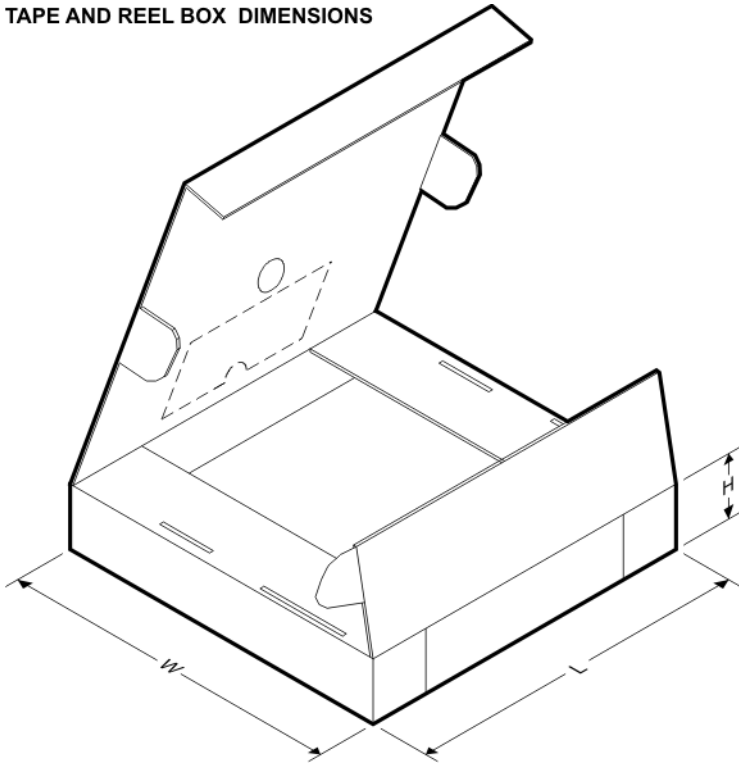

*All dimensions are nominal

Device	Package Type	Package Drawing	Pins	SPQ	Length (mm)	Width (mm)	Height (mm)
SN10KHT5543DWR	SOIC	DW	24	2000	346.0	346.0	41.0

NT (R-PDIP-T**)

PLASTIC DUAL-IN-LINE PACKAGE

24 PINS SHOWN

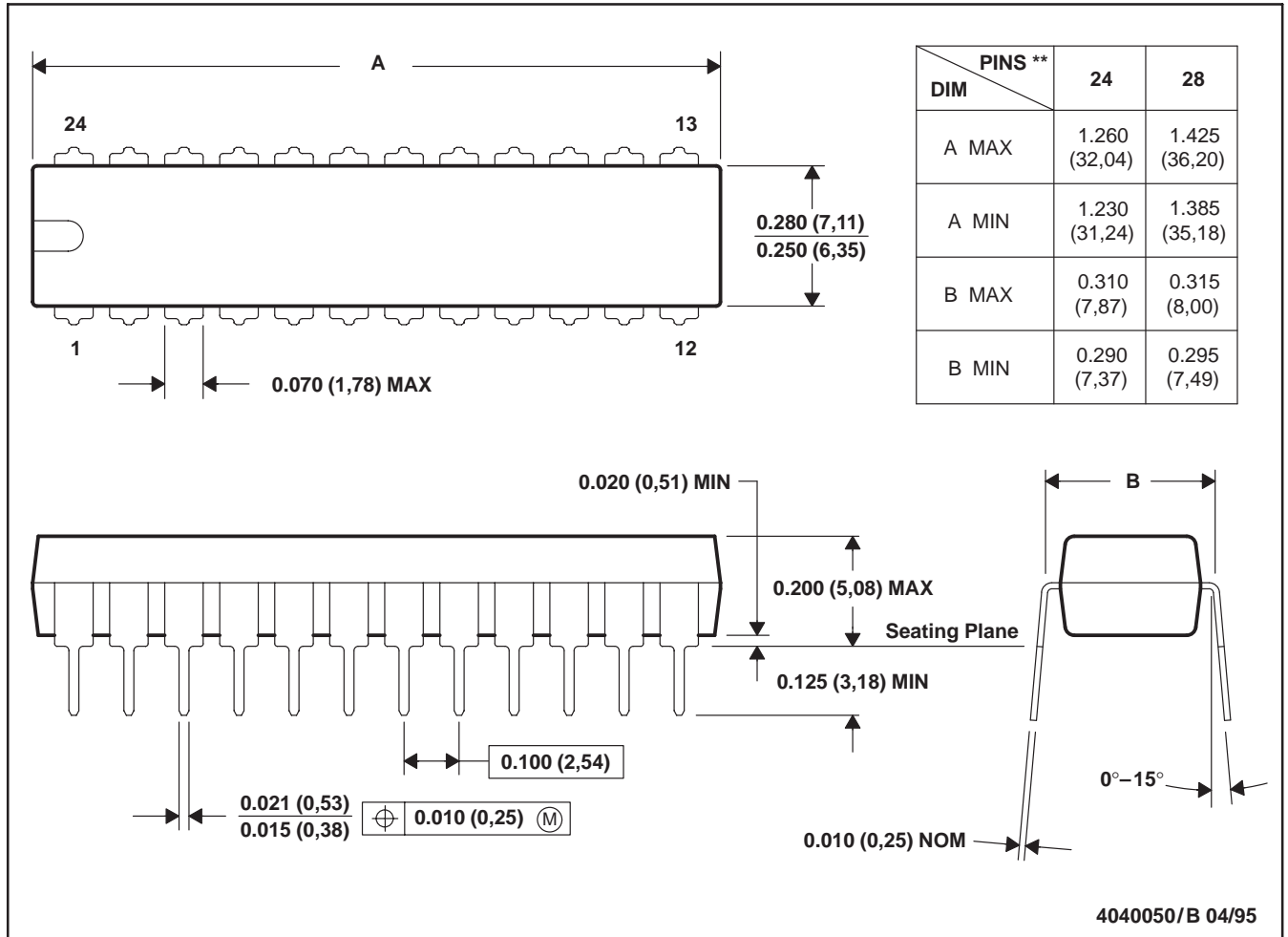

- NOTES: A. All linear dimensions are in inches (millimeters).
 B. This drawing is subject to change without notice.

IMPORTANT NOTICE

Texas Instruments Incorporated and its subsidiaries (TI) reserve the right to make corrections, modifications, enhancements, improvements, and other changes to its products and services at any time and to discontinue any product or service without notice. Customers should obtain the latest relevant information before placing orders and should verify that such information is current and complete. All products are sold subject to TI's terms and conditions of sale supplied at the time of order acknowledgment.

TI warrants performance of its hardware products to the specifications applicable at the time of sale in accordance with TI's standard warranty. Testing and other quality control techniques are used to the extent TI deems necessary to support this warranty. Except where mandated by government requirements, testing of all parameters of each product is not necessarily performed.

TI assumes no liability for applications assistance or customer product design. Customers are responsible for their products and applications using TI components. To minimize the risks associated with customer products and applications, customers should provide adequate design and operating safeguards.

TI does not warrant or represent that any license, either express or implied, is granted under any TI patent right, copyright, mask work right, or other TI intellectual property right relating to any combination, machine, or process in which TI products or services are used. Information published by TI regarding third-party products or services does not constitute a license from TI to use such products or services or a warranty or endorsement thereof. Use of such information may require a license from a third party under the patents or other intellectual property of the third party, or a license from TI under the patents or other intellectual property of TI.

Reproduction of TI information in TI data books or data sheets is permissible only if reproduction is without alteration and is accompanied by all associated warranties, conditions, limitations, and notices. Reproduction of this information with alteration is an unfair and deceptive business practice. TI is not responsible or liable for such altered documentation. Information of third parties may be subject to additional restrictions.

Resale of TI products or services with statements different from or beyond the parameters stated by TI for that product or service voids all express and any implied warranties for the associated TI product or service and is an unfair and deceptive business practice. TI is not responsible or liable for any such statements.

TI products are not authorized for use in safety-critical applications (such as life support) where a failure of the TI product would reasonably be expected to cause severe personal injury or death, unless officers of the parties have executed an agreement specifically governing such use. Buyers represent that they have all necessary expertise in the safety and regulatory ramifications of their applications, and acknowledge and agree that they are solely responsible for all legal, regulatory and safety-related requirements concerning their products and any use of TI products in such safety-critical applications, notwithstanding any applications-related information or support that may be provided by TI. Further, Buyers must fully indemnify TI and its representatives against any damages arising out of the use of TI products in such safety-critical applications.

TI products are neither designed nor intended for use in military/aerospace applications or environments unless the TI products are specifically designated by TI as military-grade or "enhanced plastic." Only products designated by TI as military-grade meet military specifications. Buyers acknowledge and agree that any such use of TI products which TI has not designated as military-grade is solely at the Buyer's risk, and that they are solely responsible for compliance with all legal and regulatory requirements in connection with such use.

TI products are neither designed nor intended for use in automotive applications or environments unless the specific TI products are designated by TI as compliant with ISO/TS 16949 requirements. Buyers acknowledge and agree that, if they use any non-designated products in automotive applications, TI will not be responsible for any failure to meet such requirements.

Following are URLs where you can obtain information on other Texas Instruments products and application solutions:

Products

Amplifiers	amplifier.ti.com
Data Converters	dataconverter.ti.com
DSP	dsp.ti.com
Clocks and Timers	www.ti.com/clocks
Interface	interface.ti.com
Logic	logic.ti.com
Power Mgmt	power.ti.com
Microcontrollers	microcontroller.ti.com
RFID	www.ti-rfid.com
RF/IF and ZigBee® Solutions	www.ti.com/lprf

Applications

Audio	www.ti.com/audio
Automotive	www.ti.com/automotive
Broadband	www.ti.com/broadband
Digital Control	www.ti.com/digitalcontrol
Medical	www.ti.com/medical
Military	www.ti.com/military
Optical Networking	www.ti.com/opticalnetwork
Security	www.ti.com/security
Telephony	www.ti.com/telephony
Video & Imaging	www.ti.com/video
Wireless	www.ti.com/wireless

Mailing Address: Texas Instruments, Post Office Box 655303, Dallas, Texas 75265
Copyright © 2008, Texas Instruments Incorporated