

SCANSTA476 Eight Input IEEE 1149.1 Analog Voltage Monitor

Check for Samples: [SCANSTA476](#)

FEATURES

- Eight Selectable Analog Input Channels
- Analog Full-Scale Input Range 0V to V_{DD}
- Typical Accuracy of 2 mV at Maximum V_{DD}
- Very Low Power Operation
- Small Package Footprint in 16-Lead, 5 x 5 x 0.8 mm WSON
- Single +2.7V to +5.5V Supply Operation
- IEEE 1149.1 (JTAG) Compliant Interface

APPLICATIONS

- Measurement of Point Voltages
- Real-time Signal Monitoring
- System Health Monitoring and Prognostics
- Debug, Environmental Test, Production Test, Field Service
- Supplement In-Circuit Tester (ICT) Access
- Vital in Servers, Computing, Telecommunication and Industrial Equipment
- Essential in Medical, Data Storage, and Networking Equipment

DESCRIPTION

The SCANSTA476 is a low power, Analog Voltage Monitor used for sampling or monitoring up to 8 analog/mixed-signal input channels. Analog Voltage Monitors are valuable during product development, environmental test, production, and field service for verifying and monitoring power supply and reference voltages. In a supervisory role, the 'STA476 is useful for card or system-level health monitoring and prognostics applications.

Instead of requiring an external microcontroller with a GPIO interface, the 'STA476 features a common IEEE 1149.1 (JTAG) interface to select the analog input, initiate a measurement, and access the results - further extending the capabilities of an existing JTAG infrastructure.

The SCANSTA476 uses the V_{REF} input as a reference. This enables the SCANSTA476 to operate with a full-scale input range of 0 to V_{DD} , which can range from +2.7V to +5.5V.

The SCANSTA476 is packaged in a 16-lead non-pullback WSON package that provides an extremely small footprint for applications where space is a critical consideration. This product operates over the industrial temperature range of -40°C to $+85^{\circ}\text{C}$.

Block Diagram

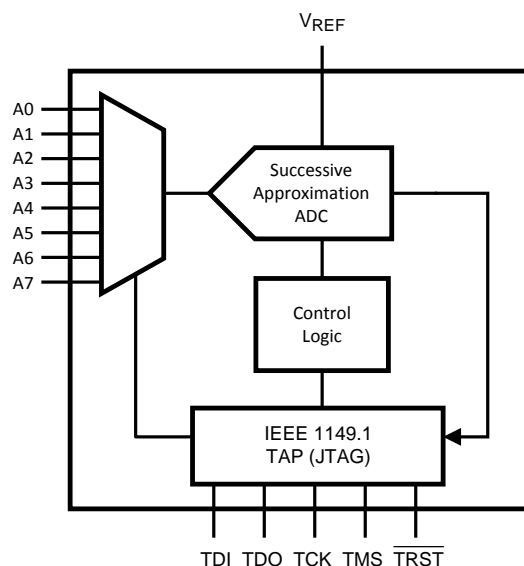

Please be aware that an important notice concerning availability, standard warranty, and use in critical applications of Texas Instruments semiconductor products and disclaimers thereto appears at the end of this data sheet.

All trademarks are the property of their respective owners.

Connection Diagram

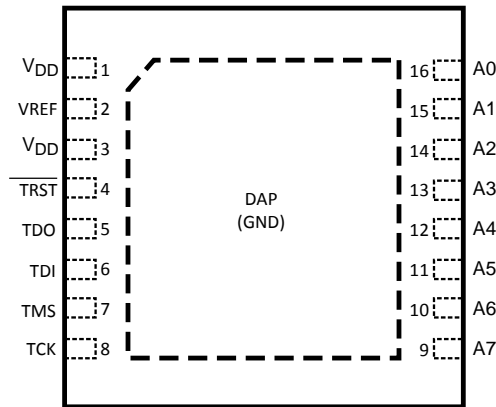

Figure 1. DAP = GND (Top View)

Pin Descriptions

Pin No.	Symbol	Description
ANALOG I/O		
16	A0	Analog input 0. This signal can range from 0V to V _{REF} .
15	A1	Analog input 1. This signal can range from 0V to V _{REF} .
14	A2	Analog input 2. This signal can range from 0V to V _{REF} .
13	A3	Analog input 3. This signal can range from 0V to V _{REF} .
12	A4	Analog input 4. This signal can range from 0V to V _{REF} .
11	A5	Analog input 5. This signal can range from 0V to V _{REF} .
10	A6	Analog input 6. This signal can range from 0V to V _{REF} .
9	A7	Analog input 7. This signal can range from 0V to V _{REF} .
2	V _{REF}	Analog reference voltage input. V _{REF} must be ≤ V _{DD} . This pin should be connected to a quiet source (not directly to V _{DD}) and bypassed to GND with 0.1 μF and 1 μF monolithic capacitors located within 1 cm of the V _{REF} pin.
DIGITAL I/O		
6	TDI	Test Data Input to support IEEE 1149.1 features
5	TDO	Test Data Output to support IEEE 1149.1 features
7	TMS	Test Mode Select to support IEEE 1149.1 features
8	TCK	Test Clock to support IEEE 1149.1 features
4	TRST	Test Reset to support IEEE 1149.1 features
POWER SUPPLY		
1,3	V _{DD}	Positive supply pin. These pins should be connected to a quiet +2.7V to +5.5V source and bypassed to GND with 0.1 μF and 1 μF monolithic capacitors located within 1 cm of the power pin.
See ⁽¹⁾	GND	Ground reference for CMOS circuitry. DAP is the exposed metal contact at the bottom of the WSON package. The DAP is used as the primary GND connection to the device. It should be connected to the ground plane with at least 4 vias for optimal low-noise and thermal performance.

(1) Note that GND is not an actual pin on the package, the GND is connected thru the DAP on the back side of the WSON package.



These devices have limited built-in ESD protection. The leads should be shorted together or the device placed in conductive foam during storage or handling to prevent electrostatic damage to the MOS gates.

Absolute Maximum Ratings ⁽¹⁾⁽²⁾

Supply Voltage V_{DD}		-0.3V to +6.5V
Voltage on Any Analog Pin to GND		-0.3V to $V_{DD}+0.3V$
Voltage on Any Digital Pin to GND		-0.3V to $V_{DD}+0.3V$
Input Current at Any Pin ⁽³⁾		±10 mA
ESD Susceptibility	Human Body Model	8000V
	Machine Model	>250V
Soldering Temperature		Refer to AN-1187 (SNOA401)
Junction Temperature		+150°C
Storage Temperature		-65°C to +150°C
Thermal Resistance, θ_{JA}		42°C/W
Thermal Resistance, θ_{JC}		14.3°C/W

- (1) Absolute maximum ratings are limiting values, to be applied individually, and beyond which the serviceability of the circuit may be impaired. Functional operability under any of these conditions is not implied. Exposure to maximum ratings for extended periods may affect device reliability.
- (2) If Military/Aerospace specified devices are required, please contact the TI Sales Office/ Distributors for availability and specifications.
- (3) Except power supply pins.

Recommended Operating Conditions

Operating Temperature Range	$-40^{\circ}\text{C} \leq T_A \leq +85^{\circ}\text{C}$
V_{DD} Supply Voltage	+2.7V to +5.5V
Digital Input Pins Voltage Range	+0V to V_{DD}
Analog Input Pins Voltage Range ⁽¹⁾	+0V to V_{REF}

- (1) For valid measurements, the analog $V_{IN} < V_{REF} \leq V_{DD}$.

SCANSTA476 Electrical Characteristics

The following specifications apply for $V_{DD} = +2.7V$ to 5.5V, $f_{TCK} = 20$ MHz, unless otherwise noted.

Symbol	Parameter	Conditions	Typical	Limits	Units
POWER SUPPLY CHARACTERISTICS					
V_{DD}	Supply Voltage	$-40^{\circ}\text{C} \leq T_A \leq 85^{\circ}\text{C}$		2.7	V (min)
				5.5	V (max)
I_{DD}	Normal Mode (Static)	$V_{DD} = +2.7V$ to +5.5V,	3.5	5.0	mA
	Normal Mode (Operational)	$V_{DD} = +2.7V$ to +5.5V, $f_{TCK} = 1$ MSPS			
P_D	Power Consumption, Normal Mode (Operational)	$V_{DD} = +5.5V$, $f_{TCK} = 1$ MSPS		27.5	mW (max)
ANALOG INPUT CHARACTERISTICS (A0-A7)					
V_{IN}	Analog Input Range	$V_{REF} \leq V_{DD}$		0 to V_{REF}	V
V_{REF}	Reference Voltage Range			V_{DD}	V
I_{DCL}	DC Leakage Current		0.1	±10	µA (max)
V_{MEAS}	Analog Input Measurement Accuracy	$V_{DD} = +2.7V$	1	7.5	mV
		$V_{DD} = +5.5V$	2	15	
DIGITAL INPUT CHARACTERISTICS (TDI, TMS, TCK, TRST)					
V_{IH}	Input High Voltage	$V_{DD} = +2.7V$ to +3.6V		2.0	V (min)
		$V_{DD} = +5.5V$		2.1	
V_{IL}	Input Low Voltage	$V_{DD} = +5V$		0.8	V (max)
V_{CL}	Input Clamp Voltage	$I_{CL} = -18\text{mA}$	-0.8	-1.5	V (max)
I_{IN}	Input Current	$V_{IN} = 0V$ or V_{DD}	0.2	±10	µA (max)

SCANSTA476 Electrical Characteristics (continued)

The following specifications apply for $V_{DD} = +2.7V$ to $5.5V$, $f_{TCK} = 20$ MHz, unless otherwise noted.

Symbol	Parameter	Conditions	Typical	Limits	Units
I_{ILR}	Input Current	\overline{TRST} , TDI, TMS only		-300	μA (max)
DIGITAL OUTPUT CHARACTERISTICS (TDO)					
V_{OH}	Output High Voltage	$I_{OH} = -100 \mu A, 2.7V \leq V_{DD} \leq 5.5V$		$V_{DD} - 0.2$	V (min)
		$I_{OH} = -4 mA, 3.0V \leq V_{DD} \leq 5.5V$		2.4	V (min)
		$I_{OH} = -4 mA, V_{DD} = 2.7V$		2.2	V (min)
V_{OL}	Output Low Voltage	$I_{OL} = 100 \mu A, 2.7V \leq V_{DD} \leq 5.5V$		0.2	V (max)
		$I_{OL} = 4 mA, 2.7V \leq V_{DD} \leq 5.5V$		0.4	V (max)
I_{OS}	Output Short Circuit Current	$V_{OUT} = 0V, V_{DD} = 5.5V$		-85	mA (max)
I_{OZ}	TRI-STATE Leakage Current			± 10	μA (max)
	Output Coding		Straight (Natural) Binary		
AC ELECTRICAL CHARACTERISTICS					
F_{MAX}	Throughput Rate	TCK = 20MHz		1	MSPS (max)
INPUT TIMING CHARACTERISTICS					
t_{SET}	TDI to TCK (H/L)	See ⁽¹⁾		2.0	ns (min)
t_{HOLD}	TDI to TCK (H/L)	See ⁽¹⁾		1.5	ns (min)
t_{SET}	TMS to TCK (H/L)	See ⁽¹⁾		2.0	ns (min)
t_{HOLD}	TMS to TCK (H/L)	See ⁽¹⁾		2.0	ns (min)
t_W	TCK Pulse Width (H/L)	See ⁽¹⁾		10.0	ns (min)
t_{REC}	Recovery Time \overline{TRST} to TCK	See ⁽¹⁾		2.0	ns (min)
t_W	TRST Pulse Width (L)	See ⁽¹⁾		2.5	ns (min)
F_{MAX}	TCK			20	MHz (min)

(1) Data sheet min/max specification limits are specified by design or statistical analysis.

APPLICATIONS INFORMATION

POWER-UP TIMING

The SCANSTA476 typically requires 1 μs to power up, either after first applying V_{DD} , or after an incomplete conversion shift. To return to normal, one "dummy" conversion must be fully completed. After this first dummy conversion, the SCANSTA476 will perform conversions properly.

STARTUP MODE

When the V_{DD} supply is first applied, the SCANSTA476 requires one dummy conversion after start-up.

Timing Diagrams

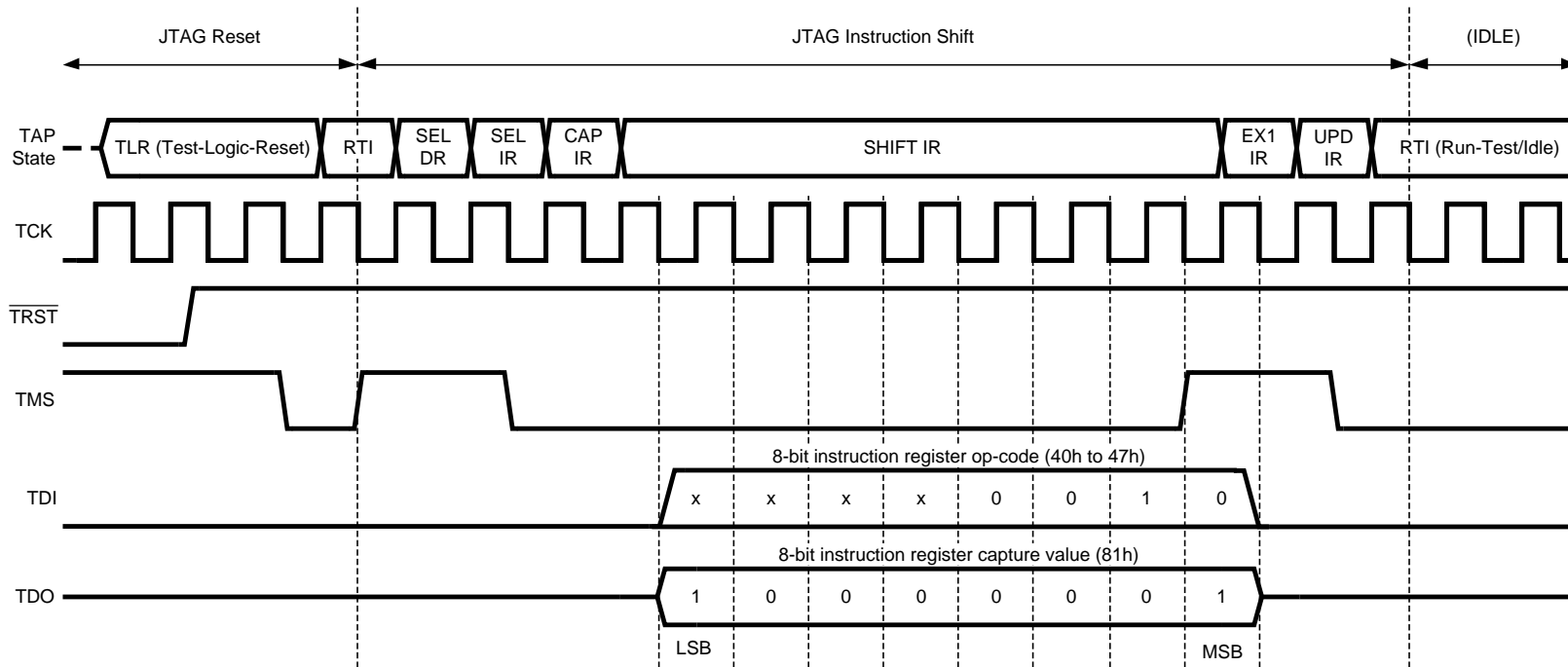

Op-codes 40h to 47h select pins A0 to A7 respectively.

Note the JTAG reset preamble places the JTAG TAP controller in a stable state (RTI). Both the instruction and data shifts start in - and return to - the RTI state

Figure 2. Instruction Shift (Channel Select)

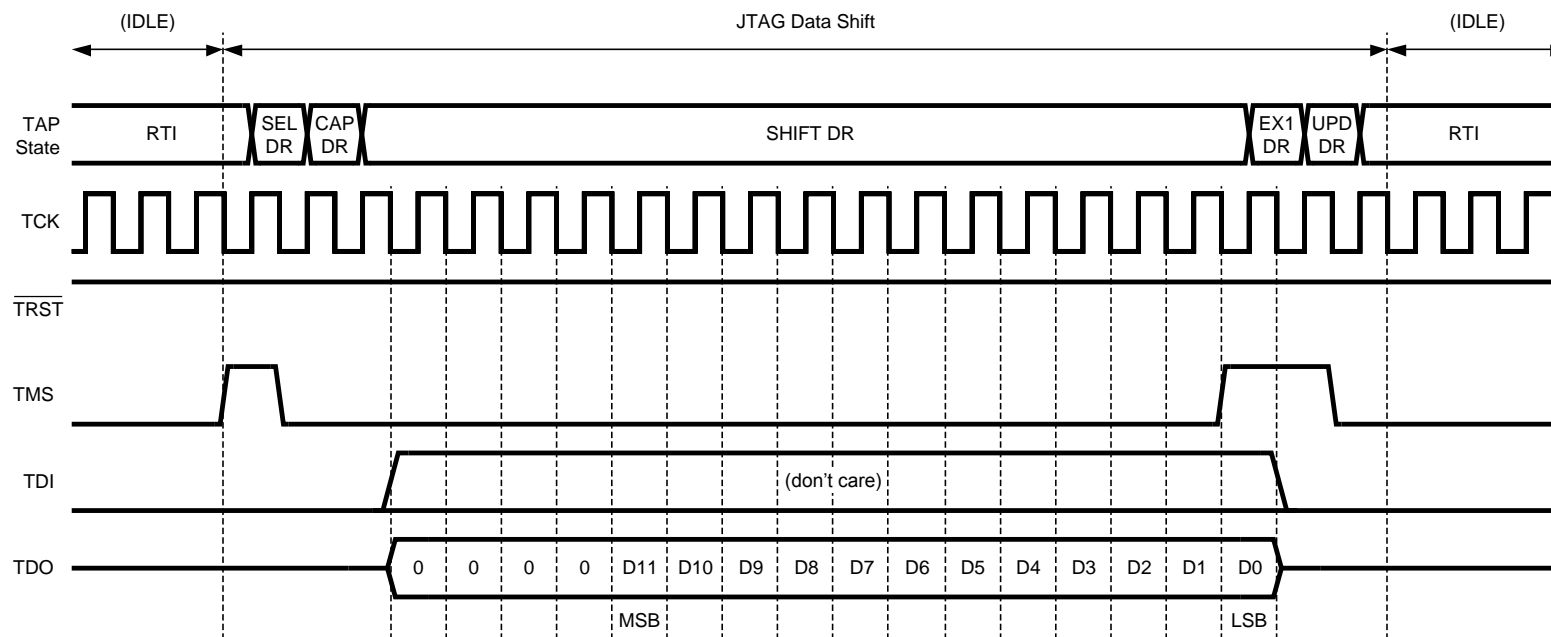

D11 through D0 correspond to the 12-bit sample from the ADC Core.

Note that Data shifts can be run back-to-back for continuous sampling of a single channel, or can be interleaved with instruction shifts for rippling through all 8 channels.

Figure 3. Data Shift (A/D Sample)

REVISION HISTORY

Changes from Revision F (April 2013) to Revision G	Page
• Changed layout of National Data Sheet to TI format	6

PACKAGING INFORMATION

Orderable Device	Status (1)	Package Type	Package Drawing	Pins	Package Qty	Eco Plan (2)	Lead/Ball Finish	MSL Peak Temp (3)	Op Temp (°C)	Top-Side Markings (4)	Samples
SCANSTA476TSD	ACTIVE	WSON	NHQ	16	1000	TBD	Call TI	Call TI	-40 to 85	STA476T	Samples
SCANSTA476TSD/NOPB	ACTIVE	WSON	NHQ	16	1000	Green (RoHS & no Sb/Br)	CU SN	Level-3-260C-168 HR	-40 to 85	STA476T	Samples

(1) The marketing status values are defined as follows:

ACTIVE: Product device recommended for new designs.

LIFEBUY: TI has announced that the device will be discontinued, and a lifetime-buy period is in effect.

NRND: Not recommended for new designs. Device is in production to support existing customers, but TI does not recommend using this part in a new design.

PREVIEW: Device has been announced but is not in production. Samples may or may not be available.

OBSOLETE: TI has discontinued the production of the device.

(2) Eco Plan - The planned eco-friendly classification: Pb-Free (RoHS), Pb-Free (RoHS Exempt), or Green (RoHS & no Sb/Br) - please check <http://www.ti.com/productcontent> for the latest availability information and additional product content details.

TBD: The Pb-Free/Green conversion plan has not been defined.

Pb-Free (RoHS): TI's terms "Lead-Free" or "Pb-Free" mean semiconductor products that are compatible with the current RoHS requirements for all 6 substances, including the requirement that lead not exceed 0.1% by weight in homogeneous materials. Where designed to be soldered at high temperatures, TI Pb-Free products are suitable for use in specified lead-free processes.

Pb-Free (RoHS Exempt): This component has a RoHS exemption for either 1) lead-based flip-chip solder bumps used between the die and package, or 2) lead-based die adhesive used between the die and leadframe. The component is otherwise considered Pb-Free (RoHS compatible) as defined above.

Green (RoHS & no Sb/Br): TI defines "Green" to mean Pb-Free (RoHS compatible), and free of Bromine (Br) and Antimony (Sb) based flame retardants (Br or Sb do not exceed 0.1% by weight in homogeneous material)

(3) MSL, Peak Temp. -- The Moisture Sensitivity Level rating according to the JEDEC industry standard classifications, and peak solder temperature.

(4) Multiple Top-Side Markings will be inside parentheses. Only one Top-Side Marking contained in parentheses and separated by a "~" will appear on a device. If a line is indented then it is a continuation of the previous line and the two combined represent the entire Top-Side Marking for that device.

Important Information and Disclaimer: The information provided on this page represents TI's knowledge and belief as of the date that it is provided. TI bases its knowledge and belief on information provided by third parties, and makes no representation or warranty as to the accuracy of such information. Efforts are underway to better integrate information from third parties. TI has taken and continues to take reasonable steps to provide representative and accurate information but may not have conducted destructive testing or chemical analysis on incoming materials and chemicals. TI and TI suppliers consider certain information to be proprietary, and thus CAS numbers and other limited information may not be available for release.

In no event shall TI's liability arising out of such information exceed the total purchase price of the TI part(s) at issue in this document sold by TI to Customer on an annual basis.

NHQ0016A

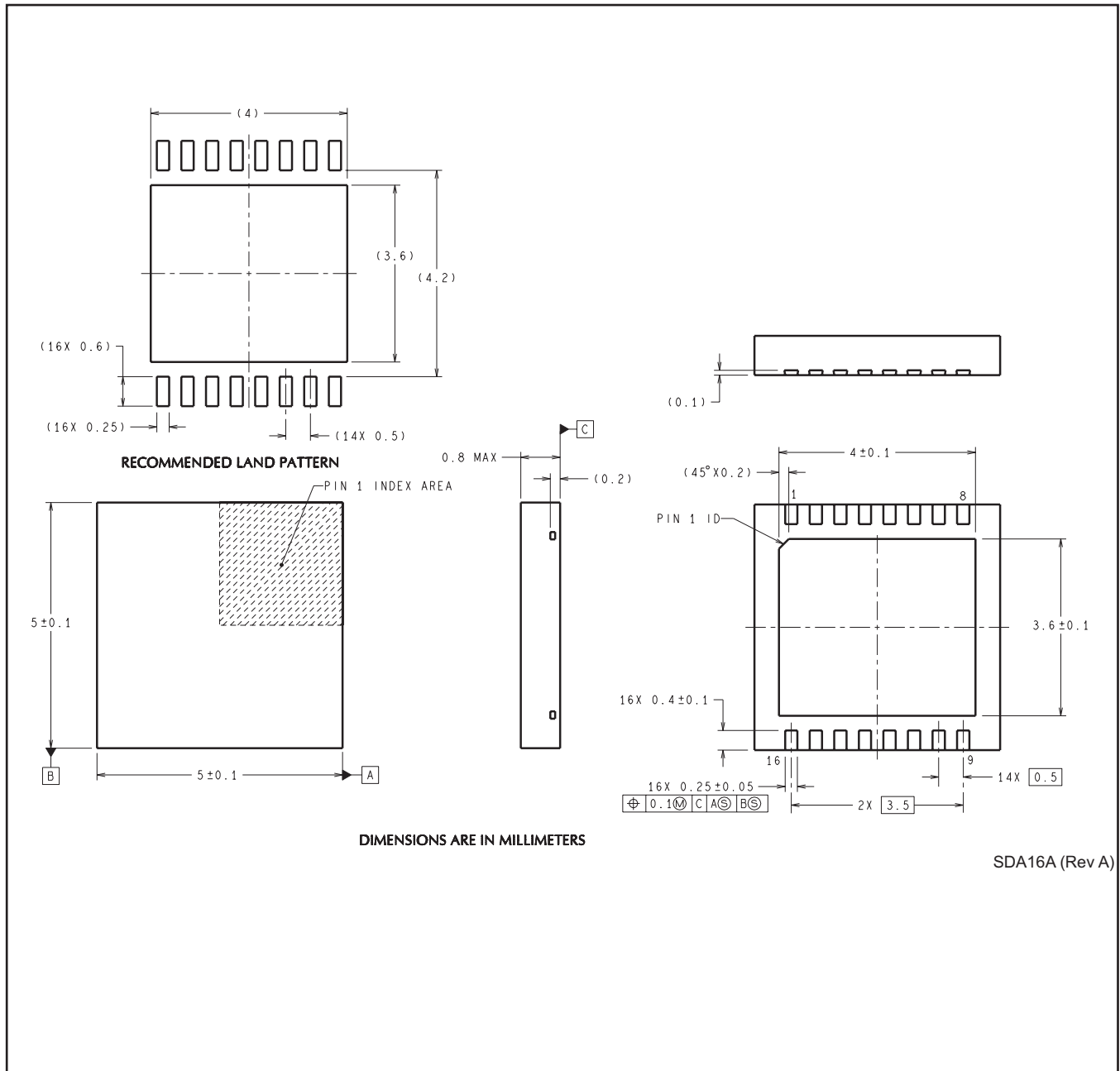

IMPORTANT NOTICE

Texas Instruments Incorporated and its subsidiaries (TI) reserve the right to make corrections, enhancements, improvements and other changes to its semiconductor products and services per JESD46, latest issue, and to discontinue any product or service per JESD48, latest issue. Buyers should obtain the latest relevant information before placing orders and should verify that such information is current and complete. All semiconductor products (also referred to herein as "components") are sold subject to TI's terms and conditions of sale supplied at the time of order acknowledgment.

TI warrants performance of its components to the specifications applicable at the time of sale, in accordance with the warranty in TI's terms and conditions of sale of semiconductor products. Testing and other quality control techniques are used to the extent TI deems necessary to support this warranty. Except where mandated by applicable law, testing of all parameters of each component is not necessarily performed.

TI assumes no liability for applications assistance or the design of Buyers' products. Buyers are responsible for their products and applications using TI components. To minimize the risks associated with Buyers' products and applications, Buyers should provide adequate design and operating safeguards.

TI does not warrant or represent that any license, either express or implied, is granted under any patent right, copyright, mask work right, or other intellectual property right relating to any combination, machine, or process in which TI components or services are used. Information published by TI regarding third-party products or services does not constitute a license to use such products or services or a warranty or endorsement thereof. Use of such information may require a license from a third party under the patents or other intellectual property of the third party, or a license from TI under the patents or other intellectual property of TI.

Reproduction of significant portions of TI information in TI data books or data sheets is permissible only if reproduction is without alteration and is accompanied by all associated warranties, conditions, limitations, and notices. TI is not responsible or liable for such altered documentation. Information of third parties may be subject to additional restrictions.

Resale of TI components or services with statements different from or beyond the parameters stated by TI for that component or service voids all express and any implied warranties for the associated TI component or service and is an unfair and deceptive business practice. TI is not responsible or liable for any such statements.

Buyer acknowledges and agrees that it is solely responsible for compliance with all legal, regulatory and safety-related requirements concerning its products, and any use of TI components in its applications, notwithstanding any applications-related information or support that may be provided by TI. Buyer represents and agrees that it has all the necessary expertise to create and implement safeguards which anticipate dangerous consequences of failures, monitor failures and their consequences, lessen the likelihood of failures that might cause harm and take appropriate remedial actions. Buyer will fully indemnify TI and its representatives against any damages arising out of the use of any TI components in safety-critical applications.

In some cases, TI components may be promoted specifically to facilitate safety-related applications. With such components, TI's goal is to help enable customers to design and create their own end-product solutions that meet applicable functional safety standards and requirements. Nonetheless, such components are subject to these terms.

No TI components are authorized for use in FDA Class III (or similar life-critical medical equipment) unless authorized officers of the parties have executed a special agreement specifically governing such use.

Only those TI components which TI has specifically designated as military grade or "enhanced plastic" are designed and intended for use in military/aerospace applications or environments. Buyer acknowledges and agrees that any military or aerospace use of TI components which have **not** been so designated is solely at the Buyer's risk, and that Buyer is solely responsible for compliance with all legal and regulatory requirements in connection with such use.

TI has specifically designated certain components as meeting ISO/TS16949 requirements, mainly for automotive use. In any case of use of non-designated products, TI will not be responsible for any failure to meet ISO/TS16949.

Products

Audio	www.ti.com/audio
Amplifiers	amplifier.ti.com
Data Converters	dataconverter.ti.com
DLP® Products	www.dlp.com
DSP	dsp.ti.com
Clocks and Timers	www.ti.com/clocks
Interface	interface.ti.com
Logic	logic.ti.com
Power Mgmt	power.ti.com
Microcontrollers	microcontroller.ti.com
RFID	www.ti-rfid.com
OMAP Applications Processors	www.ti.com/omap
Wireless Connectivity	www.ti.com/wirelessconnectivity

Applications

Automotive and Transportation	www.ti.com/automotive
Communications and Telecom	www.ti.com/communications
Computers and Peripherals	www.ti.com/computers
Consumer Electronics	www.ti.com/consumer-apps
Energy and Lighting	www.ti.com/energy
Industrial	www.ti.com/industrial
Medical	www.ti.com/medical
Security	www.ti.com/security
Space, Avionics and Defense	www.ti.com/space-avionics-defense
Video and Imaging	www.ti.com/video

TI E2E Community

e2e.ti.com