



3.9µA, SC70-3, 30ppm/°C Drift VOLTAGE REFERENCE

FEATURES

- **MICROSIZE PACKAGES:** SC70-3, SOT23-3
- **LOW SUPPLY CURRENT:** 3.9µA (typ)
- **HIGH OUTPUT CURRENT:** ±5mA
- **LOW TEMPERATURE DRIFT:** 30ppm/°C (max)
- **HIGH INITIAL ACCURACY:** ±0.15% (max)

APPLICATIONS

- **PORTABLE EQUIPMENT**
- **DATA ACQUISITION SYSTEMS**
- **MEDICAL EQUIPMENT**
- **TEST EQUIPMENT**

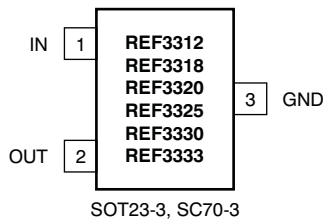

DESCRIPTION

The REF33xx is a low-power, precision, low-dropout voltage reference family available in the tiny SC70-3 and SOT23-3 packages. Small size and low power consumption (5µA max) make the REF33xx ideal for a wide variety of portable and battery-powered applications.

The REF33xx can be operated at a supply voltage 180mV above the specified output voltage under normal load conditions, with the exception of the REF3312, which has a minimum supply voltage of 1.8V. All models are specified for the wide temperature range, –40°C to +125°C.

REF33xx PRODUCT FAMILY

PRODUCT	DESCRIPTION
REF3312	1.25V
REF3318	1.8V
REF3320	2.048V
REF3325	2.5V
REF3330	3.0V
REF3333	3.3V



Please be aware that an important notice concerning availability, standard warranty, and use in critical applications of Texas Instruments semiconductor products and disclaimers thereto appears at the end of this data sheet.

All trademarks are the property of their respective owners.



This integrated circuit can be damaged by ESD. Texas Instruments recommends that all integrated circuits be handled with appropriate precautions. Failure to observe proper handling and installation procedures can cause damage.

ESD damage can range from subtle performance degradation to complete device failure. Precision integrated circuits may be more susceptible to damage because very small parametric changes could cause the device not to meet its published specifications.

ORDERING INFORMATION⁽¹⁾

PRODUCT	DESCRIPTION	PACKAGE	PACKAGE DESIGNATOR	PACKAGE MARKING
REF3312	1.25V	SOT23-3	DBZ	R33A
		SC70-3	DCK	R12
REF3318	1.8V	SOT23-3	DBZ	R33B
		SC70-3	DCK	R18
REF3320	2.048V	SOT23-3	DBZ	R33C
		SC70-3	DCK	R20
REF3325	2.5V	SOT23-3	DBZ	R33D
		SC70-3	DCK	R25
REF3330	3.0V	SOT23-3	DBZ	R33E
		SC70-3	DCK	R30
REF3333	3.3V	SOT23-3	DBZ	R33F
		SC70-3	DCK	R33

(1) For the most current package and ordering information see the Package Option Addendum at the end of this document, or see the TI web site at www.ti.com.

ABSOLUTE MAXIMUM RATINGS⁽¹⁾

	VALUE	UNIT
Input Voltage (V_{IN})	+7.5	V
Output Short-Circuit (I_{SC})	180	mA
Output Voltage (OUT pin) ⁽²⁾	5	V
Operating Temperature	–50 to +150	°C
Storage Temperature	–65 to +150	°C
Junction Temperature (T_J)	+150	°C
ESD Ratings	Human Body Model (HBM)	4000
	Charged Device Model (CDM)	1000
	Machine Model (MM)	200

(1) Stresses above these ratings may cause permanent damage. Exposure to absolute maximum conditions for extended periods may degrade device reliability. These are stress ratings only, and functional operation of the device at these or any other conditions beyond those specified is not implied.

(2) See the [Applications Information](#) section, [Supply Voltage](#).

PIN CONFIGURATION

REF3312, REF3318, REF3320, REF3325, REF3330, REF3333
 SOT23-3, SC70-3
 TOP VIEW

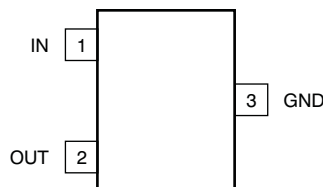

ELECTRICAL CHARACTERISTICS: $V_{IN} = +5V$
Boldface limits apply over the specified temperature range, -40°C to $+125^{\circ}\text{C}$.

 At $T_A = +25^{\circ}\text{C}$ and $I_{LOAD} = 0\text{mA}$, unless otherwise noted.

PARAMETER	CONDITIONS	REF33xx			UNITS
		MIN	TYP	MAX	
REF3312 (1.25V)					
OUTPUT VOLTAGE					
Initial Accuracy	V_{OUT} $V_{IN} = 5V$	-0.15	1.25	+0.15	V %
NOISE					
Output Voltage Noise	$f = 0.1\text{Hz to }10\text{Hz}$		35		μV_{PP}
REF3318 (1.8V)					
OUTPUT VOLTAGE					
Initial Accuracy	V_{OUT} $V_{IN} = 5V$	-0.15	1.8	+0.15	V %
NOISE					
Output Voltage Noise	$f = 0.1\text{Hz to }10\text{Hz}$		50		μV_{PP}
REF3320 (2.048V)					
OUTPUT VOLTAGE					
Initial Accuracy	V_{OUT} $V_{IN} = 5V$	-0.15	2.048	+0.15	V %
NOISE					
Output Voltage Noise	$f = 0.1\text{Hz to }10\text{Hz}$		55		μV_{PP}
REF3325 (2.5V)					
OUTPUT VOLTAGE					
Initial Accuracy	V_{OUT} $V_{IN} = 5V$	-0.15	2.5	+0.15	V %
NOISE					
Output Voltage Noise	$f = 0.1\text{Hz to }10\text{Hz}$		70		μV_{PP}
REF3330 (3.0V)					
OUTPUT VOLTAGE					
Initial Accuracy	V_{OUT} $V_{IN} = 5V$	-0.15	3.0	+0.15	V %
NOISE					
Output Voltage Noise	$f = 0.1\text{Hz to }10\text{Hz}$		84		μV_{PP}
REF3333 (3.3V)					
OUTPUT VOLTAGE					
Initial Accuracy	V_{OUT} $V_{IN} = 5V$	-0.15	3.3	+0.15	V %
NOISE					
Output Voltage Noise	$f = 0.1\text{Hz to }10\text{Hz}$		92		μV_{PP}

ELECTRICAL CHARACTERISTICS: $V_{IN} = +5V$ (continued)

Boldface limits apply over the specified temperature range, $-40^{\circ}C$ to $+125^{\circ}C$.
At $T_A = +25^{\circ}C$ and $I_{LOAD} = 0mA$, unless otherwise noted.

PARAMETER	CONDITIONS	REF33xx			UNITS
		MIN	TYP	MAX	
REF33xx (REF3312, REF3318, REF3320, REF3325, REF3330, REF3333)					
OUTPUT VOLTAGE TEMPERATURE DRIFT					
	dV_{OUT}/dT	$-40^{\circ}C$ to $+85^{\circ}C$	9	30	ppm/ $^{\circ}C$
		$-40^{\circ}C$ to $+125^{\circ}C$	8	30	ppm/$^{\circ}C$
LINE REGULATION					
	dV_{OUT}/dV_{IN}	$V_{IN} = V_{OUT} + 200mV$ to $5.5V^{(1)}$	–50	6	ppm/V
		$0^{\circ}C$ to $+70^{\circ}C$		6	ppm/V
Over Temperature		$-40^{\circ}C$ to $+85^{\circ}C$		8	ppm/V
		$-40^{\circ}C$ to $+125^{\circ}C$		30	ppm/V
LOAD REGULATION					
	dV_{OUT}/dI_{LOAD}	$V_{IN} = V_{OUT} + 200mV^{(1)}$	–50	6	ppm/mA
		$I_{LOAD} = \pm 5mA$, $0^{\circ}C$ to $+70^{\circ}C$		10	ppm/mA
Over Temperature		$-40^{\circ}C$ to $+85^{\circ}C$		20	ppm/mA
		$-40^{\circ}C$ to $+125^{\circ}C$		20	ppm/mA
THERMAL HYSTERESIS	$dT^{(2)}$			90	ppm
MINIMUM DROPOUT VOLTAGE	$V_{IN} - V_{OUT}^{(1)}$				
		$I_{LOAD} = \pm 5mA$		110	mV
Over Temperature		$0^{\circ}C$ to $+70^{\circ}C$		120	mV
		$-40^{\circ}C$ to $+85^{\circ}C$		135	mV
		$-40^{\circ}C$ to $+125^{\circ}C$		180	mV
		$I_{LOAD} = \pm 2mA$, $-40^{\circ}C$ to $+85^{\circ}C$		70	mV
SHORT-CIRCUIT CURRENT					
Sourcing/Sinking	I_{SC}			35	mA
CAPACITIVE LOAD			0.1	10	μF
TURN-ON SETTLING TIME		To 0.1% with $C_L = 1\mu F$		2	ms
POWER SUPPLY					
Specified Voltage Range	V_S		$V_{OUT} + 0.2^{(1)}$	5.5	V
Operating Voltage Range		$I_{LOAD} = 0mA$	$V_{OUT} + 0.005$	5.5	V
Current	I_Q	$V_{IN} = 5V$		3.9	μA
Over Temperature		$-40^{\circ}C$ to $+85^{\circ}C$		4.4	μA
		$-40^{\circ}C$ to $+125^{\circ}C$		4.8	μA
TEMPERATURE RANGE					
Specified Range	T_A		–40	+125	$^{\circ}C$
Operating Range	T_A		–50	+150	$^{\circ}C$
Thermal Resistance	θ_{JA}				
SC70-3				300	$^{\circ}C/W$
SOT23-3				300	$^{\circ}C/W$

(1) The minimum supply voltage for the REF3312 is 1.8V.

(2) The thermal hysteresis procedure is explained in more detail in the [Applications Information](#) section.

TYPICAL CHARACTERISTICS

At $T_A = +25^\circ\text{C}$ and $V_{IN} = +5\text{V}$. REF3325 is used for typical characteristic measurements, unless otherwise noted.

**TEMPERATURE DRIFT
(0°C to $+70^\circ\text{C}$)**

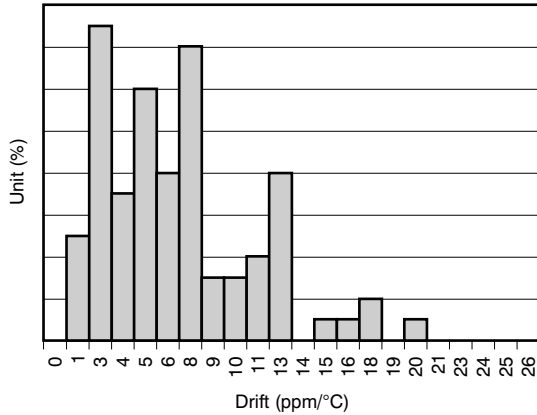

Figure 1.

**TEMPERATURE DRIFT
(-40°C to $+125^\circ\text{C}$)**

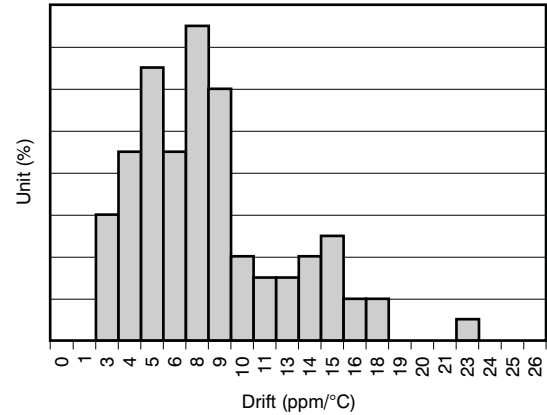

Figure 2.

**OUTPUT VOLTAGE ACCURACY
vs TEMPERATURE**

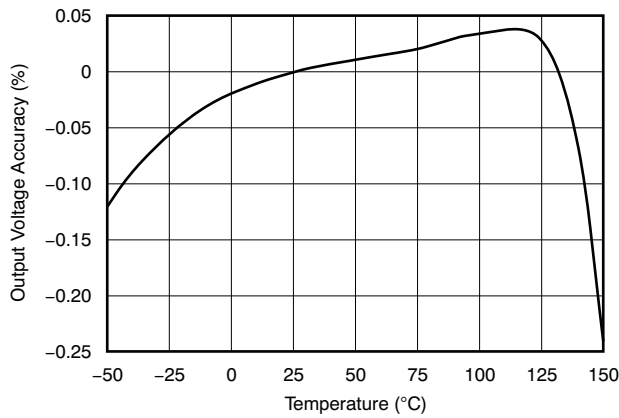

Figure 3.

**DROPOUT VOLTAGE
vs LOAD CURRENT**

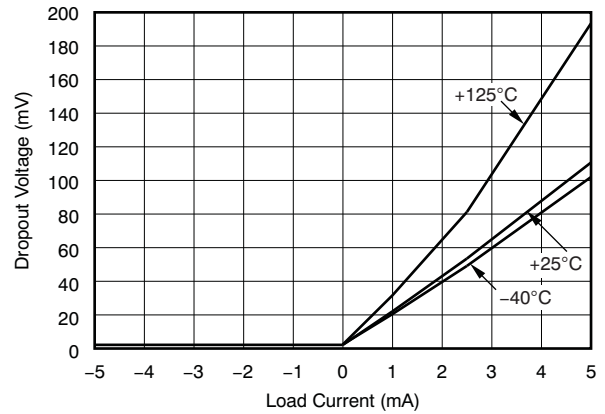

Figure 4.

QUIESCENT CURRENT vs TEMPERATURE

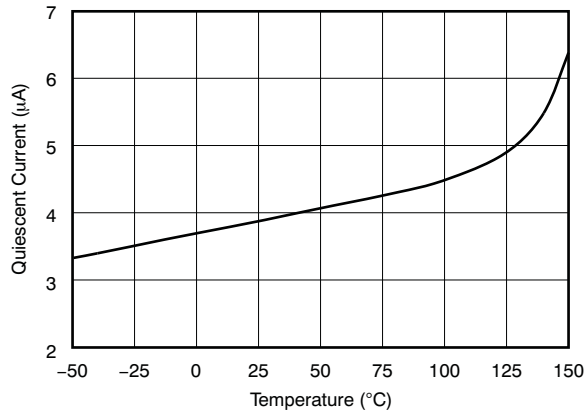

Figure 5.

OUTPUT IMPEDANCE vs FREQUENCY

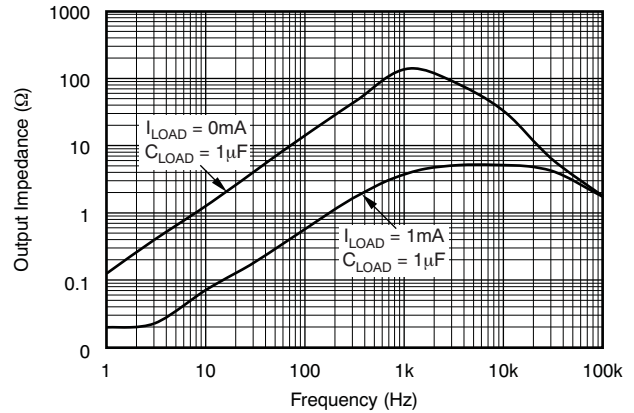

Figure 6.

TYPICAL CHARACTERISTICS (continued)

At $T_A = +25^\circ\text{C}$ and $V_{IN} = +5\text{V}$. REF3325 is used for typical characteristic measurements, unless otherwise noted.

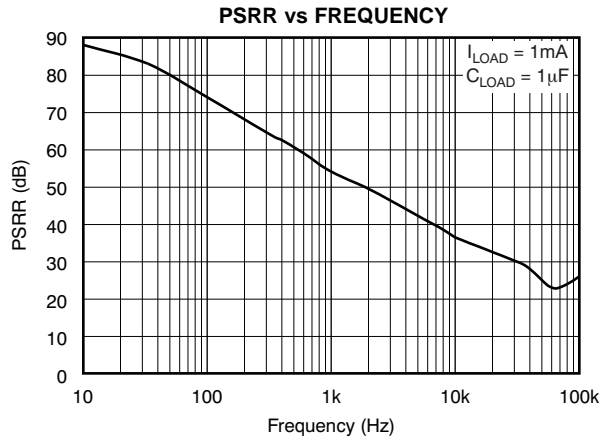

Figure 7.

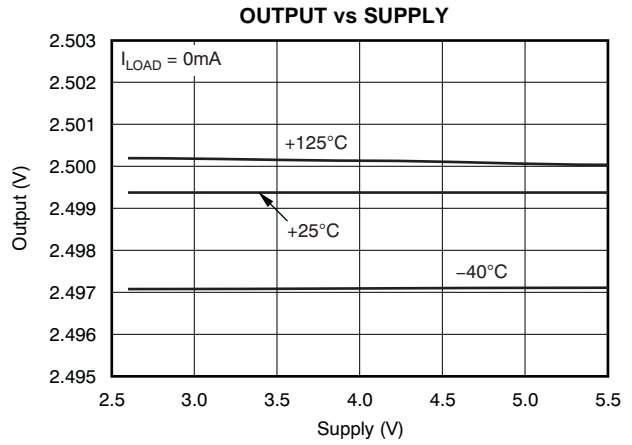

Figure 8.

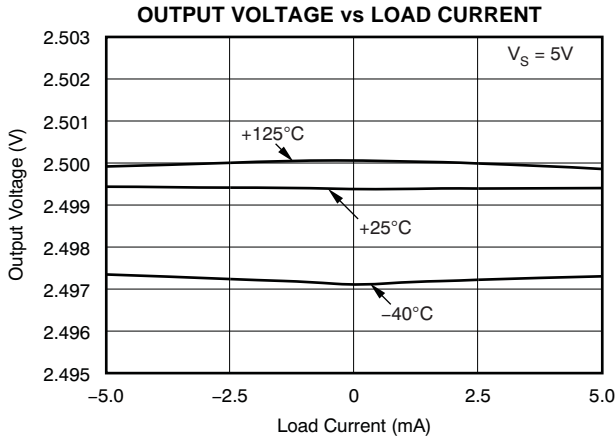

Figure 9.

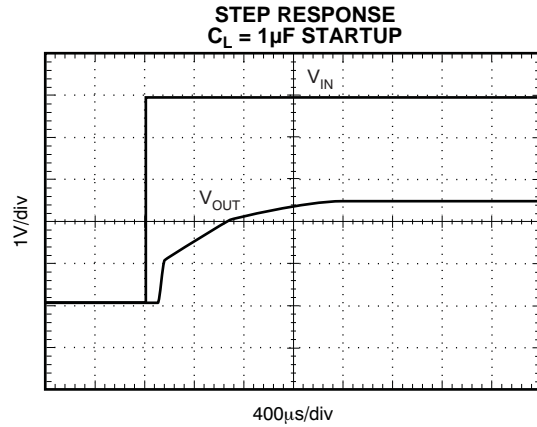

Figure 10.

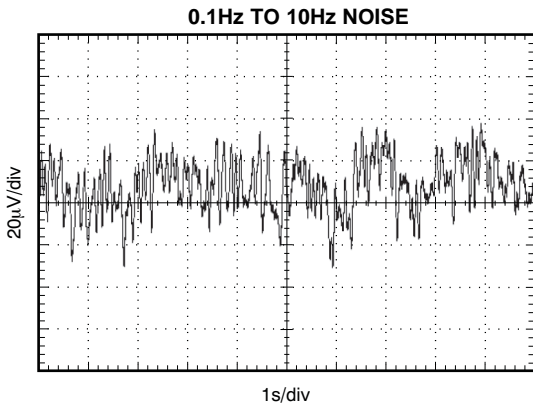

Figure 11.

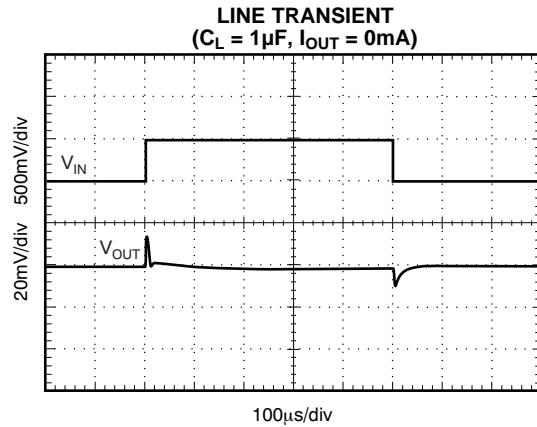
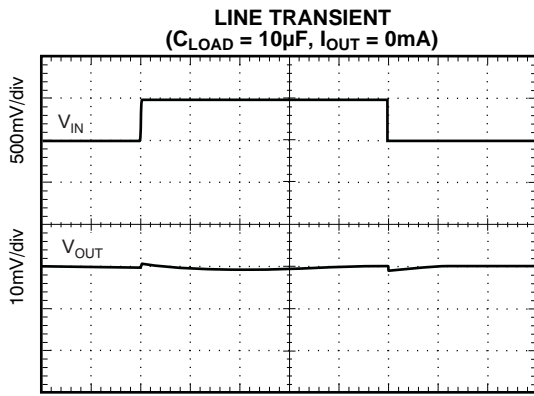

Figure 12.

TYPICAL CHARACTERISTICS (continued)

At $T_A = +25^\circ\text{C}$ and $V_{IN} = +5\text{V}$. REF3325 is used for typical characteristic measurements, unless otherwise noted.



Time (400 μs /div)

Figure 13.

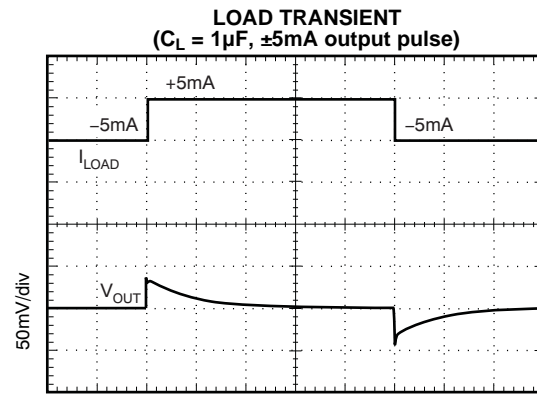

200 μs /div

Figure 14.

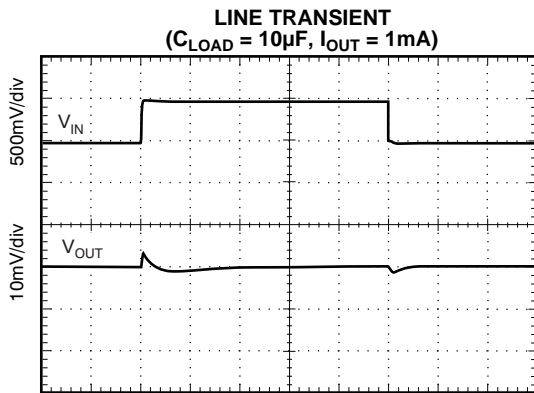

Time (200 μs /div)

Figure 15.

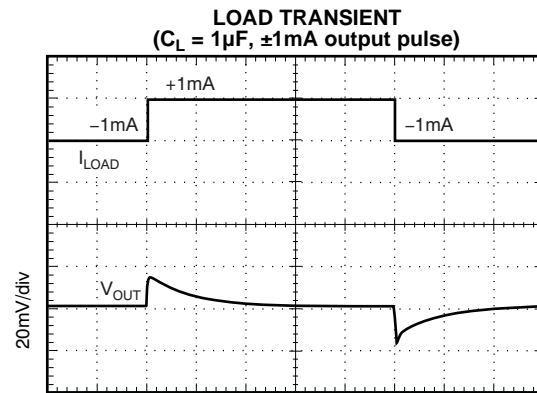

200 μs /div

Figure 16.

APPLICATIONS INFORMATION

The REF33xx is a family of low-power, precision bandgap voltage references that are specifically designed for excellent initial voltage accuracy with a high output current. Figure 17 shows a simplified block diagram of the REF33xx.

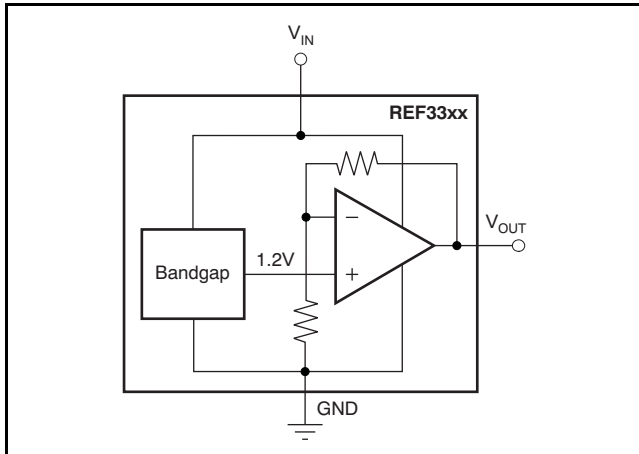

Figure 17. REF33xx Simplified Block Diagram

BASIC CONNECTIONS

Figure 18 shows the typical connections for the REF33xx. A recommended supply bypass capacitor ranging between 1µF to 10µF is recommended. The total capacitive load at the output must be between 0.1µF to 10µF to ensure output stability.

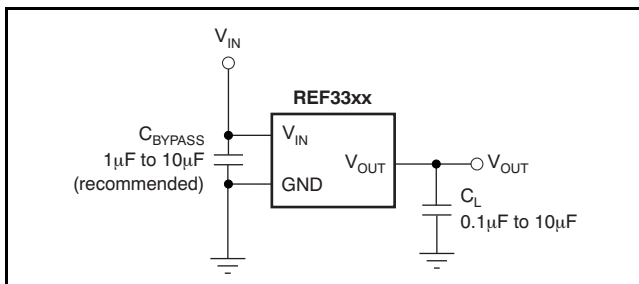

Figure 18. Basic Connections

SUPPLY VOLTAGE

The REF33xx family of voltage references features extremely low dropout voltage, except for the REF3312. The REF3312 has a minimum supply requirement of 1.8V. These references can be operated with a supply 110mV above the output voltage with a 5mA load (typical). For loaded conditions, a typical dropout voltage versus load graph is illustrated in Figure 4 of the *Typical Characteristics*.

If the supply voltage connected to the IN pin is rapidly moved while the REF33xx is connected to a capacitive load, a reverse voltage may discharge through the OUT pin and into the REF33xx device. This voltage will not damage the REF33xx, provided that it is less than or equal to 5V.

START-UP TIME

The REF33xx features an advanced start-up circuit. Start-up time is almost independent of load (with a 0.1µF to 10µF load). Upon start-up, the current boost circuit forces the output voltage. When the preset voltage is reached, the REF33xx switches to the second stage of output circuitry to precisely set the output voltage. Figure 19 shows the start-up time of the REF3325 for three different capacitive loads. In all three cases, the output voltage settles within 2ms.

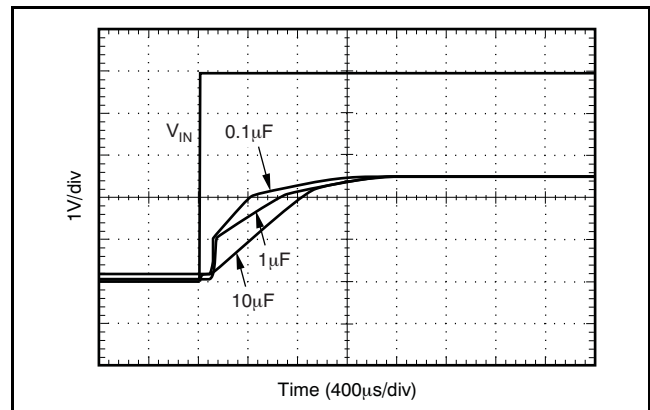

Figure 19. Start-Up Time

TEMPERATURE DRIFT

The REF33xx is designed for minimal drift error, defined as the change in output voltage over temperature. The drift is calculated using the box method, as described in Equation 1:

$$\text{Drift} = \left[\frac{V_{\text{OUTMAX}} - V_{\text{OUTMIN}}}{V_{\text{OUT}} \times \text{Temp Range}} \right] \times 10^6 (\text{ppm}) \quad (1)$$

POWER DISSIPATION

The REF33xx family is specified to deliver current loads of $\pm 5\text{mA}$ over the specified input voltage range. The temperature of the device increases according to Equation 2:

$$T_J = T_A + P_D \times \theta_{JA} \quad (2)$$

Where:

T_J = Junction temperature ($^{\circ}\text{C}$)

T_A = Ambient temperature ($^{\circ}\text{C}$)

P_D = Power dissipation (W)

Where $P_D = V_{IN} \times I_Q + (V_{IN} - V_{OUT}) I_{OUT}$

θ_{JA} = Junction-to-ambient thermal resistance ($^{\circ}\text{C}/\text{W}$)

The REF33xx junction temperature must not exceed the absolute maximum rating of $+150^{\circ}\text{C}$.

NOISE PERFORMANCE

Typical 0.1Hz to 10Hz voltage noise for each member of the REF33xx family is specified in the [Electrical Characteristics](#) table. The noise voltage increases with output voltage and operating temperature. Additional filtering can be used to improve output noise levels. Special attention should be taken to ensure that the output impedance does not degrade output voltage accuracy.

APPLICATION CIRCUITS

Figure 20 shows a simple application circuit where low-power components are used to create a signal chain. The analog input signal is buffered with either a zero-drift [OPA333](#) or zero-crossover [OPA363](#). The reference voltage created from REF3312 provides a stable, high-accuracy, low-drift reference voltage to the [MSP430](#) using much less power than the MSP430 internal reference. The reference voltage is used by the internal, 16-bit analog-to-digital converter (ADC) to accurately convert the analog input signal. The configuration in Figure 20 presents an example of a unipolar signal chain.

An example of a bipolar configuration is illustrated in Figure 21. The analog input signal ($\pm 2.5\text{V}$) is offset and attenuated so that it matches the analog input of the 16-bit ADC on the MSP430. The negative input of the ADC is offset by 0.62V, creating a digital code that corresponds to the analog input voltage. In this configuration, two reference voltages are used. The REF3312 creates a 1.25V reference input to the ADC and is an offset point for the [INA159](#). The same voltage is used to create the offset voltage to the negative input to the ADC. The REF3330 creates a precise analog supply voltage of 3V. In this way, the high PSRR of the REF3330 helps to filter unwanted noise from the 3.3V digital supply.

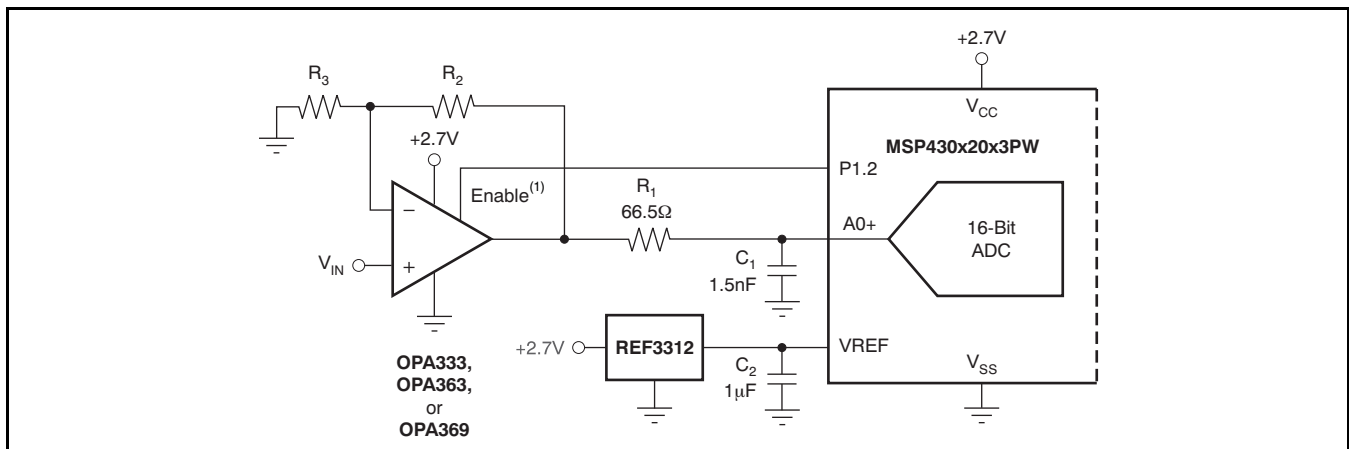

(1) Enable is a function of the OPA363 not available on the OPA333.

Figure 20. Unipolar Signal Chain Configuration

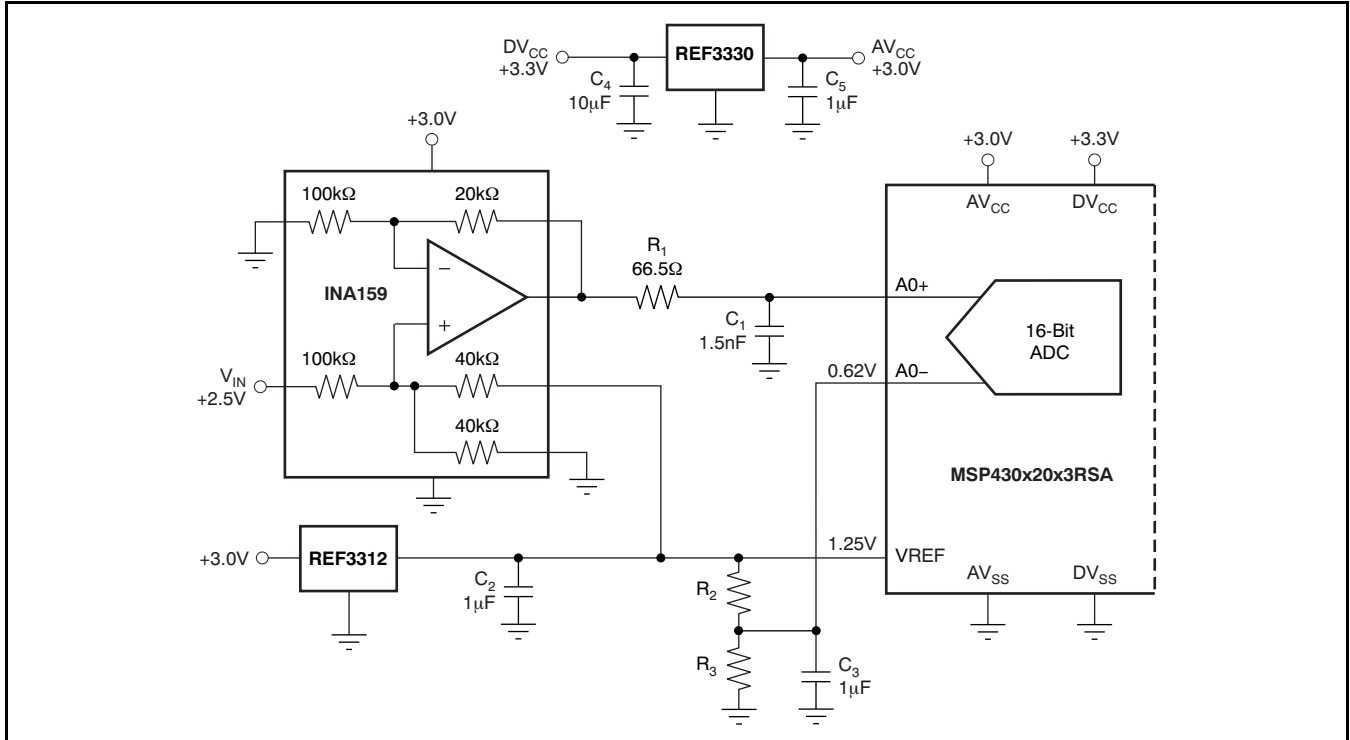

Figure 21. Bipolar Signal Chain Configuration

PACKAGING INFORMATION

Orderable Device	Status ⁽¹⁾	Package Type	Package Drawing	Pins	Package Qty	Eco Plan ⁽²⁾	Lead/ Ball Finish	MSL Peak Temp ⁽³⁾	Samples (Requires Login)
REF3312AIDBZR	ACTIVE	SOT-23	DBZ	3	3000	Green (RoHS & no Sb/Br)	CU NIPDAU	Level-2-260C-1 YEAR	
REF3312AIDBZRG4	ACTIVE	SOT-23	DBZ	3	3000	Green (RoHS & no Sb/Br)	CU NIPDAU	Level-2-260C-1 YEAR	
REF3312AIDBZT	ACTIVE	SOT-23	DBZ	3	250	Green (RoHS & no Sb/Br)	CU NIPDAU	Level-2-260C-1 YEAR	
REF3312AIDBZTG4	ACTIVE	SOT-23	DBZ	3	250	Green (RoHS & no Sb/Br)	CU NIPDAU	Level-2-260C-1 YEAR	
REF3312AIDCKR	ACTIVE	SC70	DCK	3	3000	Green (RoHS & no Sb/Br)	CU NIPDAU	Level-2-260C-1 YEAR	
REF3312AIDCKRG4	ACTIVE	SC70	DCK	3	3000	Green (RoHS & no Sb/Br)	CU NIPDAU	Level-2-260C-1 YEAR	
REF3312AIDCKT	ACTIVE	SC70	DCK	3	250	Green (RoHS & no Sb/Br)	CU NIPDAU	Level-2-260C-1 YEAR	
REF3312AIDCKTG4	ACTIVE	SC70	DCK	3	250	Green (RoHS & no Sb/Br)	CU NIPDAU	Level-2-260C-1 YEAR	
REF3318AIDBZR	ACTIVE	SOT-23	DBZ	3	3000	Green (RoHS & no Sb/Br)	CU NIPDAU	Level-2-260C-1 YEAR	
REF3318AIDBZRG4	ACTIVE	SOT-23	DBZ	3	3000	Green (RoHS & no Sb/Br)	CU NIPDAU	Level-2-260C-1 YEAR	
REF3318AIDBZT	ACTIVE	SOT-23	DBZ	3	250	Green (RoHS & no Sb/Br)	CU NIPDAU	Level-2-260C-1 YEAR	
REF3318AIDBZTG4	ACTIVE	SOT-23	DBZ	3	250	Green (RoHS & no Sb/Br)	CU NIPDAU	Level-2-260C-1 YEAR	
REF3318AIDCKR	ACTIVE	SC70	DCK	3	3000	Green (RoHS & no Sb/Br)	CU NIPDAU	Level-2-260C-1 YEAR	
REF3318AIDCKRG4	ACTIVE	SC70	DCK	3	3000	Green (RoHS & no Sb/Br)	CU NIPDAU	Level-2-260C-1 YEAR	
REF3318AIDCKT	ACTIVE	SC70	DCK	3	250	Green (RoHS & no Sb/Br)	CU NIPDAU	Level-2-260C-1 YEAR	
REF3318AIDCKTG4	ACTIVE	SC70	DCK	3	250	Green (RoHS & no Sb/Br)	CU NIPDAU	Level-2-260C-1 YEAR	
REF3320AIDBZR	ACTIVE	SOT-23	DBZ	3	3000	Green (RoHS & no Sb/Br)	CU NIPDAU	Level-2-260C-1 YEAR	

Orderable Device	Status ⁽¹⁾	Package Type	Package Drawing	Pins	Package Qty	Eco Plan ⁽²⁾	Lead/ Ball Finish	MSL Peak Temp ⁽³⁾	Samples (Requires Login)
REF3320AIDBZRG4	ACTIVE	SOT-23	DBZ	3	3000	Green (RoHS & no Sb/Br)	CU NIPDAU	Level-2-260C-1 YEAR	
REF3320AIDBZT	ACTIVE	SOT-23	DBZ	3	250	Green (RoHS & no Sb/Br)	CU NIPDAU	Level-2-260C-1 YEAR	
REF3320AIDBZTG4	ACTIVE	SOT-23	DBZ	3	250	Green (RoHS & no Sb/Br)	CU NIPDAU	Level-2-260C-1 YEAR	
REF3320AIDCKR	ACTIVE	SC70	DCK	3	3000	Green (RoHS & no Sb/Br)	CU NIPDAU	Level-2-260C-1 YEAR	
REF3320AIDCKRG4	ACTIVE	SC70	DCK	3	3000	Green (RoHS & no Sb/Br)	CU NIPDAU	Level-2-260C-1 YEAR	
REF3320AIDCKT	ACTIVE	SC70	DCK	3	250	Green (RoHS & no Sb/Br)	CU NIPDAU	Level-2-260C-1 YEAR	
REF3320AIDCKTG4	ACTIVE	SC70	DCK	3	250	Green (RoHS & no Sb/Br)	CU NIPDAU	Level-2-260C-1 YEAR	
REF3325AIDBZR	ACTIVE	SOT-23	DBZ	3	3000	Green (RoHS & no Sb/Br)	CU NIPDAU	Level-2-260C-1 YEAR	
REF3325AIDBZRG4	ACTIVE	SOT-23	DBZ	3	3000	Green (RoHS & no Sb/Br)	CU NIPDAU	Level-2-260C-1 YEAR	
REF3325AIDBZT	ACTIVE	SOT-23	DBZ	3	250	Green (RoHS & no Sb/Br)	CU NIPDAU	Level-2-260C-1 YEAR	
REF3325AIDBZTG4	ACTIVE	SOT-23	DBZ	3	250	Green (RoHS & no Sb/Br)	CU NIPDAU	Level-2-260C-1 YEAR	
REF3325AIDCKR	ACTIVE	SC70	DCK	3	3000	Green (RoHS & no Sb/Br)	CU NIPDAU	Level-2-260C-1 YEAR	
REF3325AIDCKRG4	ACTIVE	SC70	DCK	3	3000	Green (RoHS & no Sb/Br)	CU NIPDAU	Level-2-260C-1 YEAR	
REF3325AIDCKT	ACTIVE	SC70	DCK	3	250	Green (RoHS & no Sb/Br)	CU NIPDAU	Level-2-260C-1 YEAR	
REF3325AIDCKTG4	ACTIVE	SC70	DCK	3	250	Green (RoHS & no Sb/Br)	CU NIPDAU	Level-2-260C-1 YEAR	
REF3330AIDBZR	ACTIVE	SOT-23	DBZ	3	3000	Green (RoHS & no Sb/Br)	CU NIPDAU	Level-2-260C-1 YEAR	
REF3330AIDBZRG4	ACTIVE	SOT-23	DBZ	3	3000	Green (RoHS & no Sb/Br)	CU NIPDAU	Level-2-260C-1 YEAR	
REF3330AIDBZT	ACTIVE	SOT-23	DBZ	3	250	Green (RoHS & no Sb/Br)	CU NIPDAU	Level-2-260C-1 YEAR	

Orderable Device	Status ⁽¹⁾	Package Type	Package Drawing	Pins	Package Qty	Eco Plan ⁽²⁾	Lead/ Ball Finish	MSL Peak Temp ⁽³⁾	Samples (Requires Login)
REF3330AIDBZTG4	ACTIVE	SOT-23	DBZ	3	250	Green (RoHS & no Sb/Br)	CU NIPDAU	Level-2-260C-1 YEAR	
REF3330AIDCKR	ACTIVE	SC70	DCK	3	3000	Green (RoHS & no Sb/Br)	CU NIPDAU	Level-2-260C-1 YEAR	
REF3330AIDCKRG4	ACTIVE	SC70	DCK	3	3000	Green (RoHS & no Sb/Br)	CU NIPDAU	Level-2-260C-1 YEAR	
REF3330AIDCKT	ACTIVE	SC70	DCK	3	250	Green (RoHS & no Sb/Br)	CU NIPDAU	Level-2-260C-1 YEAR	
REF3330AIDCKTG4	ACTIVE	SC70	DCK	3	250	Green (RoHS & no Sb/Br)	CU NIPDAU	Level-2-260C-1 YEAR	
REF3333AIDBZR	ACTIVE	SOT-23	DBZ	3	3000	Green (RoHS & no Sb/Br)	CU NIPDAU	Level-2-260C-1 YEAR	
REF3333AIDBZRG4	ACTIVE	SOT-23	DBZ	3	3000	Green (RoHS & no Sb/Br)	CU NIPDAU	Level-2-260C-1 YEAR	
REF3333AIDBZT	ACTIVE	SOT-23	DBZ	3	250	Green (RoHS & no Sb/Br)	CU NIPDAU	Level-2-260C-1 YEAR	
REF3333AIDBZTG4	ACTIVE	SOT-23	DBZ	3	250	Green (RoHS & no Sb/Br)	CU NIPDAU	Level-2-260C-1 YEAR	
REF3333AIDCKR	ACTIVE	SC70	DCK	3	3000	Green (RoHS & no Sb/Br)	CU NIPDAU	Level-2-260C-1 YEAR	
REF3333AIDCKRG4	ACTIVE	SC70	DCK	3	3000	Green (RoHS & no Sb/Br)	CU NIPDAU	Level-2-260C-1 YEAR	
REF3333AIDCKT	ACTIVE	SC70	DCK	3	250	Green (RoHS & no Sb/Br)	CU NIPDAU	Level-2-260C-1 YEAR	
REF3333AIDCKTG4	ACTIVE	SC70	DCK	3	250	Green (RoHS & no Sb/Br)	CU NIPDAU	Level-2-260C-1 YEAR	

⁽¹⁾ The marketing status values are defined as follows:

ACTIVE: Product device recommended for new designs.

LIFEBUY: TI has announced that the device will be discontinued, and a lifetime-buy period is in effect.

NRND: Not recommended for new designs. Device is in production to support existing customers, but TI does not recommend using this part in a new design.

PREVIEW: Device has been announced but is not in production. Samples may or may not be available.

OBSOLETE: TI has discontinued the production of the device.

⁽²⁾ Eco Plan - The planned eco-friendly classification: Pb-Free (RoHS), Pb-Free (RoHS Exempt), or Green (RoHS & no Sb/Br) - please check <http://www.ti.com/productcontent> for the latest availability information and additional product content details.

TBD: The Pb-Free/Green conversion plan has not been defined.

Pb-Free (RoHS): TI's terms "Lead-Free" or "Pb-Free" mean semiconductor products that are compatible with the current RoHS requirements for all 6 substances, including the requirement that lead not exceed 0.1% by weight in homogeneous materials. Where designed to be soldered at high temperatures, TI Pb-Free products are suitable for use in specified lead-free processes.

Pb-Free (RoHS Exempt): This component has a RoHS exemption for either 1) lead-based flip-chip solder bumps used between the die and package, or 2) lead-based die adhesive used between the die and leadframe. The component is otherwise considered Pb-Free (RoHS compatible) as defined above.

Green (RoHS & no Sb/Br): TI defines "Green" to mean Pb-Free (RoHS compatible), and free of Bromine (Br) and Antimony (Sb) based flame retardants (Br or Sb do not exceed 0.1% by weight in homogeneous material)

⁽³⁾ MSL, Peak Temp. -- The Moisture Sensitivity Level rating according to the JEDEC industry standard classifications, and peak solder temperature.

Important Information and Disclaimer: The information provided on this page represents TI's knowledge and belief as of the date that it is provided. TI bases its knowledge and belief on information provided by third parties, and makes no representation or warranty as to the accuracy of such information. Efforts are underway to better integrate information from third parties. TI has taken and continues to take reasonable steps to provide representative and accurate information but may not have conducted destructive testing or chemical analysis on incoming materials and chemicals. TI and TI suppliers consider certain information to be proprietary, and thus CAS numbers and other limited information may not be available for release.

In no event shall TI's liability arising out of such information exceed the total purchase price of the TI part(s) at issue in this document sold by TI to Customer on an annual basis.

TAPE AND REEL INFORMATION

QUADRANT ASSIGNMENTS FOR PIN 1 ORIENTATION IN TAPE

*All dimensions are nominal

Device	Package Type	Package Drawing	Pins	SPQ	Reel Diameter (mm)	Reel Width W1 (mm)	A0 (mm)	B0 (mm)	K0 (mm)	P1 (mm)	W (mm)	Pin1 Quadrant
REF3312AIDBZR	SOT-23	DBZ	3	3000	179.0	8.4	3.15	2.95	1.22	4.0	8.0	Q3
REF3312AIDBZT	SOT-23	DBZ	3	250	179.0	8.4	3.15	2.95	1.22	4.0	8.0	Q3
REF3312AIDCKR	SC70	DCK	3	3000	179.0	8.4	2.4	2.4	1.19	4.0	8.0	Q3
REF3312AIDCKT	SC70	DCK	3	250	179.0	8.4	2.4	2.4	1.19	4.0	8.0	Q3
REF3318AIDBZR	SOT-23	DBZ	3	3000	179.0	8.4	3.15	2.95	1.22	4.0	8.0	Q3
REF3318AIDBZT	SOT-23	DBZ	3	250	179.0	8.4	3.15	2.95	1.22	4.0	8.0	Q3
REF3318AIDCKR	SC70	DCK	3	3000	179.0	8.4	2.4	2.4	1.19	4.0	8.0	Q3
REF3318AIDCKT	SC70	DCK	3	250	179.0	8.4	2.4	2.4	1.19	4.0	8.0	Q3
REF3320AIDBZR	SOT-23	DBZ	3	3000	179.0	8.4	3.15	2.95	1.22	4.0	8.0	Q3
REF3320AIDBZT	SOT-23	DBZ	3	250	179.0	8.4	3.15	2.95	1.22	4.0	8.0	Q3
REF3320AIDCKR	SC70	DCK	3	3000	179.0	8.4	2.4	2.4	1.19	4.0	8.0	Q3
REF3320AIDCKT	SC70	DCK	3	250	179.0	8.4	2.4	2.4	1.19	4.0	8.0	Q3
REF3325AIDBZR	SOT-23	DBZ	3	3000	179.0	8.4	3.15	2.95	1.22	4.0	8.0	Q3
REF3325AIDBZT	SOT-23	DBZ	3	250	179.0	8.4	3.15	2.95	1.22	4.0	8.0	Q3
REF3325AIDCKR	SC70	DCK	3	3000	179.0	8.4	2.4	2.4	1.19	4.0	8.0	Q3
REF3325AIDCKT	SC70	DCK	3	250	179.0	8.4	2.4	2.4	1.19	4.0	8.0	Q3
REF3330AIDBZR	SOT-23	DBZ	3	3000	179.0	8.4	3.15	2.95	1.22	4.0	8.0	Q3
REF3330AIDBZT	SOT-23	DBZ	3	250	179.0	8.4	3.15	2.95	1.22	4.0	8.0	Q3

Device	Package Type	Package Drawing	Pins	SPQ	Reel Diameter (mm)	Reel Width W1 (mm)	A0 (mm)	B0 (mm)	K0 (mm)	P1 (mm)	W (mm)	Pin1 Quadrant
REF3330AIDCKR	SC70	DCK	3	3000	179.0	8.4	2.4	2.4	1.19	4.0	8.0	Q3
REF3330AIDCKT	SC70	DCK	3	250	179.0	8.4	2.4	2.4	1.19	4.0	8.0	Q3
REF3333AIDBZR	SOT-23	DBZ	3	3000	179.0	8.4	3.15	2.95	1.22	4.0	8.0	Q3
REF3333AIDBZT	SOT-23	DBZ	3	250	179.0	8.4	3.15	2.95	1.22	4.0	8.0	Q3
REF3333AIDCKR	SC70	DCK	3	3000	179.0	8.4	2.4	2.4	1.19	4.0	8.0	Q3
REF3333AIDCKT	SC70	DCK	3	250	179.0	8.4	2.4	2.4	1.19	4.0	8.0	Q3

TAPE AND REEL BOX DIMENSIONS

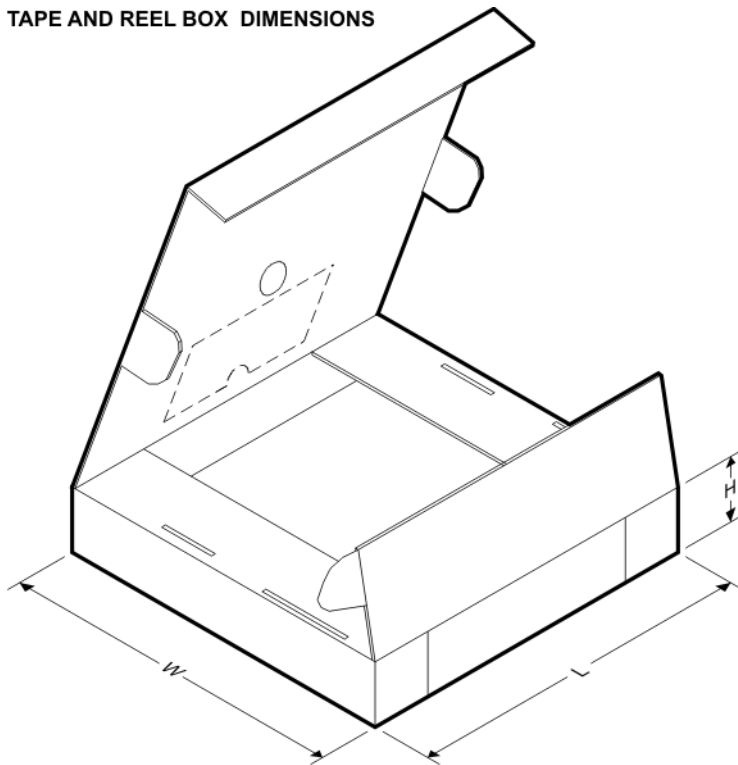

*All dimensions are nominal

Device	Package Type	Package Drawing	Pins	SPQ	Length (mm)	Width (mm)	Height (mm)
REF3312AIDBZR	SOT-23	DBZ	3	3000	195.0	200.0	45.0
REF3312AIDBZT	SOT-23	DBZ	3	250	195.0	200.0	45.0
REF3312AIDCKR	SC70	DCK	3	3000	195.0	200.0	45.0
REF3312AIDCKT	SC70	DCK	3	250	195.0	200.0	45.0
REF3318AIDBZR	SOT-23	DBZ	3	3000	195.0	200.0	45.0
REF3318AIDBZT	SOT-23	DBZ	3	250	195.0	200.0	45.0
REF3318AIDCKR	SC70	DCK	3	3000	195.0	200.0	45.0
REF3318AIDCKT	SC70	DCK	3	250	195.0	200.0	45.0
REF3320AIDBZR	SOT-23	DBZ	3	3000	195.0	200.0	45.0
REF3320AIDBZT	SOT-23	DBZ	3	250	195.0	200.0	45.0
REF3320AIDCKR	SC70	DCK	3	3000	195.0	200.0	45.0

Device	Package Type	Package Drawing	Pins	SPQ	Length (mm)	Width (mm)	Height (mm)
REF3320AIDCKT	SC70	DCK	3	250	195.0	200.0	45.0
REF3325AIDBZR	SOT-23	DBZ	3	3000	195.0	200.0	45.0
REF3325AIDBZT	SOT-23	DBZ	3	250	195.0	200.0	45.0
REF3325AIDCKR	SC70	DCK	3	3000	195.0	200.0	45.0
REF3325AIDCKT	SC70	DCK	3	250	195.0	200.0	45.0
REF3330AIDBZR	SOT-23	DBZ	3	3000	195.0	200.0	45.0
REF3330AIDBZT	SOT-23	DBZ	3	250	195.0	200.0	45.0
REF3330AIDCKR	SC70	DCK	3	3000	195.0	200.0	45.0
REF3330AIDCKT	SC70	DCK	3	250	195.0	200.0	45.0
REF3333AIDBZR	SOT-23	DBZ	3	3000	195.0	200.0	45.0
REF3333AIDBZT	SOT-23	DBZ	3	250	195.0	200.0	45.0
REF3333AIDCKR	SC70	DCK	3	3000	195.0	200.0	45.0
REF3333AIDCKT	SC70	DCK	3	250	195.0	200.0	45.0

DBZ (R-PDSO-G3)

PLASTIC SMALL-OUTLINE

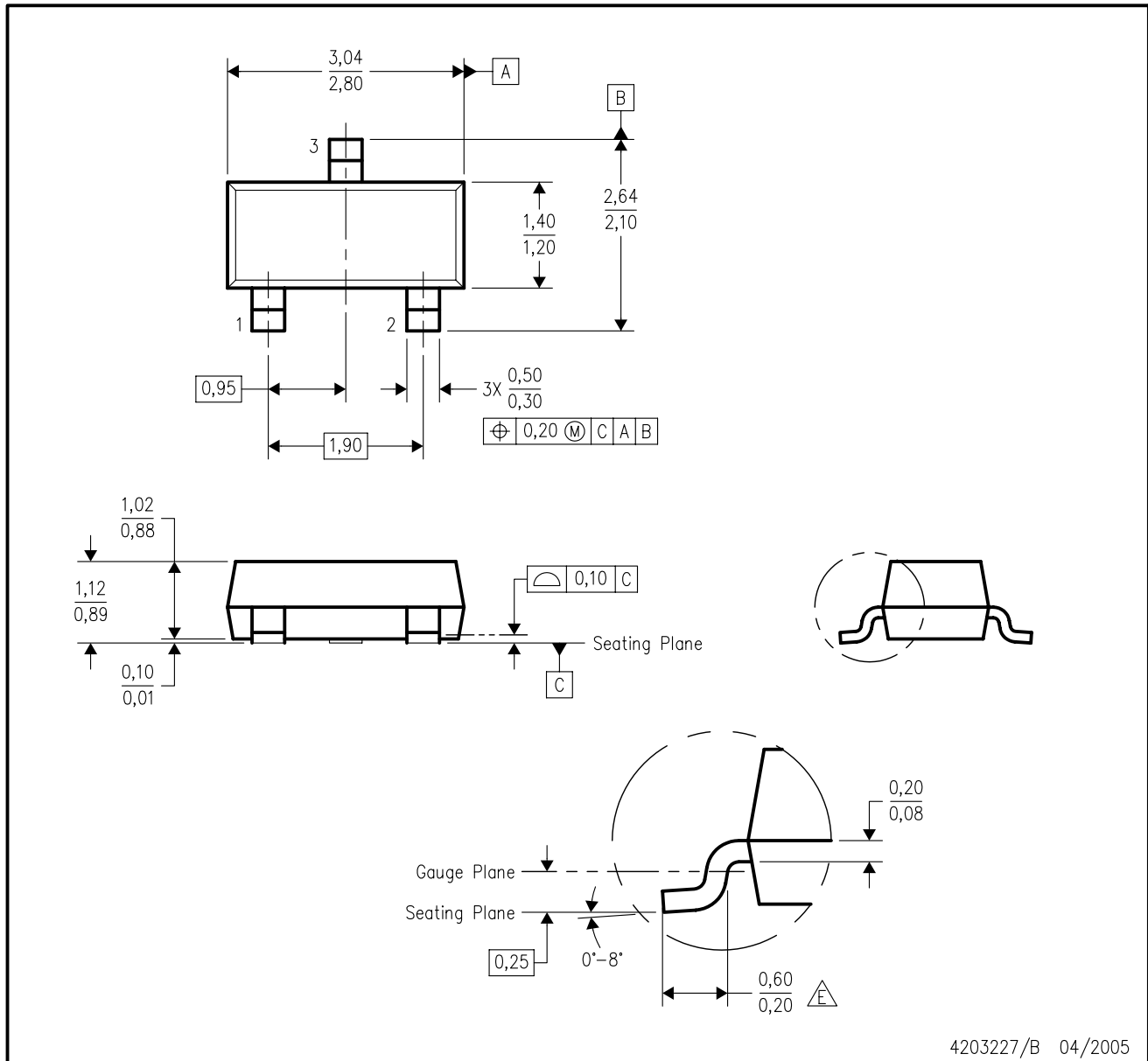

- NOTES:
- A. All linear dimensions are in millimeters. Dimensioning and tolerancing per ASME Y14.5M-1994.
 - B. This drawing is subject to change without notice.
 - C. Lead dimensions are inclusive of plating.
 - D. Body dimensions are exclusive of mold flash and protrusion. Mold flash and protrusion not to exceed 0.25 per side.
 - $\triangle E$ Falls within JEDEC TO-236 variation AB, except minimum foot length.

IMPORTANT NOTICE

Texas Instruments Incorporated and its subsidiaries (TI) reserve the right to make corrections, modifications, enhancements, improvements, and other changes to its products and services at any time and to discontinue any product or service without notice. Customers should obtain the latest relevant information before placing orders and should verify that such information is current and complete. All products are sold subject to TI's terms and conditions of sale supplied at the time of order acknowledgment.

TI warrants performance of its hardware products to the specifications applicable at the time of sale in accordance with TI's standard warranty. Testing and other quality control techniques are used to the extent TI deems necessary to support this warranty. Except where mandated by government requirements, testing of all parameters of each product is not necessarily performed.

TI assumes no liability for applications assistance or customer product design. Customers are responsible for their products and applications using TI components. To minimize the risks associated with customer products and applications, customers should provide adequate design and operating safeguards.

TI does not warrant or represent that any license, either express or implied, is granted under any TI patent right, copyright, mask work right, or other TI intellectual property right relating to any combination, machine, or process in which TI products or services are used. Information published by TI regarding third-party products or services does not constitute a license from TI to use such products or services or a warranty or endorsement thereof. Use of such information may require a license from a third party under the patents or other intellectual property of the third party, or a license from TI under the patents or other intellectual property of TI.

Reproduction of TI information in TI data books or data sheets is permissible only if reproduction is without alteration and is accompanied by all associated warranties, conditions, limitations, and notices. Reproduction of this information with alteration is an unfair and deceptive business practice. TI is not responsible or liable for such altered documentation. Information of third parties may be subject to additional restrictions.

Resale of TI products or services with statements different from or beyond the parameters stated by TI for that product or service voids all express and any implied warranties for the associated TI product or service and is an unfair and deceptive business practice. TI is not responsible or liable for any such statements.

TI products are not authorized for use in safety-critical applications (such as life support) where a failure of the TI product would reasonably be expected to cause severe personal injury or death, unless officers of the parties have executed an agreement specifically governing such use. Buyers represent that they have all necessary expertise in the safety and regulatory ramifications of their applications, and acknowledge and agree that they are solely responsible for all legal, regulatory and safety-related requirements concerning their products and any use of TI products in such safety-critical applications, notwithstanding any applications-related information or support that may be provided by TI. Further, Buyers must fully indemnify TI and its representatives against any damages arising out of the use of TI products in such safety-critical applications.

TI products are neither designed nor intended for use in military/aerospace applications or environments unless the TI products are specifically designated by TI as military-grade or "enhanced plastic." Only products designated by TI as military-grade meet military specifications. Buyers acknowledge and agree that any such use of TI products which TI has not designated as military-grade is solely at the Buyer's risk, and that they are solely responsible for compliance with all legal and regulatory requirements in connection with such use.

TI products are neither designed nor intended for use in automotive applications or environments unless the specific TI products are designated by TI as compliant with ISO/TS 16949 requirements. Buyers acknowledge and agree that, if they use any non-designated products in automotive applications, TI will not be responsible for any failure to meet such requirements.

Following are URLs where you can obtain information on other Texas Instruments products and application solutions:

Products		Applications	
Amplifiers	amplifier.ti.com	Audio	www.ti.com/audio
Data Converters	dataconverter.ti.com	Automotive	www.ti.com/automotive
DLP® Products	www.dlp.com	Communications and Telecom	www.ti.com/communications
DSP	dsp.ti.com	Computers and Peripherals	www.ti.com/computers
Clocks and Timers	www.ti.com/clocks	Consumer Electronics	www.ti.com/consumer-apps
Interface	interface.ti.com	Energy	www.ti.com/energy
Logic	logic.ti.com	Industrial	www.ti.com/industrial
Power Mgmt	power.ti.com	Medical	www.ti.com/medical
Microcontrollers	microcontroller.ti.com	Security	www.ti.com/security
RFID	www.ti-rfid.com	Space, Avionics & Defense	www.ti.com/space-avionics-defense
RF/IF and ZigBee® Solutions	www.ti.com/lprf	Video and Imaging	www.ti.com/video
		Wireless	www.ti.com/wireless-apps

Mailing Address: Texas Instruments, Post Office Box 655303, Dallas, Texas 75265
Copyright © 2010, Texas Instruments Incorporated