



10ppm/°C, 1μA, 1.25V SHUNT VOLTAGE REFERENCE

FEATURES

- MICRO-PACKAGE: SOT23-3
- WIDE CURRENT RANGE: 1μA to 5mA
- HIGH INITIAL ACCURACY: 0.2%
- EXCELLENT SPECIFIED DRIFT PERFORMANCE:
 - 30ppm/°C (max) from 0°C to +70°C
 - 50ppm/°C (max) from -40°C to +85°C

APPLICATIONS

- BATTERY-POWERED INSTRUMENTS
- PORTABLE DEVICES
- MEDICAL EQUIPMENT
- CURRENT SOURCES
- CALIBRATORS
- MICROPOWER CURRENT AND VOLTAGE REFERENCE

DESCRIPTION

The REF1112 is a two-terminal shunt reference designed for power- and space-sensitive applications. The REF1112 features an operating current of 1mA in a SOT23-3 package and is an improved, lower power solution for designs currently using voltage references in larger packages, such as the REF1004 and LT1004. The REF1112 is specified from -40°C to +85°C with operation extending from -40°C to +125°C.

The REF1112 complements other 1μA components from Texas Instruments including the OPA349 and the TLV240x low-power operational amplifiers, and the TLV349x micropower voltage comparator.

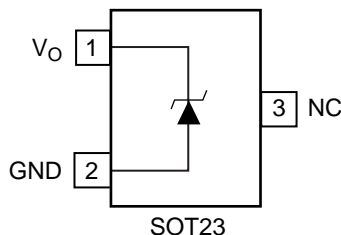
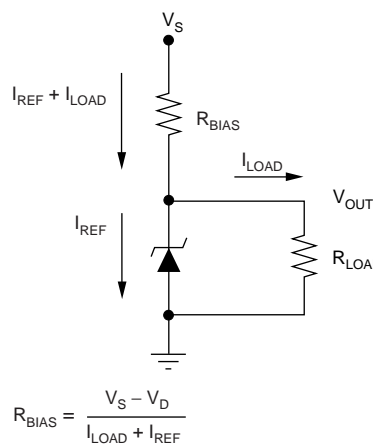

NC indicates pin should be left unconnected.



Please be aware that an important notice concerning availability, standard warranty, and use in critical applications of Texas Instruments semiconductor products and disclaimers thereto appears at the end of this data sheet.

All trademarks are the property of their respective owners.

ABSOLUTE MAXIMUM RATINGS⁽¹⁾

Reverse Breakdown Current	10mA
Forward Current	10mA
Operating Temperature	-55°C to +125°C
Storage Temperature	-65°C to +150°C
Junction Temperature	+150°C

(1) Stresses above these ratings may cause permanent damage. Exposure to absolute maximum conditions for extended periods may degrade device reliability. These are stress ratings only, and functional operation of the device at these or any other conditions beyond those specified is not implied.



ELECTROSTATIC DISCHARGE SENSITIVITY

Electrostatic discharge can cause damage ranging from performance degradation to complete device failure. Texas Instruments recommends that all integrated circuits be handled and stored using appropriate ESD protection methods.

ESD damage can range from subtle performance degradation to complete device failure. Precision integrated circuits may be more susceptible to damage because very small parametric changes could cause the device not to meet published specifications.

PACKAGE/ORDERING INFORMATION⁽¹⁾

PRODUCT	PACKAGE-LEAD	PACKAGE DESIGNATOR	SPECIFIED TEMPERATURE RANGE	PACKAGE MARKING	ORDERING NUMBER	TRANSPORT MEDIA, QUANTITY
REF1112	SOT23-3	DBZ	-40°C to +125°C	R11A	REF1112AIDBZT	Tape and Reel, 250
"	"	"	"	"	REF1112AIDBZR	Tape and Reel, 3000

NOTE: (1) For the most current package and ordering information, see the Package Option Addendum at the end of this document, or see the TI website at www.ti.com.

ELECTRICAL CHARACTERISTICS

Boldface limits apply over the specified temperature range, $T_A = -40^\circ\text{C}$ to $+125^\circ\text{C}$.

At $T_A = +25^\circ\text{C}$, $I_{REF} = 1.2\mu\text{A}$ and $C_{LOAD} = 10\text{nF}$, unless otherwise noted.

PARAMETER	CONDITIONS	REF1112 - 1.25V			UNITS
		MIN	TYP	MAX	
REVERSE BREAKDOWN VOLTAGE	$I_{REF} = 1.2\mu\text{A}$	1.2475 -0.2	1.25	1.2525 +0.2	V %
TEMPERATURE COEFFICIENT	$1.2\mu\text{A} \leq I_{REF} \leq 5\text{mA}$, 0°C to $+70^\circ\text{C}$ $1.5\mu\text{A} \leq I_{REF} \leq 5\text{mA}$, -40°C to $+85^\circ\text{C}$ $1.5\mu\text{A} \leq I_{REF} \leq 5\text{mA}$, -40°C to $+125^\circ\text{C}$		10 15 15	30 50	ppm/°C ppm/°C ppm/°C
MINIMUM OPERATING CURRENT			1	1.2	μA
REVERSE BREAKDOWN VOLTAGE CHANGE WITH CURRENT	$1.2\mu\text{A} \leq I_{REF} \leq 5\text{mA}$		30	100	ppm/mA
REVERSE DYNAMIC IMPEDANCE	$1.2\mu\text{A} \leq I_{REF} \leq 5\text{mA}$		0.037	0.125	Ω
LOW-FREQUENCY NOISE ⁽¹⁾ $0.1\text{Hz} \leq I_{REF} \leq 10\text{Hz}$			25		μV_{PP}
THERMAL HYSTERESIS ⁽²⁾			100		ppm
LONG-TERM STABILITY $+25^\circ\text{C} \pm 0.1^\circ\text{C}$			60		ppm/kHr
TEMPERATURE CHARACTERISTICS					
Specified Range		-40		+125	°C
Operating Range		-40		+125	°C
Storage Range		-40		+150	°C
Thermal Resistance SOT23-3 Surface-Mount	θ_{JA}		135		°C/W

(1) Peak-to-peak noise is measured with a 2-pole high-pass filter at 0.1Hz and a 4-pole, low-pass Chebyshev filter at 10Hz.

(2) Thermal hysteresis is defined as the change in output voltage after operating the device at $+25^\circ\text{C}$, cycling the device through the specified temperature range, and returning to $+25^\circ\text{C}$.

TYPICAL CHARACTERISTICS

At $T_A = +25^\circ\text{C}$, $I_{REF} = 10\mu\text{A}$ and $C_{LOAD} = 10\text{nF}$, unless otherwise noted.

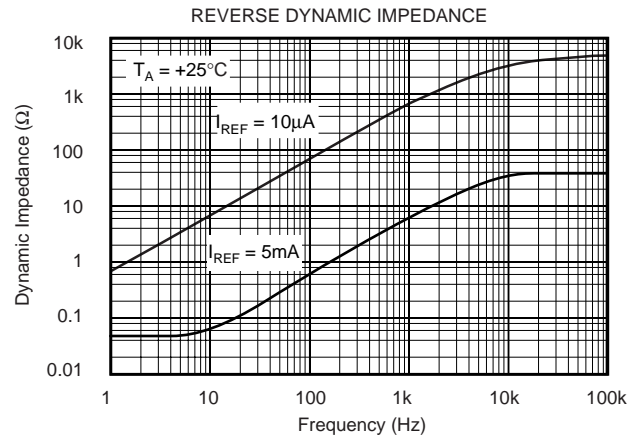
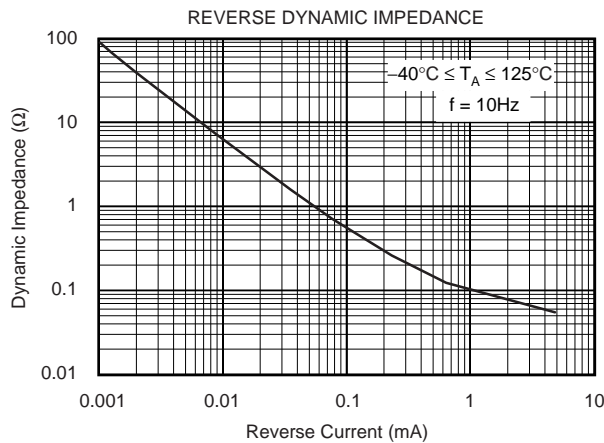
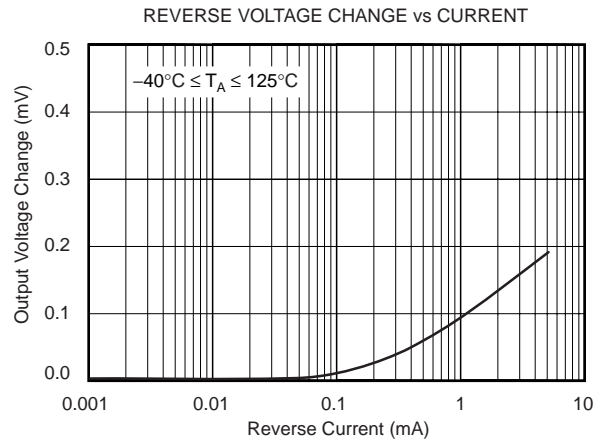
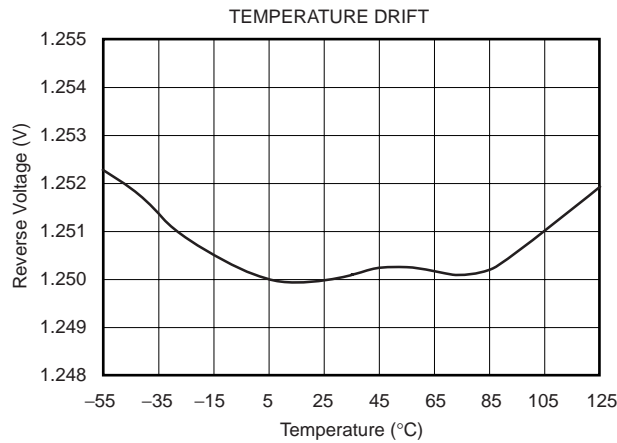
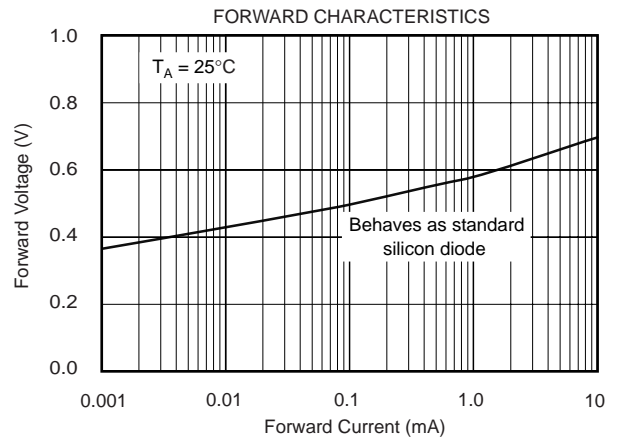
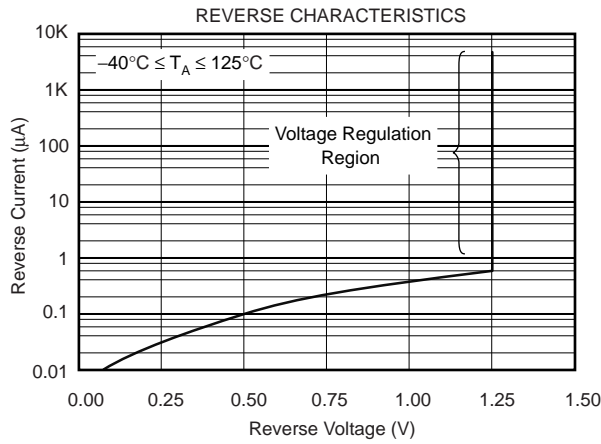

TYPICAL CHARACTERISTICS (Continued)

At $T_A = +25^\circ\text{C}$, $I_{REF} = 10\mu\text{A}$ and $C_{LOAD} = 10\text{nF}$, unless otherwise noted.

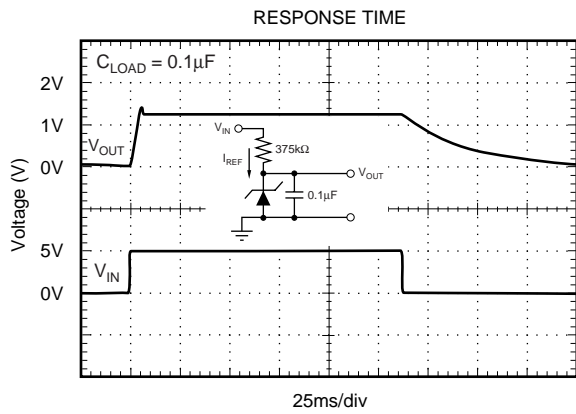
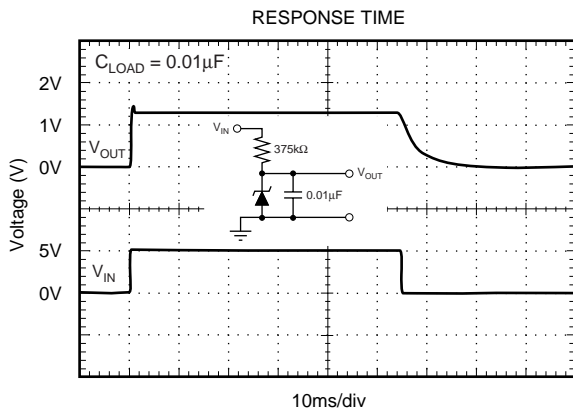
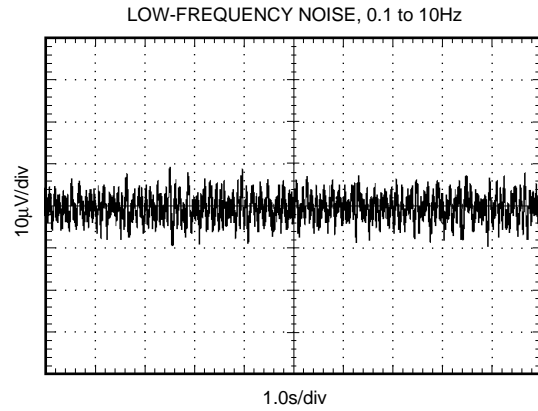
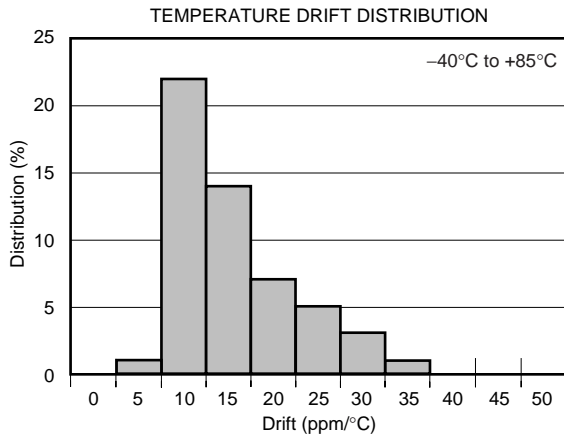
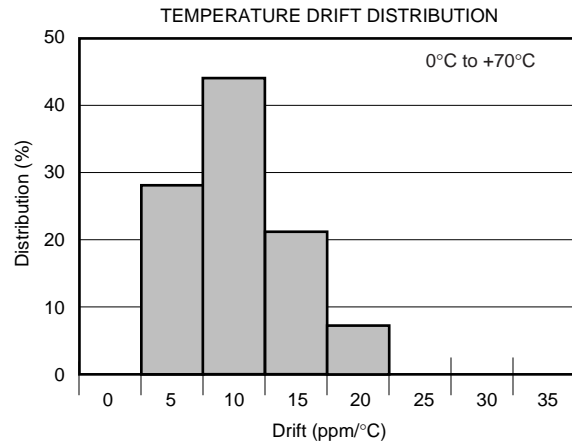
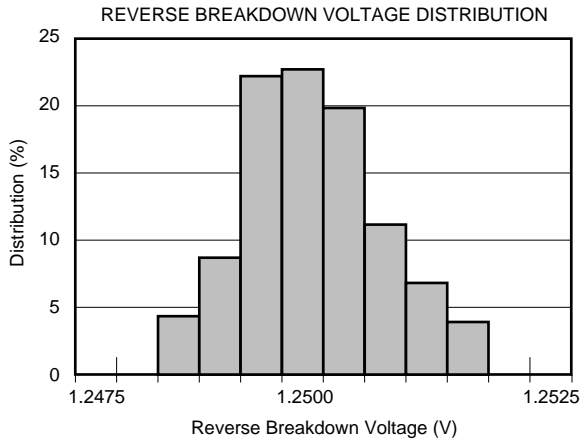

APPLICATIONS INFORMATION

The REF1112 is a two-terminal bandgap reference diode designed for high accuracy with outstanding temperature characteristics at low operating currents. Precision thin-film resistors result in 0.2% initial voltage accuracy and 50ppm/°C maximum temperature drift. The REF1112 is specified from -40°C to +85°C, with operation from -40°C to +125°C, and is offered in a SOT23-3 package.

Typical connections for the REF1112 are shown in Figure 1. A minimum 1µA bias current is required to maintain a stable output voltage and can be provided with a resistor connected to the supply voltage. I_{BIAS} depends on the values selected for R_{BIAS} and V_S , and will vary as a sum of the minimum operating current and the load current. To maintain stable operation, the value of R_{BIAS} must be low enough to maintain the minimum operating current at the minimum and maximum load and supply voltage levels.

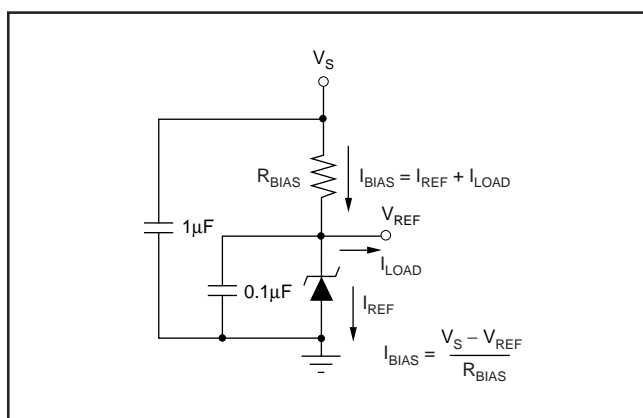

FIGURE 1. Typical Connections.

A 0.1µF load capacitor is recommended to maintain stability under varying load conditions. A minimum 0.01µF load capacitor is required for stable operation. Start-up time for the REF1112 will be affected, depending on the value of load capacitance and the bias currents being used. A 1µF power-supply bypass capacitor is recommended to minimize supply noise within the circuit.

The REF1112 shunt voltage reference provides a versatile function for low power and space-conservative applications. The REF1112 can be configured with an additional diode and NPN transistor to provide a temperature compensated current reference as shown in Figure 2. The REF1112 can be scaled to provide extremely low power reference voltages. Figure 3 shows the REF1112 used as a 1V out, 3µA voltage reference, and in Figure 4 as a 2.5V reference on 1µA.

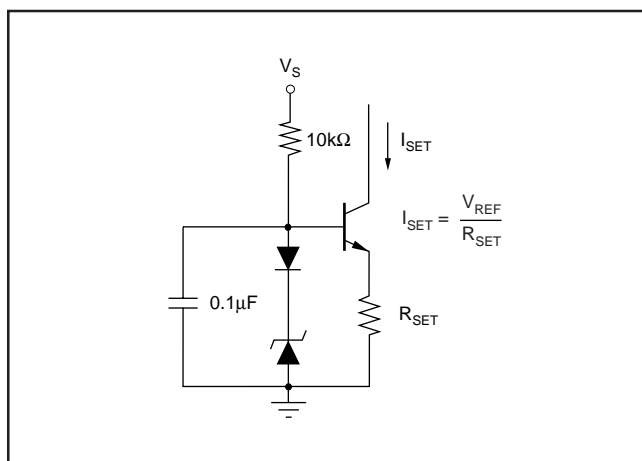

FIGURE 2. REF1112 Provides a Stable Current Source.

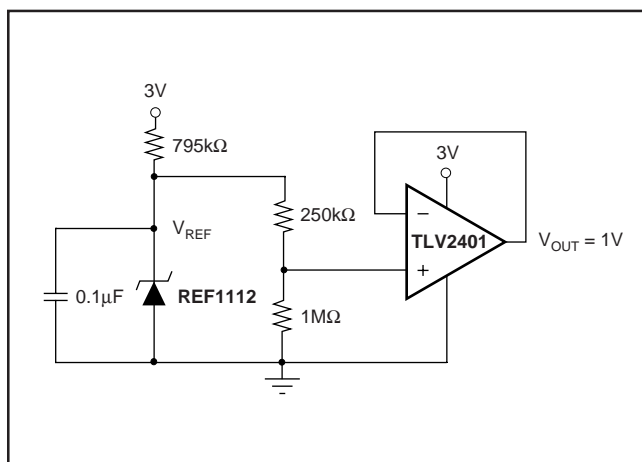

FIGURE 3. MicroPOWER 3µA 1V Voltage Reference.

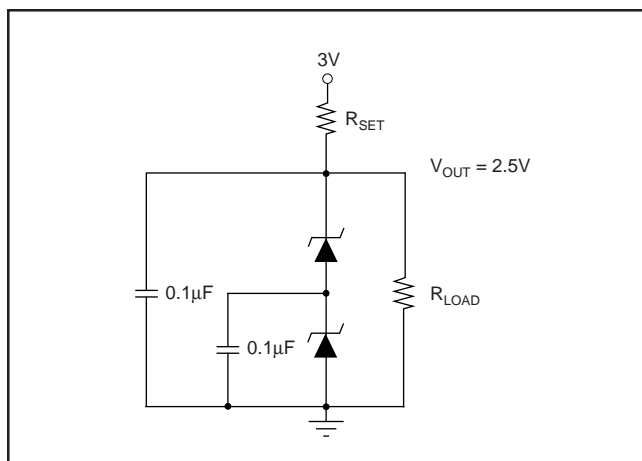

FIGURE 4. 2.5V Reference on 1µA.

For applications requiring a stable voltage reference capable of sinking higher than 5mA of current, a REF1112 combined with an OPA347 can sink up to 10mA of current. This configuration is shown in Figure 5, and through appropriate selection of R1 and R2, can be used to provide a wide range of stable reference voltages. The REF1112 is also useful for level shifting, and as shown in Figure 6, can be used to achieve the full input range of an analog-to-digital converter (ADC).

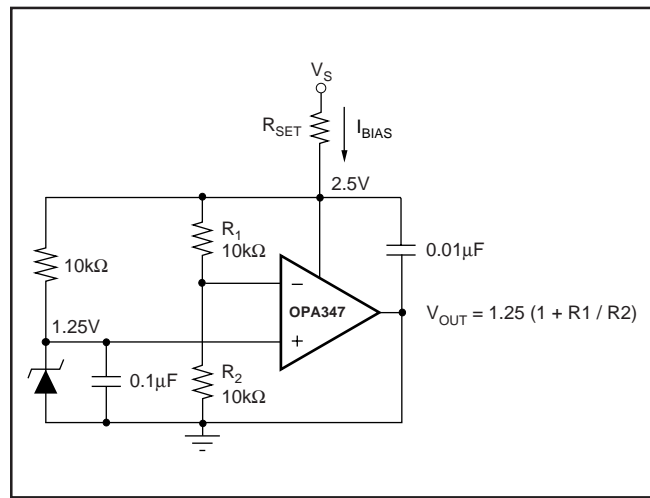

FIGURE 5. Adjustable Voltage Shunt Reference.

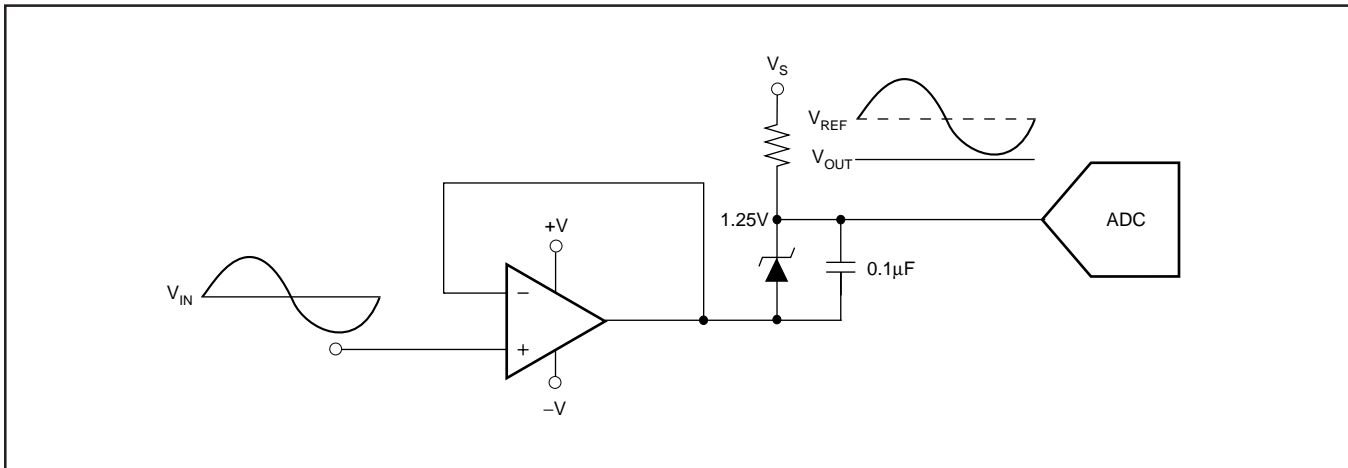

FIGURE 6. REF1112 Provides a Level Shift to Achieve Full ADC Input Range.

PACKAGING INFORMATION

Orderable Device	Status ⁽¹⁾	Package Type	Package Drawing	Pins	Package Qty	Eco Plan ⁽²⁾	Lead/Ball Finish	MSL Peak Temp ⁽³⁾
REF1112AIDBZR	ACTIVE	SOT-23	DBZ	3	3000	Green (RoHS & no Sb/Br)	CU NIPDAU	Level-1-260C-UNLIM
REF1112AIDBZRG4	ACTIVE	SOT-23	DBZ	3	3000	Green (RoHS & no Sb/Br)	CU NIPDAU	Level-1-260C-UNLIM
REF1112AIDBZT	ACTIVE	SOT-23	DBZ	3	250	Green (RoHS & no Sb/Br)	CU NIPDAU	Level-1-260C-UNLIM
REF1112AIDBZTG4	ACTIVE	SOT-23	DBZ	3	250	Green (RoHS & no Sb/Br)	CU NIPDAU	Level-1-260C-UNLIM

⁽¹⁾ The marketing status values are defined as follows:

ACTIVE: Product device recommended for new designs.

LIFEBUY: TI has announced that the device will be discontinued, and a lifetime-buy period is in effect.

NRND: Not recommended for new designs. Device is in production to support existing customers, but TI does not recommend using this part in a new design.

PREVIEW: Device has been announced but is not in production. Samples may or may not be available.

OBSOLETE: TI has discontinued the production of the device.

⁽²⁾ Eco Plan - The planned eco-friendly classification: Pb-Free (RoHS), Pb-Free (RoHS Exempt), or Green (RoHS & no Sb/Br) - please check <http://www.ti.com/productcontent> for the latest availability information and additional product content details.

TBD: The Pb-Free/Green conversion plan has not been defined.

Pb-Free (RoHS): TI's terms "Lead-Free" or "Pb-Free" mean semiconductor products that are compatible with the current RoHS requirements for all 6 substances, including the requirement that lead not exceed 0.1% by weight in homogeneous materials. Where designed to be soldered at high temperatures, TI Pb-Free products are suitable for use in specified lead-free processes.

Pb-Free (RoHS Exempt): This component has a RoHS exemption for either 1) lead-based flip-chip solder bumps used between the die and package, or 2) lead-based die adhesive used between the die and leadframe. The component is otherwise considered Pb-Free (RoHS compatible) as defined above.

Green (RoHS & no Sb/Br): TI defines "Green" to mean Pb-Free (RoHS compatible), and free of Bromine (Br) and Antimony (Sb) based flame retardants (Br or Sb do not exceed 0.1% by weight in homogeneous material)

⁽³⁾ MSL, Peak Temp. -- The Moisture Sensitivity Level rating according to the JEDEC industry standard classifications, and peak solder temperature.

Important Information and Disclaimer:The information provided on this page represents TI's knowledge and belief as of the date that it is provided. TI bases its knowledge and belief on information provided by third parties, and makes no representation or warranty as to the accuracy of such information. Efforts are underway to better integrate information from third parties. TI has taken and continues to take reasonable steps to provide representative and accurate information but may not have conducted destructive testing or chemical analysis on incoming materials and chemicals. TI and TI suppliers consider certain information to be proprietary, and thus CAS numbers and other limited information may not be available for release.

In no event shall TI's liability arising out of such information exceed the total purchase price of the TI part(s) at issue in this document sold by TI to Customer on an annual basis.

TAPE AND REEL INFORMATION

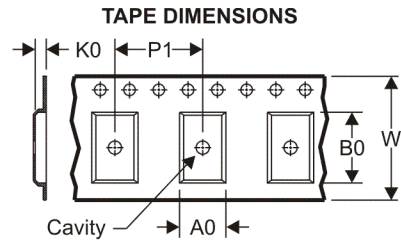
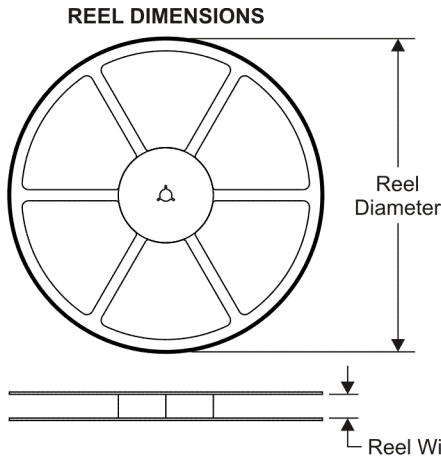

A0	Dimension designed to accommodate the component width
B0	Dimension designed to accommodate the component length
K0	Dimension designed to accommodate the component thickness
W	Overall width of the carrier tape
P1	Pitch between successive cavity centers

QUADRANT ASSIGNMENTS FOR PIN 1 ORIENTATION IN TAPE

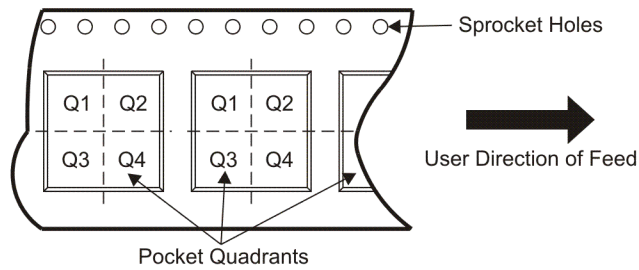

*All dimensions are nominal

Device	Package Type	Package Drawing	Pins	SPQ	Reel Diameter (mm)	Reel Width W1 (mm)	A0 (mm)	B0 (mm)	K0 (mm)	P1 (mm)	W (mm)	Pin1 Quadrant
REF1112AIDBZR	SOT-23	DBZ	3	3000	180.0	8.4	3.15	2.77	1.22	4.0	8.0	Q3
REF1112AIDBZT	SOT-23	DBZ	3	250	180.0	8.4	3.15	2.77	1.22	4.0	8.0	Q3

TAPE AND REEL BOX DIMENSIONS



*All dimensions are nominal

Device	Package Type	Package Drawing	Pins	SPQ	Length (mm)	Width (mm)	Height (mm)
REF1112AIDBZR	SOT-23	DBZ	3	3000	214.0	199.0	55.0
REF1112AIDBZT	SOT-23	DBZ	3	250	214.0	199.0	55.0

DBZ (R-PDSO-G3)

PLASTIC SMALL-OUTLINE

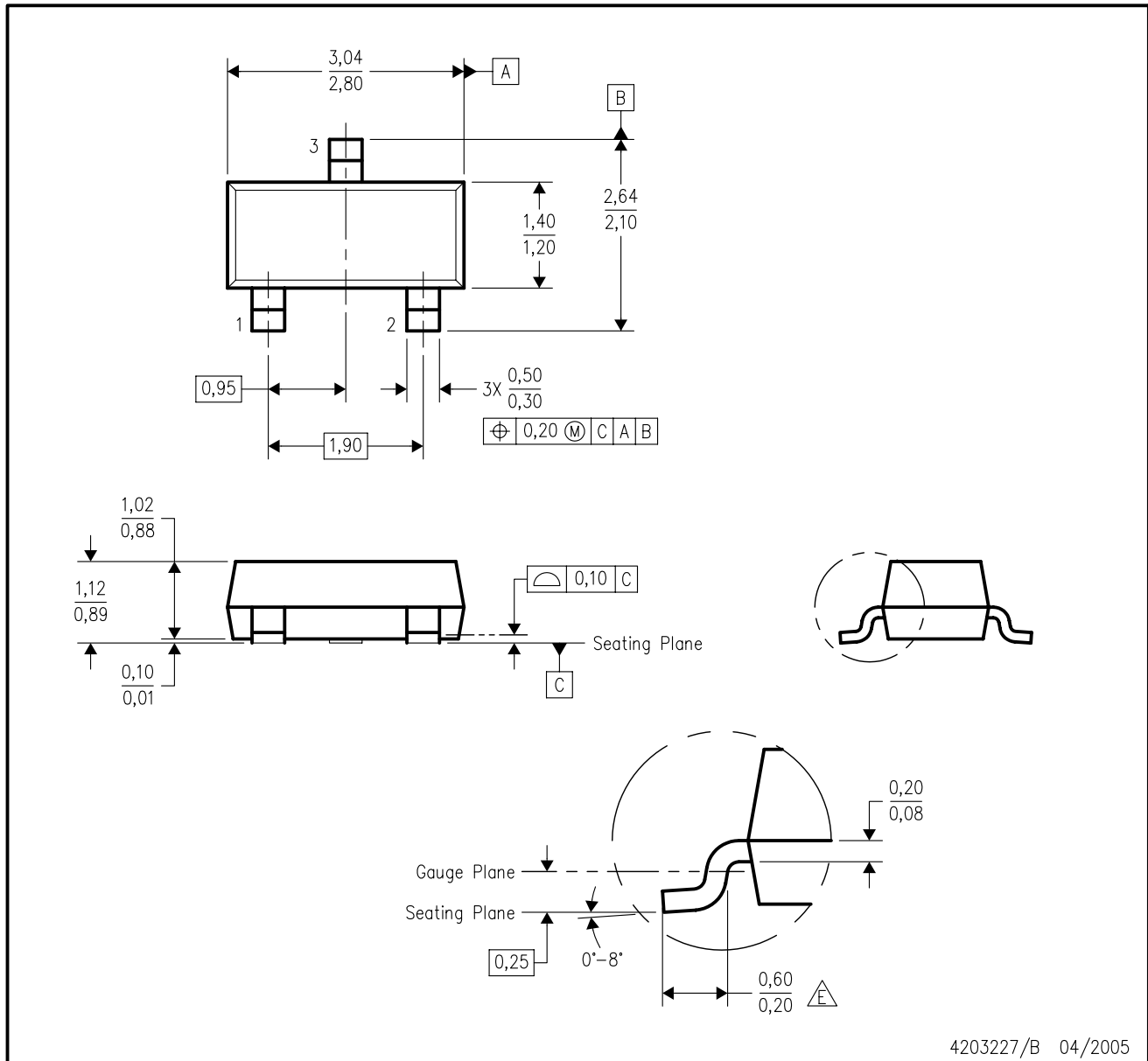

- NOTES:
- A. All linear dimensions are in millimeters. Dimensioning and tolerancing per ASME Y14.5M-1994.
 - B. This drawing is subject to change without notice.
 - C. Lead dimensions are inclusive of plating.
 - D. Body dimensions are exclusive of mold flash and protrusion. Mold flash and protrusion not to exceed 0.25 per side.
 - E. Falls within JEDEC TO-236 variation AB, except minimum foot length.

DBZ (R-PDSO-G3)

PLASTIC SMALL OUTLINE

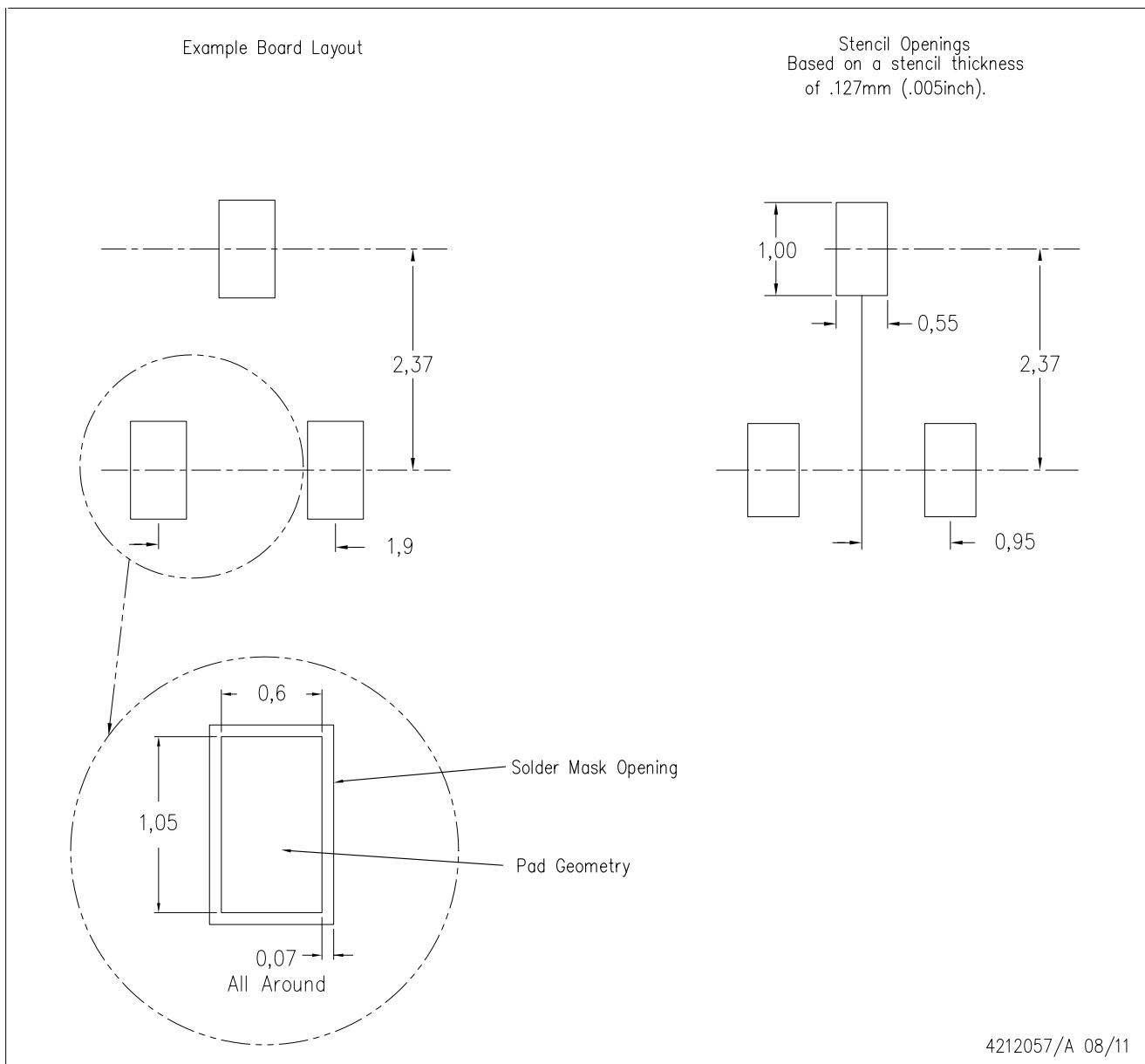

- NOTES:
- A. All linear dimensions are in millimeters.
 - B. This drawing is subject to change without notice.
 - C. Customers should place a note on the circuit board fabrication drawing not to alter the center solder mask defined pad.
 - D. Publication IPC-7351 is recommended for alternate designs.
 - E. Laser cutting apertures with trapezoidal walls and also rounding corners will offer better paste release. Customers should contact their board assembly site for stencil design recommendations. Example stencil design based on a 50% volumetric metal load solder paste. Refer to IPC-7525 for other stencil recommendations.

IMPORTANT NOTICE

Texas Instruments Incorporated and its subsidiaries (TI) reserve the right to make corrections, modifications, enhancements, improvements, and other changes to its products and services at any time and to discontinue any product or service without notice. Customers should obtain the latest relevant information before placing orders and should verify that such information is current and complete. All products are sold subject to TI's terms and conditions of sale supplied at the time of order acknowledgment.

TI warrants performance of its hardware products to the specifications applicable at the time of sale in accordance with TI's standard warranty. Testing and other quality control techniques are used to the extent TI deems necessary to support this warranty. Except where mandated by government requirements, testing of all parameters of each product is not necessarily performed.

TI assumes no liability for applications assistance or customer product design. Customers are responsible for their products and applications using TI components. To minimize the risks associated with customer products and applications, customers should provide adequate design and operating safeguards.

TI does not warrant or represent that any license, either express or implied, is granted under any TI patent right, copyright, mask work right, or other TI intellectual property right relating to any combination, machine, or process in which TI products or services are used. Information published by TI regarding third-party products or services does not constitute a license from TI to use such products or services or a warranty or endorsement thereof. Use of such information may require a license from a third party under the patents or other intellectual property of the third party, or a license from TI under the patents or other intellectual property of TI.

Reproduction of TI information in TI data books or data sheets is permissible only if reproduction is without alteration and is accompanied by all associated warranties, conditions, limitations, and notices. Reproduction of this information with alteration is an unfair and deceptive business practice. TI is not responsible or liable for such altered documentation. Information of third parties may be subject to additional restrictions.

Resale of TI products or services with statements different from or beyond the parameters stated by TI for that product or service voids all express and any implied warranties for the associated TI product or service and is an unfair and deceptive business practice. TI is not responsible or liable for any such statements.

TI products are not authorized for use in safety-critical applications (such as life support) where a failure of the TI product would reasonably be expected to cause severe personal injury or death, unless officers of the parties have executed an agreement specifically governing such use. Buyers represent that they have all necessary expertise in the safety and regulatory ramifications of their applications, and acknowledge and agree that they are solely responsible for all legal, regulatory and safety-related requirements concerning their products and any use of TI products in such safety-critical applications, notwithstanding any applications-related information or support that may be provided by TI. Further, Buyers must fully indemnify TI and its representatives against any damages arising out of the use of TI products in such safety-critical applications.

TI products are neither designed nor intended for use in military/aerospace applications or environments unless the TI products are specifically designated by TI as military-grade or "enhanced plastic." Only products designated by TI as military-grade meet military specifications. Buyers acknowledge and agree that any such use of TI products which TI has not designated as military-grade is solely at the Buyer's risk, and that they are solely responsible for compliance with all legal and regulatory requirements in connection with such use.

TI products are neither designed nor intended for use in automotive applications or environments unless the specific TI products are designated by TI as compliant with ISO/TS 16949 requirements. Buyers acknowledge and agree that, if they use any non-designated products in automotive applications, TI will not be responsible for any failure to meet such requirements.

Following are URLs where you can obtain information on other Texas Instruments products and application solutions:

Products

Audio	www.ti.com/audio
Amplifiers	amplifier.ti.com
Data Converters	dataconverter.ti.com
DLP® Products	www.dlp.com
DSP	dsp.ti.com
Clocks and Timers	www.ti.com/clocks
Interface	interface.ti.com
Logic	logic.ti.com
Power Mgmt	power.ti.com
Microcontrollers	microcontroller.ti.com
RFID	www.ti-rfid.com
RF/IF and ZigBee® Solutions	www.ti.com/lprf

Applications

Communications and Telecom	www.ti.com/communications
Computers and Peripherals	www.ti.com/computers
Consumer Electronics	www.ti.com/consumer-apps
Energy and Lighting	www.ti.com/energy
Industrial	www.ti.com/industrial
Medical	www.ti.com/medical
Security	www.ti.com/security
Space, Avionics and Defense	www.ti.com/space-avionics-defense
Transportation and Automotive	www.ti.com/automotive
Video and Imaging	www.ti.com/video
Wireless	www.ti.com/wireless-apps

TI E2E Community Home Page

e2e.ti.com

Mailing Address: Texas Instruments, Post Office Box 655303, Dallas, Texas 75265
Copyright © 2011, Texas Instruments Incorporated