

# 10V Precision Voltage Reference

## FEATURES

- **+10V  $\pm 0.0025V$  OUTPUT**
- **VERY LOW DRIFT: 2.5ppm/ $^{\circ}C$  max**
- **EXCELLENT STABILITY: 5ppm/1000hr typ**
- **EXCELLENT LINE REGULATION: 1ppm/V max**
- **EXCELLENT LOAD REGULATION: 10ppm/mA max**
- **LOW NOISE: 5 $\mu V_{PP}$  typ, 0.1Hz to 10Hz**
- **WIDE SUPPLY RANGE: 11.4VDC to 36VDC**
- **LOW QUIESCENT CURRENT: 1.4mA max**
- **PACKAGE OPTIONS: PLASTIC DIP, SO-8**

## DESCRIPTION

The REF102 is a precision 10V voltage reference. The drift is laser-trimmed to 2.5ppm/ $^{\circ}C$  max C-grade over the industrial temperature range. The REF102 achieves its precision without a heater. This results in low power, fast warm-up, excellent stability, and low noise. The output voltage is extremely insensitive to both line and load variations and can be externally adjusted with minimal effect on drift and stability. Single-supply operation from 11.4V to 36V and excellent overall specifications make the REF102 an ideal choice for demanding instrumentation and system reference applications.

## APPLICATIONS

- **PRECISION-CALIBRATED VOLTAGE STANDARD**
- **D/A AND A/D CONVERTER REFERENCE**
- **PRECISION CURRENT REFERENCE**
- **ACCURATE COMPARATOR THRESHOLD REFERENCE**
- **DIGITAL VOLTMETER**
- **TEST EQUIPMENT**
- **PC-BASED INSTRUMENTATION**

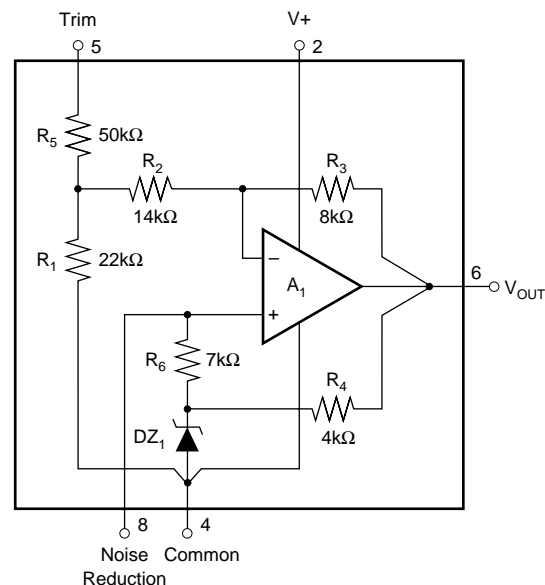

Please be aware that an important notice concerning availability, standard warranty, and use in critical applications of Texas Instruments semiconductor products and disclaimers thereto appears at the end of this data sheet.

All trademarks are the property of their respective owners.

## ABSOLUTE MAXIMUM RATINGS<sup>(1)</sup>

Input Voltage .....	+40V
Operating Temperature	
P, U .....	-25°C to +85°C
Storage Temperature Range	
P, U .....	-40°C to +125°C
Short-Circuit Protection to Common or V+ .....	Continuous

NOTE: (1) Stresses above these ratings may cause permanent damage. Exposure to absolute maximum conditions for extended periods may degrade device reliability.



## ELECTROSTATIC DISCHARGE SENSITIVITY

This integrated circuit can be damaged by ESD. Texas Instruments recommends that all integrated circuits be handled with appropriate precautions. Failure to observe proper handling and installation procedures can cause damage.

ESD damage can range from subtle performance degradation to complete device failure. Precision integrated circuits may be more susceptible to damage because very small parametric changes could cause the device not to meet its published specifications.

## PACKAGE/ORDERING INFORMATION<sup>(1)</sup>

PRODUCT	MAX INITIAL ERROR (mV)	MAX DRIFT (PPM/°C)	PACKAGE-LEAD	PACKAGE DESIGNATOR	PACKAGE MARKING
REF102AU	±10	±10	SO-8	D	REF102AU
REF102AP	±10	±10	DIP-8	P	REF102AP
REF102BU	±5	±5	SO-8	D	REF102BU
REF102BP	±5	±5	DIP-8	P	REF102BP
REF102CU	±2.5	±2.5	SO-8	D	REF102CU
REF102CP	±2.5	±2.5	DIP-8	P	REF102CP

NOTE: (1) For the most current package and ordering information, see the Package Option Addendum at the end of this data sheet, or see the TI website at [www.ti.com](http://www.ti.com).

## PIN CONFIGURATIONS

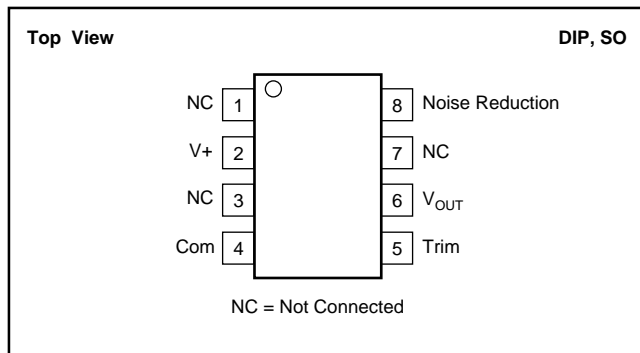

# ELECTRICAL CHARACTERISTICS

At  $T_A = +25^\circ\text{C}$  and  $V_S = +15\text{V}$  power supply, unless otherwise noted.

PARAMETER	CONDITIONS	REF102A			REF102B			REF102C			UNITS
		MIN	TYP	MAX	MIN	TYP	MAX	MIN	TYP	MAX	
<b>OUTPUT VOLTAGE</b>											
Initial	$T_A = 25^\circ\text{C}$	9.99		10.01	9.995		10.005	9.9975		10.0025	V
vs Temperature <sup>(1)</sup>				10			5			2.5	ppm/ $^\circ\text{C}$
vs Supply (Line Regulation)	$V_S = 11.4\text{V}$ to 36V			2			1			1	ppm/V
vs Output Current (Load Regulation)	$I_L = 0\text{mA}$ to +10mA			20			10			10	ppm/mA
	$I_L = 0\text{mA}$ to -5mA			40			20			20	ppm/mA
vs Time	$T_A = +25^\circ\text{C}$										
M Package			5			*			*		ppm/1000hr
P, U Packages <sup>(2)</sup>			20			*			*		ppm/1000hr
Trim Range <sup>(3)</sup>		$\pm 3$			*			*			%
Capacitive Load, max			1000		*			*			pF
<b>NOISE</b>	0.1Hz to 10Hz		5			*			*		$\mu\text{V}_{PP}$
<b>OUTPUT CURRENT</b>		+10, -5			*			*			mA
<b>INPUT VOLTAGE RANGE</b>		+11.4		+36	*		*	*		*	V
<b>QUIESCENT CURRENT</b>	$I_{OUT} = 0$			+1.4			*			*	mA
<b>WARM-UP TIME</b> <sup>(4)</sup>	To 0.1%		15			*			*		$\mu\text{s}$
<b>TEMPERATURE RANGE</b>											
Specification REF102A, B, C		-25		+85	*		*	*		*	$^\circ\text{C}$

\* Specifications same as REF102A.

NOTES: (1) The *box* method is used to specify output voltage drift vs temperature; see the Discussion of Performance section.

(2) Typically 5ppm/1000hrs after 168hr powered stabilization.

(3) Trimming the offset voltage affects drift slightly. See Installation and Operating Instructions for details.

(4) With noise reduction pin floating. See Typical Characteristics for details.

# TYPICAL CHARACTERISTICS

At  $T_A = +25^\circ\text{C}$ ,  $V_S = +15\text{V}$ , unless otherwise noted.

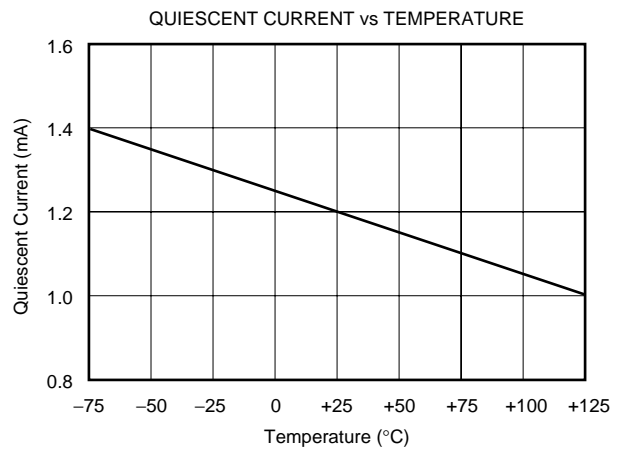
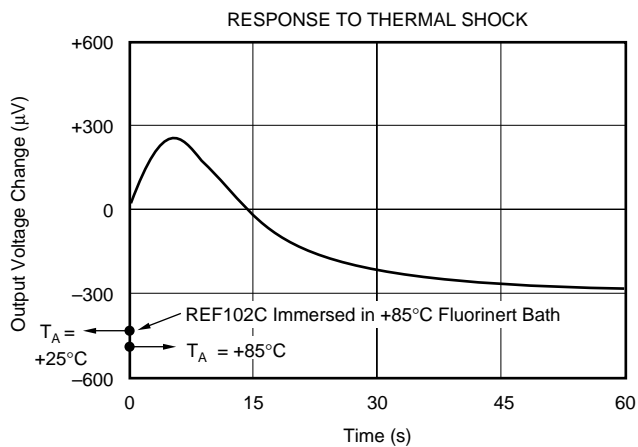
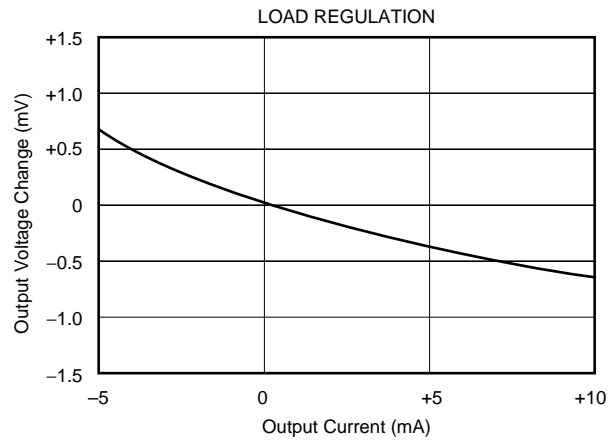
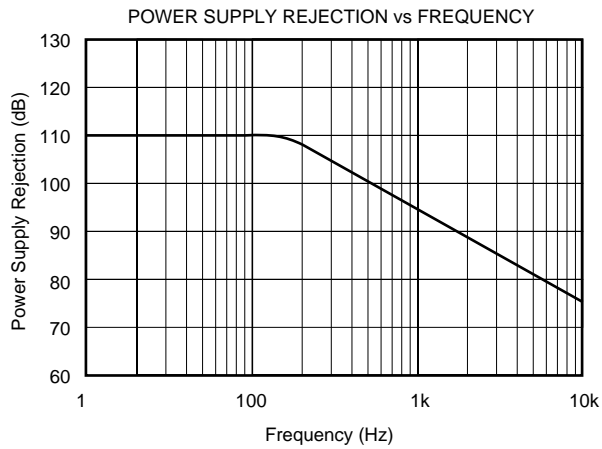
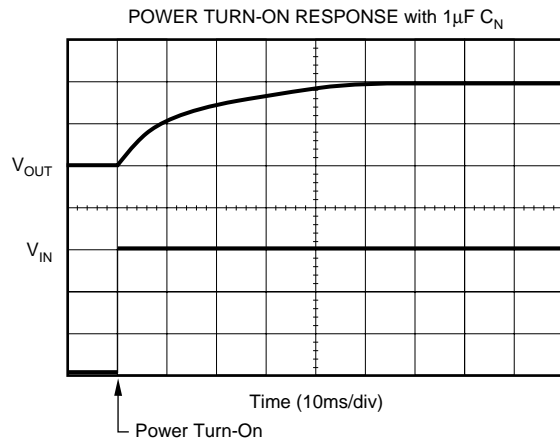
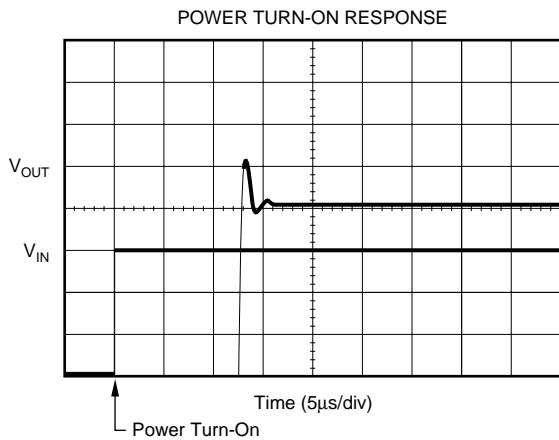

# TYPICAL CHARACTERISTICS (Cont.)

At  $T_A = +25^\circ\text{C}$ ,  $V_S = +15\text{V}$ , unless otherwise noted.

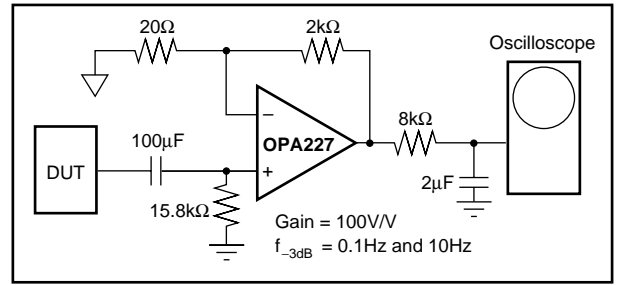
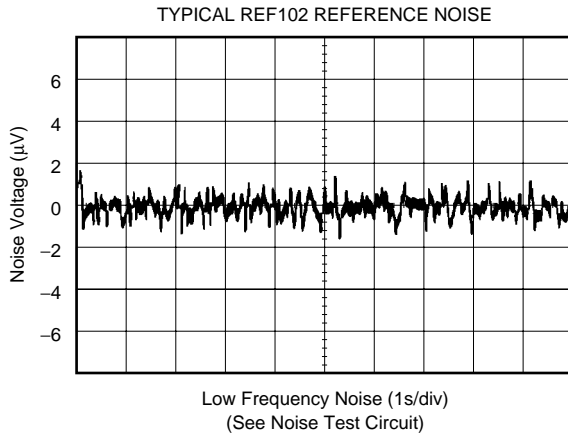

Noise Test Circuit.

## THEORY OF OPERATION

Refer to the diagram on the first page of this data sheet. The 10V output is derived from a compensated buried zener diode  $DZ_1$ , op amp  $A_1$ , and resistor network  $R_1 - R_6$ .

Approximately 8.2V is applied to the non-inverting input of  $A_1$  by  $DZ_1$ .  $R_1$ ,  $R_2$ , and  $R_3$  are laser-trimmed to produce an exact 10V output. The zener bias current is established from the regulated output voltage through  $R_4$ .  $R_5$  allows user-trimming of the output voltage by providing for small external adjustment of the amplifier gain. Because the temperature coefficient (TCR) of  $R_5$  closely matches the TCR of  $R_1$ ,  $R_2$  and  $R_3$ , the voltage trim has minimal effect on the reference drift. The output voltage noise of the REF102 is dominated by the noise of the zener diode. A capacitor can be connected between the Noise Reduction pin and ground to form a low-pass filter with  $R_6$  and roll off the high-frequency noise of the zener.

## DISCUSSION OF PERFORMANCE

The REF102 is designed for applications requiring a precision voltage reference where both the initial value at room temperature and the drift over temperature are of importance to the user. Two basic methods of specifying voltage reference drift versus temperature are in common usage in the industry—the *butterfly method* and the *box method*. The

REF102 is specified by the more commonly-used *box method*. The *box* is formed by the high and low specification temperatures and a diagonal, the slope of which is equal to the maximum specified drift.

Since the shape of the actual drift curve is not known, the vertical position of the box is not known, either. It is, however, bounded by  $V_{\text{UPPER BOUND}}$  and  $V_{\text{LOWER BOUND}}$  (see Figure 1). Figure 1 uses the REF102CU as an example. It has a drift specification of 2.5ppm/ $^\circ\text{C}$  maximum and a specification temperature range of  $-25^\circ\text{C}$  to  $+85^\circ\text{C}$ . The *box* height,  $V_1$  to  $V_2$ , is 2.75mV.

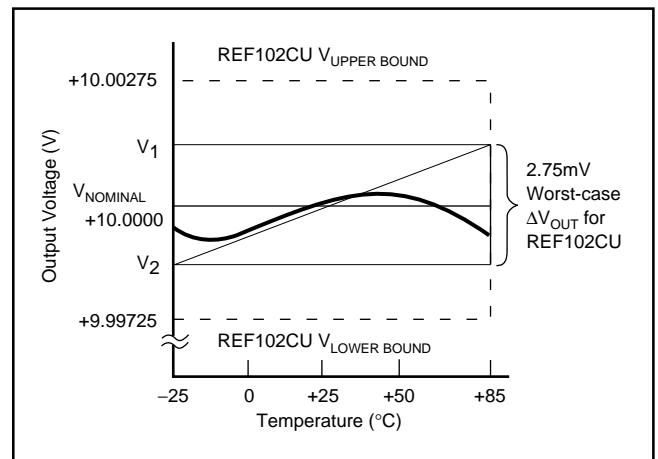

FIGURE 1. REF102CU Output Voltage Drift.

# INSTALLATION AND OPERATING INSTRUCTIONS

## BASIC CIRCUIT CONNECTION

Figure 2 shows the proper connection of the REF102. To achieve the specified performance, pay careful attention to layout. A low resistance star configuration will reduce voltage errors, noise pickup, and noise coupled from the power supply. Commons should be connected as indicated, being sure to minimize interconnection resistances.

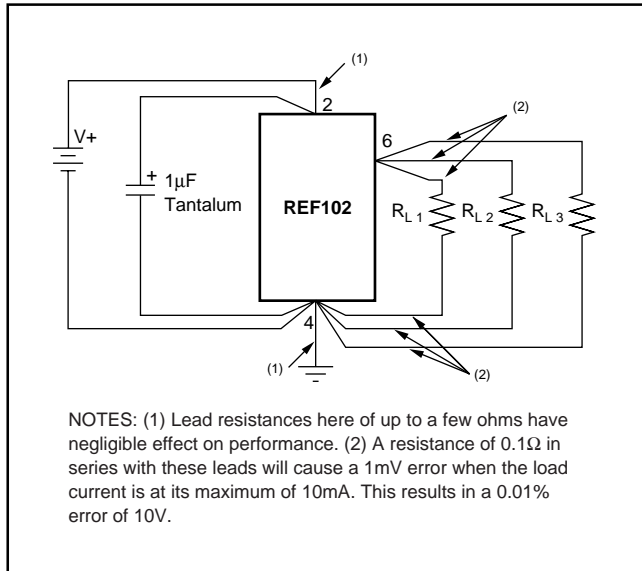

FIGURE 2. REF102 Installation.

## OPTIONAL OUTPUT VOLTAGE ADJUSTMENT

Optional output voltage adjustment circuits are shown in Figures 3 and 4. Trimming the output voltage will change the voltage drift by approximately 0.008ppm/°C per mV of trimmed voltage. In the circuit in Figure 3, any mismatch in TCR between the two sections of the potentiometer will also affect drift, but the effect of the  $\Delta$ TCR is reduced by a factor of five by the internal resistor divider. A high quality potentiometer, with good mechanical stability, such as a cermet, should be

used. The circuit in Figure 3 has a minimum trim range of  $\pm 300$ mV. The circuit in Figure 4 has less range but provides higher resolution. The mismatch in TCR between  $R_S$  and the internal resistors can introduce some slight drift. This effect is minimized if  $R_S$  is kept significantly larger than the 50kΩ internal resistor. A TCR of 100ppm/°C is normally sufficient.

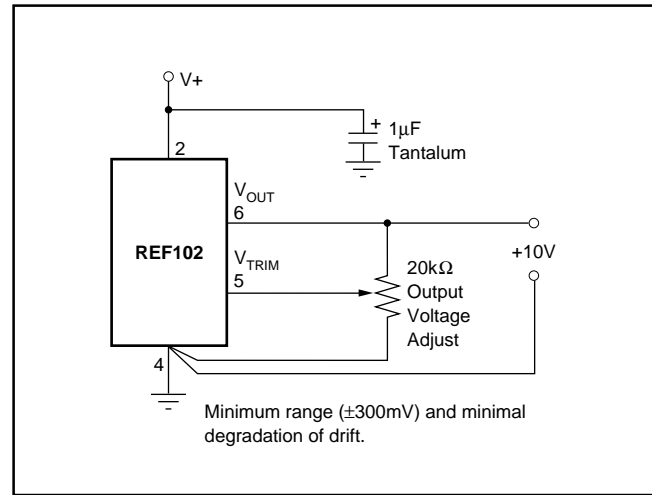

FIGURE 3. REF102 Optional Output Voltage Adjust.

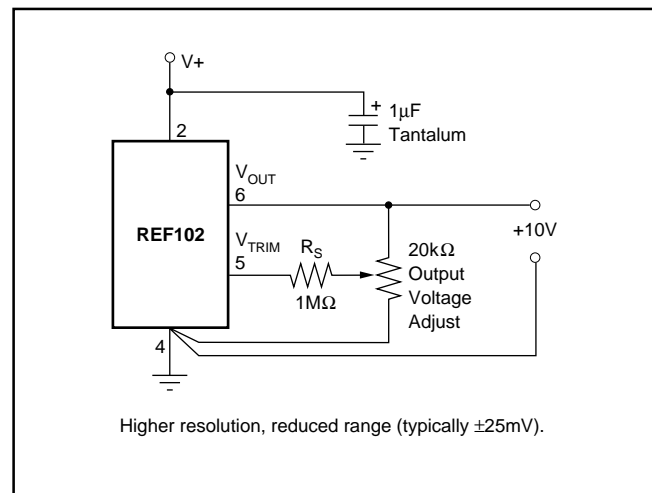

FIGURE 4. REF102 Optional Output Voltage, Fine Adjust.

## OPTIONAL NOISE REDUCTION

The high-frequency noise of the REF102 is dominated by the zener diode noise. This noise can be greatly reduced by connecting a capacitor between the Noise Reduction pin and ground. The capacitor forms a low-pass filter with  $R_6$  (refer to the figure on page 1) and attenuates the high-frequency noise generated by the zener. Figure 5 shows the effect of a  $1\mu\text{F}$  noise reduction capacitor on the high-frequency noise of the REF102.  $R_6$  is typically  $7\text{k}\Omega$  so the filter has a  $-3\text{dB}$  frequency of about  $22\text{Hz}$ . The result is a reduction in noise from about  $800\mu\text{V}_{\text{PP}}$  to under  $200\mu\text{V}_{\text{PP}}$ . If further noise reduction is required, use the circuit in Figure 14.

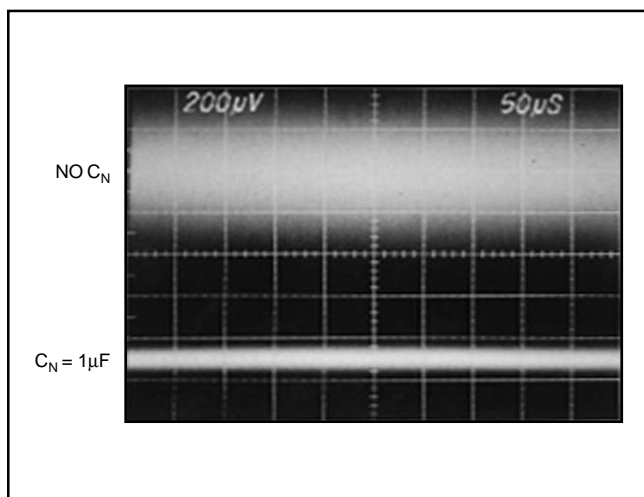

FIGURE 5. Effect of  $1\mu\text{F}$  Noise Reduction Capacitor on Broadband Noise ( $f_{-3\text{dB}} = 1\text{MHz}$ )

## APPLICATIONS INFORMATION

High accuracy, extremely low drift, outstanding stability, and low cost make the REF102 an ideal choice for all instrumentation and system reference applications. Figures 6 through 14 show a variety of useful application circuits.

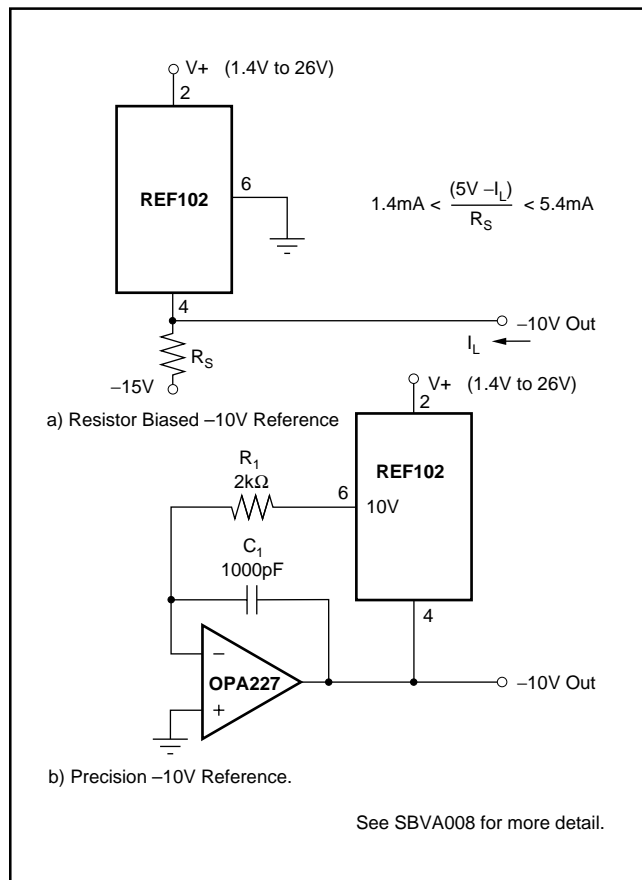

FIGURE 6.  $-10\text{V}$  Reference Using a) Resistor or b) OPA227.

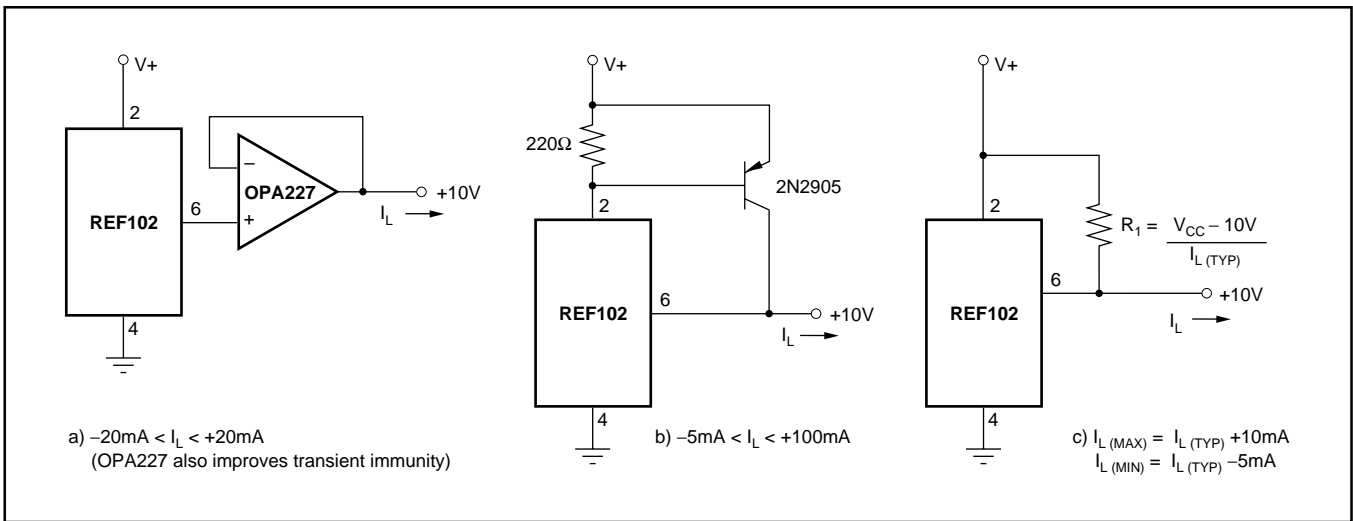

FIGURE 7. +10V Reference With Output Current Boosted to: a)  $\pm 20\text{mA}$ , b)  $+100\text{mA}$ , and c)  $I_{L(\text{TPP})} + 10\text{mA}$ ,  $-5\text{mA}$ .

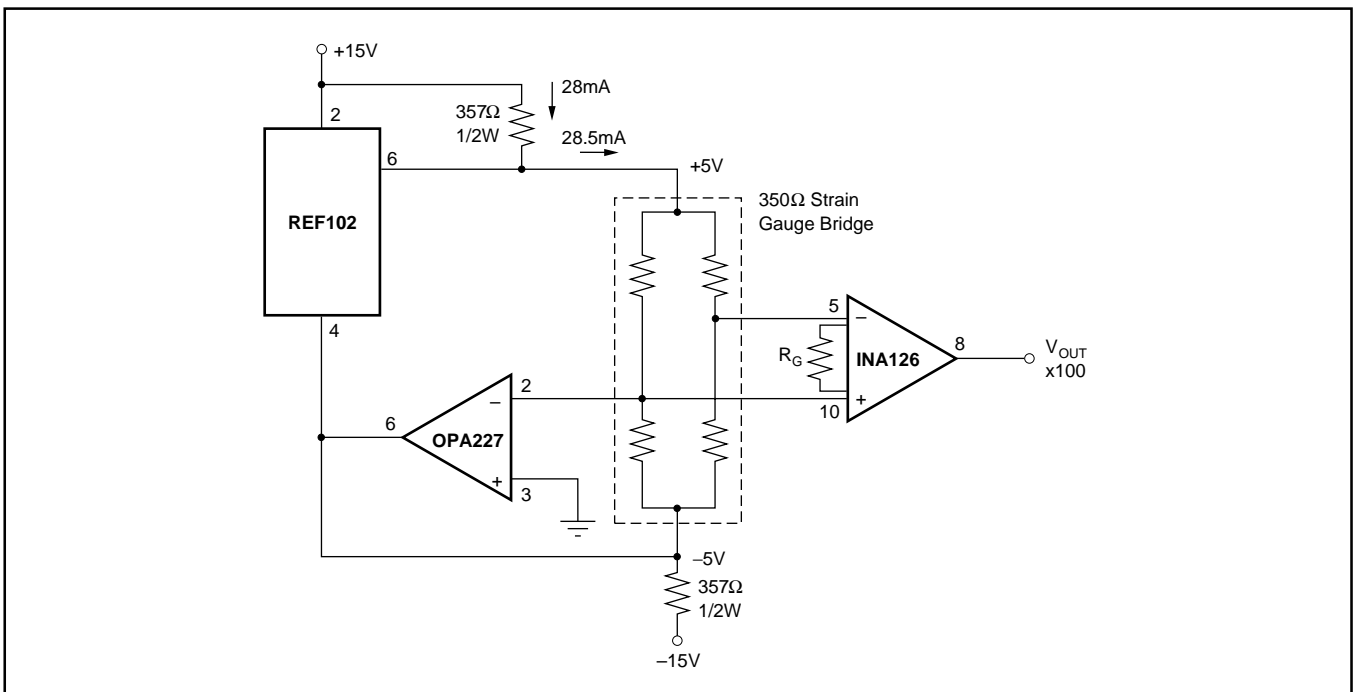

FIGURE 8. Strain Gauge Conditioner for 350Ω Bridge.

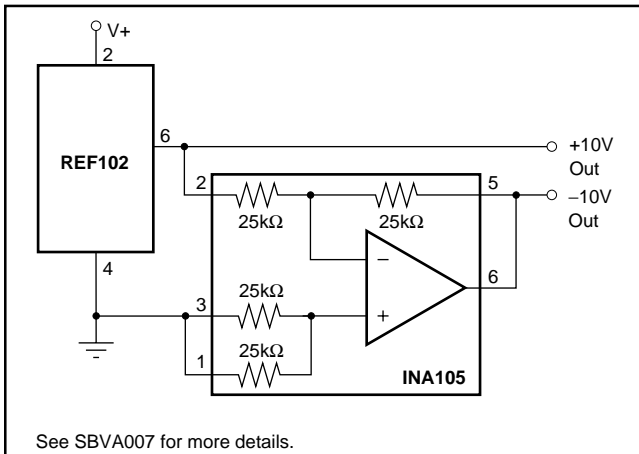

FIGURE 9.  $\pm 10\text{V}$  Reference.

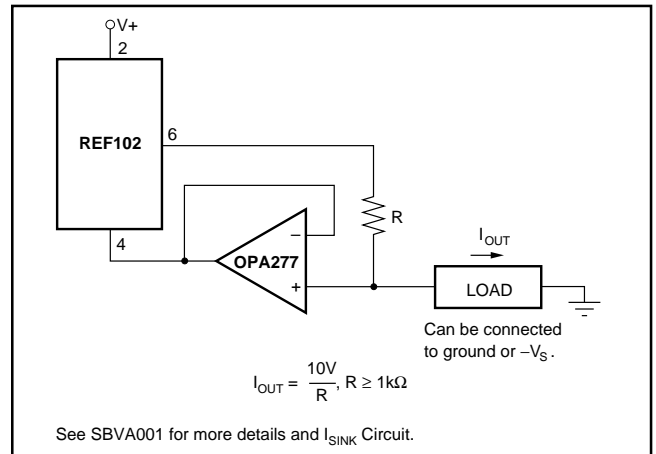

FIGURE 10. Positive Precision Current Source.

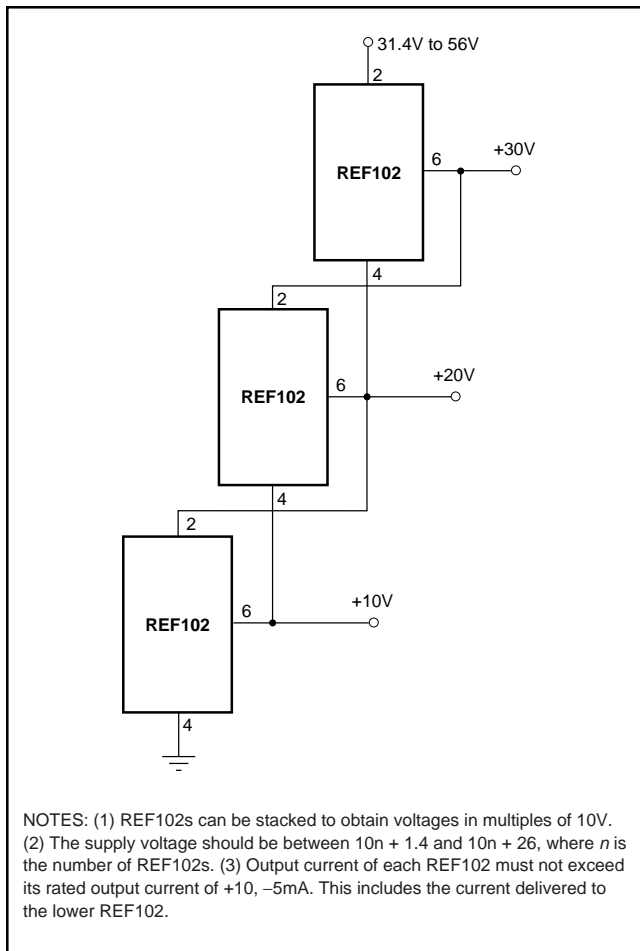

FIGURE 11. Stacked References.

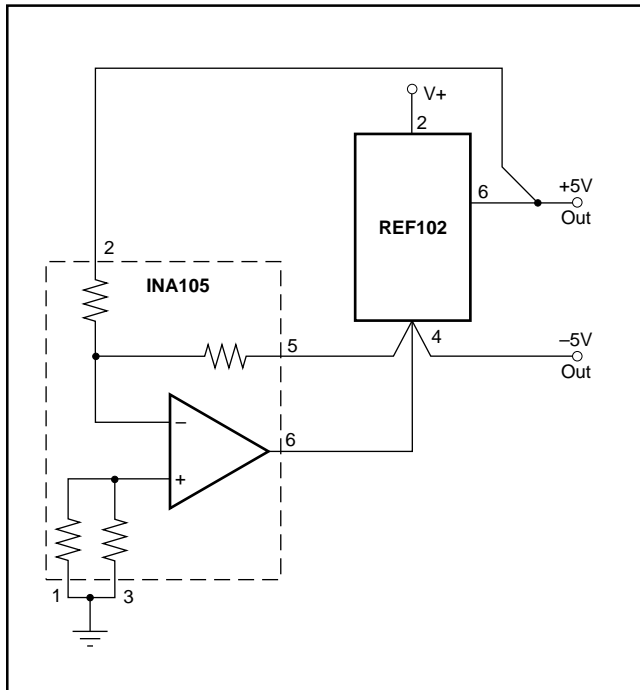

FIGURE 12.  $\pm 5V$  Reference.

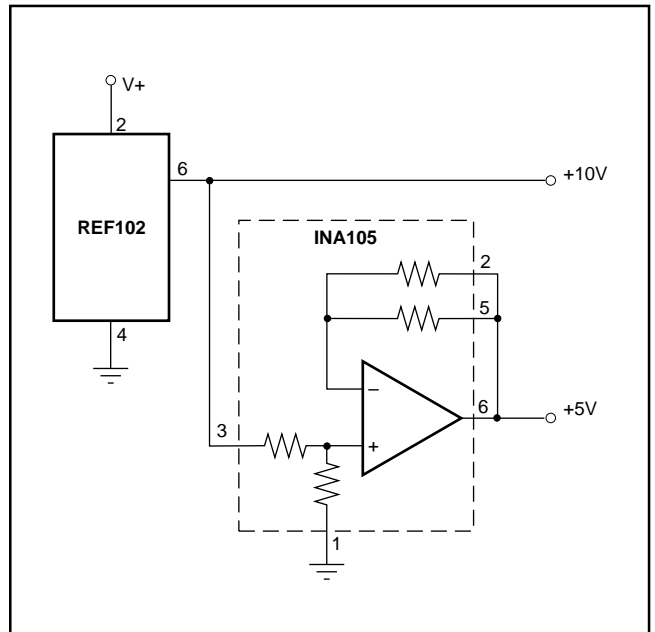

FIGURE 13. +5V and +10V Reference.

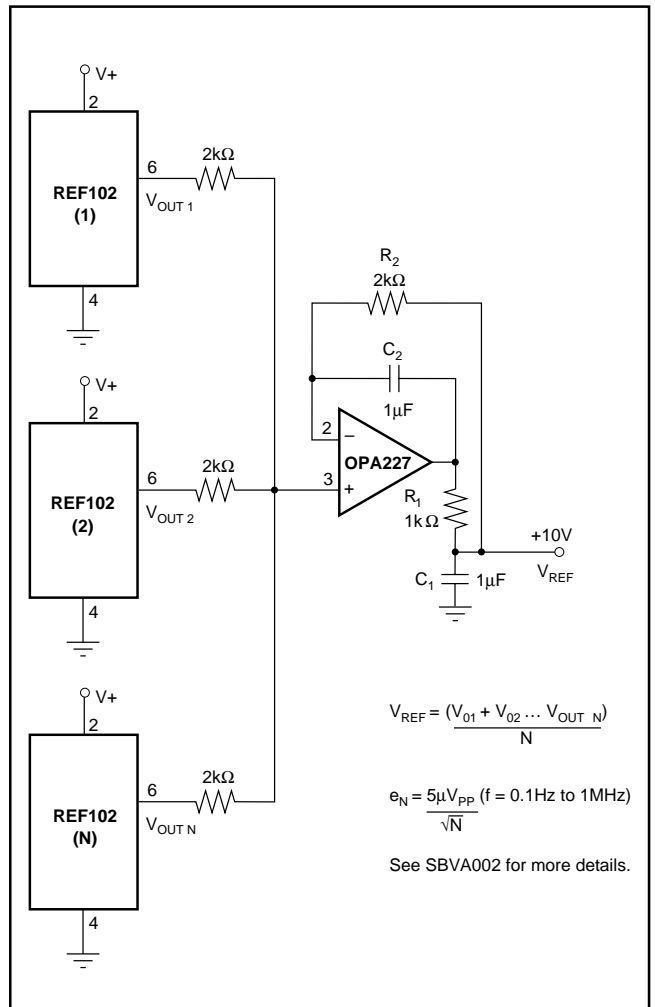

FIGURE 14. Precision Voltage Reference with Extremely Low Noise.

## Revision History

DATE	REVISION	PAGE	SECTION	DESCRIPTION
6/09	B	2	Absolute Maximum Ratings	Deleted lead temperature rating.
			Package/Ordering Information	Changed Package Ordering Information table.

NOTE: Page numbers for previous revisions may differ from page numbers in the current version.

**PACKAGING INFORMATION**

Orderable Device	Status (1)	Package Type	Package Drawing	Pins	Package Qty	Eco Plan (2)	Lead finish/ Ball material (6)	MSL Peak Temp (3)	Op Temp (°C)	Device Marking (4/5)	Samples
REF102AP	NRND	PDIP	P	8	50	RoHS & Green	NIPDAU	N / A for Pkg Type		REF102P A	
REF102AU	ACTIVE	SOIC	D	8	75	RoHS & Green	NIPDAU	Level-2-260C-1 YEAR		REF 102U A	Samples
REF102AU/2K5	ACTIVE	SOIC	D	8	2500	RoHS & Green	NIPDAU	Level-2-260C-1 YEAR		REF 102U A	Samples
REF102AUG4	ACTIVE	SOIC	D	8	75	RoHS & Green	NIPDAU	Level-2-260C-1 YEAR		REF 102U A	Samples
REF102BP	NRND	PDIP	P	8	50	RoHS & Green	Call TI	N / A for Pkg Type		REF102P B	
REF102BU	ACTIVE	SOIC	D	8	75	RoHS & Green	NIPDAU	Level-2-260C-1 YEAR	-25 to 85	REF 102U B	Samples
REF102BUG4	ACTIVE	SOIC	D	8	75	RoHS & Green	NIPDAU	Level-2-260C-1 YEAR	-25 to 85	REF 102U B	Samples
REF102CP	NRND	PDIP	P	8	50	RoHS & Green	Call TI	N / A for Pkg Type	-25 to 85	REF102P C	
REF102CPG4	NRND	PDIP	P	8	50	RoHS & Green	Call TI	N / A for Pkg Type	-25 to 85	REF102P C	
REF102CU	ACTIVE	SOIC	D	8	75	RoHS & Green	NIPDAU	Level-2-260C-1 YEAR	-25 to 85	REF 102U C	Samples
REF102CU/2K5	ACTIVE	SOIC	D	8	2500	RoHS & Green	Call TI	Level-2-260C-1 YEAR	-25 to 85	REF 102U C	Samples
REF102CUG4	ACTIVE	SOIC	D	8	75	RoHS & Green	NIPDAU	Level-2-260C-1 YEAR	-25 to 85	REF 102U C	Samples

(1) The marketing status values are defined as follows:  
**ACTIVE:** Product device recommended for new designs.

**LIFEBUY:** TI has announced that the device will be discontinued, and a lifetime-buy period is in effect.

**NRND:** Not recommended for new designs. Device is in production to support existing customers, but TI does not recommend using this part in a new design.

**PREVIEW:** Device has been announced but is not in production. Samples may or may not be available.

**OBSOLETE:** TI has discontinued the production of the device.

<sup>(2)</sup> **RoHS:** TI defines "RoHS" to mean semiconductor products that are compliant with the current EU RoHS requirements for all 10 RoHS substances, including the requirement that RoHS substance do not exceed 0.1% by weight in homogeneous materials. Where designed to be soldered at high temperatures, "RoHS" products are suitable for use in specified lead-free processes. TI may reference these types of products as "Pb-Free".

**RoHS Exempt:** TI defines "RoHS Exempt" to mean products that contain lead but are compliant with EU RoHS pursuant to a specific EU RoHS exemption.

**Green:** TI defines "Green" to mean the content of Chlorine (Cl) and Bromine (Br) based flame retardants meet JS709B low halogen requirements of  $\leq 1000$ ppm threshold. Antimony trioxide based flame retardants must also meet the  $\leq 1000$ ppm threshold requirement.

<sup>(3)</sup> MSL, Peak Temp. - The Moisture Sensitivity Level rating according to the JEDEC industry standard classifications, and peak solder temperature.

<sup>(4)</sup> There may be additional marking, which relates to the logo, the lot trace code information, or the environmental category on the device.

<sup>(5)</sup> Multiple Device Markings will be inside parentheses. Only one Device Marking contained in parentheses and separated by a "~" will appear on a device. If a line is indented then it is a continuation of the previous line and the two combined represent the entire Device Marking for that device.

<sup>(6)</sup> Lead finish/Ball material - Orderable Devices may have multiple material finish options. Finish options are separated by a vertical ruled line. Lead finish/Ball material values may wrap to two lines if the finish value exceeds the maximum column width.

**Important Information and Disclaimer:** The information provided on this page represents TI's knowledge and belief as of the date that it is provided. TI bases its knowledge and belief on information provided by third parties, and makes no representation or warranty as to the accuracy of such information. Efforts are underway to better integrate information from third parties. TI has taken and continues to take reasonable steps to provide representative and accurate information but may not have conducted destructive testing or chemical analysis on incoming materials and chemicals. TI and TI suppliers consider certain information to be proprietary, and thus CAS numbers and other limited information may not be available for release.

In no event shall TI's liability arising out of such information exceed the total purchase price of the TI part(s) at issue in this document sold by TI to Customer on an annual basis.

**TAPE AND REEL INFORMATION**

**QUADRANT ASSIGNMENTS FOR PIN 1 ORIENTATION IN TAPE**



\*All dimensions are nominal

Device	Package Type	Package Drawing	Pins	SPQ	Reel Diameter (mm)	Reel Width W1 (mm)	A0 (mm)	B0 (mm)	K0 (mm)	P1 (mm)	W (mm)	Pin1 Quadrant
REF102AU/2K5	SOIC	D	8	2500	330.0	12.4	6.4	5.2	2.1	8.0	12.0	Q1
REF102CU/2K5	SOIC	D	8	2500	330.0	12.4	6.4	5.2	2.1	8.0	12.0	Q1

**TAPE AND REEL BOX DIMENSIONS**

\*All dimensions are nominal

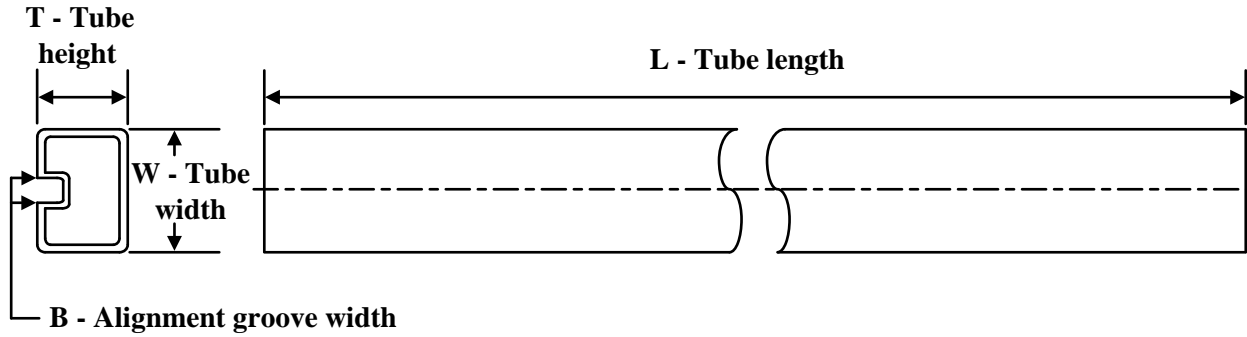
Device	Package Type	Package Drawing	Pins	SPQ	Length (mm)	Width (mm)	Height (mm)
REF102AU/2K5	SOIC	D	8	2500	356.0	356.0	35.0
REF102CU/2K5	SOIC	D	8	2500	356.0	356.0	35.0

**TUBE**

\*All dimensions are nominal

Device	Package Name	Package Type	Pins	SPQ	L (mm)	W (mm)	T (μm)	B (mm)
REF102AP	P	PDIP	8	50	506	13.97	11230	4.32
REF102AU	D	SOIC	8	75	506.6	8	3940	4.32
REF102AUG4	D	SOIC	8	75	506.6	8	3940	4.32
REF102BP	P	PDIP	8	50	506	13.97	11230	4.32
REF102BU	D	SOIC	8	75	506.6	8	3940	4.32
REF102BUG4	D	SOIC	8	75	506.6	8	3940	4.32
REF102CP	P	PDIP	8	50	506	13.97	11230	4.32
REF102CPG4	P	PDIP	8	50	506	13.97	11230	4.32
REF102CU	D	SOIC	8	75	506.6	8	3940	4.32
REF102CUG4	D	SOIC	8	75	506.6	8	3940	4.32



D0008A

# PACKAGE OUTLINE

SOIC - 1.75 mm max height

SMALL OUTLINE INTEGRATED CIRCUIT



4214825/C 02/2019

### NOTES:

1. Linear dimensions are in inches [millimeters]. Dimensions in parenthesis are for reference only. Controlling dimensions are in inches. Dimensioning and tolerancing per ASME Y14.5M.
2. This drawing is subject to change without notice.
3. This dimension does not include mold flash, protrusions, or gate burrs. Mold flash, protrusions, or gate burrs shall not exceed  $.006$  [0.15] per side.
4. This dimension does not include interlead flash.
5. Reference JEDEC registration MS-012, variation AA.

# EXAMPLE BOARD LAYOUT

D0008A

SOIC - 1.75 mm max height

SMALL OUTLINE INTEGRATED CIRCUIT



LAND PATTERN EXAMPLE  
EXPOSED METAL SHOWN  
SCALE:8X



SOLDER MASK DETAILS

4214825/C 02/2019

NOTES: (continued)

6. Publication IPC-7351 may have alternate designs.

7. Solder mask tolerances between and around signal pads can vary based on board fabrication site.

# EXAMPLE STENCIL DESIGN

D0008A

SOIC - 1.75 mm max height

SMALL OUTLINE INTEGRATED CIRCUIT



SOLDER PASTE EXAMPLE  
BASED ON .005 INCH [0.125 MM] THICK STENCIL  
SCALE:8X

4214825/C 02/2019

NOTES: (continued)

8. Laser cutting apertures with trapezoidal walls and rounded corners may offer better paste release. IPC-7525 may have alternate design recommendations.
9. Board assembly site may have different recommendations for stencil design.

P (R-PDIP-T8)

PLASTIC DUAL-IN-LINE PACKAGE



- NOTES:
- A. All linear dimensions are in inches (millimeters).
  - B. This drawing is subject to change without notice.
  - C. Falls within JEDEC MS-001 variation BA.

## IMPORTANT NOTICE AND DISCLAIMER

TI PROVIDES TECHNICAL AND RELIABILITY DATA (INCLUDING DATA SHEETS), DESIGN RESOURCES (INCLUDING REFERENCE DESIGNS), APPLICATION OR OTHER DESIGN ADVICE, WEB TOOLS, SAFETY INFORMATION, AND OTHER RESOURCES "AS IS" AND WITH ALL FAULTS, AND DISCLAIMS ALL WARRANTIES, EXPRESS AND IMPLIED, INCLUDING WITHOUT LIMITATION ANY IMPLIED WARRANTIES OF MERCHANTABILITY, FITNESS FOR A PARTICULAR PURPOSE OR NON-INFRINGEMENT OF THIRD PARTY INTELLECTUAL PROPERTY RIGHTS.

These resources are intended for skilled developers designing with TI products. You are solely responsible for (1) selecting the appropriate TI products for your application, (2) designing, validating and testing your application, and (3) ensuring your application meets applicable standards, and any other safety, security, regulatory or other requirements.

These resources are subject to change without notice. TI grants you permission to use these resources only for development of an application that uses the TI products described in the resource. Other reproduction and display of these resources is prohibited. No license is granted to any other TI intellectual property right or to any third party intellectual property right. TI disclaims responsibility for, and you will fully indemnify TI and its representatives against, any claims, damages, costs, losses, and liabilities arising out of your use of these resources.

TI's products are provided subject to [TI's Terms of Sale](#) or other applicable terms available either on [ti.com](http://ti.com) or provided in conjunction with such TI products. TI's provision of these resources does not expand or otherwise alter TI's applicable warranties or warranty disclaimers for TI products.

TI objects to and rejects any additional or different terms you may have proposed.

Mailing Address: Texas Instruments, Post Office Box 655303, Dallas, Texas 75265  
Copyright © 2022, Texas Instruments Incorporated