



# +5V Precision VOLTAGE REFERENCE

## FEATURES

- **OUTPUT VOLTAGE:** +5V  $\pm 0.2\%$  max
- **EXCELLENT TEMPERATURE STABILITY:** 10ppm/ $^{\circ}\text{C}$  max ( $-40^{\circ}\text{C}$  to  $+85^{\circ}\text{C}$ )
- **LOW NOISE:**  $10\mu\text{V}_{\text{pp}}$  max (0.1Hz to 10Hz)
- **EXCELLENT LINE REGULATION:** 0.01%/V max
- **EXCELLENT LOAD REGULATION:** 0.008%/mA max
- **LOW SUPPLY CURRENT:** 1.4mA max
- **SHORT-CIRCUIT PROTECTED**
- **WIDE SUPPLY RANGE:** 8V to 40V
- **INDUSTRIAL TEMPERATURE RANGE:**  $-40^{\circ}\text{C}$  to  $+85^{\circ}\text{C}$
- **PACKAGE OPTIONS:** DIP-8, SO-8

## APPLICATIONS

- PRECISION REGULATORS
- CONSTANT CURRENT SOURCE/SINK
- DIGITAL VOLTMETERS
- V/F CONVERTERS
- A/D AND D/A CONVERTERS
- PRECISION CALIBRATION STANDARD
- TEST EQUIPMENT

## DESCRIPTION

The REF02 is a precision 5V voltage reference. The drift is laser trimmed to 10ppm/ $^{\circ}\text{C}$  max over the extended industrial and military temperature range. The REF02 provides a stable 5V output that can be externally adjusted over a  $\pm 6\%$  range with minimal effect on temperature stability. The REF02 operates from a single supply with an input range of 8V to 40V with a very low current drain of 1mA, and excellent temperature stability due to an improved design. Excellent line and load regulation, low noise, low power, and low cost make the REF02 the best choice whenever a 5V voltage reference is required. Available package options are DIP-8 and SO-8. The REF02 is an ideal choice for portable instrumentation, temperature transducers, Analog-to-Digital (A/D) and Digital-to-Analog (D/A) converters, and digital voltmeters.

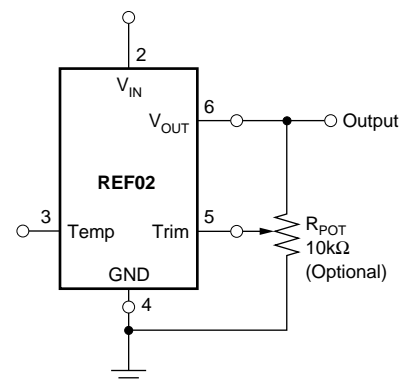

+5V Reference with Trimmed Output



Please be aware that an important notice concerning availability, standard warranty, and use in critical applications of Texas Instruments semiconductor products and disclaimers thereto appears at the end of this data sheet.

All trademarks are the property of their respective owners.

# SPECIFICATIONS

## ELECTRICAL

At  $T_A = +25^\circ\text{C}$  and  $V_{IN} = +15\text{V}$  power supply, unless otherwise noted.

PARAMETER	CONDITIONS	REF02A			REF02B			UNITS
		MIN	TYP	MAX	MIN	TYP	MAX	
<b>OUTPUT VOLTAGE</b> Change with Temperature <sup>(1, 2)</sup> ( $\Delta V_{OT}$ ) -40°C to +85°C	$I_{LOAD} = 0\text{mA}$	4.985	5.0	5.015	4.990	*	5.010	V
<b>OUTPUT VOLTAGE DRIFT<sup>(3)</sup></b> -40°C to +85°C ( $TCV_O$ )			4	15		4	10	$\pm\text{ppm}/^\circ\text{C}$
<b>LONG-TERM STABILITY</b> First 1000h Second 1000h	2000h Test		100 50			100 50		$\pm\text{ppm}$ $\pm\text{ppm}$
<b>OUTPUT ADJUSTMENT RANGE</b>	$R_{POT} = 10\text{k}\Omega^{(6)}$	$\pm 3$	$\pm 6$		*	*		%
<b>CHANGE IN <math>V_O</math> TEMP COEFFICIENT WITH OUTPUT ADJUSTMENT</b> (-55°C to +125°C)	$R_{POT} = 10\text{k}\Omega$		0.7			*		ppm/%
<b>OUTPUT VOLTAGE NOISE</b>	0.1Hz to 10Hz <sup>(5)</sup>		4	10		*	*	$\mu\text{V}_{PP}$
<b>LINE REGULATION<sup>(4)</sup></b> -40°C to +85°C	$V_{IN} = 8\text{V}$ to 33V $V_{IN} = 8.5\text{V}$ to 33V		0.006 0.008	0.010 0.012		*	*	%/V
<b>LOAD REGULATION<sup>(4)</sup></b> -40°C to +85°C	$I_L = 0\text{mA}$ to +10mA $I_L = 0\text{mA}$ to +10mA		0.005 0.007	0.010 0.012		*	0.008 0.010	%/mA
<b>TURN-ON SETTLING TIME</b>	$T_o \pm 0.1\%$ of Final Value		5			*		$\mu\text{s}$
<b>QUIESCENT CURRENT</b>	No Load		1.0	1.4		*	*	mA
<b>LOAD CURRENT (SOURCE)</b>		10	21		*	*		mA
<b>LOAD CURRENT (SINK)</b>		-0.3	-0.5		*	*		mA
<b>SHORT-CIRCUIT CURRENT</b>	$V_{OUT} = 0$		30			*		mA
<b>POWER DISSIPATION</b>	No Load		15	21		*	*	mW
<b>TEMPERATURE VOLTAGE OUTPUT<sup>(7)</sup></b>			630			*		mV
<b>TEMPERATURE COEFFICIENT</b> of Temperature Pin Voltage -55°C to +125°C			2.1					$\text{mV}/^\circ\text{C}$
<b>TEMPERATURE RANGE</b> Specification REF02A, B, C		-40		+85	*		*	$^\circ\text{C}$

NOTES: (1)  $\Delta V_{OT}$  is defined as the absolute difference between the maximum output and the minimum output voltage over the specified temperature range expressed as a percentage of 5V:

$$\Delta V_O = \left| \frac{V_{MAX} - V_{MIN}}{5V} \right| \times 100$$

(2)  $\Delta V_{OT}$  specification applies trimmed to +5.000V or untrimmed.

(3)  $TCV_O$  is defined as  $\Delta V_{OT}$  divided by the temperature range.

(4) Line and load regulation specifications include the effect of self heating.

(5) Sample tested.

(6) 10k $\Omega$  potentiometer connected between  $V_{OUT}$  and ground with wiper connected to Trim pin. See figure on page 1.

(7) Pin 3 is insensitive to capacitive loading. The temperature voltage will be modified by 7mV for each  $\mu\text{A}$  of loading.

## ABSOLUTE MAXIMUM RATINGS

Input Voltage .....	+40V
Operating Temperature	
P, U .....	-40°C to +85°C
Storage Temperature Range	
P, U .....	-65°C to +125°
Output Short Circuit Duration (to Ground or $V_{IN}$ ) .....	Indefinite
Junction Temperature .....	-65°C to +150°
$\theta_{JA}$ P .....	120°C/W
U .....	80°C/W
Lead Temperature (soldering, 60s) .....	+300°C



## ELECTROSTATIC DISCHARGE SENSITIVITY

This integrated circuit can be damaged by ESD. Texas Instruments recommends that all integrated circuits be handled with appropriate precautions. Failure to observe proper handling and installation procedures can cause damage.

ESD damage can range from subtle performance degradation to complete device failure. Precision integrated circuits may be more susceptible to damage because very small parametric changes could cause the device not to meet its published specifications.

## PIN CONFIGURATIONS

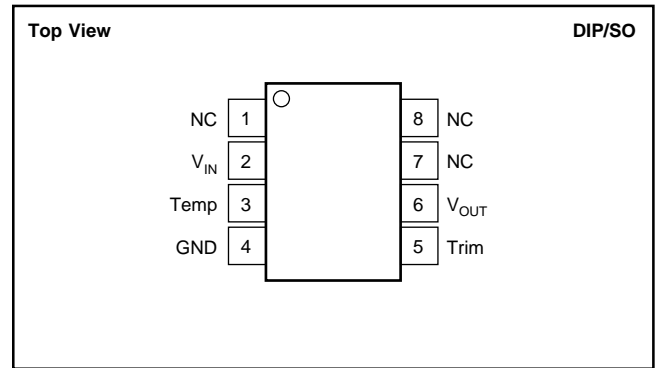

## PACKAGE/ORDERING INFORMATION<sup>(1)</sup>

PRODUCT	$V_{OUT}$ at 25°C	MAX DRIFT (ppm/°C)	PACKAGE	PACKAGE DRAWING DESIGNATOR	SPECIFICATION TEMPERATURE RANGE
REF02AU	5V±15mV	±15	SO-8	D	-40°C to +85°C
REF02BU	5V±10mV	±10	SO-8	D	-40°C to +85°C
REF02AP	5V±15mV	±15	DIP-8	P	-40°C to +85°C
REF02BP	5V±10mV	±10	DIP-8	P	-40°C to +85°C

NOTE: (1) For the most current package and ordering information, see the Package Option Addendum located at the end of this data sheet, or see the TI website at [www.ti.com](http://www.ti.com).

# TYPICAL PERFORMANCE CURVES

AT  $T_A = +25^\circ\text{C}$ , unless otherwise noted.

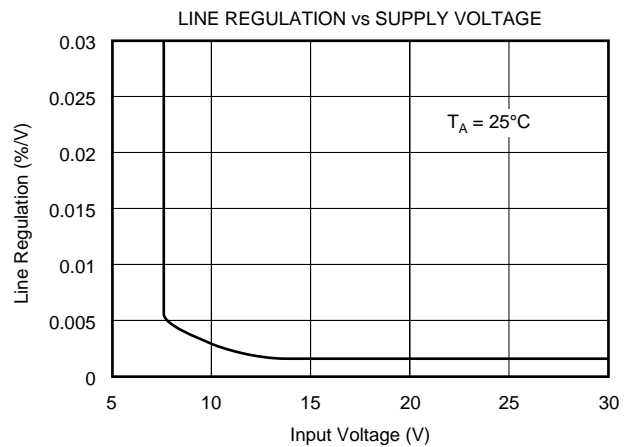
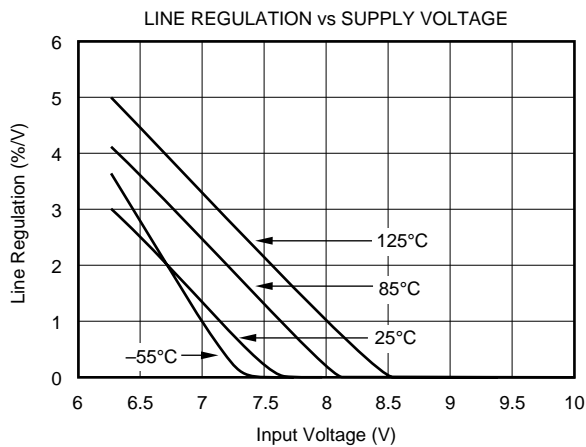
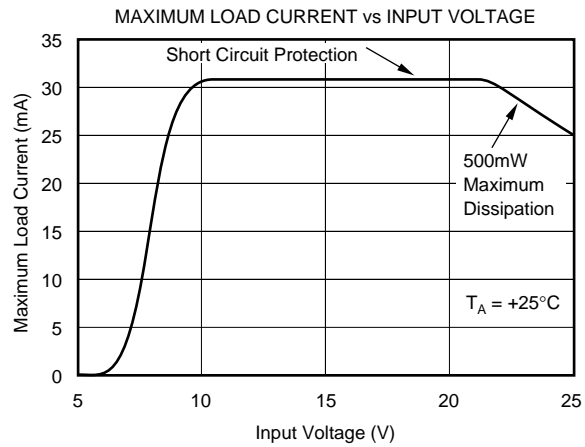
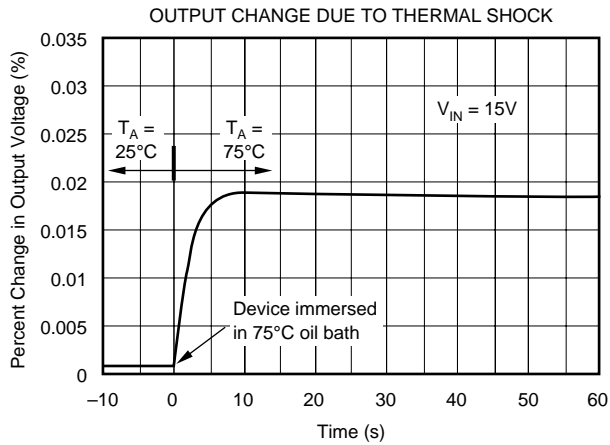
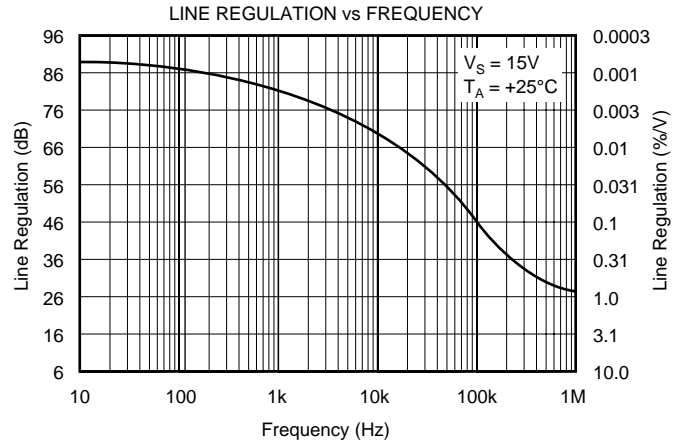
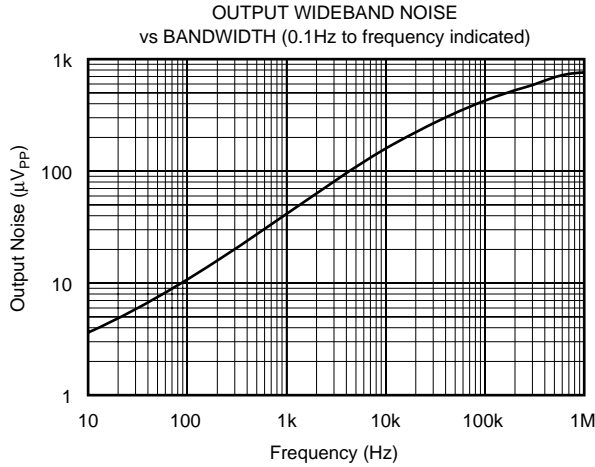

# TYPICAL PERFORMANCE CURVES (Cont.)

At  $T_A = +25^\circ\text{C}$ , unless otherwise noted.

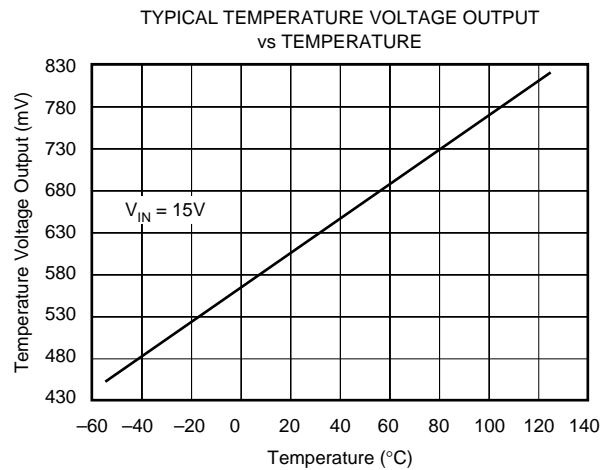
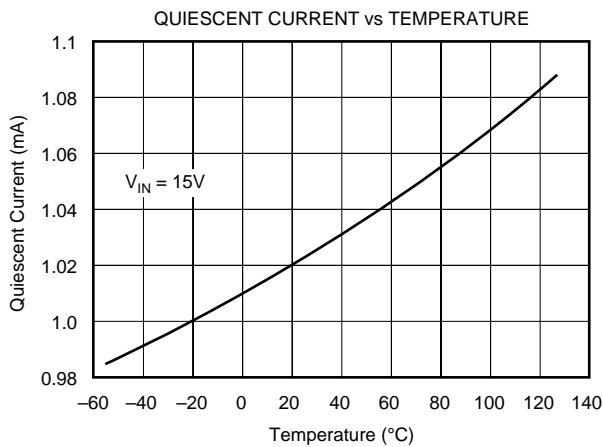
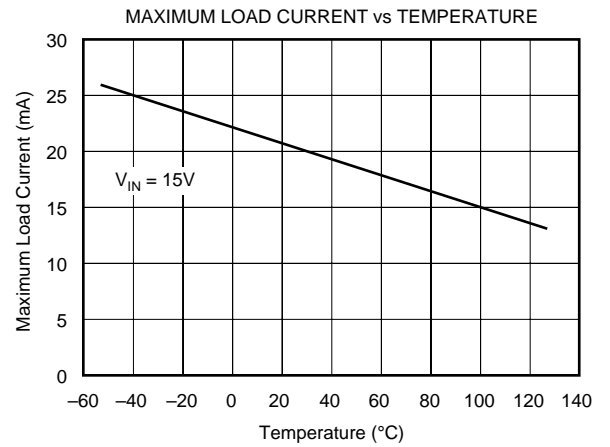
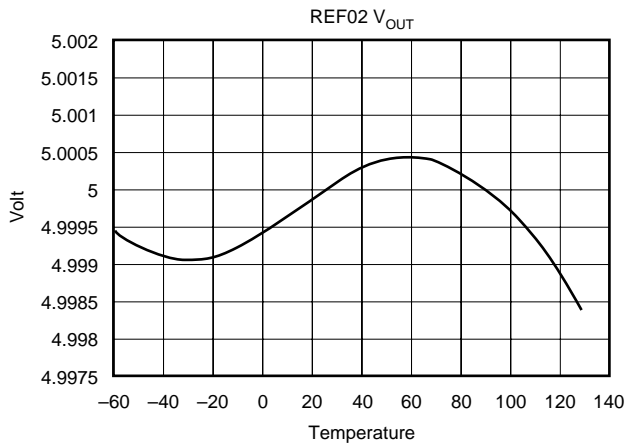
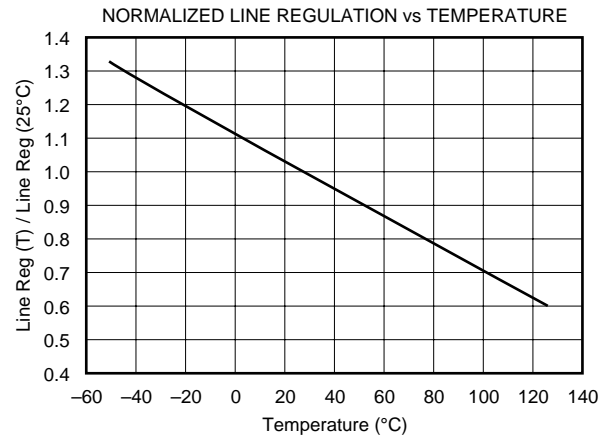
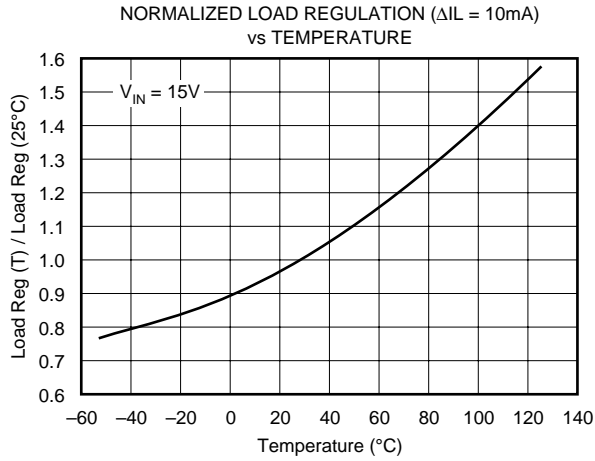

# TYPICAL PERFORMANCE CURVES (Cont.)

At  $T_A = +25^\circ\text{C}$ , unless otherwise noted.

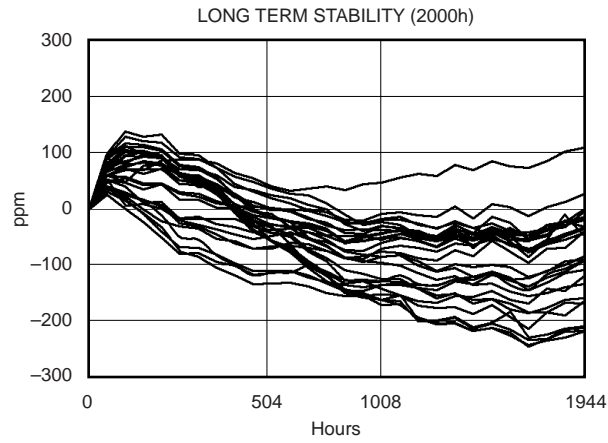
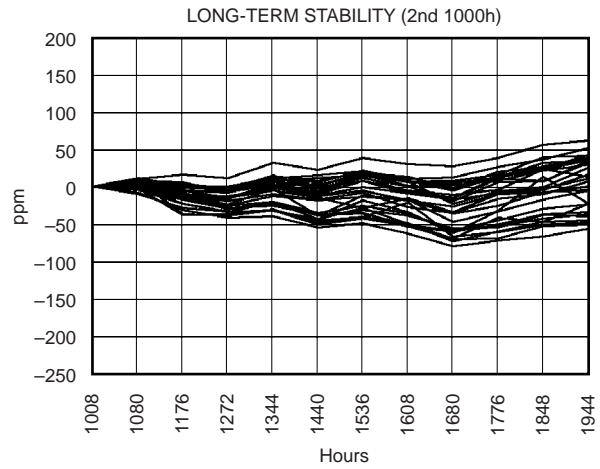
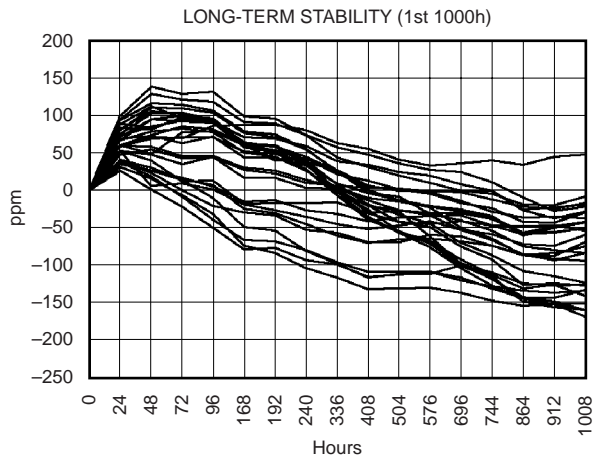

## OUTPUT ADJUSTMENT

The REF02 trim terminal can be used to adjust the voltage over a  $5V \pm 150mV$  range. This feature allows the system designer to trim system errors by setting the reference to a voltage other than 5V, including  $5.12V^{(1)}$  for binary applications (see circuit on page 1).

Adjustment of the output does not significantly affect the temperature performance of the device. The temperature coefficient change is approximately  $0.7ppm/^{\circ}C$  for 100mV of output adjustment.

NOTE: (1) 20mV LSB for 8-bit applications.

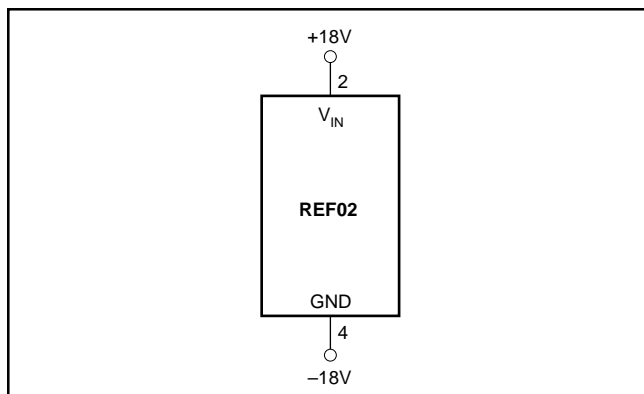

FIGURE 1. Burn-In Circuit.

## REFERENCE STACKING PROVIDES OUTSTANDING LINE REGULATION

By stacking two REF01s and one REF02, a systems designer can achieve 5V, 15V, and 25V outputs. One very important advantage of this circuit is the near-perfect line regulation at 5V and 15V outputs. This circuit can accept a 27V to 55V change to the input with less than the noise voltage as a change to the output voltage.  $R_B$ , a load bypass resistor, supplies current  $I_{SY}$  for the 15V regulator.

Any number of REF01s and REF02s can be stacked in this configuration. For example, if ten devices are stacked in this configuration, ten 5V or five 10V outputs are achieved. The line voltage may range from 100V to 130V. Care should be exercised to insure that the total load currents do not exceed the maximum usable current, which is typically 21mA.

## TYPICAL APPLICATIONS

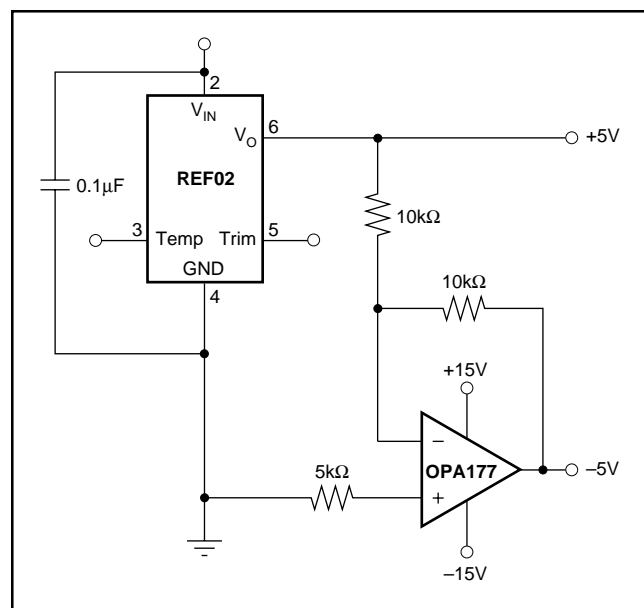

FIGURE 2.  $\pm 5V$  Precision Reference.

**PACKAGING INFORMATION**

Orderable Device	Status <sup>(1)</sup>	Package Type	Package Drawing	Pins	Package Qty	Eco Plan <sup>(2)</sup>	Lead/Ball Finish	MSL Peak Temp <sup>(3)</sup>
REF02AP	ACTIVE	PDIP	P	8	50	Green (RoHS & no Sb/Br)	CU NIPDAU	N / A for Pkg Type
REF02APG4	ACTIVE	PDIP	P	8	50	Green (RoHS & no Sb/Br)	CU NIPDAU	N / A for Pkg Type
REF02AU	ACTIVE	SOIC	D	8	75	Green (RoHS & no Sb/Br)	CU NIPDAU	Level-3-260C-168 HR
REF02AU/2K5	ACTIVE	SOIC	D	8	2500	Green (RoHS & no Sb/Br)	CU NIPDAU	Level-3-260C-168 HR
REF02AU/2K5E4	ACTIVE	SOIC	D	8	2500	Green (RoHS & no Sb/Br)	CU NIPDAU	Level-3-260C-168 HR
REF02AUE4	ACTIVE	SOIC	D	8	75	Green (RoHS & no Sb/Br)	CU NIPDAU	Level-3-260C-168 HR
REF02AUG4	ACTIVE	SOIC	D	8	75	Green (RoHS & no Sb/Br)	CU NIPDAU	Level-3-260C-168 HR
REF02BP	ACTIVE	PDIP	P	8	50	Green (RoHS & no Sb/Br)	CU NIPDAU	N / A for Pkg Type
REF02BPG4	ACTIVE	PDIP	P	8	50	Green (RoHS & no Sb/Br)	CU NIPDAU	N / A for Pkg Type
REF02BU	ACTIVE	SOIC	D	8	75	Green (RoHS & no Sb/Br)	CU NIPDAU	Level-3-260C-168 HR
REF02BU/2K5	ACTIVE	SOIC	D	8	2500	Green (RoHS & no Sb/Br)	CU NIPDAU	Level-3-260C-168 HR
REF02BU/2K5E4	ACTIVE	SOIC	D	8	2500	Green (RoHS & no Sb/Br)	CU NIPDAU	Level-3-260C-168 HR
REF02BUE4	ACTIVE	SOIC	D	8	75	Green (RoHS & no Sb/Br)	CU NIPDAU	Level-3-260C-168 HR
REF02BUG4	ACTIVE	SOIC	D	8	75	Green (RoHS & no Sb/Br)	CU NIPDAU	Level-3-260C-168 HR

<sup>(1)</sup> The marketing status values are defined as follows:

**ACTIVE:** Product device recommended for new designs.

**LIFEBUY:** TI has announced that the device will be discontinued, and a lifetime-buy period is in effect.

**NRND:** Not recommended for new designs. Device is in production to support existing customers, but TI does not recommend using this part in a new design.

**PREVIEW:** Device has been announced but is not in production. Samples may or may not be available.

**OBSOLETE:** TI has discontinued the production of the device.

<sup>(2)</sup> Eco Plan - The planned eco-friendly classification: Pb-Free (RoHS), Pb-Free (RoHS Exempt), or Green (RoHS & no Sb/Br) - please check <http://www.ti.com/productcontent> for the latest availability information and additional product content details.

**TBD:** The Pb-Free/Green conversion plan has not been defined.

**Pb-Free (RoHS):** TI's terms "Lead-Free" or "Pb-Free" mean semiconductor products that are compatible with the current RoHS requirements for all 6 substances, including the requirement that lead not exceed 0.1% by weight in homogeneous materials. Where designed to be soldered at high temperatures, TI Pb-Free products are suitable for use in specified lead-free processes.

**Pb-Free (RoHS Exempt):** This component has a RoHS exemption for either 1) lead-based flip-chip solder bumps used between the die and package, or 2) lead-based die adhesive used between the die and leadframe. The component is otherwise considered Pb-Free (RoHS compatible) as defined above.

**Green (RoHS & no Sb/Br):** TI defines "Green" to mean Pb-Free (RoHS compatible), and free of Bromine (Br) and Antimony (Sb) based flame retardants (Br or Sb do not exceed 0.1% by weight in homogeneous material)

<sup>(3)</sup> MSL, Peak Temp. -- The Moisture Sensitivity Level rating according to the JEDEC industry standard classifications, and peak solder temperature.

**Important Information and Disclaimer:**The information provided on this page represents TI's knowledge and belief as of the date that it is

provided. TI bases its knowledge and belief on information provided by third parties, and makes no representation or warranty as to the accuracy of such information. Efforts are underway to better integrate information from third parties. TI has taken and continues to take reasonable steps to provide representative and accurate information but may not have conducted destructive testing or chemical analysis on incoming materials and chemicals. TI and TI suppliers consider certain information to be proprietary, and thus CAS numbers and other limited information may not be available for release.

In no event shall TI's liability arising out of such information exceed the total purchase price of the TI part(s) at issue in this document sold by TI to Customer on an annual basis.

**TAPE AND REEL INFORMATION**



**QUADRANT ASSIGNMENTS FOR PIN 1 ORIENTATION IN TAPE**

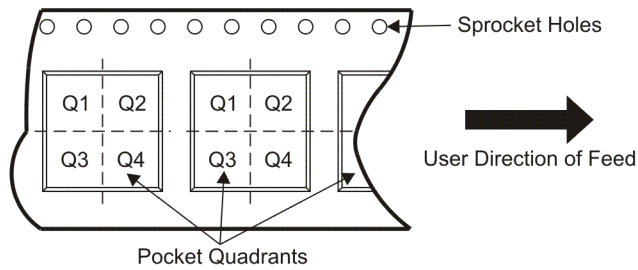

\*All dimensions are nominal

Device	Package Type	Package Drawing	Pins	SPQ	Reel Diameter (mm)	Reel Width W1 (mm)	A0 (mm)	B0 (mm)	K0 (mm)	P1 (mm)	W (mm)	Pin1 Quadrant
REF02AU/2K5	SOIC	D	8	2500	330.0	12.4	6.4	5.2	2.1	8.0	12.0	Q1
REF02BU/2K5	SOIC	D	8	2500	330.0	12.4	6.4	5.2	2.1	8.0	12.0	Q1

**TAPE AND REEL BOX DIMENSIONS**



\*All dimensions are nominal

Device	Package Type	Package Drawing	Pins	SPQ	Length (mm)	Width (mm)	Height (mm)
REF02AU/2K5	SOIC	D	8	2500	346.0	346.0	29.0
REF02BU/2K5	SOIC	D	8	2500	346.0	346.0	29.0

P (R-PDIP-T8)

PLASTIC DUAL-IN-LINE PACKAGE

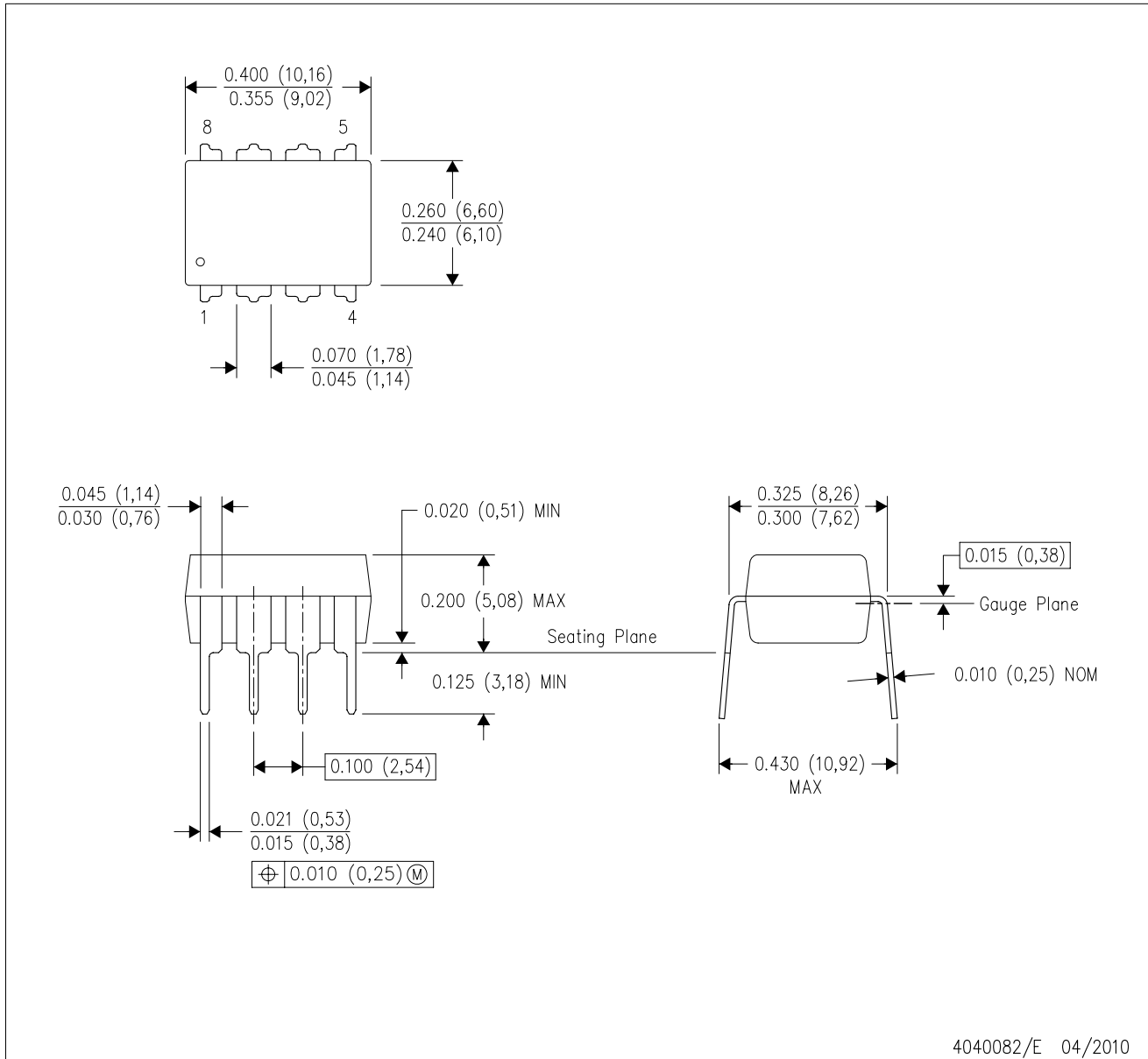

- NOTES:
- A. All linear dimensions are in inches (millimeters).
  - B. This drawing is subject to change without notice.
  - C. Falls within JEDEC MS-001 variation BA.

D (R-PDSO-G8)

PLASTIC SMALL-OUTLINE PACKAGE

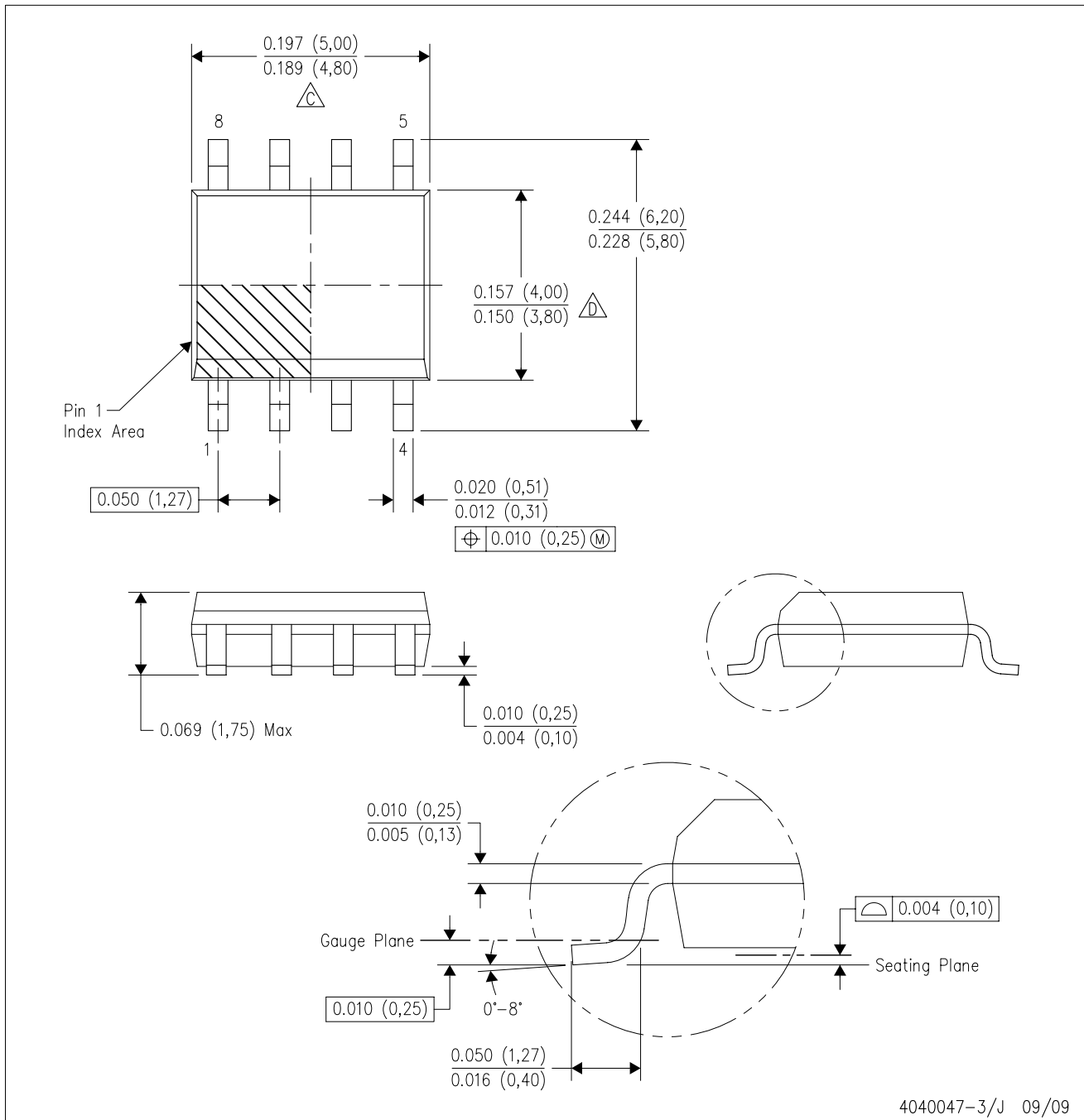

- NOTES:
- A. All linear dimensions are in inches (millimeters).
  - B. This drawing is subject to change without notice.
  - Body length does not include mold flash, protrusions, or gate burrs. Mold flash, protrusions, or gate burrs shall not exceed .006 (0,15) per end.
  - Body width does not include interlead flash. Interlead flash shall not exceed .017 (0,43) per side.
  - E. Reference JEDEC MS-012 variation AA.

## IMPORTANT NOTICE

Texas Instruments Incorporated and its subsidiaries (TI) reserve the right to make corrections, modifications, enhancements, improvements, and other changes to its products and services at any time and to discontinue any product or service without notice. Customers should obtain the latest relevant information before placing orders and should verify that such information is current and complete. All products are sold subject to TI's terms and conditions of sale supplied at the time of order acknowledgment.

TI warrants performance of its hardware products to the specifications applicable at the time of sale in accordance with TI's standard warranty. Testing and other quality control techniques are used to the extent TI deems necessary to support this warranty. Except where mandated by government requirements, testing of all parameters of each product is not necessarily performed.

TI assumes no liability for applications assistance or customer product design. Customers are responsible for their products and applications using TI components. To minimize the risks associated with customer products and applications, customers should provide adequate design and operating safeguards.

TI does not warrant or represent that any license, either express or implied, is granted under any TI patent right, copyright, mask work right, or other TI intellectual property right relating to any combination, machine, or process in which TI products or services are used. Information published by TI regarding third-party products or services does not constitute a license from TI to use such products or services or a warranty or endorsement thereof. Use of such information may require a license from a third party under the patents or other intellectual property of the third party, or a license from TI under the patents or other intellectual property of TI.

Reproduction of TI information in TI data books or data sheets is permissible only if reproduction is without alteration and is accompanied by all associated warranties, conditions, limitations, and notices. Reproduction of this information with alteration is an unfair and deceptive business practice. TI is not responsible or liable for such altered documentation. Information of third parties may be subject to additional restrictions.

Resale of TI products or services with statements different from or beyond the parameters stated by TI for that product or service voids all express and any implied warranties for the associated TI product or service and is an unfair and deceptive business practice. TI is not responsible or liable for any such statements.

TI products are not authorized for use in safety-critical applications (such as life support) where a failure of the TI product would reasonably be expected to cause severe personal injury or death, unless officers of the parties have executed an agreement specifically governing such use. Buyers represent that they have all necessary expertise in the safety and regulatory ramifications of their applications, and acknowledge and agree that they are solely responsible for all legal, regulatory and safety-related requirements concerning their products and any use of TI products in such safety-critical applications, notwithstanding any applications-related information or support that may be provided by TI. Further, Buyers must fully indemnify TI and its representatives against any damages arising out of the use of TI products in such safety-critical applications.

TI products are neither designed nor intended for use in military/aerospace applications or environments unless the TI products are specifically designated by TI as military-grade or "enhanced plastic." Only products designated by TI as military-grade meet military specifications. Buyers acknowledge and agree that any such use of TI products which TI has not designated as military-grade is solely at the Buyer's risk, and that they are solely responsible for compliance with all legal and regulatory requirements in connection with such use.

TI products are neither designed nor intended for use in automotive applications or environments unless the specific TI products are designated by TI as compliant with ISO/TS 16949 requirements. Buyers acknowledge and agree that, if they use any non-designated products in automotive applications, TI will not be responsible for any failure to meet such requirements.

Following are URLs where you can obtain information on other Texas Instruments products and application solutions:

<b>Products</b>		<b>Applications</b>	
Amplifiers	<a href="http://amplifier.ti.com">amplifier.ti.com</a>	Audio	<a href="http://www.ti.com/audio">www.ti.com/audio</a>
Data Converters	<a href="http://dataconverter.ti.com">dataconverter.ti.com</a>	Automotive	<a href="http://www.ti.com/automotive">www.ti.com/automotive</a>
DLP® Products	<a href="http://www.dlp.com">www.dlp.com</a>	Communications and Telecom	<a href="http://www.ti.com/communications">www.ti.com/communications</a>
DSP	<a href="http://dsp.ti.com">dsp.ti.com</a>	Computers and Peripherals	<a href="http://www.ti.com/computers">www.ti.com/computers</a>
Clocks and Timers	<a href="http://www.ti.com/clocks">www.ti.com/clocks</a>	Consumer Electronics	<a href="http://www.ti.com/consumer-apps">www.ti.com/consumer-apps</a>
Interface	<a href="http://interface.ti.com">interface.ti.com</a>	Energy	<a href="http://www.ti.com/energy">www.ti.com/energy</a>
Logic	<a href="http://logic.ti.com">logic.ti.com</a>	Industrial	<a href="http://www.ti.com/industrial">www.ti.com/industrial</a>
Power Mgmt	<a href="http://power.ti.com">power.ti.com</a>	Medical	<a href="http://www.ti.com/medical">www.ti.com/medical</a>
Microcontrollers	<a href="http://microcontroller.ti.com">microcontroller.ti.com</a>	Security	<a href="http://www.ti.com/security">www.ti.com/security</a>
RFID	<a href="http://www.ti-rfid.com">www.ti-rfid.com</a>	Space, Avionics & Defense	<a href="http://www.ti.com/space-avionics-defense">www.ti.com/space-avionics-defense</a>
RF/IF and ZigBee® Solutions	<a href="http://www.ti.com/lprf">www.ti.com/lprf</a>	Video and Imaging	<a href="http://www.ti.com/video">www.ti.com/video</a>
		Wireless	<a href="http://www.ti.com/wireless-apps">www.ti.com/wireless-apps</a>