

RC4136, RM4136, RV4136 QUAD GENERAL-PURPOSE OPERATIONAL AMPLIFIERS

The RM4136 and RV4136 are obsolete and are no longer supplied.

SLOS072A – MARCH 1978 – REVISED JANUARY 2002

- Continuous Short-Circuit Protection
- Wide Common-Mode and Differential Voltage Ranges
- No Frequency Compensation Required
- Low Power Consumption
- No Latch-Up
- Unity-Gain Bandwidth . . . 3 MHz Typ
- Gain and Phase Match Between Amplifiers
- Designed To Be Interchangeable With Raytheon RC4136, RM4136, and RV4136
- Low Noise . . . 8 nV $\sqrt{\text{Hz}}$ Typ at 1 kHz

description

The RC4136, RM4136, and RV4136 are quad general-purpose operational amplifiers, with each amplifier electrically similar to the $\mu\text{A}741$, except that offset null capability is not provided.

The high common-mode input voltage range and the absence of latch-up make these amplifiers ideal for voltage-follower applications. The devices are short-circuit protected and the internal frequency compensation ensures stability without external components.

The RC4136 is characterized for operation from 0°C to 70°C, the RM4136 is characterized for operation over the full military temperature range of -55°C to 125°C, and the RV4136 is characterized for operation from -40°C to 85°C.

RM4136 . . . J OR W PACKAGE
ALL OTHERS . . . D OR N PACKAGE
(TOP VIEW)

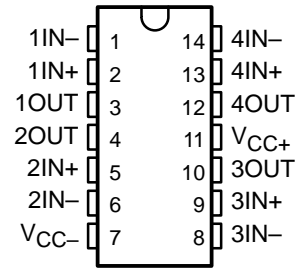

RM4136 . . . FK PACKAGE
(TOP VIEW)

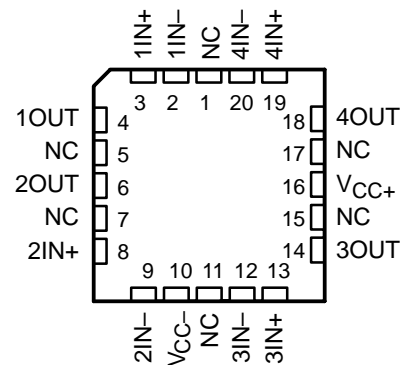

NC – No internal connection

symbol (each amplifier)

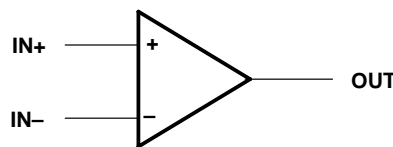

AVAILABLE OPTIONS

T _A	V _{IO} MAX AT 25°C	PACKAGE				
		SMALL OUTLINE (D)	CHIP CARRIER (FK)	CERAMIC DIP (J)	PLASTIC DIP (N)	FLAT (W)
0°C to 70°C	6 mV	RC4136D	—	—	RC4136N	—
-40°C to 85°C	6 mV	RV4136D	—	—	RV4136N	—
-55°C to 125°C	4 mV	—	RM4136FK	RM4136J	—	RM4136W

The D packages are available taped and reeled. Add the suffix R to the device type (e.g., RC4136DR).



Please be aware that an important notice concerning availability, standard warranty, and use in critical applications of Texas Instruments semiconductor products and disclaimers thereto appears at the end of this data sheet.

PRODUCTION DATA information is current as of publication date. Products conform to specifications per the terms of Texas Instruments standard warranty. Production processing does not necessarily include testing of all parameters.

 **TEXAS
INSTRUMENTS**

POST OFFICE BOX 655303 • DALLAS, TEXAS 75265

Copyright © 2002, Texas Instruments Incorporated
On products compliant to MIL-PRF-38535, all parameters are tested unless otherwise noted. On all other products, production processing does not necessarily include testing of all parameters.

RC4136, RM4136, RV4136 QUAD GENERAL-PURPOSE OPERATIONAL AMPLIFIERS

The RM4136 and RV4136 are
obsolete and are no longer supplied.

SLOS072A – MARCH 1978 – REVISED JANUARY 2002

schematic (each amplifier)

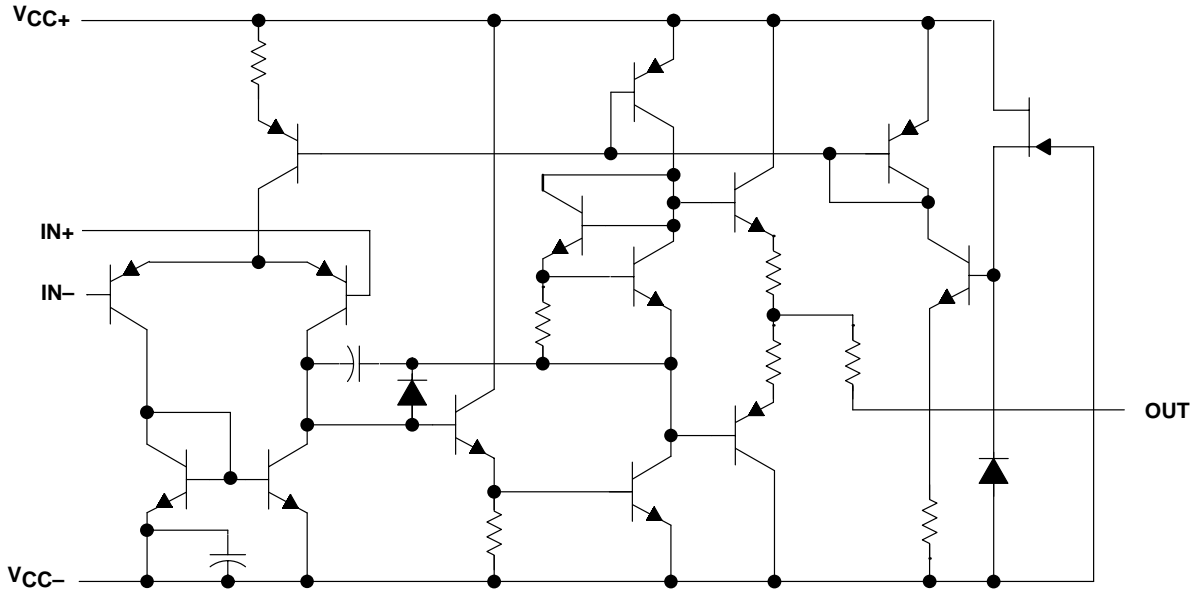

absolute maximum ratings over operating free-air temperature range (unless otherwise noted)†

Supply voltage (see Note 1): V_{CC+} , RC4136 and RV4136	18 V
V_{CC+} , RM4136	22 V
V_{CC-} , RC4136 and RV4136	-18 V
V_{CC-} , RM4136	-22 V
Differential input voltage, V_{ID} (see Note 2)	± 30 V
Input voltage, V_I (any input) (see Notes 1 and 3)	± 15 V
Duration of output short circuit to ground, one amplifier at a time (see Note 4)	Unlimited
Continuous total dissipation	See Dissipation Rating Table
Package thermal impedance, θ_{JA} (see Note 5): D package	86°C/W
N package	80°C/W
Case temperature for 60 seconds: FK package	260°C
Lead temperature 1,6 mm (1/16 inch) from case for 10 seconds: D or N package	260°C
Lead temperature 1,6 mm (1/16 inch) from case for 60 seconds: J or W package	300°C
Storage temperature range, T_{stg}	-65°C to 150°C

† Stresses beyond those listed under "absolute maximum ratings" may cause permanent damage to the device. These are stress ratings only, and functional operation of the device at these or any other conditions beyond those indicated under "recommended operating conditions" is not implied. Exposure to absolute-maximum-rated conditions for extended periods may affect device reliability.

- NOTES: 1. All voltage values, unless otherwise noted, are with respect to the midpoint between V_{CC+} and V_{CC-} .
 2. Differential voltages are at IN+ with respect to IN-.
 3. The magnitude of the input voltage must never exceed the magnitude of the supply voltage or 15 V, whichever is less.
 4. Temperature and/or supply voltages must be limited to ensure that the dissipation rating is not exceeded.
 5. The package thermal impedance is calculated in accordance with JESD 51-7.

DISSIPATION RATING TABLE

PACKAGE	$T_A \leq 25^\circ\text{C}$ POWER RATING	DERATING FACTOR	DERATE ABOVE T_A	$T_A = 70^\circ\text{C}$ POWER RATING	$T_A = 85^\circ\text{C}$ POWER RATING	$T_A = 125^\circ\text{C}$ POWER RATING
FK	800 mW	11.0 mW/°C	77°C	800 mW	715 mW	275 mW
J	800 mW	11.0 mW/°C	77°C	800 mW	715 mW	275 mW
W	800 mW	8.0 mW/°C	50°C	640 mW	520 mW	200 mW



POST OFFICE BOX 655303 • DALLAS, TEXAS 75265

RC4136, RM4136, RV4136 QUAD GENERAL-PURPOSE OPERATIONAL AMPLIFIERS

The RM4136 and RV4136 are
obsolete and are no longer supplied.

SLOS072A – MARCH 1978 – REVISED JANUARY 2002

recommended operating conditions

		MIN	MAX	UNIT
V_{CC+}	Supply voltage	5	15	V
V_{CC-}	Supply voltage	-5	-15	V

electrical characteristics at specified free-air temperature, $V_{CC+} = 15\text{ V}$, $V_{CC-} = -15\text{ V}$

PARAMETER	TEST CONDITIONS†	RC4136			RM4136			RV4136			UNIT
		MIN	TYP	MAX	MIN	TYP	MAX	MIN	TYP	MAX	
V_{IL} Input offset voltage	$V_O = 0$	25°C	0.5	6	0.5	4	0.5	6	mV		
		Full range		7.5		6		7.5			
I_{IO} Input offset current	$V_O = 0$	25°C	5	200	5	150	5	200	nA		
		Full range		300		500		500			
I_{IB} Input bias current	$V_O = 0$	25°C	140	500	140	400	140	500	nA		
		Full range		800		1500		1500			
V_i Input voltage range		25°C	±12	±14	±12	±14	±12	±14	V		
V_{OM} Maximum peak output voltage swing	$R_L = 10\text{ k}\Omega$	25°C	±12	±14	±12	±14	±12	±14	V		
	$R_L = 2\text{ k}\Omega$	25°C	±10	±13	±10	±13	±10	±13			
	$R_L \geq 2\text{ k}\Omega$	Full range	±10		±10		±10				
A_{VD} Large-signal differential voltage amplification	$V_O = \pm 10\text{ V}$, $R_L \geq 2\text{ k}\Omega$	25°C	20	300	50	350	20	300	V/mV		
		Full range	15		25		15				
B_1 Unity-gain bandwidth		25°C		3		3.5		3	MHz		
r_i Input resistance		25°C	0.3*	5	0.3*	5	0.3*	5	MΩ		
CMRR Common-mode rejection ratio	$V_O = 0$, $R_S = 50\ \Omega$	25°C	70	90	70	90	70	90	dB		
k_{SVS} Supply-voltage sensitivity ($\Delta V_{IO}/\Delta V_{CC}$)	$V_{CC} = \pm 9\text{ V to } \pm 15\text{ V}$, $V_O = 0$	25°C		30	150		30	150	μV/V		
V_n Equivalent input noise voltage (closed loop)	$A_{VD} = 100$, BW = 1 Hz, f = 1 kHz, $R_S = 100\ \Omega$	25°C		8		8		8	nV $\sqrt{\text{Hz}}$		
I_{CC} Supply current (all four amplifiers)	$V_O = 0$, No load	25°C		5	11.3		5	11.3	mA		
		MIN T_A		6	13.7		6	13.7			
		MAX T_A		4.5	10		4.5	10			
P_D Total power dissipation (all four amplifiers)	$V_O = 0$, No load	25°C		150	340		150	340	mW		
		MIN T_A		180	400		180	400			
		MAX T_A		135	300		135	300			
Crosstalk attenuation (V_{O1}/V_{O2})	$A_{VD} = 100$, f = 10 kHz, $R_S = 1\text{ k}\Omega$	25°C		105		105		105	dB		

* This parameter is not production tested.

† All characteristics are measured under open-loop conditions with zero common-mode input voltage, unless otherwise specified. Full range is 0°C to 70°C for RC4136, -55°C to 125°C for RM4136, and -40°C to 85°C for RV4136. Minimum T_A is 0°C for RC4136, -55°C for RM4136, and -40°C for RV4136. Maximum T_A is 70°C for RC4136, 125°C for RM4136, and 85°C for RV4136.



RC4136, RM4136, RV4136 QUAD GENERAL-PURPOSE OPERATIONAL AMPLIFIERS

The RM4136 and RV4136 are
obsolete and are no longer supplied.

SLOS072A – MARCH 1978 – REVISED JANUARY 2002

operating characteristics, $V_{CC+} = 15\text{ V}$, $V_{CC-} = -15\text{ V}$, $T_A = 25^\circ\text{C}$

PARAMETER		TEST CONDITIONS	TYP	UNIT
t_r	Rise time	$V_I = 20\text{ mV}$, $C_L = 100\text{ pF}$, $R_L = 2\text{ k}\Omega$	0.13	μs
	Overshoot factor	$V_I = 20\text{ mV}$, $C_L = 100\text{ pF}$, $R_L = 2\text{ k}\Omega$	5	%
SR	Slew rate at unity gain	$V_I = 10\text{ V}$, $C_L = 100\text{ pF}$, $R_L = 2\text{ k}\Omega$	1.7	$\text{V}/\mu\text{s}$



POST OFFICE BOX 655303 • DALLAS, TEXAS 75265

PACKAGING INFORMATION

Orderable Device	Status ⁽¹⁾	Package Type	Package Drawing	Pins	Package Qty	Eco Plan ⁽²⁾	Lead/ Ball Finish	MSL Peak Temp ⁽³⁾	Samples (Requires Login)
RC4136D	OBSOLETE	SOIC	D	14		TBD	Call TI	Call TI	Samples Not Available
RC4136DR	OBSOLETE	SOIC	D	14		TBD	Call TI	Call TI	Samples Not Available
RC4136N	ACTIVE	PDIP	N	14	25	Pb-Free (RoHS)	CU NIPDAU	N / A for Pkg Type	Contact TI Distributor or Sales Office
RC4136NE4	ACTIVE	PDIP	N	14	25	Pb-Free (RoHS)	CU NIPDAU	N / A for Pkg Type	Contact TI Distributor or Sales Office

⁽¹⁾ The marketing status values are defined as follows:

ACTIVE: Product device recommended for new designs.

LIFEBUY: TI has announced that the device will be discontinued, and a lifetime-buy period is in effect.

NRND: Not recommended for new designs. Device is in production to support existing customers, but TI does not recommend using this part in a new design.

PREVIEW: Device has been announced but is not in production. Samples may or may not be available.

OBSOLETE: TI has discontinued the production of the device.

⁽²⁾ Eco Plan - The planned eco-friendly classification: Pb-Free (RoHS), Pb-Free (RoHS Exempt), or Green (RoHS & no Sb/Br) - please check <http://www.ti.com/productcontent> for the latest availability information and additional product content details.

TBD: The Pb-Free/Green conversion plan has not been defined.

Pb-Free (RoHS): TI's terms "Lead-Free" or "Pb-Free" mean semiconductor products that are compatible with the current RoHS requirements for all 6 substances, including the requirement that lead not exceed 0.1% by weight in homogeneous materials. Where designed to be soldered at high temperatures, TI Pb-Free products are suitable for use in specified lead-free processes.

Pb-Free (RoHS Exempt): This component has a RoHS exemption for either 1) lead-based flip-chip solder bumps used between the die and package, or 2) lead-based die adhesive used between the die and leadframe. The component is otherwise considered Pb-Free (RoHS compatible) as defined above.

Green (RoHS & no Sb/Br): TI defines "Green" to mean Pb-Free (RoHS compatible), and free of Bromine (Br) and Antimony (Sb) based flame retardants (Br or Sb do not exceed 0.1% by weight in homogeneous material)

⁽³⁾ MSL, Peak Temp. -- The Moisture Sensitivity Level rating according to the JEDEC industry standard classifications, and peak solder temperature.

Important Information and Disclaimer: The information provided on this page represents TI's knowledge and belief as of the date that it is provided. TI bases its knowledge and belief on information provided by third parties, and makes no representation or warranty as to the accuracy of such information. Efforts are underway to better integrate information from third parties. TI has taken and continues to take reasonable steps to provide representative and accurate information but may not have conducted destructive testing or chemical analysis on incoming materials and chemicals. TI and TI suppliers consider certain information to be proprietary, and thus CAS numbers and other limited information may not be available for release.

In no event shall TI's liability arising out of such information exceed the total purchase price of the TI part(s) at issue in this document sold by TI to Customer on an annual basis.

N (R-PDIP-T**)

PLASTIC DUAL-IN-LINE PACKAGE

16 PINS SHOWN

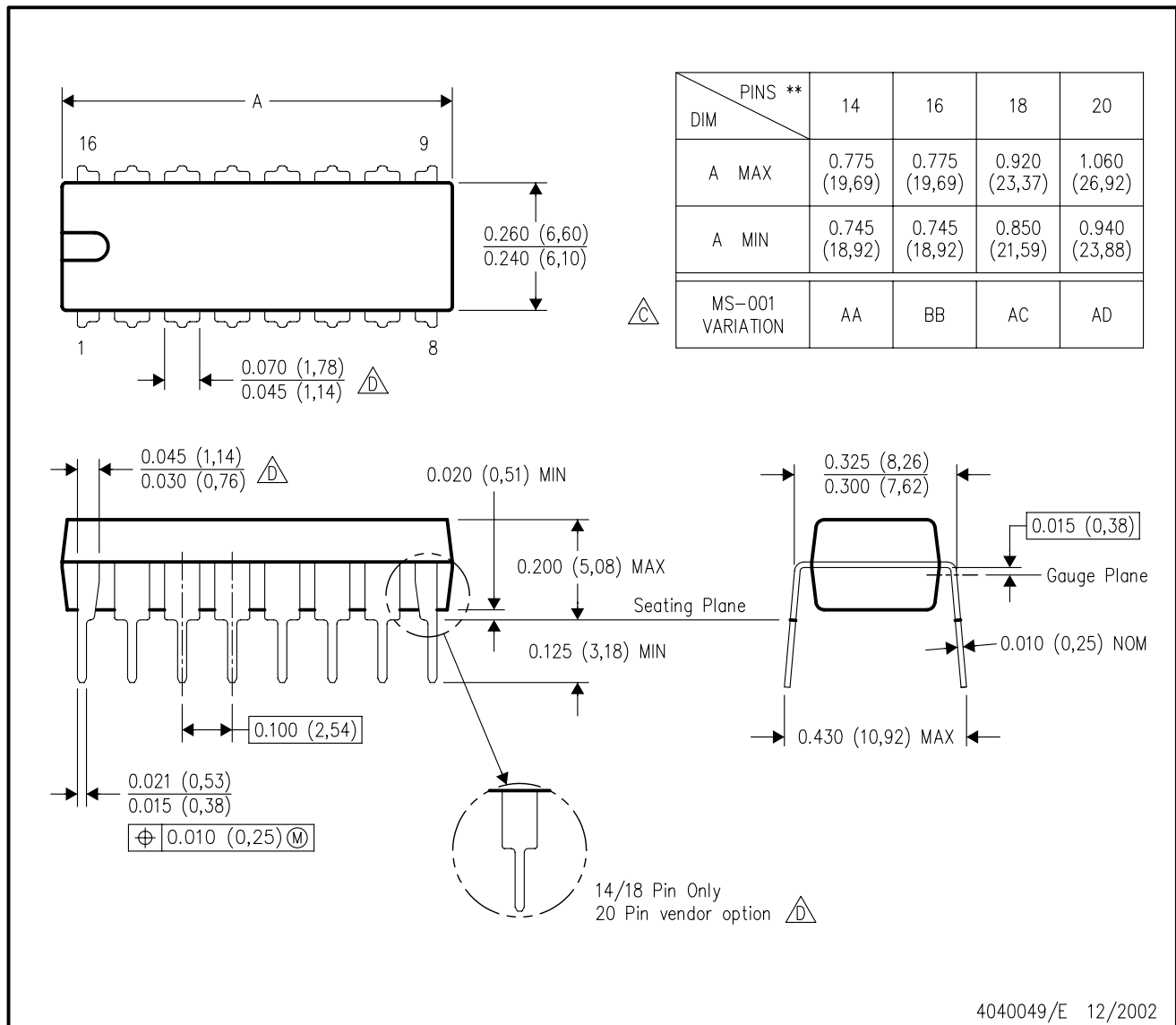



- NOTES:
- A. All linear dimensions are in inches (millimeters).
 - B. This drawing is subject to change without notice.
 - $\triangle C$ Falls within JEDEC MS-001, except 18 and 20 pin minimum body length (Dim A).
 - $\triangle D$ The 20 pin end lead shoulder width is a vendor option, either half or full width.

D (R-PDSO-G14)

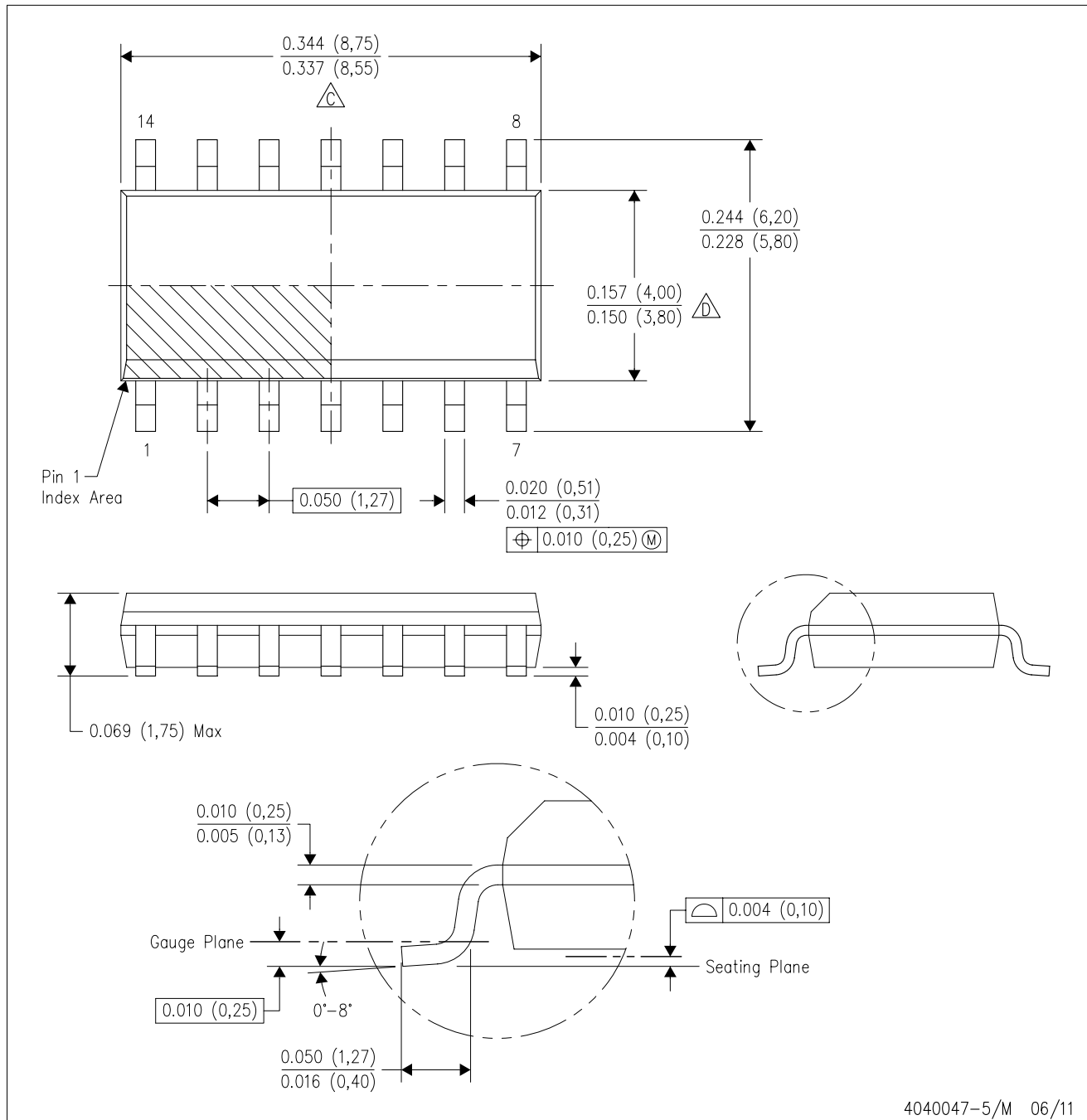
PLASTIC SMALL OUTLINE



- NOTES:
- A. All linear dimensions are in inches (millimeters).
 - B. This drawing is subject to change without notice.
 -  Body length does not include mold flash, protrusions, or gate burrs. Mold flash, protrusions, or gate burrs shall not exceed 0.006 (0,15) each side.
 -  Body width does not include interlead flash. Interlead flash shall not exceed 0.017 (0,43) each side.
 - E. Reference JEDEC MS-012 variation AB.

IMPORTANT NOTICE

Texas Instruments Incorporated and its subsidiaries (TI) reserve the right to make corrections, modifications, enhancements, improvements, and other changes to its products and services at any time and to discontinue any product or service without notice. Customers should obtain the latest relevant information before placing orders and should verify that such information is current and complete. All products are sold subject to TI's terms and conditions of sale supplied at the time of order acknowledgment.

TI warrants performance of its hardware products to the specifications applicable at the time of sale in accordance with TI's standard warranty. Testing and other quality control techniques are used to the extent TI deems necessary to support this warranty. Except where mandated by government requirements, testing of all parameters of each product is not necessarily performed.

TI assumes no liability for applications assistance or customer product design. Customers are responsible for their products and applications using TI components. To minimize the risks associated with customer products and applications, customers should provide adequate design and operating safeguards.

TI does not warrant or represent that any license, either express or implied, is granted under any TI patent right, copyright, mask work right, or other TI intellectual property right relating to any combination, machine, or process in which TI products or services are used. Information published by TI regarding third-party products or services does not constitute a license from TI to use such products or services or a warranty or endorsement thereof. Use of such information may require a license from a third party under the patents or other intellectual property of the third party, or a license from TI under the patents or other intellectual property of TI.

Reproduction of TI information in TI data books or data sheets is permissible only if reproduction is without alteration and is accompanied by all associated warranties, conditions, limitations, and notices. Reproduction of this information with alteration is an unfair and deceptive business practice. TI is not responsible or liable for such altered documentation. Information of third parties may be subject to additional restrictions.

Resale of TI products or services with statements different from or beyond the parameters stated by TI for that product or service voids all express and any implied warranties for the associated TI product or service and is an unfair and deceptive business practice. TI is not responsible or liable for any such statements.

TI products are not authorized for use in safety-critical applications (such as life support) where a failure of the TI product would reasonably be expected to cause severe personal injury or death, unless officers of the parties have executed an agreement specifically governing such use. Buyers represent that they have all necessary expertise in the safety and regulatory ramifications of their applications, and acknowledge and agree that they are solely responsible for all legal, regulatory and safety-related requirements concerning their products and any use of TI products in such safety-critical applications, notwithstanding any applications-related information or support that may be provided by TI. Further, Buyers must fully indemnify TI and its representatives against any damages arising out of the use of TI products in such safety-critical applications.

TI products are neither designed nor intended for use in military/aerospace applications or environments unless the TI products are specifically designated by TI as military-grade or "enhanced plastic." Only products designated by TI as military-grade meet military specifications. Buyers acknowledge and agree that any such use of TI products which TI has not designated as military-grade is solely at the Buyer's risk, and that they are solely responsible for compliance with all legal and regulatory requirements in connection with such use.

TI products are neither designed nor intended for use in automotive applications or environments unless the specific TI products are designated by TI as compliant with ISO/TS 16949 requirements. Buyers acknowledge and agree that, if they use any non-designated products in automotive applications, TI will not be responsible for any failure to meet such requirements.

Following are URLs where you can obtain information on other Texas Instruments products and application solutions:

Products

Audio	www.ti.com/audio
Amplifiers	amplifier.ti.com
Data Converters	dataconverter.ti.com
DLP® Products	www.dlp.com
DSP	dsp.ti.com
Clocks and Timers	www.ti.com/clocks
Interface	interface.ti.com
Logic	logic.ti.com
Power Mgmt	power.ti.com
Microcontrollers	microcontroller.ti.com
RFID	www.ti-rfid.com
RF/IF and ZigBee® Solutions	www.ti.com/lprf

Applications

Communications and Telecom	www.ti.com/communications
Computers and Peripherals	www.ti.com/computers
Consumer Electronics	www.ti.com/consumer-apps
Energy and Lighting	www.ti.com/energy
Industrial	www.ti.com/industrial
Medical	www.ti.com/medical
Security	www.ti.com/security
Space, Avionics and Defense	www.ti.com/space-avionics-defense
Transportation and Automotive	www.ti.com/automotive
Video and Imaging	www.ti.com/video
Wireless	www.ti.com/wireless-apps

TI E2E Community Home Page

e2e.ti.com

Mailing Address: Texas Instruments, Post Office Box 655303, Dallas, Texas 75265
Copyright © 2011, Texas Instruments Incorporated