

Distributed by:

**JAMECO**<sup>®</sup>  
ELECTRONICS

**www.Jameco.com ♦ 1-800-831-4242**

The content and copyrights of the attached  
material are the property of its owner.

Jameco Part Number 907884

## 12-A, 12-V INPUT NON-ISOLATED WIDE-OUTPUT ADJUST POWER MODULE



### FEATURES

- Up to 12-A Output Current
- 12-V Input Voltage
- Wide-Output Voltage Adjust (1.2 V to 5.5 V)/(0.8 V to 1.8 V)
- Efficiencies up to 94%
- 200 W/in<sup>3</sup> Power Density
- On/Off Inhibit
- Output Voltage Sense
- Prebias Startup
- Undervoltage Lockout
- Auto-Track™ Sequencing
- Margin Up/Down Controls
- Output Overcurrent Protection (Nonlatching, Auto-Reset)
- Operating Temperature: –40°C to 85°C
- Safety Agency Approvals: UL /cUL 60950, EN60950 VDE
- Point of Load Alliance (POLA™) Compatible

### APPLICATIONS

- Complex Multivoltage, Multiprocessor Systems



Nominal Size = 1.37 in x 0.62 in  
(34,8 mm x 15,75 mm)

### DESCRIPTION

The PTH12010 series of non-isolated power modules that are small in size but big on performance and flexibility. The high output current, compact footprint, and industry-leading features offers system designers a versatile module for powering complex multi-processor digital systems.

The series employs double-sided surface mount construction and provides high-performance step-down power conversion for up to 12 A of output current. The output voltage of the W-suffix parts can be set to any value over the range, 1.2 V to 5.5 V. The L-suffix devices have an adjustment range of 0.8 V to 1.8 V. The output voltage is set using a single external resistor.

This series includes Auto-Track™ sequencing. Auto-Track simplifies the task of supply voltage sequencing in a power system by enabling modules to track each other, or any external voltage, during power up and power down.

Other operating features include an on/off inhibit, output voltage adjust (trim), margin up/down controls, and the ability to start up into an existing output voltage or prebias. For improved load regulation, an output voltage sense is also provided. A nonlatching overcurrent trip serves as load fault protection.

Target applications include complex multivoltage, multiprocessor systems that incorporate the industry's high-speed TMS320™ DSP family, microprocessors, and bus drivers.



Please be aware that an important notice concerning availability, standard warranty, and use in critical applications of Texas Instruments semiconductor products and disclaimers thereto appears at the end of this data sheet.

Auto-Track, TMS320, POLA are trademarks of Texas Instruments.



These devices have limited built-in ESD protection. The leads should be shorted together or the device placed in conductive foam during storage or handling to prevent electrostatic damage to the MOS gates.

**STANDARD APPLICATION**

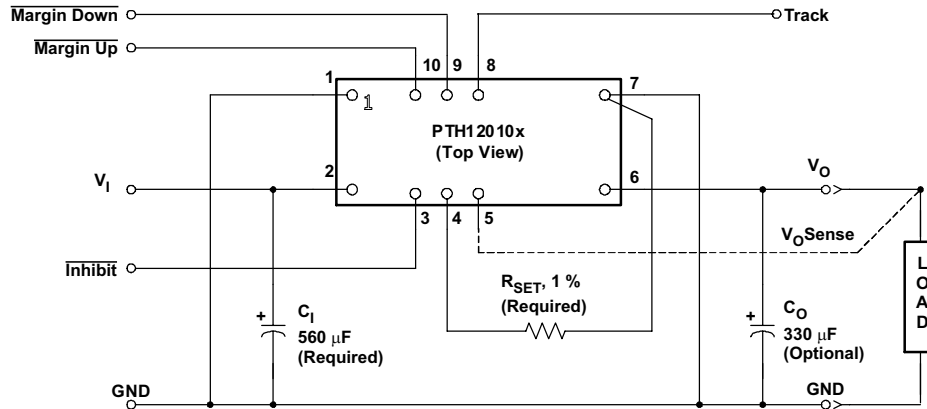

AR<sub>SET</sub> = Required to set the output voltage to a value higher than the lowest value (see the electrical characteristics table for values).

**ORDERING INFORMATION**

For the most current package and ordering information, see the Package Option Addendum at the end of this datasheet, or see the TI website at [www.ti.com](http://www.ti.com).

**ABSOLUTE MAXIMUM RATINGS**

Voltages are with respect to GND

			MIN	TYP	MAX	UNIT
V <sub>track</sub>	Track Input Voltage		-0.3		V <sub>I</sub> + 0.3	V
T <sub>A</sub>	Operating Temperature Range	Over V <sub>in</sub> Range	-40 <sup>(1)</sup>		85	°C
T <sub>wave</sub>	Wave solder temperature	Surface temperature of module body or pins <b>(5 seconds)</b>			260 <sup>(2)</sup>	°C
T <sub>reflow</sub>	Solder reflow temperature	Surface temperature of module body or pins			235 <sup>(2)</sup>	
					260 <sup>(2)</sup>	
T <sub>stg</sub>	Storage Temperature		-40		125	°C
	Mechanical Shock	Per Mil-STD-883D, Method 2002.3, 1 msec, 1/2 Sine, mounted		500		G
	Mechanical Vibration	Mil-STD-883D, Method 2007.2 20-2000 Hz		20		G
	Weight			5		grams
	Flammability	Meets UL 94V-O				

- (1) For operation below 0°C the external capacitors must have stable characteristics. Use either a low-ESR tantalum, Os-Con, or ceramic capacitor.
- (2) During soldering of package version, do not elevate peak temperature of the module, pins or internal components above the stated maximum.

**ELECTRICAL CHARACTERISTICS**

$T_A = 25^\circ\text{C}$ ,  $V_i = 12\text{ V}$ ,  $V_o = 3.3\text{ V}$ ,  $C_i = 560\ \mu\text{F}$ ,  $C_o = 0\ \mu\text{F}$ , and  $I_o = I_o\ \text{max}$  (Unless otherwise stated)

CHARACTERISTICS		CONDITIONS		PTH12010W			
				MIN	TYP	MAX	UNIT
$I_o$	Output current	$1.2\text{ V} \leq V_o \leq 5.5\text{ V}$	60 °C, 200 LFM airflow	0	12 <sup>(3)</sup>	A	
			25 °C, natural convection	0	12 <sup>(1)</sup>		
$V_i$	Input voltage range	Over $I_o$ range		10.8	13.2	V	
$V_o\ \text{tol}$	Set-point voltage tolerance				$\pm 2$ <sup>(4)</sup>	% $V_o$	
$\Delta\text{Reg}_{\text{temp}}$	Temperature variation	$-40\text{ }^\circ\text{C} < T_A < 85\text{ }^\circ\text{C}$			$\pm 0.5$	% $V_o$	
$\Delta\text{Reg}_{\text{line}}$	Line regulation	Over $V_i$ range			$\pm 10$	mV	
$\Delta\text{Reg}_{\text{load}}$	Load regulation	Over $I_o$ range			$\pm 12$	mV	
$\Delta\text{Reg}_{\text{tot}}$	Total output variation	Includes set-point, line, load, $-40\text{ }^\circ\text{C} \leq T_A \leq 85\text{ }^\circ\text{C}$			$\pm 3$ <sup>(2)</sup>	% $V_o$	
$\Delta V_{\text{adj}}$	Output voltage adjust range	Over $V_i$ range		1.2	5.5	V	
$\eta$	Efficiency	$I_o = 8\text{ A}$	$R_{\text{SET}} = 280\ \Omega$ , $V_o = 5\text{ V}$		94	%	
			$R_{\text{SET}} = 2.0\ \text{k}\Omega$ , $V_o = 3.3\text{ V}$		93		
			$R_{\text{SET}} = 4.32\ \text{k}\Omega$ , $V_o = 2.5\text{ V}$		91		
			$R_{\text{SET}} = 11.5\ \text{k}\Omega$ , $V_o = 1.8\text{ V}$		89		
			$R_{\text{SET}} = 24.3\ \text{k}\Omega$ , $V_o = 1.5\text{ V}$		88		
			$R_{\text{SET}} = \text{OPEN}$ , $V_o = 1.2\text{ V}$		86		
$V_r$	$V_o$ ripple (peak-to-peak)	20-MHz bandwidth	$V_o \leq 2.5\text{ V}$		25	mVpp	
			$V_o \geq 2.5\text{ V}$		1	% $V_o$	
$I_o\ \text{trip}$	Overcurrent threshold	Reset, followed by auto-recovery			20	A	
$t_{\text{tr}}$	Transient response	1 A/ $\mu\text{s}$ load step, 50 to 100 % $I_o\ \text{max}$ , $C_o = 330\ \mu\text{F}$					
			Recovery Time		70	$\mu\text{Sec}$	
		$\Delta V_{\text{tr}}$	$V_o$ over/undershoot		100	mV	
$V_o\ \text{adj}$	Margin up/down adjust				$\pm 5$	%	
$I_{\text{IL}}\ \text{margin}$	Margin input current (pins 9 /10)	Pin to GND			$-8$ <sup>(5)</sup>	$\mu\text{A}$	
$I_{\text{IL}}\ \text{track}$	Track input current (pin 8)	Pin to GND			$-0.13$ <sup>(6)</sup>	mA	
$dV_{\text{track}}/dt$	Track slew rate capability	$C_o \leq C_o(\text{max})$			1	V/ms	
UVLO	Undervoltage lockout	$V_i$ increasing			9.5	V	
		$V_i$ decreasing		8.8	9		
$V_{\text{IH}}$	Inhibit control (pin3)	Referenced to GND				V	
$V_{\text{IL}}$	Input high voltage			$V_i - 0.5$	Open <sup>(4)</sup>		
$I_{\text{IL}}\ \text{inhibit}$	Input low voltage			$-0.2$	0.5		
$I_{\text{IL}}\ \text{inh}$	Input low current	Pin to GND			0.24	mA	
$I_{\text{in}}\ \text{inh}$	Input standby current	Inhibit (pin 3) to GND, Track (pin 8) open			10	mA	
$f_s$	Switching frequency	Over $V_i$ and $I_o$ ranges		300	350	400	kHz
$C_i$	External input capacitance			560 <sup>(7)</sup>			$\mu\text{F}$

(3) See SOA curves or consult factory for appropriate derating.

(4) The set-point voltage tolerance is affected by the tolerance and stability of  $R_{\text{SET}}$ . The stated limit is unconditionally met if  $R_{\text{SET}}$  has a tolerance of 1%, with 100 ppm/ $^\circ\text{C}$  (or better) temperature stability.

(5) A small, low-leakage (<100 nA) MOSFET is recommended to control this pin. The open-circuit voltage is less than 1  $V_{\text{dc}}$ .

(6) This control pin has an internal pull-up to the input voltage  $V_i$  (7.5 V for pin 8). If it is left open-circuit the module operates when input power is applied. A small, low-leakage (<100 nA) MOSFET or open-drain/collector voltage supervisor IC is recommended for control. Do not place an external pull-up on this pin. For further information, see the related application section.

(7) A 560  $\mu\text{F}$  electrolytic input capacitor is required for proper operation. The capacitor must be rated for a minimum of 800 mA rms of ripple current.

**ELECTRICAL CHARACTERISTICS (continued)**

$T_A = 25^\circ\text{C}$ ,  $V_i = 12\text{ V}$ ,  $V_o = 3.3\text{ V}$ ,  $C_i = 560\ \mu\text{F}$ ,  $C_o = 0\ \mu\text{F}$ , and  $I_o = I_o\ \text{max}$  (Unless otherwise stated)

CHARACTERISTICS		CONDITIONS		PTH12010W			UNIT
				MIN	TYP	MAX	
$C_o$	External output capacitance	Capacitance value	nonceramic	0 <sup>(8)</sup>	330 <sup>(9)</sup>	6,600 <sup>(10)</sup>	$\mu\text{F}$
			ceramic	0		300	
		Equivalent series resistance (nonceramic)	4 <sup>(11)</sup>			$\text{m}\Omega$	
MTBF	Reliability	Per Bellcore TR-332		6.4			$10^6\ \text{Hr}$
		50% stress, $T_a = 40^\circ\text{C}$ , ground benign					

- (8) When operating at an output voltage  $\geq 3.3\text{ V}$ , 47- $\mu\text{F}$  of external output capacitance is required for proper operation.
- (9) An external output capacitor is not required for basic operation. Adding 330  $\mu\text{F}$  of distributed capacitance at the load improves the transient response.
- (10) This is the calculated maximum. The minimum ESR limitation often results in a lower value. When controlling the Track pin using a voltage supervisor,  $C_o(\text{max})$  is reduced to 3300  $\mu\text{F}$ . See the application notes for further guidance.
- (11) This is the typical ESR for all the electrolytic (nonceramic) output capacitance. Use 7  $\text{m}\Omega$  as the minimum when using max-ESR values to calculate.

**ELECTRICAL CHARACTERISTICS**

$T_A = 25^\circ\text{C}$ ,  $V_i = 12\text{ V}$ ,  $V_o = 1.8\text{ V}$ ,  $C_i = 560\ \mu\text{F}$ ,  $C_o = 0\ \mu\text{F}$ , and  $I_o = I_o\ \text{max}$  (Unless otherwise stated)

CHARACTERISTICS		CONDITIONS		PTH12010L			UNIT
				MIN	TYP	MAX	
$I_o$	Output current	$0.8\text{ V} \leq V_o \leq 1.8\text{ V}$	60 $^\circ\text{C}$ , 200 LFM airflow	0	-	12 <sup>(12)</sup>	A
			25 $^\circ\text{C}$ , natural convection	0		12 <sup>(1)</sup>	
$V_i$	Input voltage range	Over $I_o$ range		10.8		13.2	V
$V_o\ \text{tol}$	Set-point voltage tolerance					$\pm 2$ <sup>(13)</sup>	$\%V_o$
$\Delta\text{Reg}_{\text{temp}}$	Temperature variation	$-40^\circ\text{C} < T_A < 85^\circ\text{C}$			$\pm 0.5$		$\%V_o$
$\Delta\text{Reg}_{\text{line}}$	Line regulation	Over $V_i$ range			$\pm 10$		mV
$\Delta\text{Reg}_{\text{load}}$	Load regulation	Over $I_o$ range			$\pm 12$		mV
$\Delta\text{Reg}_{\text{tot}}$	Total output variation	Includes set-point, line, load, $-40^\circ\text{C} \leq T_A \leq 85^\circ\text{C}$				$\pm 3$ <sup>(2)</sup>	$\%V_o$
$\Delta V_{\text{adj}}$	Output voltage adjust range	Over $V_i$ range		0.8		1.8	V
$\eta$	Efficiency	$I_o = 8\text{ A}$	$R_{\text{SET}} = 130\ \Omega$ , $V_o = 1.8\text{ V}$		89		%
			$R_{\text{SET}} = 3.57\ \text{k}\Omega$ , $V_o = 1.5\text{ V}$		88		
			$R_{\text{SET}} = 12.1\ \text{k}\Omega$ , $V_o = 1.2\text{ V}$		86		
			$R_{\text{SET}} = 32.4\ \text{k}\Omega$ , $V_o = 1\text{ V}$		84		
			$R_{\text{SET}} = \text{OPEN}$ , $V_o = 0.8\text{ V}$		82		
$V_r$	$V_o$ ripple (peak-to-peak)	20 MHz bandwidth	$V_o \leq 1\text{ V}$		25		mVpp
			$V_o \leq 1\text{ V}$		1		$\%V_o$
$I_o\ \text{trip}$	Overcurrent threshold	Reset, followed by auto-recovery			20		A
$t_{\text{tr}}$	Transient response	1 A/ $\mu\text{s}$ load step, 50 to 100 $\% I_o\ \text{max}$ , $C_o = 330\ \mu\text{F}$					
			Recovery Time		70		$\mu\text{Sec}$
			$V_o$ over/undershoot		100		mV
$V_o\ \text{adj}$	Margin up/down adjust				$\pm 5\%$		
$I_{\text{IL}}\ \text{margin}$	Margin input current (pins 9 /10)	Pin to GND			$-8$ <sup>(14)</sup>		$\mu\text{A}$

- (12) See SOA curves or consult factory for appropriate derating.
- (13) The set-point voltage tolerance is affected by the tolerance and stability of  $R_{\text{SET}}$ . The stated limit is unconditionally met if  $R_{\text{SET}}$  has a tolerance of 1%, with 100 ppm/ $^\circ\text{C}$  (or better) temperature stability.
- (14) A small, low-leakage (<100 nA) MOSFET is recommended to control this pin. The open-circuit voltage is less than 1  $V_{\text{dc}}$ .

**ELECTRICAL CHARACTERISTICS (continued)**

$T_A = 25^\circ\text{C}$ ,  $V_i = 12\text{ V}$ ,  $V_O = 1.8\text{ V}$ ,  $C_i = 560\ \mu\text{F}$ ,  $C_O = 0\ \mu\text{F}$ , and  $I_O = I_{O\text{max}}$  (Unless otherwise stated)

CHARACTERISTICS		CONDITIONS		PTH12010L			UNIT
				MIN	TYP	MAX	
$I_{IL\text{ track}}$	Track input current (pin 8)	Pin to GND				-0.13 <sup>(15)</sup>	mA
$dV_{\text{track}}/dt$	Track slew rate capability	$C_O \leq C_{O(\text{max})}$				1	V/ms
UVLO	Undervoltage lockout	$V_i$ increasing			9.5	10.4	V
		$V_i$ decreasing		8.8	9		
$V_{IH}$	Inhibit control (pin3)	Referenced to GND					V
$V_{iL}$	Input high voltage			$V_i - 0.5$	Open <sup>(4)</sup>		
$V_{iL}$	Input low voltage			-0.2		0.5	
$I_{iL}$	Input low current	Pin to GND			0.24		mA
$I_i\text{ inh}$	Input standby current	Inhibit (pin 3) to GND, Track (pin 8) open			10		mA
$f_s$	Switching frequency	Over $V_i$ and $I_o$ ranges		200	250	300	kHz
$C_i$	External input capacitance			560 <sup>(16)</sup>			$\mu\text{F}$
$C_O$	External output capacitance	Capacitance value	nonceramic	0	330 <sup>(17)</sup>	6,600 <sup>(18)</sup>	$\mu\text{F}$
			ceramic	0		300	
		Equivalent series resistance (nonceramic)		4 <sup>(19)</sup>			$\text{m}\Omega$
MTBF	Reliability	Per Bellcore TR-332		6.4			$10^6\text{ Hrs}$
		50% stress, $T_a = 40^\circ\text{C}$ , ground benign					

(15) This control pin has an internal pull-up to the input voltage  $V_i$  (7.5 V for pin 8). If it is left open-circuit the module operates when input power is applied. A small, low-leakage (<100 nA) MOSFET or open-drain/collector voltage supervisor IC is recommended for control. Do not place an external pull-up on this pin. For further information, see the related application section.

(16) A 560  $\mu\text{F}$  electrolytic input capacitor is required for proper operation. The capacitor must be rated for a minimum of 800 mA rms of ripple current.

(17) An external output capacitor is not required for basic operation. Adding 330  $\mu\text{F}$  of distributed capacitance at the load improves the transient response.

(18) This is the calculated maximum. The minimum ESR limitation often results in a lower value. When controlling the Track pin using a voltage supervisor,  $C_{O(\text{max})}$  is reduced to 3300  $\mu\text{F}$ . See the application notes for further guidance.

(19) This is the typical ESR for all the electrolytic (nonceramic) output capacitance. Use 7  $\text{m}\Omega$  as the minimum when using max-ESR values to calculate.

DEVICE INFORMATION

TERMINAL FUNCTIONS

TERMINAL		DESCRIPTION
NAME	NO.	
GND	1,7	This is the common ground connection for the $V_I$ and $V_O$ power connections. It is also the 0 $V_{dc}$ reference for the control inputs.
$V_I$	2	The positive input voltage power node to the module, which is referenced to common GND.
Inhibit <sup>(20)</sup>	3	The Inhibit pin is an open-collector/drain negative logic input that is referenced to <i>GND</i> . Applying a low-level ground signal to this input disables the module's output and turns off the output voltage. When the <i>Inhibit</i> control is active, the input current drawn by the regulator is significantly reduced. If the inhibit feature is not used, the control pin should be left open-circuit. The module then produces an output whenever a valid input source is applied.
$V_O$ Adjust	4	A 1% resistor must be directly connected between this pin and <i>GND</i> (pin 1) to set the output voltage of the module higher than its lowest value. The temperature stability of the resistor should be 100 ppm/°C (or better). The set-point range is 1.2 V to 5.5 V for W-suffix devices, and 0.8 V to 1.8 V for L-suffix devices. The resistor value required for a given output voltage may be calculated using a formula. If left open circuit, the output voltage defaults to its lowest value. For further information on output voltage adjustment, see the related application section. The specification table gives the preferred resistor values for a number of standard output voltages.
$V_O$ Sense	5	The sense input allows the regulation circuit to compensate for voltage drop between the module and the load. For optimal voltage accuracy, <i>V_O Sense</i> should be connected to $V_O$ . It can also be left disconnected.
$V_O$	6	The regulated positive power output with respect to the GND node.
Track	8	This is an analog control input that enables the output voltage to follow an external voltage. This pin becomes active typically 20 ms after the input voltage has been applied, and allows direct control of the output voltage from 0 V up to the nominal set-point voltage. Within this range the output will follow the voltage at the <i>Track</i> pin on a volt-for-volt basis. When the control voltage is raised above this range, the module regulates at its set-point voltage. The feature allows the output voltage to rise simultaneously with other modules powered from the same input bus. If unused, this input should be connected to $V_I$ . <i>Note: Due to the undervoltage lockout feature, the output of the module cannot follow its own input voltage during power up.</i>
Margin Down <sup>(1)</sup>	9	When this input is asserted to <i>GND</i> , the output voltage is decreased by 5% from the nominal. The input requires an open-collector (open-drain) interface. It is not TTL compatible. A lower percent change can be accommodated with a series resistor. For further information, see the related application section.
Margin Up <sup>(1)</sup>	10	When this input is asserted to <i>GND</i> , the output voltage is increased by 5%. The input requires an open-collector (open-drain) interface. It is not TTL compatible. The percent change can be reduced with a series resistor. For further information, see the related application section.

(20) Denotes negative logic:  
 Open = Normal operation  
 Ground = Function active

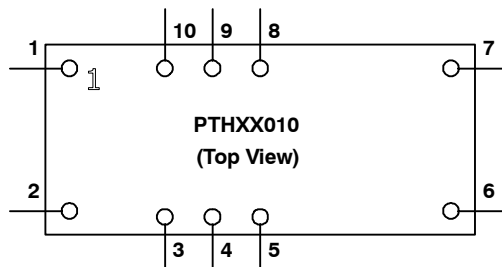

PTH12010W TYPICAL CHARACTERISTICS ( $V_I = 12\text{ V}$ )<sup>(21)</sup> <sup>(22)</sup>

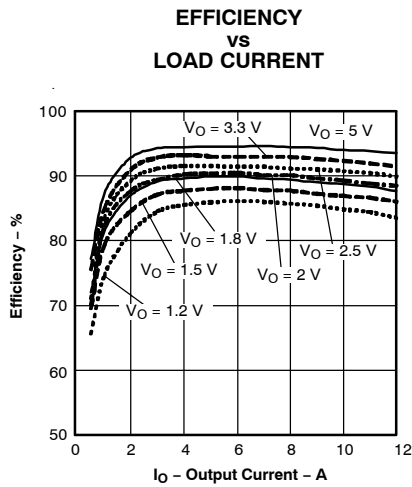

Figure 1.

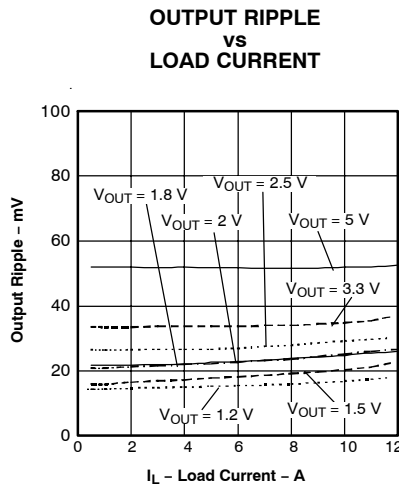

Figure 2.

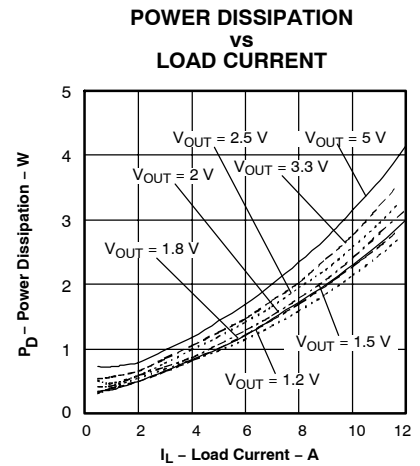

Figure 3.

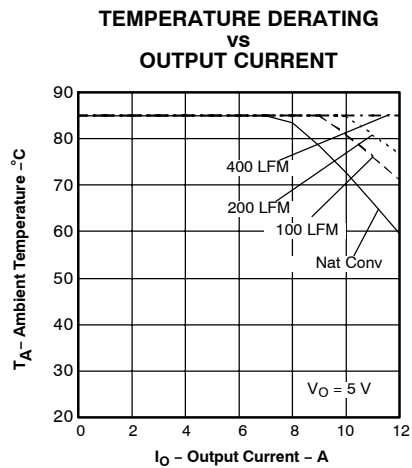

Figure 4.

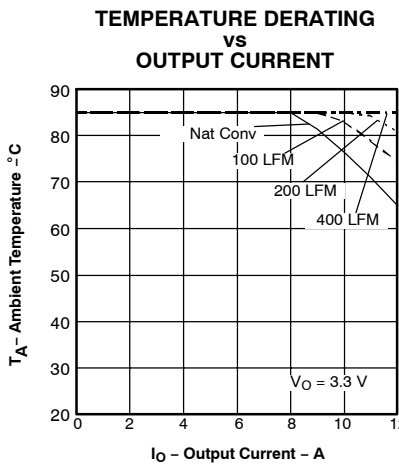

Figure 5.

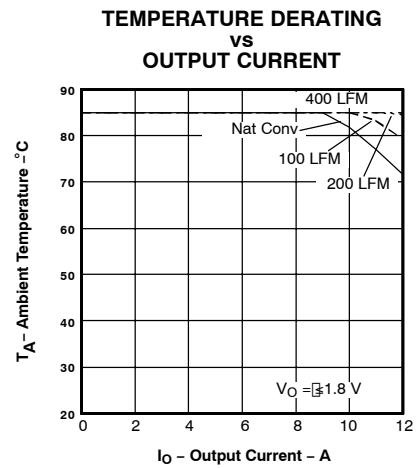

Figure 6.

- (21) The electrical characteristic data has been developed from actual products tested at 25°C. This data is considered typical for the converter. Applies to [Figure 1](#), [Figure 2](#), and [Figure 3](#).
- (22) The temperature derating curves represent the conditions at which internal components are at or below the manufacturer's maximum operating temperatures. Derating limits apply to modules soldered directly to a 4 inch × 4 inch double-sided PCB with 2 oz. copper. For surface mount packages (AS and AZ suffix), multiple vias (plated through holes) are required to add thermal paths around the power pins. Please refer to the mechanical specification for more information. Applies to [Figure 4](#), [Figure 5](#), and [Figure 6](#).

PTH12010L TYPICAL CHARACTERISTICS ( $V_I = 12\text{ V}$ ) <sup>(25)</sup> <sup>(26)</sup>

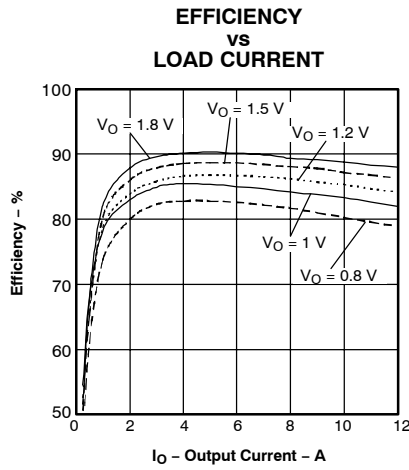

Figure 7.

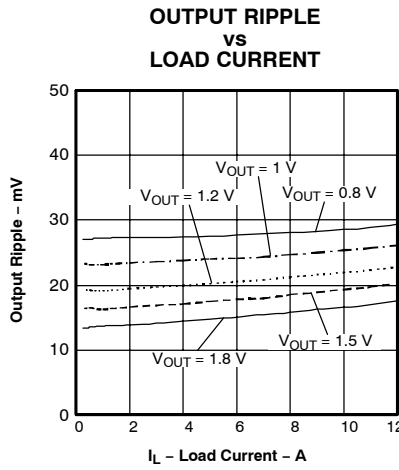

Figure 8.

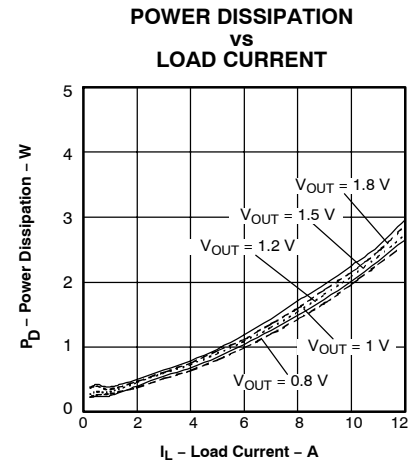

Figure 9.

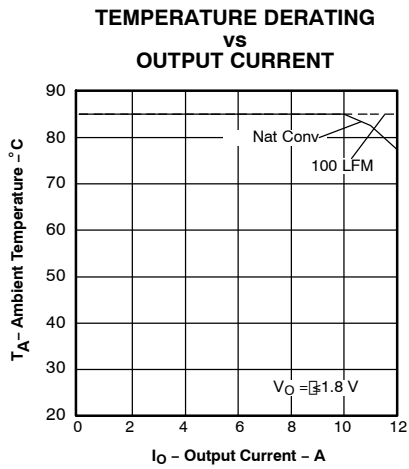

Figure 10.

- (25) The electrical characteristic data has been developed from actual products tested at 25°C. This data is considered typical for the converter. Applies to [Figure 7](#), [Figure 8](#), and [Figure 9](#).
- (26) The temperature derating curves represent the conditions at which internal components are at or below the manufacturer's maximum operating temperatures. Derating limits apply to modules soldered directly to a 4 inch x 4 inch double-sided PCB with 2 oz. copper. For surface mount packages (AS and AZ suffix), multiple vias (plated through holes) are required to add thermal paths around the power pins. Please refer to the mechanical specification for more information. Applies to [Figure 10](#).

## APPLICATION INFORMATION

### CAPACITOR RECOMMENDATIONS FOR THE PTH12010 SERIES OF POWER MODULES

#### INPUT CAPACITOR

The recommended input capacitance is determined by the 560  $\mu\text{F}$  minimum capacitance and 800 mArms minimum ripple current rating. A 10  $\mu\text{F}$  X5R/X7R ceramic capacitor may also be added to reduce the reflected input ripple current. The ceramic capacitor should be located between the input electrolytic and the module.

Ripple current, less than 100 m $\Omega$  equivalent series resistance (ESR) and temperature are major considerations when selecting input capacitors. Unlike polymer-tantalum capacitors, regular tantalum capacitors have a recommended minimum voltage rating of  $2 \times$  (max dc voltage + ac ripple). This is standard practice to ensure reliability. No tantalum capacitors were found with sufficient voltage rating to meet this requirement. At temperatures below 0°C, the ESR of aluminum electrolytic capacitors increases. For these applications, Os-Con, polymer-tantalum, and polymer-aluminum types should be considered.

#### OUTPUT CAPACITORS (OPTIONAL)

For applications with load transients (sudden changes in load current), regulator response benefits from external output capacitance. The value of 330  $\mu\text{F}$  is used to define the transient response specification (see data sheet). For most applications, a high quality computer-grade aluminum electrolytic capacitor is adequate. These capacitors provide decoupling over the frequency range, 2 kHz to 150 kHz, and are suitable for ambient temperatures above 0°C. Below 0°C, tantalum, ceramic or Os-Con type capacitors are recommended. When using one or more nonceramic capacitors, the calculated equivalent ESR should be no lower than 4 m $\Omega$  (7 m $\Omega$  using the manufacturer's maximum ESR for a single capacitor). A list of preferred low-ESR type capacitors are identified in [Table 1](#).

In addition to electrolytic capacitance, adding a 10  $\mu\text{F}$  X5R/X7R ceramic capacitor to the output reduces the output ripple voltage and improve the regulator's transient response. The measurement of both the output ripple and transient response is also best achieved across a 10  $\mu\text{F}$  ceramic capacitor.

#### CERAMIC CAPACITORS

Above 150 kHz the performance of aluminum electrolytic capacitors is less effective. Multilayer ceramic capacitors have very low ESR and a resonant frequency higher than the bandwidth of the regulator. They can be used to reduce the reflected ripple current at the input as well as improve the transient response of the output. When used on the output, their combined ESR is not critical as long as the total value of ceramic capacitance does not exceed 300  $\mu\text{F}$ . Also, to prevent the formation of local resonances, do not place more than five identical ceramic capacitors in parallel with values of 10  $\mu\text{F}$  or greater.

#### TANTALUM CAPACITORS

Tantalum type capacitors are most suited for use on the output bus, and are recommended for applications where the ambient operating temperature can be less than 0°C. The AVX TPS, Sprague 593D/594/595 and Kemet T495/T510 capacitor series are suggested over other tantalum types due to their higher rated surge, power dissipation, and ripple current capability. As a caution, many general purpose tantalum capacitors have considerably higher ESR, reduced power dissipation and lower ripple current capability. These capacitors are also less reliable as they have lower power dissipation and surge current ratings. Tantalum capacitors that do not have a stated ESR or surge current rating are not recommended for power applications.

When specifying Os-con and polymer tantalum capacitors for the output, the minimum ESR limit are encountered well before the maximum capacitance value is reached.

#### CAPACITOR TABLE

[Table 1](#) identifies the characteristics of capacitors from a number of vendors with acceptable ESR and ripple current (rms) ratings. The recommended number of capacitors required at both the input and output buses is identified for each capacitor type.

*This is not an extensive capacitor list. Capacitors from other vendors are available with comparable specifications. Those listed are for guidance. The RMS ripple current rating and ESR (at 100 kHz) are critical parameters necessary to insure both optimum regulator performance and long capacitor life.*

**APPLICATION INFORMATION (continued)**

**DESIGNING FOR VERY FAST LOAD TRANSIENTS**

The transient response of the DC/DC converter has been characterized using a load transient with a di/dt of 1 A/μs. The typical voltage deviation for this load transient is given in the data sheet specification table using the optional value of output capacitance. As the di/dt of a transient is increased, the response of a converter's regulation circuit ultimately depends on its output capacitor decoupling network. This is an inherent limitation with any dc/dc converter once the speed of the transient exceeds its bandwidth capability. If the target application specifies a higher di/dt or lower voltage deviation, the requirement can only be met with additional output capacitor decoupling. In these cases special attention must be paid to the type, value and ESR of the capacitors selected.

If the transient performance requirements exceed that specified in the data sheet, or the total amount of load capacitance is above 3000 μF, the selection of output capacitors becomes more important.

**Table 1. Input/Output Capacitors<sup>(29)</sup>**

CAPACITOR VENDOR, TYPE/SERIES, (STYLE)	CAPACITOR CHARACTERISTICS					QUANTITY		VENDOR PART NUMBER
	WORKING VOLTAGE	VALUE (μF)	MAX. ESR AT 100 kHz	MAX RIPPLE CURRENT AT 85°C (Irms)	PHYSICAL SIZE (mm)	INPUT BUS	OPTIONAL OUTPUT BUS	
Panasonic, Aluminum (FC)	25 V	560	0.065 Ω	1205 mA	12,5 x 15	1	1	EEUFC1E561S
FC, Radial	25 V	1000	0.060 Ω	1100 mA	12,5 x 13,5	1	1	EEVFK1E102Q
FK, (SMD)	35 V	680	0.060 Ω	1100 mA	12,5 x 13,5	1	1	EEVFK1V681Q
United Chemi-Con PS, Poly-Aluminum (Radial)	16 V	330	0.014 Ω	5050 mA	10 x 12,5	2	≤2	16PS330MJ12
LXZ, Aluminium (Radial)	16 V	680	0.068 Ω	1050 mA	10 x 16	1	1	LXZ16VB681M10X16LL
PXA, Poly-Aluminum (SMD)	16 V	330	0.014 Ω	5050 mA	10 x 12,2	2	≤2	PXA16VC331MJ12TP
Nichicon, Aluminum (PM)	25 V	560	0.060 Ω	1060 mA	12,5 x 15	1	1	UPM1E561MHH6
HD, (Radial)	16 V	680	0.038 Ω	1430 mA	10 x 16	1	1	UHD1C681MPR
PM, (Radial)	35 V	560	0.048 Ω	1360 mA	16 x 15	1	1	UPM1V561MHH6
Panasonic, Poly-Aluminum S/SE, (SMD)Poly-Aluminum	6.3 V	180	0.005 Ω	4000 mA	7,3 x 4,3 x 4,2	N/R <sup>(30)</sup>	≤1 <sup>(31)</sup>	EEFSEOJ181R (V <sub>O</sub> ≤ 5.1 V)
Sanyo TPE Poscap (SMD)	10 V	330	0.025 Ω	3000 mA	7,3 x 5,7	N/R <sup>(2)</sup>	≤4	10TPE330M
SEQP, Os-Con (Radial)	16 V	330	0.016 Ω	>4720 mA	10 x 13	2	≤2	16SEQP330M
SVP, Os-Con (SMD)	16 V	330	0.016 Ω	4700 mA	11 x 12	2	≤3	16SVP330M
AVX, Tantalum Series III TPS (SMD)	10 V	470	0.045 Ω	>1723 mA	7,3 x 5,7 x 4,1	N/R <sup>(2)</sup>	≤5 <sup>(3)</sup>	TPSE477M010R0045 (V <sub>O</sub> ≤ 5.1 V)
	10 V	330	0.045 Ω	>1723 mA		N/R <sup>(2)</sup>	≤5 <sup>(3)</sup>	TPSE377M010R0045 (V <sub>O</sub> ≤ 5.1 V)
Kemet								

**(29) Capacitor Supplier Verification**

Please verify availability of capacitors identified in this table. Capacitor suppliers may recommend alternative part numbers because of limited availability or obsolete products. In some instances, the capacitor product life cycle may be in decline and have short-term consideration for obsolescence.

**RoHS, Lead-free and Material Details**

Please consult capacitor suppliers regarding material composition, RoHS status, lead-free status, and manufacturing process requirements. Component designators or part number deviations can occur when material composition or soldering requirements are updated.

(30) N/R –Not recommended. The capacitor voltage rating does not meet the minimum derated operating limits.

(31) The voltage rating of this capacitor only allows it to be used for output voltages that are equal to or less than 5.1 V.

**APPLICATION INFORMATION (continued)**

**Table 1. Input/Output Capacitors (continued)**

CAPACITOR VENDOR, TYPE/SERIES, (STYLE)	CAPACITOR CHARACTERISTICS					QUANTITY		VENDOR PART NUMBER
	WORKING VOLTAGE	VALUE ( $\mu$ F)	MAX. ESR AT 100 kHz	MAX RIPPLE CURRENT AT 85°C (Irms)	PHYSICAL SIZE (mm)	INPUT BUS	OPTIONAL OUTPUT BUS	
T520, Poly-Tantalum (SMD)	10 V	330	0.040 $\Omega$	1800 mA		N/R <sup>(2)</sup>	$\leq 5$	T520X337M010AS
T530, Poly-Tant/Organic	10 V	330	0.010 $\Omega$	>3800 mA	4,3 x 7,3 x 4,0	N/R <sup>(2)</sup>	$\leq 2$	T530X337M010ASE010
	6.3 V	470	0.005 $\Omega$	4200 mA		N/R <sup>(2)</sup>	$\leq 1$ <sup>(3)</sup>	T530X477M006AS E005 ( $V_O \leq 5.1$ V)
Vishay-Sprague								
595D, Tantalum (SMD)	10 V	470	0.100 $\Omega$	1440 mA	7,2 x 6,0 x 4,1	N/R <sup>(2)</sup>	$\leq 5$ <sup>(3)</sup>	595D477X0010R2T ( $V_O \leq 5.1$ V)
94SA, Os-con (Radial)	16 V	1000	0.015 $\Omega$	9750 mA	16 x 25	1	$\leq 2$	94SA108X0016HBP
94SVP, Os-CON(SMD)	16V	330	0.017 $\Omega$	4580 mA	10 x 12,7	2 <sup>(32)</sup>	$\leq 2$	94SVP337X0016F12
Kemet, Ceramic X5R (SMD)	16 V	10	0.002 $\Omega$	-	1210 Case	1 <sup>(33)</sup>	$\leq 5$	C1210C106M4PAC
	6.3 V	47	0.002 $\Omega$		3225 mm	N/R <sup>(2)</sup>	$\leq 5$	C1210C476K9PAC
Murata, Ceramic X5R (SMD)	6.3 V	100	0.002 $\Omega$	-	1210 Case	N/R <sup>(2)</sup>	$\leq 3$	GRM32ER60J107M
	16 V	47			3225 mm	1 <sup>(5)</sup>	$\leq 5$	GRM32ER61CJ476K
	16 V	22				1 <sup>(5)</sup>	$\leq 5$	GRM32ER61C226K
	16 V	10				1 <sup>(5)</sup>	$\leq 5$	GRM32DR61C106K
TDK, Ceramic X5R (SMD)	6.3 V	100	0.002 $\Omega$	-	1210 Case	N/R <sup>(2)</sup>	$\leq 3$	C3225X5R0J107MT
	6.3 V	47			3225 mm	N/R <sup>(34)</sup>	$\leq 5$	C3225X5R0J476MT
	16 V	22				1 <sup>(35)</sup>	$\leq 5$	C3225X5R1C226MT
	16 V	10				1 <sup>(7)</sup>	$\leq 5$	C3225X5R1C106MT

(32) A total capacitance of 540  $\mu$ F is acceptable based on the combined ripple current rating.

(33) A ceramic capacitor may be used to complement electrolytic types at the input to further reduce high-frequency ripple current.

(34) N/R –Not recommended. The capacitor voltage rating does not meet the minimum derated operating limits.

(35) A ceramic capacitor may be used to complement electrolytic types at the input to further reduce high-frequency ripple current.

### ADJUSTING THE OUTPUT VOLTAGE OF THE PTH12010X SERIES OF WIDE-OUTPUT ADJUST POWER MODULES

The  $V_O$  Adjust control (pin 4) sets the output voltage of the PTH12010 product. The adjustment range is from 1.2 V to 5.5 V for the W-suffix modules, and 0.8 V to 1.8 V for L-suffix modules. The adjustment method requires the addition of a single external resistor,  $R_{SET}$ , that must be connected directly between the  $V_O$  Adjust and GND pins. Table 2 gives the preferred value of the external resistor for a number of standard voltages, along with the actual output voltage that this resistance value provides. Figure 11 shows the placement of the required resistor.

**Table 2. Preferred Values of  $R_{set}$  for Standard Output Voltages**

$V_O$ (Required)	PTH12010W		PTH12010L	
	$R_{SET}$	$V_O$ (Actual)	$R_{SET}$	$V_O$ (Actual)
5 V	280 $\Omega$	5.009 V	N/A	N/A
3.3 V	2.0 k $\Omega$	3.294 V	N/A	N/A
2.5 V	4.32 k $\Omega$	2.503 V	N/A	N/A
2 V	8.06 k $\Omega$	2.010 V	N/A	N/A
1.8 V	11.5 k $\Omega$	1.081 V	130 $\Omega$	1.800 V
1.5 V	24.3 k $\Omega$	1.506 V	3.57 k $\Omega$	1.499 V
1.2 V	Open	1.200 V	12.1 k $\Omega$	1.201 V
1.1 V	N/A	N/A	18.7 k $\Omega$	1.101 V
1.0 V	N/A	N/A	32.4 k $\Omega$	0.999 V
0.9 V	N/A	N/A	71.5 k $\Omega$	0.901 V
0.8 V	N/A	N/A	Open	0.800 V

For other output voltages, the value of the required resistor can either be calculated, or simply selected from the range of values given in Table 4. The following formula may be used for calculating the adjust resistor value. Select the appropriate value for the parameters,  $R_S$  and  $V_{min}$ , from Table 3.

$$R_{SET} = 10 \text{ k}\Omega \times \frac{0.8 \text{ V}}{V_O - V_{min}} - R_S \text{ k}\Omega \tag{1}$$

**Table 3. Adjust Formula Parameters**

PT. NO.	PTH12010W	PTH12010L
$V_{min}$	1.2 V	0.8 V
$V_{max}$	5.5 V	1.8 V
$R_S$	1.82 k $\Omega$	7.87 k $\Omega$

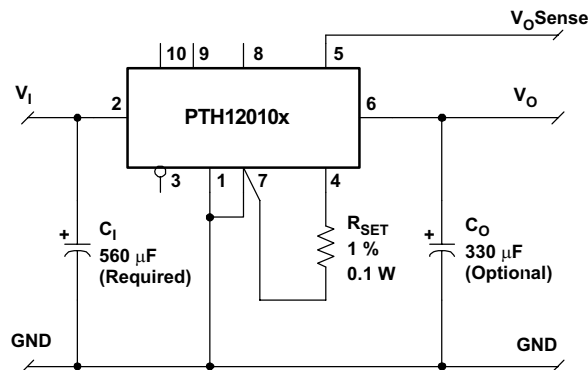

**Figure 11.  $V_O$  Adjust Resistor Placement**

**NOTES**

1. A 0.05 W rated resistor may be used. The tolerance should be 1%, with temperature stability of 100 ppm/ $^{\circ}$ C (or better). Place the resistor as close to the regulator as possible. Connect the resistor directly between

pins 4 and 7 using dedicated PCB traces.

- Never connect capacitors from  $V_O$  Adjust to either  $GND$  or  $V_O$ . Any capacitance added to the  $V_O$  Adjust pin affects the stability of the regulator.

**Table 4. Output Voltage Set-Point Resistor Values**

PTH12010W				PTH12010L	
$V_O$	$R_{SET}$	$V_O$	$R_{SET}$	$V_O$	$R_{SET}$
1.2	Open	2.7	3.51 k $\Omega$	0.8	Open
1.225	318 k $\Omega$	2.75	3.34 k $\Omega$	0.825	312 k $\Omega$
1.25	158 k $\Omega$	2.8	3.18 k $\Omega$	0.85	152 k $\Omega$
1.275	105 k $\Omega$	2.85	3.03 k $\Omega$	0.875	98.8 k $\Omega$
1.3	78.2 k $\Omega$	2.9	2.89 k $\Omega$	0.9	72.1 k $\Omega$
1.325	62.2 k $\Omega$	2.95	2.75 k $\Omega$	0.925	56.1 k $\Omega$
1.35	51.5 k $\Omega$	3	2.62 k $\Omega$	0.95	45.5 k $\Omega$
1.375	43.9 k $\Omega$	3.05	2.5 k $\Omega$	0.975	37.8 k $\Omega$
1.4	38.2 k $\Omega$	3.1	2.39 k $\Omega$	1	32.1 k $\Omega$
1.425	33.7 k $\Omega$	3.15	2.28 k $\Omega$	1.025	27.7 k $\Omega$
1.45	30.2 k $\Omega$	3.2	2.18 k $\Omega$	1.05	24.1 k $\Omega$
1.475	27.3 k $\Omega$	3.25	2.08 k $\Omega$	1.075	21.2 k $\Omega$
1.5	24.8 k $\Omega$	3.3	1.99 k $\Omega$	1.1	18.8 k $\Omega$
1.55	21 k $\Omega$	3.35	1.90 k $\Omega$	1.125	16.7 k $\Omega$
1.6	18.2 k $\Omega$	3.4	1.82 k $\Omega$	1.15	15 k $\Omega$
1.65	16 k $\Omega$	3.5	1.66 k $\Omega$	1.175	13.5 k $\Omega$
1.7	14.2 k $\Omega$	3.6	1.51 k $\Omega$	1.2	12.1 k $\Omega$
1.75	12.7 k $\Omega$	3.7	1.38 k $\Omega$	1.225	11 k $\Omega$
1.8	11.5 k $\Omega$	3.8	1.26 k $\Omega$	1.25	9.91 k $\Omega$
1.85	10.5 k $\Omega$	3.9	1.14 k $\Omega$	1.275	8.97 k $\Omega$
1.9	9.61 k $\Omega$	4	1.04 k $\Omega$	1.3	8.13 k $\Omega$
1.95	8.85 k $\Omega$	4.1	939 $\Omega$	1.325	7.37 k $\Omega$
2	8.18 k $\Omega$	4.2	847 $\Omega$	1.35	6.68 k $\Omega$
2.05	7.59 k $\Omega$	4.3	761 $\Omega$	1.375	6.04 k $\Omega$
2.1	7.07 k $\Omega$	4.4	680 $\Omega$	1.4	5.46 k $\Omega$
2.15	6.6 k $\Omega$	4.5	604 $\Omega$	1.425	4.93 k $\Omega$
2.2	6.18 k $\Omega$	4.6	533 $\Omega$	1.45	4.44 k $\Omega$
2.25	5.80 k $\Omega$	4.7	466 $\Omega$	1.475	3.98 k $\Omega$
2.3	5.45 k $\Omega$	4.8	402 $\Omega$	1.5	3.56 k $\Omega$
2.35	5.14 k $\Omega$	4.9	342 $\Omega$	1.55	2.8 k $\Omega$
2.4	4.85 k $\Omega$	5	285 $\Omega$	1.6	2.13 k $\Omega$
2.45	4.58 k $\Omega$	5.1	231 $\Omega$	1.65	1.54 k $\Omega$
2.5	4.33 k $\Omega$	5.2	180 $\Omega$	1.7	1.02 k $\Omega$
2.55	4.11 k $\Omega$	5.3	131 $\Omega$	1.75	551 $\Omega$
2.6	3.89 k $\Omega$	5.4	85 $\Omega$	1.8	130 $\Omega$
2.65	3.70k $\Omega$	5.5	41 $\Omega$		

## FEATURES OF THE PTH FAMILY OF NON-ISOLATED WIDE OUTPUT ADJUST POWER MODULES

### POLA™ COMPATIBILITY

The PTH/PTV family of nonisolated, wide-output adjustable power modules are optimized for applications that require a flexible, high performance module that is small in size. Each of these products are POLA™ compatible. POLA compatible products are produced by a number of manufacturers, and offer customers advanced, nonisolated modules with the same footprint and form factor. POLA parts are also ensured to be interoperable, thereby providing customers with second-source availability.

From the basic, *Just Plug it In* functionality of the 6-A modules, to the 30-A rated feature-rich PTHxx030, these products were designed to be very flexible, yet simple to use. The features vary with each product. [Table 5](#) provides a quick reference to the features by product series and input bus voltage.

**Table 5. Operating Features by Series and Input Bus Voltage**

Series	Input Bus	I <sub>o</sub>	Adjust (Trim)	On/Off Inhibit	Over-Current	Prebias Startup	Auto-Track™	Margin Up/Down	Output Sense	Thermal Shutdown
PTHxx050	3.3 V	6 A	•	•	•	•	•			
	5 V	6 A	•	•	•	•	•			
	12 V	6 A	•	•	•	•	•			
PTHxx060	3.3 V / 5 V	10 A	•	•	•	•	•	•	•	
	12 V	8 A	•	•	•	•	•	•	•	
PTHxx010	3.3 V / 5 V	15 A	•	•	•	•	•	•	•	
	12 V	12 A	•	•	•	•	•	•	•	
PTVxx010	5 V	8 A	•	•	•	•	•		•	
	12 V	8 A	•	•	•	•	•		•	
PTHxx020	3.3 V / 5 V	22 A	•	•	•	•	•	•	•	•
	12 V	18 A	•	•	•	•	•	•	•	•
PTVxx020	5 V	18 A	•	•	•	•	•		•	•
	12 V	16 A	•	•	•	•	•		•	•
PTHxx030	3.3 V / 5 V	30 A	•	•	•	•	•	•	•	•
	12 V	26 A	•	•	•	•	•	•	•	•

For simple point-of-use applications, the PTH12050 (6 A) provides operating features such as an on/off inhibit, output voltage trim, prebias start-up and overcurrent protection. The PTH12060 (10 A), and PTH12010 (12 A) include an output voltage sense, and margin up/down controls. Then the higher output current, PTH12020 (18 A) and PTH12030 (26 A) products incorporate overtemperature shutdown protection.

The PTV12010 and PTV12020 are similar parts offered in a vertical, single in-line pin (SIP) profile, at slightly lower current ratings.

All of the products referenced in [Table 5](#) include Auto-Track™. This feature was specifically designed to simplify the task of sequencing the supply voltages in a power system. This and other features are described in the following sections.

### SOFT-START POWER UP

The Auto-Track feature allows the power-up of multiple PTH modules to be directly controlled from the *Track* pin. However in a stand-alone configuration, or when the Auto-Track feature is not being used, the *Track* pin should be directly connected to the input voltage,  $V_i$ , see [Figure 12](#).

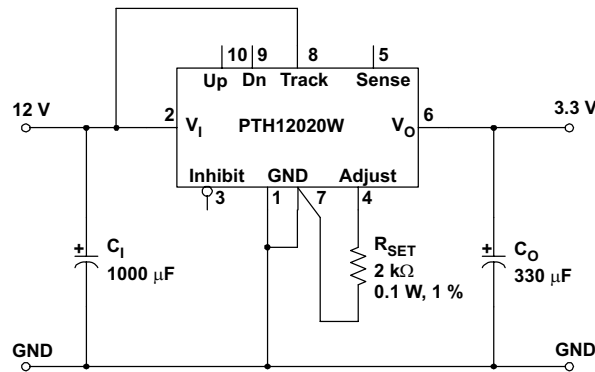

**Figure 12. Power-Up Application Circuit**

When the *Track* pin is connected to the input voltage the Auto-Track function is permanently disengaged. This allows the module to power up entirely under the control of its internal soft-start circuitry. When power up is under soft-start control, the output voltage rises to the set-point at a quicker and more linear rate.

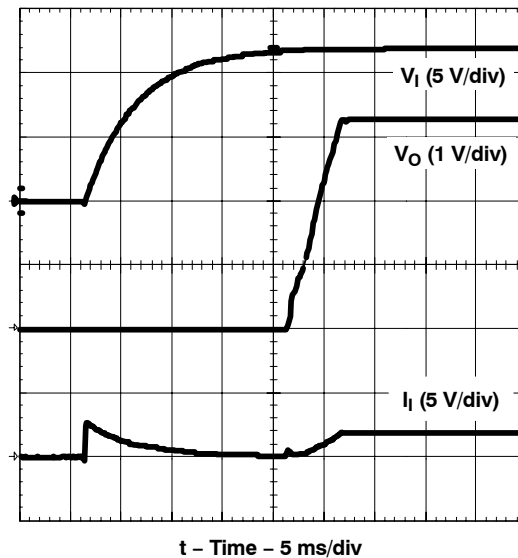

**Figure 13. Power-Up Waveforms**

From the moment a valid input voltage is applied, the soft-start control introduces a short time delay (typically 8 ms-15 ms) before allowing the output voltage to rise. The output then progressively rises to the module's setpoint voltage. [Figure 13](#) shows the soft-start power-up characteristic of the 18-A output product (PTH12020W), operating from a 12-V input bus and configured for a 3.3-V output. The waveforms were measured with a 5-A resistive load and the Auto-Track feature disabled. The initial rise in input current when the input voltage first starts to rise is the charge current drawn by the input capacitors. Power-up is complete within 25 ms.

## OVERCURRENT PROTECTION

For protection against load faults, all modules incorporate output overcurrent protection. Applying a load that exceeds the regulator's overcurrent threshold causes the regulated output to shut down. Following shutdown a module periodically attempts to recover by initiating a soft-start power-up. This is described as a *hiccup* mode of operation, whereby the module continues in a cycle of successive shutdown and power up until the load fault is removed. During this period, the average current flowing into the fault is significantly reduced. Once the fault is removed, the module automatically recovers and returns to normal operation.

**OUTPUT ON/OFF INHIBIT**

Inhibit for applications requiring output voltage on/off control, each series of the PTH family incorporates an output *Inhibit* control pin. The inhibit feature can be used wherever there is a requirement for the output voltage from the regulator to be turned off.

The power modules function normally when the *Inhibit* pin is left open-circuit, providing a regulated output whenever a valid source voltage is connected to  $V_I$  with respect to GND.

Figure 14 shows the typical application of the inhibit function. Note the discrete transistor (Q1). The *Inhibit* input has its own internal pull-up to a potential of 5 V to 13.2 V (see footnotes to specification table). The input is not compatible with TTL logic devices. An open-collector (or open-drain) discrete transistor is recommended for control.

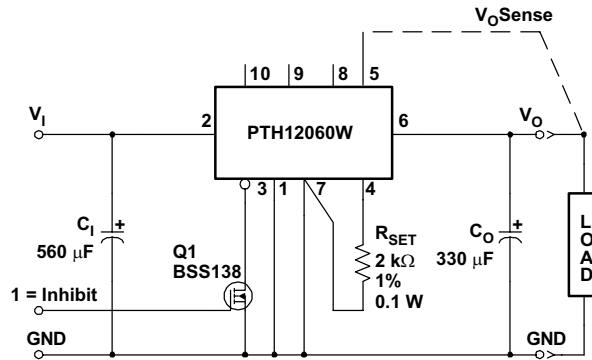

**Figure 14. Inhibit Control Circuit**

Turning Q1 on applies a low voltage to the Inhibit control pin and disables the output of the module. If Q1 is then turned off, the module executes a soft-start power-up sequence. A regulated output voltage is produced within 25 ms Figure 15 shows the typical rise in both the output voltage and input current, following the turn-off of Q1. The turn off of Q1 corresponds to the rise in the waveform, Q1  $V_{ds}$ . The waveforms were measured with a 5-A constant current load.

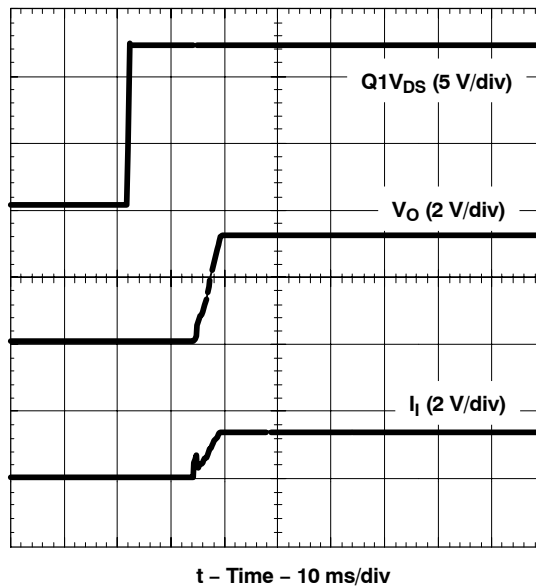

**Figure 15. Power-Up from Inhibit Control**

## Auto-Track™ Function

The Auto-Track function is unique to the PTH/PTV family, and is available with all POLA products. Auto-Track was designed to simplify the amount of circuitry required to make the output voltage from each module power up and power down in sequence. The sequencing of two or more supply voltages during power up is a common requirement for complex mixed-signal applications that use dual-voltage VLSI ICs such as the TMS320™ DSP family, microprocessors, and ASICs.

### How Auto-Track™ Works

Auto-Track works by forcing the module output voltage to follow a voltage presented at the *Track* control pin <sup>(1)</sup>. This control range is limited to between 0 V and the module set-point voltage. Once the *Track* pin voltage is raised above the set-point voltage, the module output remains at its set-point <sup>(2)</sup>. As an example, if the *Track* pin of a 2.5-V regulator is at 1 V, the regulated output is 1 V. If the voltage at the *Track* pin rises to 3 V, the regulated output does not go higher than 2.5 V.

When under Auto-Track control, the regulated output from the module follows the voltage at its *Track* pin on a volt-for-volt basis. By connecting the *Track* pin of a number of these modules together, the output voltages follow a common signal during power up and power down. The control signal can be an externally generated master ramp waveform, or the output voltage from another power supply circuit <sup>(3)</sup>. For convenience, the *Track* input incorporates an internal RC-charge circuit. This operates off the module input voltage to produce a suitable rising waveform at power up.

### Typical Application

The basic implementation of Auto-Track allows for simultaneous voltage sequencing of a number of Auto-Track compliant modules. Connecting the *Track* inputs of two or more modules forces their *Track* input to follow the same collective RC-ramp waveform, and allows their power-up sequence to be coordinated from a common *Track* control signal. This can be an open-collector (or open-drain) device, such as a power-up reset voltage supervisor IC. See U3 in [Figure 16](#).

To coordinate a power-up sequence, the *Track* control must first be pulled to ground potential. This should be done at or before input power is applied to the modules. The ground signal should be maintained for at least 40 ms after input power has been applied. This brief period gives the modules time to complete their internal soft-start initialization <sup>(4)</sup>, enabling them to produce an output voltage. A low-cost supply voltage supervisor IC, with a built-in time delay, is an ideal component for automatically controlling the *Track* inputs at power up.

[Figure 16](#) shows how the TL7712A supply voltage supervisor IC (U3) can be used to coordinate the sequenced power up of two 12-V input Auto-Track modules. The output of the TL7712A supervisor becomes active above an input voltage of 3.6 V, enabling it to assert a ground signal to the common *Track* control well before the input voltage has reached the module's undervoltage lockout threshold. The ground signal is maintained until approximately 43 ms after the input voltage has risen above U3's voltage threshold, which is 10.95 V. The 43-ms time period is controlled by the capacitor C3. The value of 3.3  $\mu$ F provides sufficient time delay for the modules to complete their internal soft-start initialization. The output voltage of each module remains at zero until the *Track* control voltage is allowed to rise. When U3 removes the ground signal, the *Track* control voltage automatically rises. This causes the output voltage of each module to rise simultaneously with the other modules, until each reaches its respective set-point voltage.

[Figure 17](#) shows the output voltage waveforms from the circuit of [Figure 16](#) after input voltage is applied to the circuit. The waveforms,  $V_{O1}$  and  $V_{O2}$ , represent the output voltages from the two power modules, U1 (3.3 V) and U2 (1.8 V), respectively.  $V_{TRK}$ ,  $V_{O1}$ , and  $V_{O2}$  are shown rising together to produce the desired simultaneous power-up characteristic.

The same circuit also provides a power-down sequence. When the input voltage falls below U3's voltage threshold, the ground signal is re-applied to the common *Track* control. This pulls the *Track* inputs to zero volts, forcing the output of each module to follow, as shown in [Figure 18](#). In order for a simultaneous power-down to occur, the *Track* inputs must be pulled low before the input voltage has fallen below the modules' undervoltage lockout. This is an important constraint. Once the modules recognize that a valid input voltage is no longer present, their outputs can no longer follow the voltage applied at their *Track* input. During a power-down sequence, the fall in the output voltage from the modules is limited by the maximum output capacitance and the

Auto-Track slew rate. If the *Track* pin is pulled low at a slew rate greater than 1 V/ms, the discharge of the output capacitors will induce large currents which could exceed the peak current rating of the module. This will result in a reduction in the maximum allowable output capacitance as listed in the Electrical Characteristics table. When controlling the *Track* pin of the PTH12010W using a voltage supervisor IC, the slew rate is increased, therefore  $C_{Omax}$  is reduced to 3300  $\mu$ F.

**Notes on Use of Auto-Track™**

1. The *Track* pin voltage must be allowed to rise above the module set-point voltage before the module regulates at its adjusted set-point voltage.
2. The Auto-Track function tracks almost any voltage ramp during power up, and is compatible with ramp speeds of up to 1 V/ms.
3. The absolute maximum voltage that may be applied to the *Track* pin is the input voltage  $V_I$ .
4. The module cannot follow a voltage at its *Track* control input until it has completed its soft-start initialization. This takes about 40 ms from the time that a valid voltage has been applied to its input. During this period, it is recommended that the *Track* pin be held at ground potential.
5. The Auto-Track function is disabled by connecting the *Track* pin to the input voltage ( $V_I$ ). When Auto-Track is disabled, the output voltage rises at a quicker and more linear rate after input power has been applied.

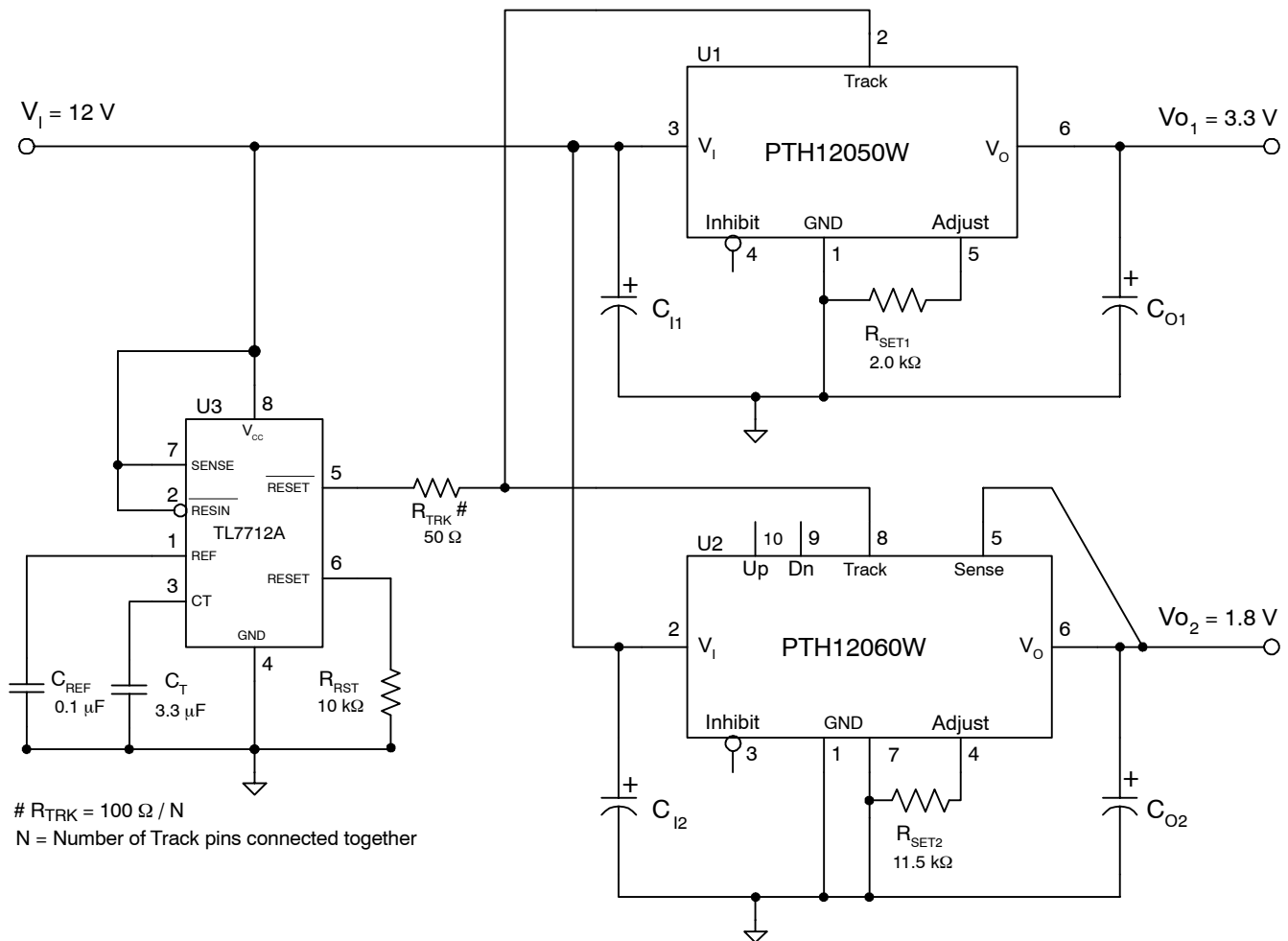

**Figure 16. Sequenced Power Up and Power Down Using Auto-Track**

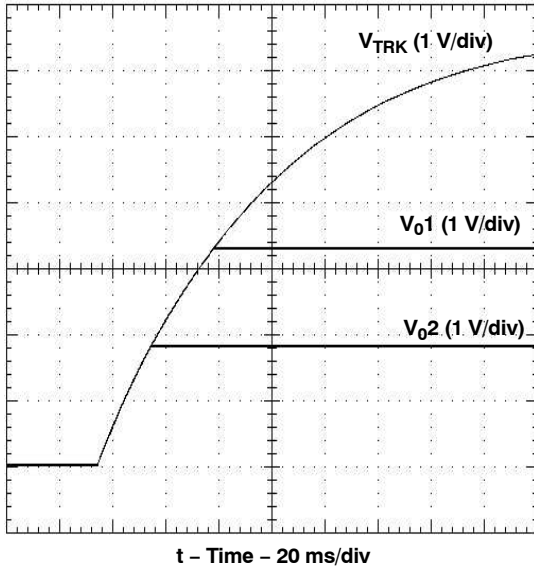

Figure 17. Simultaneous Power Up with Auto-Track Control

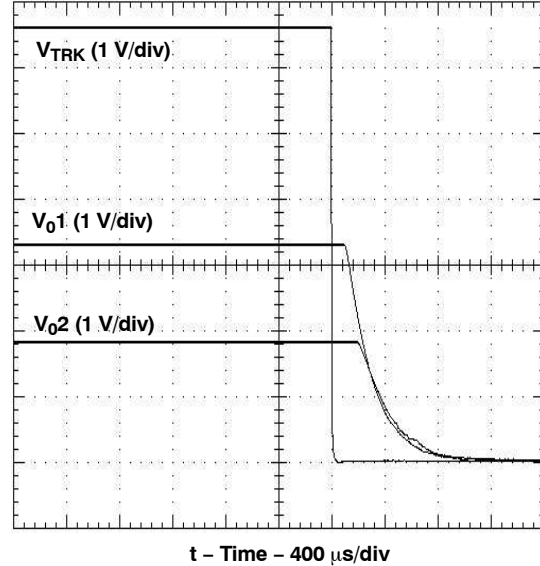

Figure 18. Simultaneous Power Down with Auto-Track Control

## MARGIN UP/DOWN CONTROLS

The PTH12060, PTH12010, PTH12020, and PTH12030 products incorporate *Margin Up* and *Margin Down* control inputs. These controls allow the output voltage to be momentarily adjusted<sup>[1]</sup>, either up or down, by a nominal 5%. This provides a convenient method for dynamically testing the operation of the load circuit over its supply margin or range. It can also be used to verify the function of supply voltage supervisors. The  $\pm 5\%$  change is applied to the adjusted output voltage, as set by the external resistor,  $R_{SET}$  at the  $V_O$  *Adjust* pin.

The 5% adjustment is made by pulling the appropriate margin control input directly to the *GND* terminal<sup>[2]</sup>. A low-leakage open-drain device, such as an N-channel MOSFET or P-channel JFET is recommended for this purpose<sup>[3]</sup>. Adjustments of less than 5% can also be accommodated by adding series resistors to the control inputs. The value of the resistor can be selected from [Table 6](#), calculated using the following formula.

### UP/DOWN ADJUST RESISTANCE CALCULATION

To reduce the margin adjustment to a value less than 5%, series resistors are required (See  $R_D$  and  $R_U$  in [Figure 19](#)). For the same amount of adjustment, the resistor value calculated for  $R_U$  and  $R_D$  are the same. The formula is as follows.

$$R_U \text{ or } R_D = \frac{499}{\Delta\%} - 99.8 \text{ k}\Omega \quad (2)$$

Where  $\Delta\%$  = The desired amount of margin adjust percent.

### NOTES

1. The *Margin Up* and *Margin Down* controls were not intended to be activated simultaneously. If they are their affects on the output voltage may not completely cancel, resulting in the possibility of a slightly higher error in the output voltage set point.
2. The ground reference should be a direct connection to the module *GND* at pin 7 (pin 1 for the PTHxx050). This will produce a more accurate adjustment at the load circuit terminals. The transistors Q1 and Q2 should be located close to the regulator.
3. The *Margin Up* and *Margin Down* control inputs are not compatible with devices that source voltage. This includes TTL logic. These are analog inputs and should only be controlled with a true open-drain device (preferably a discrete MOSFET transistor). The device selected should have low off-state leakage current. Each input sources 8  $\mu\text{A}$  when grounded, and has an open-circuit voltage of 0.8 V.

Table 6. Margin Up/Down Resistor Values

% ADJUST	$R_U / R_D$
5	0 k $\Omega$
4	24.9 k $\Omega$
3	66.5 k $\Omega$
2	150 k $\Omega$
1	397 k $\Omega$

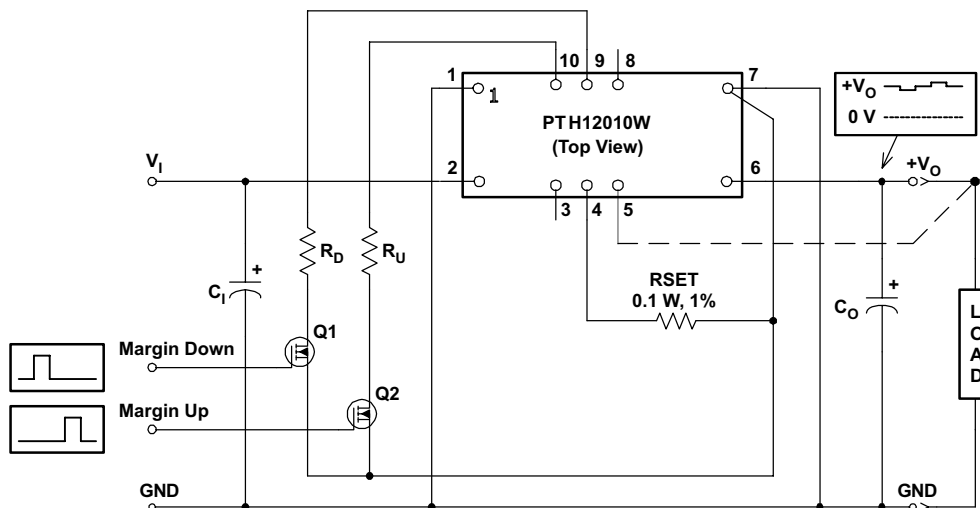

Figure 19. Margin Up/Down Application Schematic

### PREBIAS STARTUP CAPABILITY

The capability to start up into an output prebias condition is now available to all the 12-V input, PTH series of power modules. (Note that this is a feature enhancement for the many of the W-suffix products).<sup>[1]</sup>

A prebias startup condition occurs as a result of an external voltage being present at the output of a power module prior to its output becoming active. This often occurs in complex digital systems when current from another power source is backedfed through a dual-supply logic component, such as an FPGA or ASIC. Another path might be via clamp diodes, sometimes used as part of a dual-supply power-up sequencing arrangement. A prebias can cause problems with power modules that incorporate synchronous rectifiers. This is because under most operating conditions, such modules can sink as well as source output current. The 12-V input PTH modules all incorporate synchronous rectifiers, but does not sink current during startup, or whenever the *Inhibit* pin is held low. Startup includes an initial delay (approx. 8–15 ms), followed by the rise of the output voltage under the control of the module’s internal soft-start mechanism; see Figure 20.

### CONDITIONS FOR PREBIAS HOLDOFF

In order for the module to allow an output prebias voltage to exist (and not sink current), certain conditions must be maintained. The module holds off a prebias voltage when the *Inhibit* pin is held low, and whenever the output is allowed to rise under soft-start control. Power up under soft-start control occurs upon the removal of the ground signal to the *Inhibit* pin (with input voltage applied), or when input power is applied with Auto-Track disabled.<sup>[2]</sup> To further ensure that the regulator doesn’t sink output current, (even with a ground signal applied to its *Inhibit*), the input voltage must always be greater than the applied pre-bias source. This condition must exist throughout the power-up sequence.<sup>[3]</sup>

The soft-start period is complete when the output begins rising above the pre-bias voltage. Once it is complete the module functions as normal, and sinks current if voltage higher than the nominal regulation value is applied to its output.

*Note: If a prebias condition is not present, the soft-start period is complete when the output voltage has risen to either the set-point voltage, or the voltage applied at the module’s Track control pin, whichever is lowest.*

## DEMONSTRATION CIRCUIT

Figure 21 shows the startup waveforms for the demonstration circuit shown in Figure 22. The initial rise in  $V_{O2}$  is the prebias voltage, which is passed from the VCCIO to the VCORE voltage rail through the ASIC. Note that the output current from the PTH12010L module ( $I_{O2}$ ) is negligible until its output voltage rises above the applied prebias.

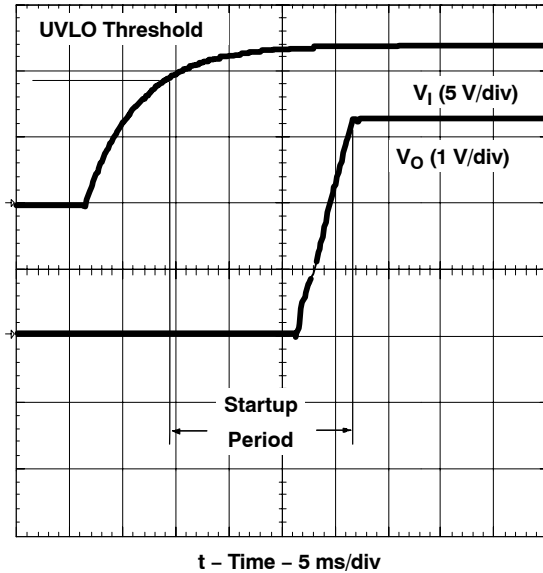

Figure 20. PTH12020W Startup

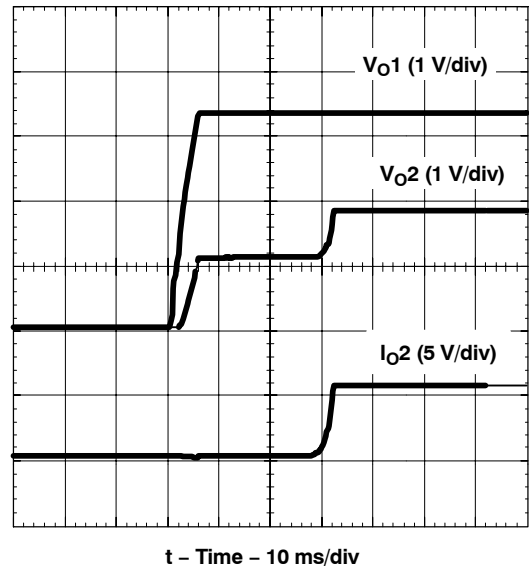

Figure 21. Prebias Startup Waveforms

## NOTES

1. Output prebias holdoff is an inherent feature to all PTH120x0L and PTV120x0W/L modules. It has now been incorporated into all modules (including W-suffix modules with part numbers of the form PTH120x0W), with a production lot date code of 0423 or later.
2. The prebias start-up feature is not compatible with Auto-Track. If the rise in the output is limited by the voltage applied to the *Track* control pin, the output sinks current during the period that the track control voltage is below that of the back-feeding source. For this reason, it is recommended that Auto-Track be disabled when not being used. This is accomplished by connecting the *Track* pin to the input voltage,  $V_I$ . This raises the *Track* pin voltage well above the set-point voltage prior to the module's start up, thereby defeating the Auto-Track feature.
3. To further ensure that the regulator's output does not sink current when power is first applied (even with a ground signal applied to the *Inhibit* control pin), the input voltage must always be greater than the applied pre-bias source. This condition must exist throughout the power-up sequence of the power system.

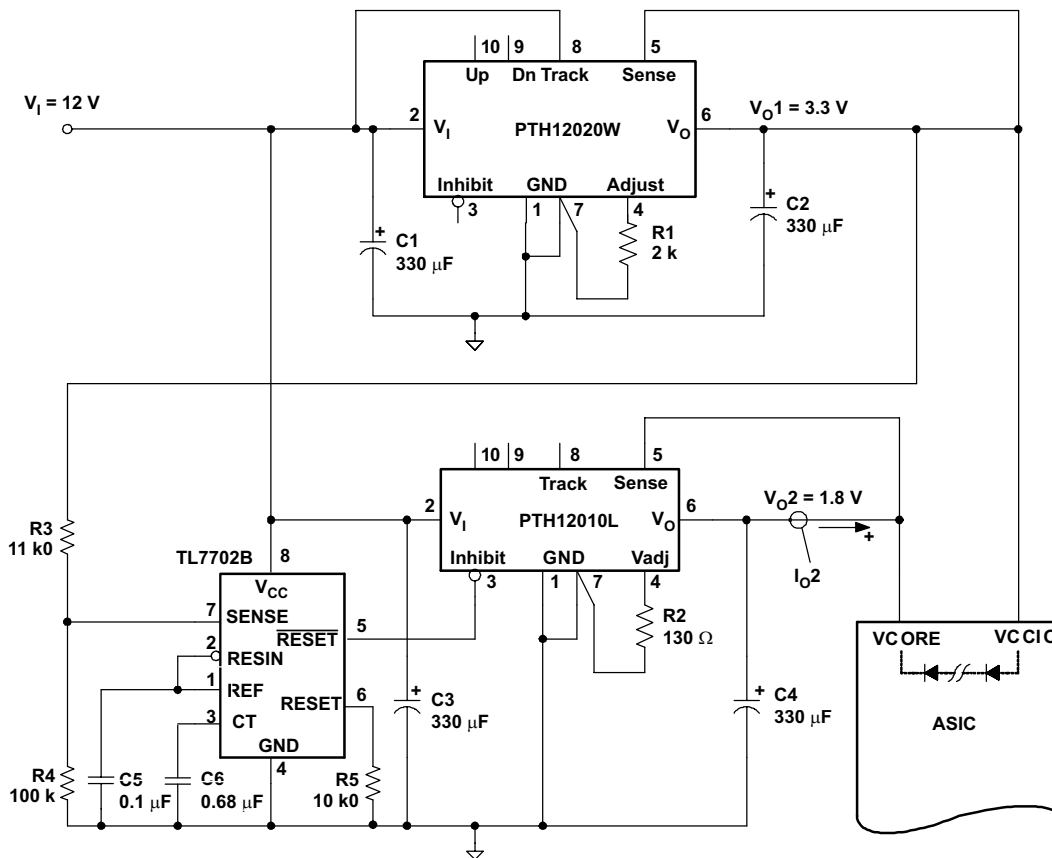

Figure 22. Application Circuit Demonstrating Prebias Startup

### REMOTE SENSE

Products with this feature incorporate an output voltage sense pin,  $V_O$  Sense. A remote sense improves the load regulation performance of the module by allowing it to compensate for any  $IR$  voltage drop between its output and the load. An  $IR$  drop is caused by the high output current flowing through the small amount of pin and trace resistance.

To use this feature simply connect the  $V_O$  Sense pin to the  $V_O$  node, close to the load circuit (see data sheet standard application). If a sense pin is left open-circuit, an internal low-value resistor ( $15\text{-}\Omega$  or less) connected between the pin and the output node, ensures the output remains in regulation.

With the sense pin connected, the difference between the voltage measured directly between the  $V_O$  and  $GND$  pins, and that measured from  $V_O$  Sense to  $GND$ , is the amount of  $IR$  drop being compensated by the regulator. This should be limited to a maximum of  $0.3\text{ V}$ .

*Note: The remote sense feature is not designed to compensate for the forward drop of non-linear or frequency dependent components that may be placed in series with the converter output. Examples include OR-ing diodes, filter inductors, ferrite beads, and fuses. When these components are enclosed by the remote sense connection they are effectively placed inside the regulation control loop, which can adversely affect the stability of the regulator.*

**TAPE AND REEL SPECIFICATIONS**

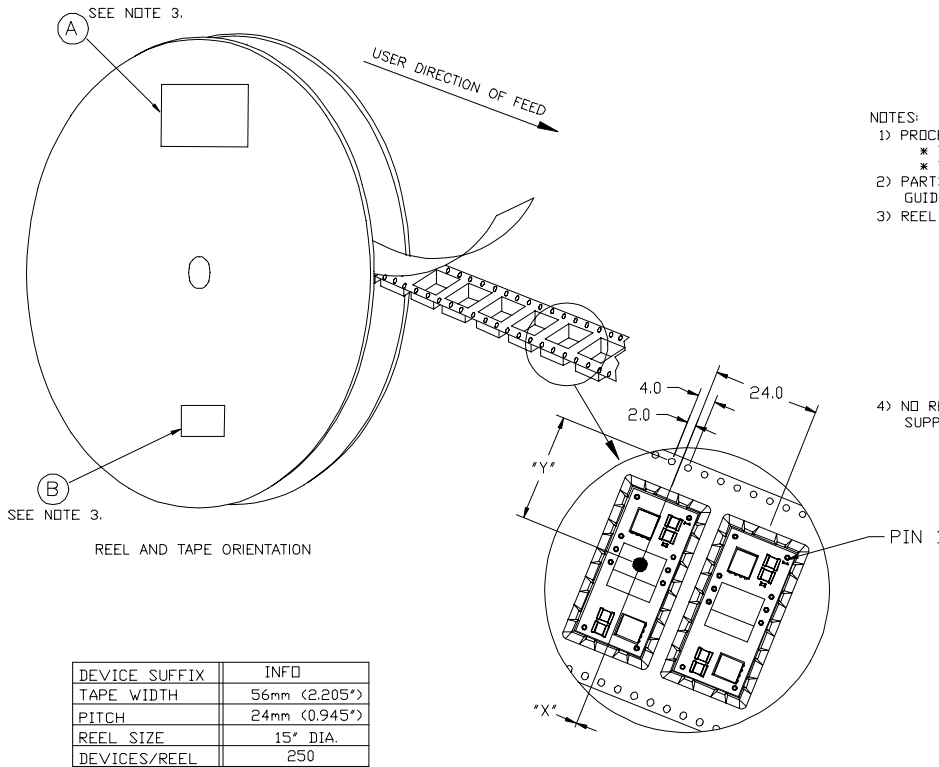

**NOTES:**

- 1) PROCESS IN ACCORDANCE WITH EIA-481-2
  - \* TAPE LEADER DIMENSION 15.30" MIN.
  - \* TAPE TRAILER DIMENSION 6.30" MIN.
- 2) PARTS SHOULD BE PACKAGED IN ACCORDANCE WITH ESD GUIDELINES IN EIA-541.
- 3) REEL LABEL: \*A\*-
  - \* TI PART NUMBER.
  - \* QUANTITY
  - \* DATE CODE
  - \* LOT NUMBER
  - \* MSL DATA
  - \* MADE IN
  - \* ASSY SITE ORIGIN
  - \* COUNTRY OF ORIGIN
  - \* SUPPLIER
- \*B\*- ANTI-STATIC CAUTION LABEL
- 4) NO REQUIREMENT FOR TAPE DIRECTION OF FEED FROM SUPPLIER REEL.

PTXXXXIX	"X"	"Y"
PTH03010/05010	0.0mm	24.3mm
PTH12010	0.0mm	23.8mm

**TRAY SPECIFICATIONS**

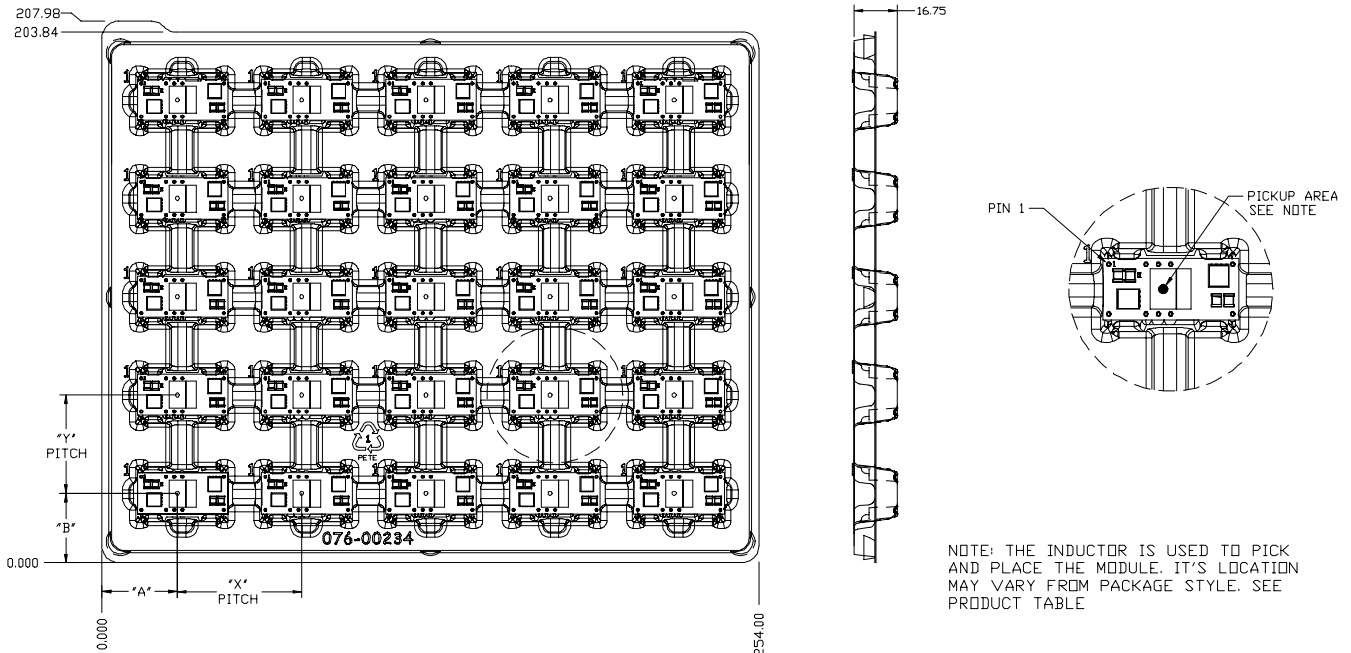

PTXXXXIX	"A"	"B"	"X"	"Y"
PTH03010/05010	28.99	26.64	47.73	37.77
PTH12010	28.48	26.64		

ALL DIMENSIONS ARE IN MILLIMETER.

DEVICES/TRAY	25
--------------	----

**PACKAGING INFORMATION**

Orderable Device	Status <sup>(1)</sup>	Package Type	Package Drawing	Pins	Package Qty	Eco Plan <sup>(2)</sup>	Lead/Ball Finish	MSL Peak Temp <sup>(3)</sup>
PTH12010LAH	ACTIVE	DIP MOD ULE	EUH	10	25	Pb-Free (RoHS)	Call TI	N / A for Pkg Type
PTH12010LAS	ACTIVE	DIP MOD ULE	EUJ	10	25	TBD	Call TI	Level-1-235C-UNLIM
PTH12010LAST	ACTIVE	DIP MOD ULE	EUJ	10	250	TBD	Call TI	Level-1-235C-UNLIM
PTH12010LAZ	ACTIVE	DIP MOD ULE	EUJ	10	25	Pb-Free (RoHS)	Call TI	Level-3-260C-168 HR
PTH12010LAZT	ACTIVE	DIP MOD ULE	EUJ	10	250	Pb-Free (RoHS)	Call TI	Level-3-260C-168 HR
PTH12010WAH	ACTIVE	DIP MOD ULE	EUH	10	25	Pb-Free (RoHS)	Call TI	N / A for Pkg Type
PTH12010WAS	ACTIVE	DIP MOD ULE	EUJ	10	25	TBD	Call TI	Level-1-235C-UNLIM
PTH12010WAST	ACTIVE	DIP MOD ULE	EUJ	10	250	TBD	Call TI	Level-1-235C-UNLIM
PTH12010WAZ	ACTIVE	DIP MOD ULE	EUJ	10	25	Pb-Free (RoHS)	Call TI	Level-3-260C-168 HR
PTH12010WAZT	ACTIVE	DIP MOD ULE	EUJ	10	250	Pb-Free (RoHS)	Call TI	Level-3-260C-168 HR

<sup>(1)</sup> The marketing status values are defined as follows:

**ACTIVE:** Product device recommended for new designs.

**LIFEBUY:** TI has announced that the device will be discontinued, and a lifetime-buy period is in effect.

**NRND:** Not recommended for new designs. Device is in production to support existing customers, but TI does not recommend using this part in a new design.

**PREVIEW:** Device has been announced but is not in production. Samples may or may not be available.

**OBsolete:** TI has discontinued the production of the device.

<sup>(2)</sup> Eco Plan - The planned eco-friendly classification: Pb-Free (RoHS), Pb-Free (RoHS Exempt), or Green (RoHS & no Sb/Br) - please check <http://www.ti.com/productcontent> for the latest availability information and additional product content details.

**TBD:** The Pb-Free/Green conversion plan has not been defined.

**Pb-Free (RoHS):** TI's terms "Lead-Free" or "Pb-Free" mean semiconductor products that are compatible with the current RoHS requirements for all 6 substances, including the requirement that lead not exceed 0.1% by weight in homogeneous materials. Where designed to be soldered at high temperatures, TI Pb-Free products are suitable for use in specified lead-free processes.

**Pb-Free (RoHS Exempt):** This component has a RoHS exemption for either 1) lead-based flip-chip solder bumps used between the die and package, or 2) lead-based die adhesive used between the die and leadframe. The component is otherwise considered Pb-Free (RoHS compatible) as defined above.

**Green (RoHS & no Sb/Br):** TI defines "Green" to mean Pb-Free (RoHS compatible), and free of Bromine (Br) and Antimony (Sb) based flame retardants (Br or Sb do not exceed 0.1% by weight in homogeneous material)

<sup>(3)</sup> MSL, Peak Temp. -- The Moisture Sensitivity Level rating according to the JEDEC industry standard classifications, and peak solder temperature.

**Important Information and Disclaimer:** The information provided on this page represents TI's knowledge and belief as of the date that it is provided. TI bases its knowledge and belief on information provided by third parties, and makes no representation or warranty as to the accuracy of such information. Efforts are underway to better integrate information from third parties. TI has taken and continues to take reasonable steps to provide representative and accurate information but may not have conducted destructive testing or chemical analysis on incoming materials and chemicals. TI and TI suppliers consider certain information to be proprietary, and thus CAS numbers and other limited information may not be available for release.

In no event shall TI's liability arising out of such information exceed the total purchase price of the TI part(s) at issue in this document sold by TI to Customer on an annual basis.

EUH (R-PDSS-T10)

DOUBLE SIDED MODULE

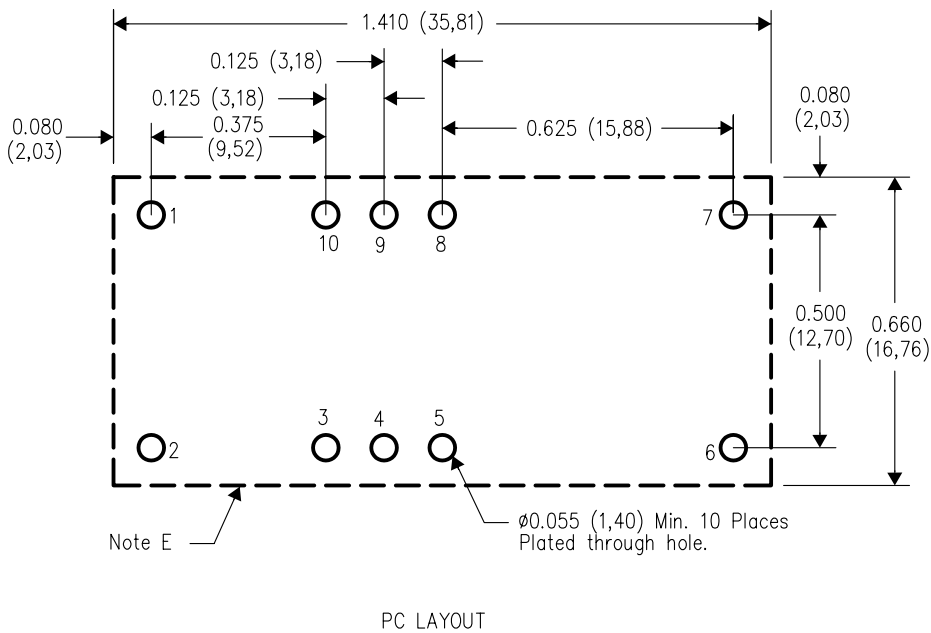
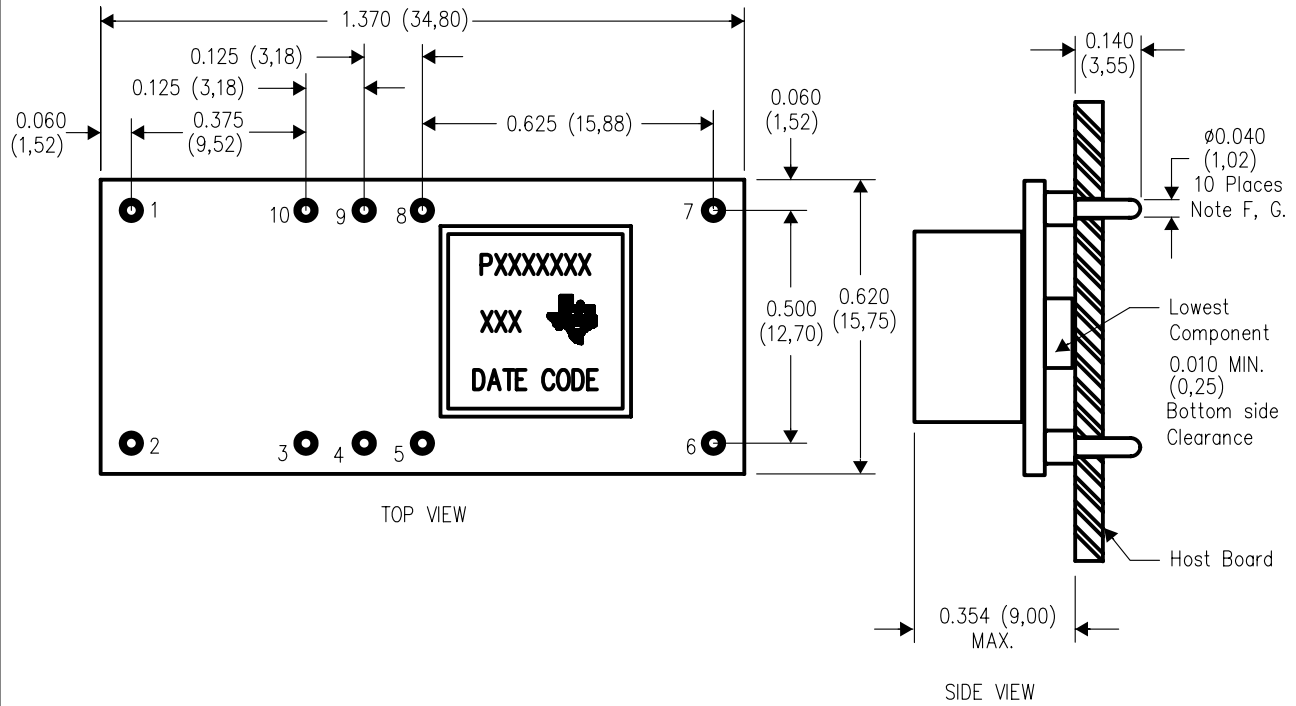

4204984-3/E 12/05

- NOTES:
- A. All linear dimensions are in inches (mm).
  - B. This drawing is subject to change without notice.
  - C. 2 place decimals are  $\pm 0.030$  ( $\pm 0.76$ mm).
  - D. 3 place decimals are  $\pm 0.010$  ( $\pm 0.25$ mm).
  - E. Recommended keep out area for user components.

- F. Pins are 0.040" (1,02) diameter with 0.070" (1,78) diameter standoff shoulder.
- G. All pins: Material - Copper Alloy  
Finish - Tin (100%) over Nickel plate

# EUJ (R-PDSS-B10)

# DOUBLE SIDED MODULE

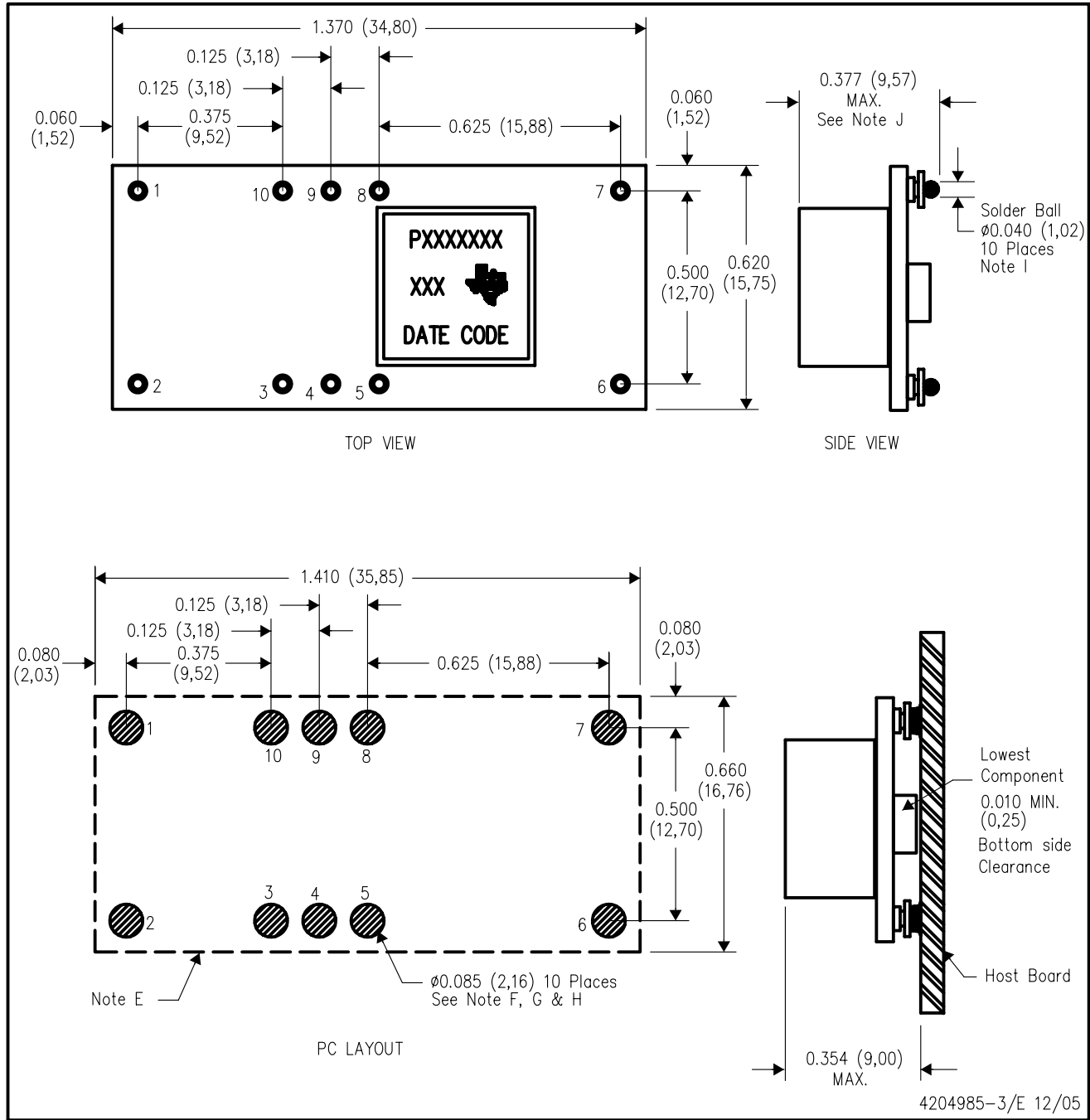

- NOTES:
- A. All linear dimensions are in inches (mm).
  - B. This drawing is subject to change without notice.
  - C. 2 place decimals are  $\pm 0.030$  ( $\pm 0,76$ mm).
  - D. 3 place decimals are  $\pm 0.010$  ( $\pm 0,25$ mm).
  - E. Recommended keep out area for user components.
  - F. Power pin connection should utilize two or more vias to the interior power plane of 0.025 (0,63) I.D. per input, ground and output pin (or the electrical equivalent).
  - G. Paste screen opening: 0.080 (2,03) to 0.085 (2,16).  
Paste screen thickness: 0.006 (0,15).
  - H. Pad type: Solder mask defined.
  - I. All pins: Material – Copper Alloy  
Finish – Tin (100%) over Nickel plate  
Solder Ball – See product data sheet.
  - J. Dimension prior to reflow solder.

## IMPORTANT NOTICE

Texas Instruments Incorporated and its subsidiaries (TI) reserve the right to make corrections, modifications, enhancements, improvements, and other changes to its products and services at any time and to discontinue any product or service without notice. Customers should obtain the latest relevant information before placing orders and should verify that such information is current and complete. All products are sold subject to TI's terms and conditions of sale supplied at the time of order acknowledgment.

TI warrants performance of its hardware products to the specifications applicable at the time of sale in accordance with TI's standard warranty. Testing and other quality control techniques are used to the extent TI deems necessary to support this warranty. Except where mandated by government requirements, testing of all parameters of each product is not necessarily performed.

TI assumes no liability for applications assistance or customer product design. Customers are responsible for their products and applications using TI components. To minimize the risks associated with customer products and applications, customers should provide adequate design and operating safeguards.

TI does not warrant or represent that any license, either express or implied, is granted under any TI patent right, copyright, mask work right, or other TI intellectual property right relating to any combination, machine, or process in which TI products or services are used. Information published by TI regarding third-party products or services does not constitute a license from TI to use such products or services or a warranty or endorsement thereof. Use of such information may require a license from a third party under the patents or other intellectual property of the third party, or a license from TI under the patents or other intellectual property of TI.

Reproduction of information in TI data books or data sheets is permissible only if reproduction is without alteration and is accompanied by all associated warranties, conditions, limitations, and notices. Reproduction of this information with alteration is an unfair and deceptive business practice. TI is not responsible or liable for such altered documentation.

Resale of TI products or services with statements different from or beyond the parameters stated by TI for that product or service voids all express and any implied warranties for the associated TI product or service and is an unfair and deceptive business practice. TI is not responsible or liable for any such statements.

Following are URLs where you can obtain information on other Texas Instruments products and application solutions:

<b>Products</b>		<b>Applications</b>	
Amplifiers	<a href="http://amplifier.ti.com">amplifier.ti.com</a>	Audio	<a href="http://www.ti.com/audio">www.ti.com/audio</a>
Data Converters	<a href="http://dataconverter.ti.com">dataconverter.ti.com</a>	Automotive	<a href="http://www.ti.com/automotive">www.ti.com/automotive</a>
DSP	<a href="http://dsp.ti.com">dsp.ti.com</a>	Broadband	<a href="http://www.ti.com/broadband">www.ti.com/broadband</a>
Interface	<a href="http://interface.ti.com">interface.ti.com</a>	Digital Control	<a href="http://www.ti.com/digitalcontrol">www.ti.com/digitalcontrol</a>
Logic	<a href="http://logic.ti.com">logic.ti.com</a>	Military	<a href="http://www.ti.com/military">www.ti.com/military</a>
Power Mgmt	<a href="http://power.ti.com">power.ti.com</a>	Optical Networking	<a href="http://www.ti.com/opticalnetwork">www.ti.com/opticalnetwork</a>
Microcontrollers	<a href="http://microcontroller.ti.com">microcontroller.ti.com</a>	Security	<a href="http://www.ti.com/security">www.ti.com/security</a>
Low Power Wireless	<a href="http://www.ti.com/lpw">www.ti.com/lpw</a>	Telephony	<a href="http://www.ti.com/telephony">www.ti.com/telephony</a>
		Video & Imaging	<a href="http://www.ti.com/video">www.ti.com/video</a>
		Wireless	<a href="http://www.ti.com/wireless">www.ti.com/wireless</a>

Mailing Address: Texas Instruments  
Post Office Box 655303 Dallas, Texas 75265