

2.25-A, WIDE-INPUT ADJUSTABLE SWITCHING REGULATOR

FEATURES

- Up to 2.25-A Output Current at 85°C
- 4.5-V to 18-V Input Voltage Range
- Wide-Output Voltage Adjust (0.9 V to 5.5 V)
- Efficiencies Up To 93%
- On/Off Inhibit
- Undervoltage Lockout (UVLO)
- Output Overcurrent Protection (Nonlatching, Auto-Reset)
- Overtemperature Protection
- Ambient Temperature Range: –40°C to 85°C

- Surface-Mount Package
- Safety Agency Approvals: UL/CUL 60950, EN60950

APPLICATIONS

- Telecommunications, Instrumentation, and General-Purpose Circuits

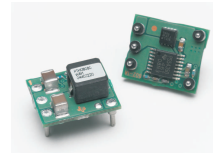

DESCRIPTION

The PTH08080W is a highly integrated, low-cost switching regulator module that delivers up to 2.25 A of output current. The PTH08080W sources output current at a much higher efficiency than a TO-220 linear regulator IC, thereby eliminating the need for a heat sink. Its small size (0.5 × 0.6 in) and flexible operation creates value for a variety of applications.

The input voltage range of the PTH08080W is from 4.5 V to 18 V, allowing operation from either a 5-V or 12-V input bus. Using state-of-the-art switched-mode power-conversion technology, the PTH08080W can step down to voltages as low as 0.9 V from a 5-V input bus, with less than 1 W of power dissipation. The output voltage can be adjusted to any voltage over the range, 0.9 V to 5.5 V, using a single external resistor. Operating features include an undervoltage lockout (UVLO), on/off inhibit, overcurrent protection, and overtemperature protection. Target applications include telecommunications, test and measurement applications, and high-end consumer products. This product is available in both through-hole and surface-mount package options, including tape and reel.

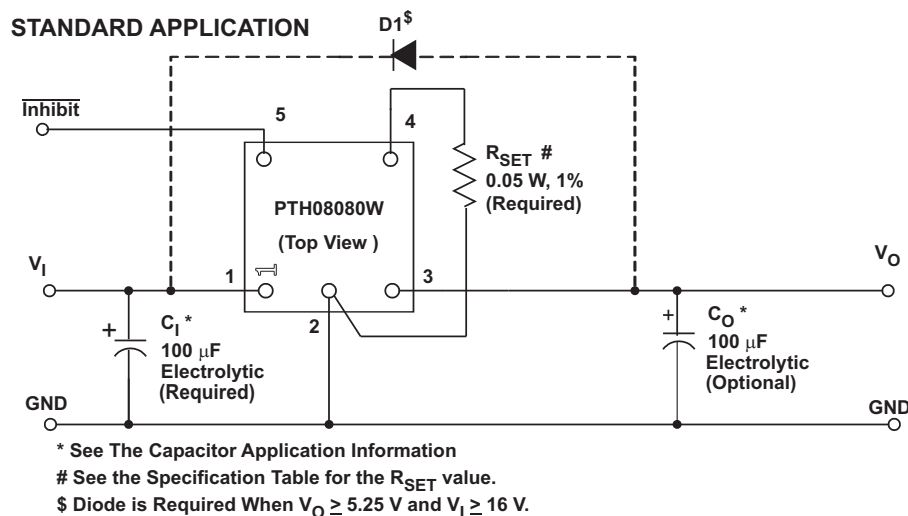

Please be aware that an important notice concerning availability, standard warranty, and use in critical applications of Texas Instruments semiconductor products and disclaimers thereto appears at the end of this data sheet.



These devices have limited built-in ESD protection. The leads should be shorted together or the device placed in conductive foam during storage or handling to prevent electrostatic damage to the MOS gates.

ORDERING INFORMATION

For the most current package and ordering information, see the Package Option Addendum at the end of this datasheet, or see the TI website at www.ti.com.

ABSOLUTE MAXIMUM RATINGS

over operating free-air temperature range unless otherwise noted⁽¹⁾

		PTH08080W	UNIT
T _A	Operating free-air temperature	Over V _{in} range	–40 to 85 °C
	Solder reflow temperature	Surface temperature of module body or pins	235 °C
T _{stg}	Storage temperature		–40 to 125 °C

(1) Stresses beyond those listed under absolute maximum ratings may cause permanent damage to the device. These are stress ratings only, and functional operation of the device at these or any other conditions beyond those indicated under recommended operating conditions is not implied. Exposure to absolute-maximum-rated conditions for extended periods may affect device reliability.

RECOMMENDED OPERATING CONDITIONS

		MIN	MAX	UNIT
V _I	Input voltage	4.5	18	V
T _A	Operating free-air temperature	–40	85	°C

PACKAGE SPECIFICATIONS

PTH08080W (Suffix AH and AS)		
Weight		1.5 grams
Flammability	Meets UL 94 V-O	
Mechanical shock	Per Mil-STD-883D, Method 2002.3, 1 ms, 1/2 sine, mounted	500 G ⁽¹⁾
Mechanical vibration	Mil-STD-883D, Method 2007.2, 20-2000 Hz	20 G ⁽¹⁾

(1) Qualification limit.

ELECTRICAL CHARACTERISTICS

at 25°C free-air temperature, $V_I = 12\text{ V}$, $V_O = 3.3\text{ V}$, $I_O = I_{O,max}$, $C_I = 100\text{ }\mu\text{F}$, $C_O = 100\text{ }\mu\text{F}$ (unless otherwise noted)

PARAMETER		TEST CONDITIONS	MIN	TYP	MAX	UNIT
I_O	Output current	$T_A = 85^\circ\text{C}$, natural convection airflow	0		2.25	A
P_O	Output power	$T_A = 85^\circ\text{C}$, natural convection airflow			10	W
V_O	Set-point voltage tolerance	$T_A = 25^\circ\text{C}$			± 2 ⁽¹⁾	%
	Temperature variation	$-40 \leq T_A \leq +85^\circ\text{C}$		± 0.5		% V_O
	Line regulation	Over V_I range		± 7		mV
	Load regulation	Over I_O range		± 0.13		% V_O
	Total output voltage variation	Includes set-point, line, load, $-40 \leq T_A \leq +85^\circ\text{C}$			3 ⁽¹⁾	% V_O
V_{ADJ}	Output Voltage Adjust Range	Over I_O range	0.9		5.5	V
V_I	Input Voltage Range	Over V_O range				
		$0.9\text{ V} \leq V_O \leq 1.8\text{ V}$	4.5		$V_O \times 10$ ⁽²⁾	V
		$1.8\text{ V} < V_O \leq 3.4\text{ V}$	4.5		18	
		$3.4\text{ V} < V_O \leq 5.5\text{ V}$	$V_O + 1.1$ ⁽²⁾		18 ⁽²⁾	
η	Efficiency	$T_A = 25^\circ\text{C}$, $I_O = 2\text{ A}$	$R_{SET} = 348\text{ }\Omega$, $V_O = 5\text{ V}$		93.5%	
			$R_{SET} = 1.87\text{ k}\Omega$, $V_O = 3.3\text{ V}$		92%	
			$R_{SET} = 3.74\text{ k}\Omega$, $V_O = 2.5\text{ V}$		91%	
			$R_{SET} = 6.19\text{ k}\Omega$, $V_O = 2\text{ V}$		90%	
			$R_{SET} = 8.06\text{ k}\Omega$, $V_O = 1.8\text{ V}$		89%	
			$R_{SET} = 13\text{ k}\Omega$, $V_O = 1.5\text{ V}$		87.5%	
			$R_{SET} = 27.4\text{ k}\Omega$, $V_O = 1.2\text{ V}$		86.5%	
	Output voltage ripple	20 MHz bandwidth		30		mV _{PP}
I_O (trip)	Overcurrent threshold	Reset, followed by autorecovery		3.5		A
	Transient response	$C_O = 100\text{ }\mu\text{F}$, 1 A/ μs load step from 50% to 100% $I_{O,max}$	Recovery time		50	μs
			V_O over/undershoot		70	mV
UVLO	Undervoltage lockout	$V_I = \text{increasing}$		4.35	4.5	V
		$V_I = \text{decreasing}$	3.6	4		
	Inhibit control (pin 5)	Input high voltage (V_{IH})			Open ⁽³⁾	V
		Input low voltage (V_{IL})	-0.2		0.5	
		Input low current (I_{IL})		5		μA
I_I (stby)	Input standby current	Pins 5 and 2 connected		1		mA
f_S	Switching frequency	Over V_I and I_O ranges		300		kHz
	External input capacitance	Electrolytic type (C_I)	100 ⁽⁴⁾			μF
	External output capacitance	Ceramic type (C_O)			220	μF
		Nonceramic type (C_O)		100 ⁽⁵⁾	330 ⁽⁶⁾	
		Equivalent series resistance (nonceramic)	10 ⁽⁷⁾			m Ω
MTBF	Calculated reliability	Per Telcordia SR-332, 50% stress, $T_A = 40^\circ\text{C}$, ground benign	48			10^6 Hr

- (1) The set-point voltage tolerance is affected by the tolerance and stability of R_{SET} . The stated limit is unconditionally met if R_{SET} has a tolerance of 1% with 100 ppm/ $^\circ\text{C}$ or better temperature stability.
- (2) The minimum input voltage is 4.5 V or $(V_O + 1.1)\text{ V}$, whichever is greater. The maximum input voltage is 18 V or $V_O \times 10$, whichever is less.
- (3) This control pin has an internal pull-up to 3 V (TYP). Do not place an internal pull-up on this pin. If it is left open-circuit, the module operates when input power is applied. A small low-leakage ($< 100\text{ nA}$) MOSFET is recommended for control. See the application information for further guidance.
- (4) An external 100- μF electrolytic capacitor is required across the input (V_I and GND) for proper operation. Locate the capacitor close to the module.
- (5) An external 100- μF electrolytic capacitor is optional across the output (V_O and GND). Locate the capacitor close to the module. Additional capacitance close to the load improves the response of the regulator to load transients.
- (6) This is the calculated maximum capacitance. The minimum ESR limitation often results in a lower value. See the capacitor application information for further guidance.
- (7) This is the typical ESR for all the electrolytic (nonceramic) capacitance. Use 14 m Ω as the minimum when calculating the total equivalent series resistance (ESR) using the maximum ESR values specified by the capacitor manufacturer.

PIN ASSIGNMENT

TERMINAL FUNCTIONS

TERMINAL		I/O	DESCRIPTION
NAME	NO.		
V_I	1	I	The positive input voltage power node to the module, which is referenced to common GND.
GND	2		This is the common ground connection for the V_I and V_O power connections. It is also the 0-Vdc reference for the <i>Inhibit</i> and V_O <i>Adjust</i> control inputs.
V_O	3	O	The regulated positive power output with respect to the GND node.
V_O Adjust	4	I	A 1% resistor must be connected between this pin and GND (pin 1) to set the output voltage of the module higher than 0.9 V. If left open-circuit, the output voltage defaults to this value. The temperature stability of the resistor should be 100 ppm/°C (or better). The set-point range is from 0.9 V to 5.5 V. The electrical specification table gives the standard resistor value for a number of common output voltages. See the application information for further guidance.
$\overline{\text{Inhibit}}$	5	I	The Inhibit pin is an open-collector/drain-negative logic input that is referenced to GND. Applying a low-level ground signal to this input disables the module's output. When the Inhibit control is active, the input current drawn by the regulator is significantly reduced. If the Inhibit pin is left open-circuit, the module produces an output voltage whenever a valid input source is applied. Do not place an external pull-up on this pin.

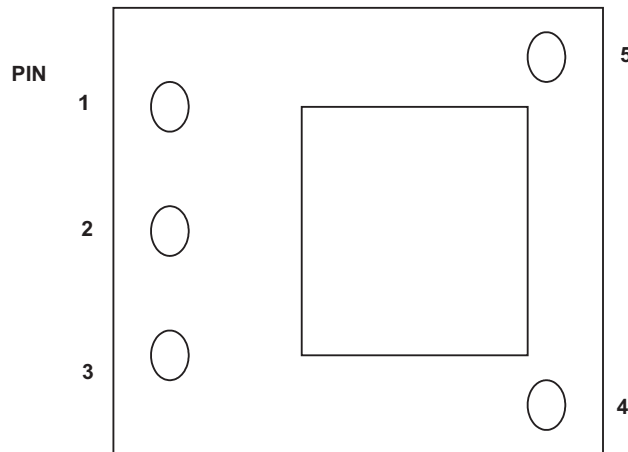

Figure 1. Terminal Location

TYPICAL CHARACTERISTICS (5-V INPUT)⁽¹⁾⁽²⁾

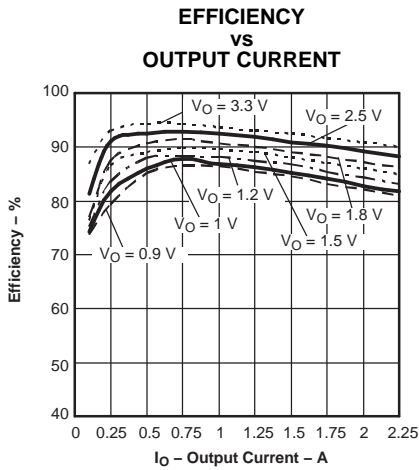

Figure 2.

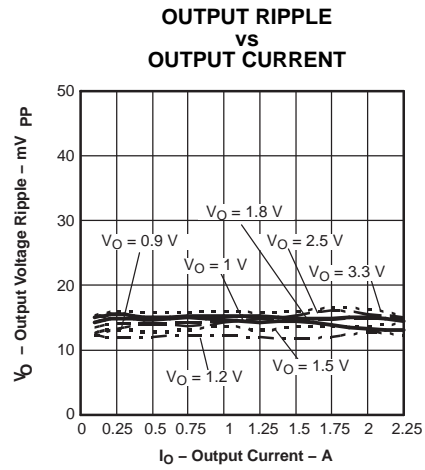

Figure 3.

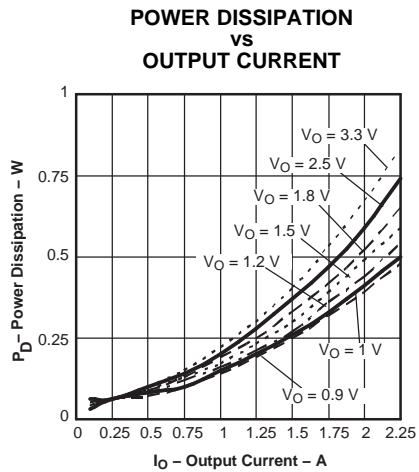

Figure 4.

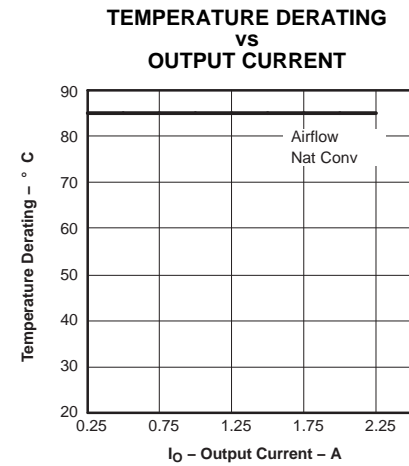

Figure 5.

- (1) The electrical characteristic data has been developed from actual products tested at 25°C. This data is considered typical for the converter. Applies to [Figure 2](#), [Figure 3](#), and [Figure 4](#).
- (2) The temperature derating curves represent the conditions at which internal components are at or below the manufacturer's maximum operating temperatures. Derating limits apply to modules soldered directly to a 100-mm x 100-mm, double-sided PCB with 2-oz. copper. Applies to [Figure 5](#).

TYPICAL CHARACTERISTICS (12-V INPUT)⁽¹⁾⁽²⁾

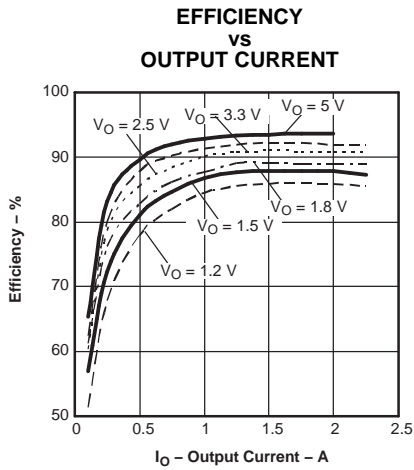

Figure 6.

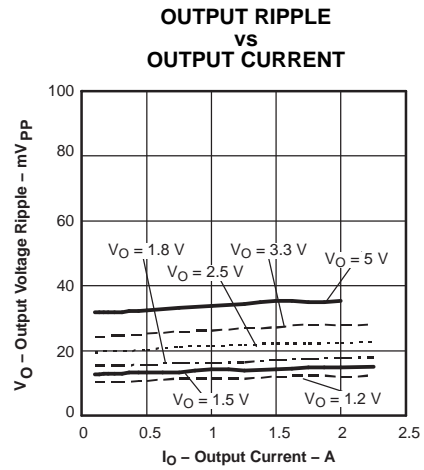

Figure 7.

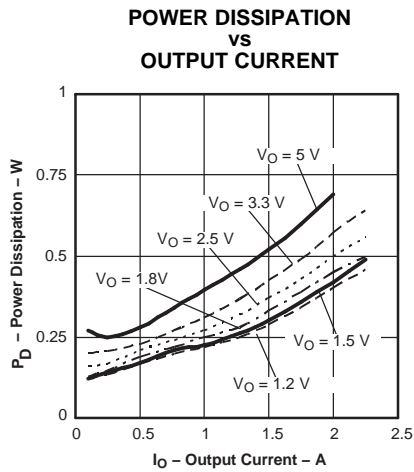

Figure 8.

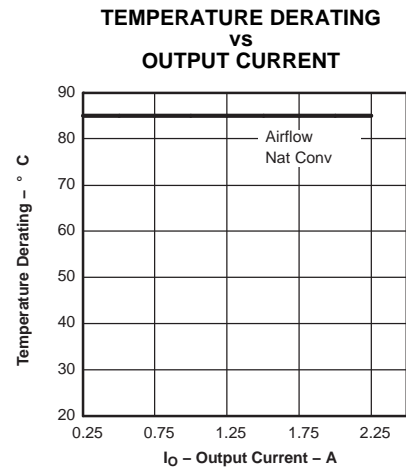

Figure 9.

- (1) The electrical characteristic data has been developed from actual products tested at 25°C. This data is considered typical for the converter. Applies to [Figure 6](#), [Figure 7](#), and [Figure 8](#).
- (2) The temperature derating curves represent the conditions at which internal components are at or below the manufacturer's maximum operating temperatures. Derating limits apply to modules soldered directly to a 100-mm x 100-mm, double-sided PCB with 2-oz. copper. Applies to [Figure 9](#).

APPLICATION INFORMATION

Adjusting the Output Voltage of the PTH08080W Wide-Output Adjust Power Modules

The V_O Adjust control (pin 4) sets the output voltage of the PTH08080W product. The adjustment range is from 0.9 V to 5.5 V. The adjustment method requires the addition of a single external resistor, R_{SET} , that must be connected directly between the V_O Adjust and GND (pin 2). Table 1 gives the standard external resistor for a number of common bus voltages, along with the actual voltage the resistance produces.

For other output voltages, the value of the required resistor can either be calculated using the following formula, or simply selected from the range of values given in Table 2. Figure 10 shows the placement of the required resistor.

$$R_{SET} = 10 \text{ k}\Omega \times \frac{0.891 \text{ V}}{V_{out} - 0.9 \text{ V}} - 1.82 \text{ k}\Omega$$

Table 1. Standard Values of R_{SET} for Common Output Voltages

V_O (Required)	R_{set} (Standard Value)	V_O (Actual)
5 V ⁽¹⁾	348 Ω	5.010 V
3.3 V	1.87 k Ω	3.315 V
2.5 V	3.74 k Ω	2.503 V
2 V	6.19 k Ω	2.012 V
1.8 V	8.06 k Ω	1.802 V
1.5 V ⁽²⁾	13.0 k Ω	1.501 V
1.2 V ⁽²⁾	27.4 k Ω	1.205 V
1 V ⁽²⁾	86.6 k Ω	1.001 V
0.9 V ⁽²⁾	Open	0.9 V

- (1) The minimum input voltage is 4.5 V or ($V_O + 1.1$) V, whichever is greater.
 (2) The maximum input voltage is 18 V or ($V_O \times 10$) V, whichever is lesser.

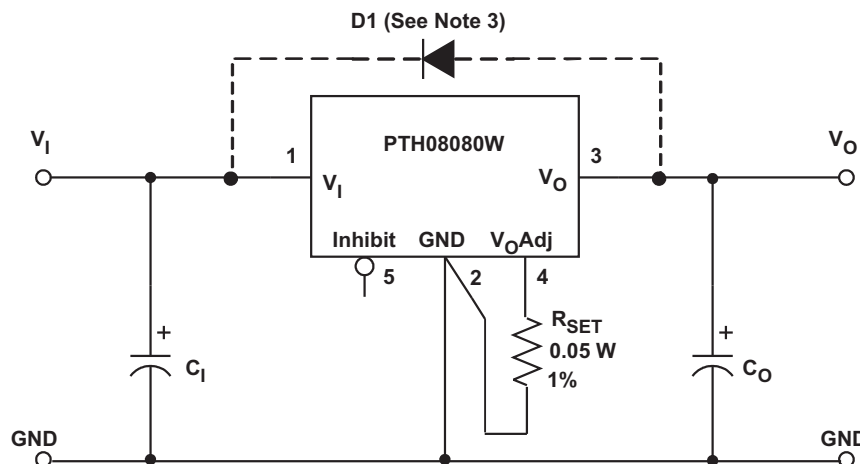

- (1) A 0.05-W rated resistor may be used. The tolerance should be 1%, with a temperature stability of 100 ppm/ $^{\circ}$ C (or better). Place the resistor as close to the regulator as possible. Connect the resistor directly between pins 4 and 2 using dedicated PCB traces.
 (2) Never connect capacitors from V_O Adjust to either GND or V_O . Any capacitance added to the V_O Adjust pin affects the stability of the regulator.
 (3) The protection diode, D1, is required whenever the output voltage setpoint is adjusted to 5.25 V (or higher) and V_I is 16 V or greater.

Figure 10. V_O Adjust Resistor Placement

Table 2. Calculated Set-Point Resistor Values

V_a Required	R_{set}	V_a Required	R_{set}	V_a Required	R_{set}
0.900	Open	1.800	8.08 k Ω	3.700	1.36 k Ω
0.925	355 k Ω	1.850	7.56 k Ω	3.750	1.32 k Ω
0.950	176 k Ω	1.900	7.09 k Ω	3.800	1.25 k Ω
0.975	117 k Ω	1.950	6.67 k Ω	3.850	1.20 k Ω
1.000	87.2 k Ω	2.000	6.28 k Ω	3.900	1.15 k Ω
1.025	69.5 k Ω	2.050	5.92 k Ω	3.950	1.10 k Ω
1.050	57.6 k Ω	2.100	5.61 k Ω	4.000	1.05 k Ω
1.075	49.1 k Ω	2.150	5.31 k Ω	4.050	1.01 k Ω
1.100	42.7 k Ω	2.200	5.03 k Ω	4.100	964 Ω
1.125	37.8 k Ω	2.250	4.78 k Ω	4.150	922 Ω
1.150	33.8 k Ω	2.300	4.54 k Ω	4.200	880 Ω
1.175	30.6 k Ω	2.350	4.33 k Ω	4.250	840 Ω
1.200	27.9 k Ω	2.400	4.12 k Ω	4.300	801 Ω
1.225	25.6 k Ω	2.450	3.93 k Ω	4.350	763 Ω
1.250	23.6 k Ω	2.500	3.75 k Ω	4.400	726 Ω
1.275	21.9 k Ω	2.550	3.58 k Ω	4.450	690 Ω
1.300	20.5 k Ω	2.600	3.42 k Ω	4.500	655 Ω
1.325	19.1 k Ω	2.650	3.27 k Ω	4.550	621 Ω
1.350	17.9 k Ω	2.700	3.13 k Ω	4.600	588 Ω
1.375	16.9 k Ω	2.750	2.99 k Ω	4.650	556 Ω
1.400	14.6 k Ω	2.800	2.87 k Ω	4.700	525 Ω
1.425	13.7 k Ω	2.850	2.75 k Ω	4.750	494 Ω
1.450	13.0 k Ω	2.900	2.64 k Ω	4.800	465 Ω
1.475	13.7 k Ω	2.950	2.53 k Ω	4.850	436 Ω
1.500	13.0 k Ω	3.000	2.42 k Ω	4.900	408 Ω
1.525	12.4 k Ω	3.050	2.32 k Ω	4.950	380 Ω
1.550	11.9 k Ω	3.100	2.23 k Ω	5.000	353 Ω
1.575	11.4 k Ω	3.150	2.14 k Ω	5.050	327 Ω
1.600	10.9 k Ω	3.200	2.05 k Ω	5.100	301 Ω
1.625	10.5 k Ω	3.250	1.97 k Ω	5.150	276 Ω
1.650	10.0 k Ω	3.300	1.89 k Ω	5.200	252 Ω
1.675	9.68 k Ω	3.350	1.82 k Ω	5.250	228 Ω
1.700	9.32 k Ω	3.400	1.74 k Ω	5.300	205 Ω
1.725	8.98 k Ω	3.450	1.67 k Ω	5.350	182 Ω
1.750	8.66 k Ω	3.500	1.61 k Ω	5.400	160 Ω
1.775	8.36 k Ω	3.550	1.54 k Ω	5.450	138 Ω
1.800	8.08 k Ω	3.600	1.48 k Ω	5.500	117 Ω
1.825	7.81 k Ω	3.650	1.42 k Ω		

CAPACITOR RECOMMENDATIONS FOR THE PTH08080W WIDE-OUTPUT ADJUST POWER MODULES

Input Capacitor

The minimum recommended input capacitor is 100 μF of capacitance. When $V_O > 3.4\text{ V}$, the 100- μF electrolytic capacitance must be rated for 650-mArms ripple current. For $V_O < 3.4\text{ V}$, the ripple current rating must be at least 500 mArms. The ripple current rating of electrolytic capacitors is a major consideration when they are used at the input.

When specifying regular tantalum capacitors for use at the input, a minimum voltage rating of $2 \times$ (maximum dc voltage + ac ripple) is highly recommended. This is standard practice to ensure reliability. Polymer-tantalum capacitors are not affected by this requirement.

For improved ripple reduction on the input bus, ceramic capacitors can also be added to complement the required electrolytic capacitance.

Output Capacitors (Optional)

No output capacitance is required for normal operation. However, applications with load transients (sudden changes in load current) can benefit by adding external output capacitance. A 100- μF electrolytic or ceramic capacitor can be used to improve transient response. Adding a 100- μF nonceramic capacitor allows the module to meet its transient response specification. A high-quality computer-grade electrolytic capacitor should be adequate.

Electrolytic capacitors should be located close to the load circuit. These capacitors provide decoupling over the frequency range, 2 kHz to 150 kHz. Aluminum electrolytic capacitors are suitable for ambient temperatures above 0°C . For operation below 0°C , tantalum or Os-Con-type capacitors are recommended. When using one or more nonceramic capacitors, the calculated equivalent ESR should be no lower than 10 m Ω (14 m Ω using the manufacturer's maximum ESR for a single capacitor). A list of preferred low-ESR-type capacitors are identified in [Table 3](#), the recommended capacitor table.

Ceramic Capacitors

Above 150 kHz, the performance of aluminum electrolytic capacitors becomes less effective. To further improve the reflected input ripple current, or the output transient response, multilayer ceramic capacitors must be added. Ceramic capacitors have low ESR and their resonant frequency is higher than the bandwidth of the regulator. When placed at the output their combined ESR is not critical as long as the total value of ceramic capacitance does not exceed 200 μF . Also, to prevent the formation of local resonances, do not exceed the maximum number of capacitors specified in the capacitor table.

Tantalum Capacitors

Additional tantalum-type capacitors can be used at both the input and output, and are recommended for applications where the ambient operating temperature can be less than 0°C . The AVX TPS, Sprague 593D/594/595, and Kemet T495/T510/T520 capacitors series are suggested over many other tantalum types due to their rated surge, power dissipation, and ripple current capability. As a caution, many general-purpose tantalum capacitors have considerably higher ESR, reduced power dissipation, and lower ripple current capability. These capacitors are also less reliable as they have lower power dissipation and surge current ratings. Tantalum capacitors that do not have a stated ESR or surge current rating are not recommended for power applications. When specifying Os-Con and polymer tantalum capacitors for the output, the minimum ESR limit is encountered well before the maximum capacitance value is reached.

Capacitor Table

The capacitor table, [Table 3](#), identifies the characteristics of capacitors from a number of vendors with acceptable ESR and ripple current (rms) ratings. The recommended number of capacitors required at both the input and output buses is identified for each capacitor type. This is not an extensive capacitor list. Capacitors from other vendors are available with comparable specifications. Those listed are for guidance. The rms rating and ESR (at 100 kHz) are critical parameters necessary to ensure both optimum regulator performance and long capacitor life.

Designing for Load Transients

The transient response of the dc/dc converter has been characterized using a load transient with a di/dt of 1 A/μs. The typical voltage deviation for this load transient is given in the data-sheet specification table using the optional value of output capacitance. As the di/dt of a transient is increased, the response of a converter's regulation circuit ultimately depends on its output capacitor decoupling network. This is an inherent limitation with any dc/dc converter once the speed of the transient exceeds its bandwidth capability. If the target application specifies a higher di/dt or lower voltage deviation, the requirement can only be met with additional output capacitor decoupling. In these cases, special attention must be paid to the type, value, and ESR of the capacitors selected.

If the transient performance requirements exceed those specified in the data sheet, the selection of output capacitors becomes more important. Review the minimum ESR in the characteristic data sheet for details on the capacitance maximum.

Table 3. Recommended Input/Output Capacitors

CAPACITOR VENDOR/ COMPONENT SERIES	CAPACITOR CHARACTERISTICS					QUANTITY		VENDOR NUMBER
	WORKING VOLTAGE (V)	VALUE (μF)	EQUIVALENT SERIES RESISTANCE (ESR) (Ω)	85°C MAXIMUM RIPPLE CURRENT (I _{rms}) (mA)	PHYSICAL SIZE (mm)	INPUT BUS ⁽¹⁾	OUTPUT BUS (Optional)	
Panasonic WA (SMT)	20	150	0.026	3700	10 × 10,2	1	≤ 2	EEFWA1D151P
FC (SMT)	25	220	0.150	670	10 × 10,2	1	1	EEVFC1E221P
Panasonic SL	6.3	47	0.018	2500	7,3 × 4,3	N/R ⁽¹⁾	≤ 3	EEFCD0J470R
SP-cap(SMT)	6.3	120	0.007	3500	7,3 × 4,3	N/R ⁽¹⁾	≤ 1	EEFSD0J121R
United Chemi-con PXA (SMT)	16	150	0.026	3400	10 × 7,7	1	≤ 2	PXA16VC151MJ80TP V _I < 14 V
PS	25	100	0.020	4300	10 × 12,5	1	≤ 2	25PS100MJ12
LXZ	35	220	0.180	760	10 × 12,5	1	1	LXZ35VB221M10X12LL
MVZ (SMT)	25	470	0.090	670	10 × 10	1	1	MVZ25VC471MJ10TP
Nichicon UWG (SMT)	35	100	0.150	670	10 × 10	1	1	UWG1V101MNR1GS
F559(Tantalum)	10	100	0.055	2000	7,7 × 4,3	N/R ⁽¹⁾	≤ 3	F551A107MN
HD	25	220	0.072	760	8 × 11,5	1	1	UHD1E221MPR
Sanyo Os-con\ POS-Cap SVP (SMT)	10	68	0.025	2400	7,3 × 4,3	N/R ⁽¹⁾	≤ 2	10TPE68M
SP	20	150	0.020	4320	10 × 12,7	1	≤ 1	20SVP150M
SP	20	120	0.024	3110	8 × 10,5	1	≤ 2	20SP120M
AVX Tantalum TPS (SMD)	35	47	0.100	1430	7,3 L × 4,3 W × 4,1 H	2	≤ 4	TPSV476M035R0100
	25	47	0.100	1150		2	≤ 4	TPSE476M025R0100 V _I < 13 V
Kemet T520 (SMD)	10	100	0.025	> 2000	7,3 L × 5,7 W × 4 H	N/R ⁽¹⁾	≤ 1	T520V107M010ASE025
AO-CAP	6.3	100	0.018	> 2900		N/R ⁽¹⁾	≤ 1	A700V107M006AT
Vishay/Sprague 594D/SVP(SMD)	35	47	0.280	> 1000	7,3 L × 6 W × 4,1 H 8 × 12	2	≤ 5	595D476X0035R2T
	20	100	0.025	3200		1	≤ 2	94SVP107X0020E12
94SS	20	150	0.030	3200	10 × 10,5	1	≤ 2	94SS157X0020FBP
Murata Ceramic X5R	16	47	0.002	> 1400	3225	1 ⁽²⁾	≤ 3	GRM32ER61C476M V _I < 14 V
TDK ceramic X5R	6.3	47	0.002	> 1400	3225	N/R ⁽¹⁾	≤ 3	C3225X5R0J476MT V _O < 5.5 V
Kemet Ceramic X5R	6.3	47	0.002	> 1400	3225	N/R ⁽¹⁾	≤ 3	C1210C476K9PAC V _O < 5.5 V
TDK Ceramic X7R	25	10	0.002	> 1400	3225	1 ⁽²⁾	≤ 4	C3225X7R1E106K
Murata Ceramic X5R	25	10	0.002	> 1400		1 ⁽²⁾	≤ 4	GRM32DR61E106KA12
Kemet	16	10	0.002	> 1400		1 ⁽²⁾	≤ 4	C1210C106M4PAC V _I < 14 V
TDK Ceramic X7R	25	2.2	0.002	> 1400	3225	1	1	C3225X7R1E225KT/MT
Murata Ceramic X7R	25	2.2	0.002	> 1400		1	1	GRM32RR71J225KC01L
Kemet	25	2.2	0.002	> 1400		1	1	C1210C225K3RAC

(1) The voltage rating of the input capacitor must be selected for the desired operating input voltage range of the regulator. To operate the regulator at a higher input voltage, select a capacitor with a higher voltage rating.

(2) Ceramic capacitors can be used to complement electrolytic types at the input bus by reducing high-frequency ripple current.

Power-Up Characteristics

When configured per the standard application, the PTH08080 power module produces a regulated output voltage following the application of a valid input source voltage. During power up, internal soft-start circuitry slows the rate that the output voltage rises, thereby limiting the amount of in-rush current that can be drawn from the input source. Figure 11 shows the power-up waveforms for a PTH08080W, operating from a 12-V input and with the output voltage adjusted to 1.8 V. The waveforms were measured with a 2-A resistive load.

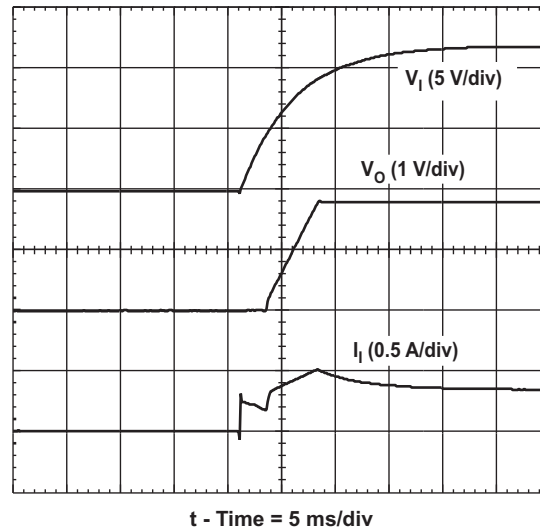

Figure 11. Power-Up Waveforms

Current Limit Protection

The PTH08080 modules protect against load faults with an output overcurrent trip. Under a load fault condition, the output current cannot exceed the current limit value. Attempting to draw current that exceeds the current limit value causes the output voltage to enter into a *hiccup* mode of operation, whereby the module continues in a cycle of successive shutdown and power up until the load fault is removed. On removal of the fault, the output voltage promptly recovers.

Thermal Shutdown

Thermal shutdown protects the module internal circuitry against excessively high temperatures. A rise in temperature may be the result of a drop in airflow, a high ambient temperature, or a higher than normal output current. If the junction temperature of the internal components exceeds 165°C, the module shuts down. This reduces the output voltage to zero. The module starts up automatically, by initiating a soft-start power up when the sensed temperature decreases 10°C below the thermal shutdown trip-point.

Output On/Off Inhibit

For applications requiring output voltage on/off control, the PTH08080 power module incorporates an output on/off Inhibit control (pin 5). The inhibit feature can be used wherever there is a requirement for the output voltage from the regulator to be turned off.

The power module functions normally when the Inhibit pin is left open-circuit, providing a regulated output whenever a valid source voltage is connected to V_I with respect to GND.

Figure 12 shows the typical application of the inhibit function. Note the discrete transistor (Q1). The Inhibit control has its own internal pull-up to 3 volts. An open-collector or open-drain device is recommended to control this input. **Do not place an external pull-up on this pin.**

Turning Q1 on applies a low voltage to the *Inhibit* control pin and disables the output of the module. If Q1 is then turned off, the module executes a soft-start power-up sequence. A regulated output voltage is produced within 20 ms. Figure 13 shows the typical rise in the output voltage, following the turn off of Q1. The turn off of Q1 corresponds to the rise in the waveform, Q1 V_{DS} . The waveforms were measured with a 2-A resistive load.

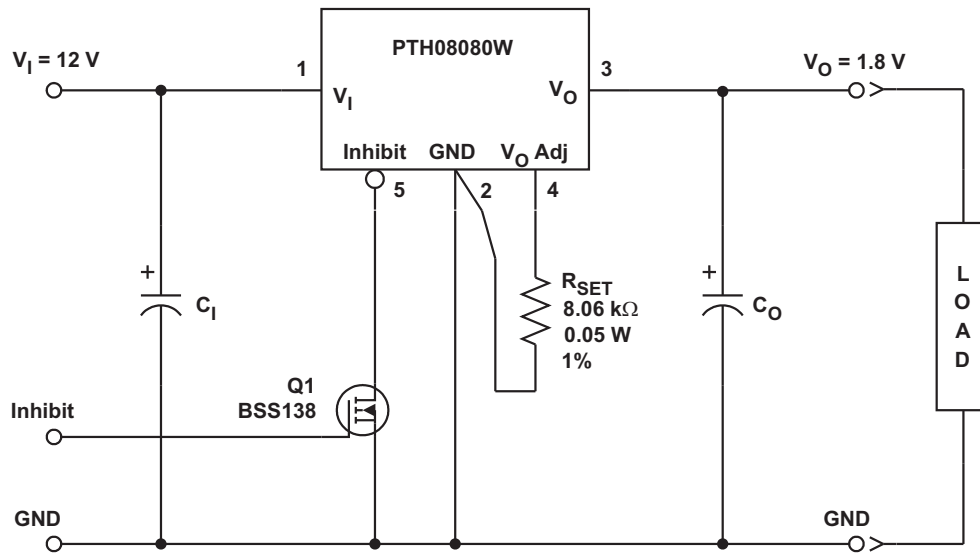

Figure 12. On/Off Inhibit Control Circuit

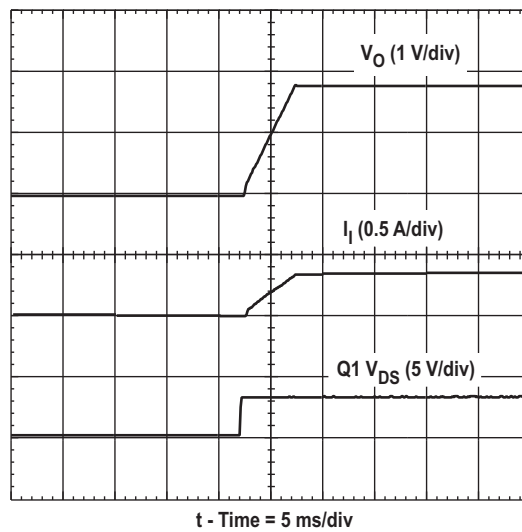

Figure 13. Power-Up Response From Inhibit Control

PACKAGING INFORMATION

Orderable Device	Status ⁽¹⁾	Package Type	Package Drawing	Pins	Package Qty	Eco Plan ⁽²⁾	Lead/Ball Finish	MSL Peak Temp ⁽³⁾
PTH08080WAD	ACTIVE	DIP MOD ULE	EUJ	5	90	Pb-Free (RoHS)	Call TI	N / A for Pkg Type
PTH08080WAH	ACTIVE	DIP MOD ULE	EUJ	5	90	Pb-Free (RoHS)	Call TI	N / A for Pkg Type
PTH08080WAS	ACTIVE	DIP MOD ULE	EUG	5	90	TBD	Call TI	Level-1-235C-UNLIM
PTH08080WAST	ACTIVE	DIP MOD ULE	EUG	5	250	TBD	Call TI	Level-1-235C-UNLIM
PTH08080WAZ	ACTIVE	DIP MOD ULE	EUG	5	90	Pb-Free (RoHS)	Call TI	Level-3-260C-168 HR
PTH08080WAZT	ACTIVE	DIP MOD ULE	EUG	5	250	Pb-Free (RoHS)	Call TI	Level-3-260C-168 HR

⁽¹⁾ The marketing status values are defined as follows:

ACTIVE: Product device recommended for new designs.

LIFEBUY: TI has announced that the device will be discontinued, and a lifetime-buy period is in effect.

NRND: Not recommended for new designs. Device is in production to support existing customers, but TI does not recommend using this part in a new design.

PREVIEW: Device has been announced but is not in production. Samples may or may not be available.

OBSELETE: TI has discontinued the production of the device.

⁽²⁾ Eco Plan - The planned eco-friendly classification: Pb-Free (RoHS), Pb-Free (RoHS Exempt), or Green (RoHS & no Sb/Br) - please check <http://www.ti.com/productcontent> for the latest availability information and additional product content details.

TBD: The Pb-Free/Green conversion plan has not been defined.

Pb-Free (RoHS): TI's terms "Lead-Free" or "Pb-Free" mean semiconductor products that are compatible with the current RoHS requirements for all 6 substances, including the requirement that lead not exceed 0.1% by weight in homogeneous materials. Where designed to be soldered at high temperatures, TI Pb-Free products are suitable for use in specified lead-free processes.

Pb-Free (RoHS Exempt): This component has a RoHS exemption for either 1) lead-based flip-chip solder bumps used between the die and package, or 2) lead-based die adhesive used between the die and leadframe. The component is otherwise considered Pb-Free (RoHS compatible) as defined above.

Green (RoHS & no Sb/Br): TI defines "Green" to mean Pb-Free (RoHS compatible), and free of Bromine (Br) and Antimony (Sb) based flame retardants (Br or Sb do not exceed 0.1% by weight in homogeneous material)

⁽³⁾ MSL, Peak Temp. -- The Moisture Sensitivity Level rating according to the JEDEC industry standard classifications, and peak solder temperature.

Important Information and Disclaimer:The information provided on this page represents TI's knowledge and belief as of the date that it is provided. TI bases its knowledge and belief on information provided by third parties, and makes no representation or warranty as to the accuracy of such information. Efforts are underway to better integrate information from third parties. TI has taken and continues to take reasonable steps to provide representative and accurate information but may not have conducted destructive testing or chemical analysis on incoming materials and chemicals. TI and TI suppliers consider certain information to be proprietary, and thus CAS numbers and other limited information may not be available for release.

In no event shall TI's liability arising out of such information exceed the total purchase price of the TI part(s) at issue in this document sold by TI to Customer on an annual basis.

EU5 (R-PDSS-T5)

DOUBLE SIDED MODULE

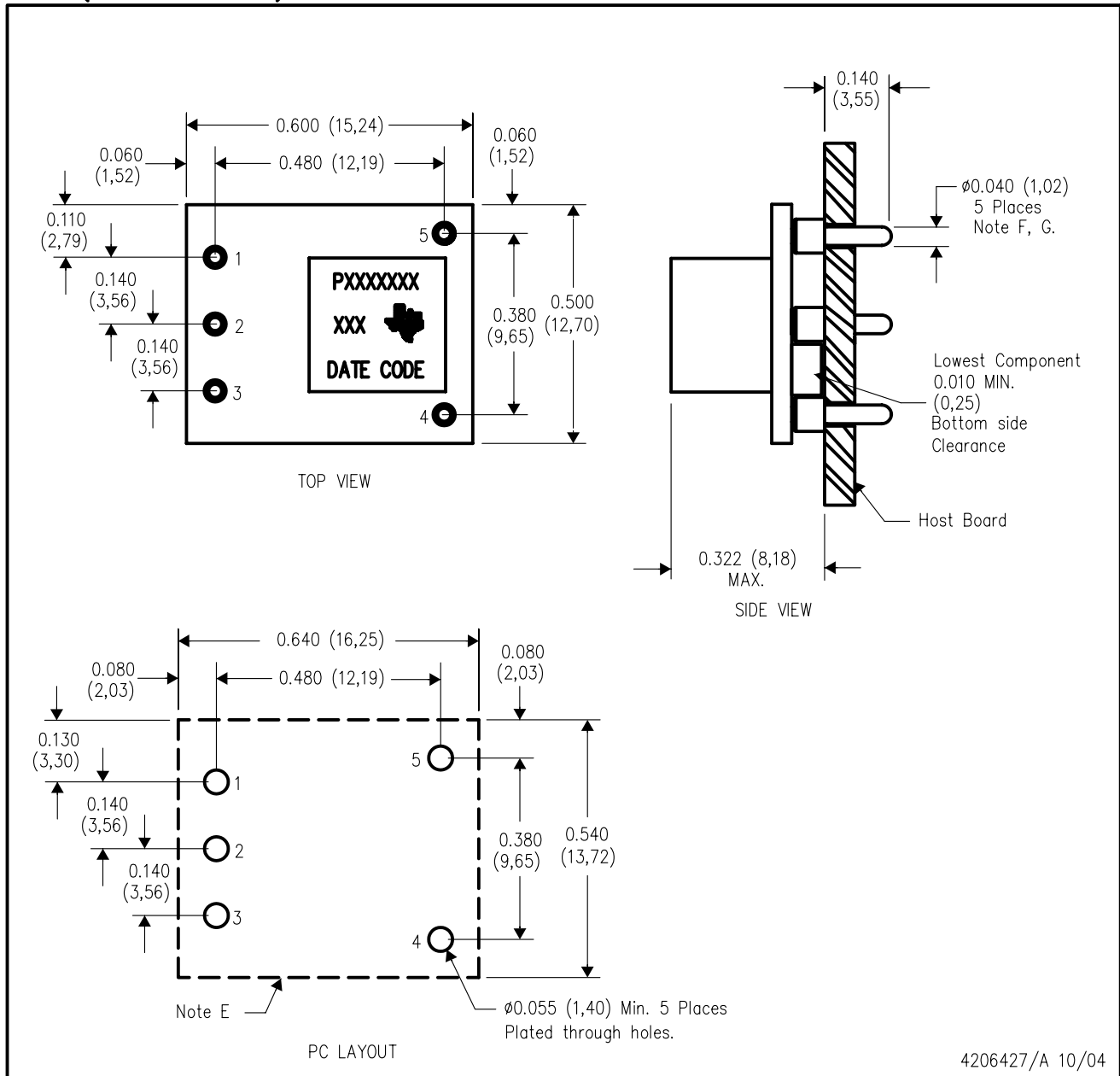

4206427/A 10/04

- NOTES:
- A. All linear dimensions are in inches (mm).
 - B. This drawing is subject to change without notice.
 - C. 2 place decimals are ± 0.030 ($\pm 0,76$ mm).
 - D. 3 place decimals are ± 0.010 ($\pm 0,25$ mm).
 - E. Recommended keep out area for user components.

- F. Pins are 0.040" (1,02) diameter with 0.070" (1,78) diameter standoff shoulder.
- G. All pins: Material - Copper Alloy
Finish - Tin (100%) over Nickel plate

EUG (R-PDSS-B5)

DOUBLE SIDED MODULE

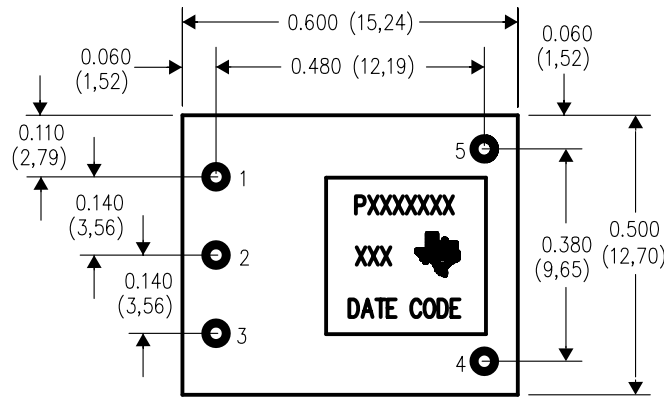

TOP VIEW

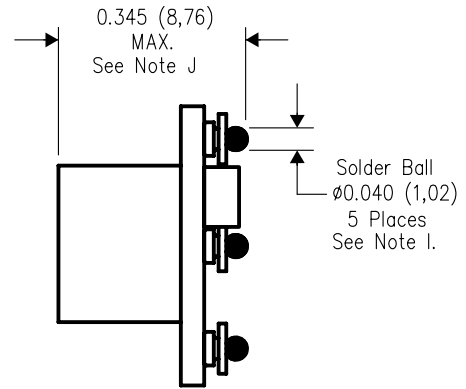

SIDE VIEW

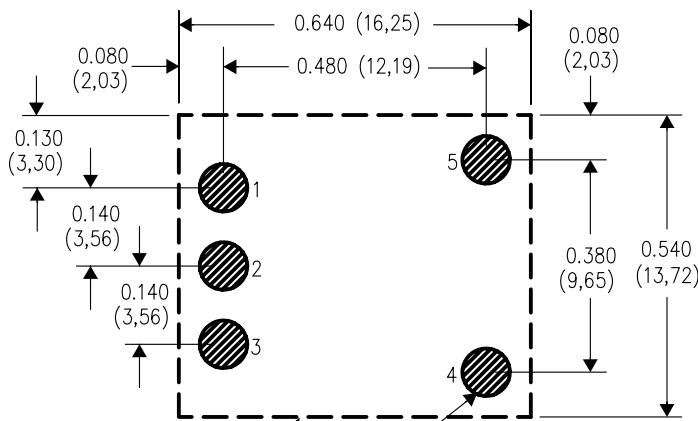

PC LAYOUT

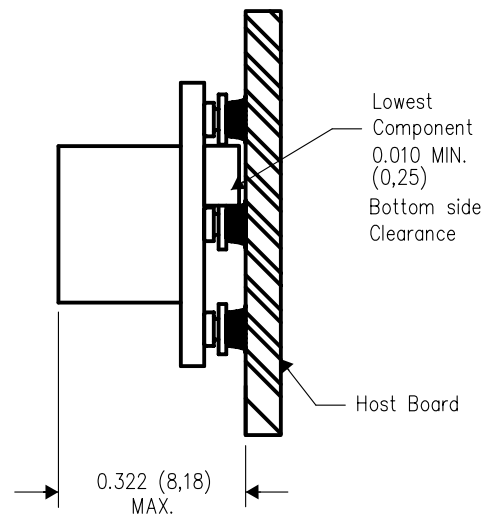

4206428/A 10/04

- NOTES:
- A. All linear dimensions are in inches (mm).
 - B. This drawing is subject to change without notice.
 - C. 2 place decimals are ± 0.030 ($\pm 0,76$ mm).
 - D. 3 place decimals are ± 0.010 ($\pm 0,25$ mm).
 - E. Recommended keep out area for user components.
 - F. Power pin connection should utilize two or more vias to the interior power plane of 0.025 (0,63) I.D. per input, ground and output pin (or the electrical equivalent).

- G. Paste screen opening: 0.080 (2,03) to 0.085 (2,16).
Paste screen thickness: 0.006 (0,15).
- H. Pad type: Solder mask defined.
- I. All pins: Material – Copper Alloy
Finish – Tin (100%) over Nickel plate
Solder Ball – See product data sheet.
- J. Dimension prior to reflow solder.

IMPORTANT NOTICE

Texas Instruments Incorporated and its subsidiaries (TI) reserve the right to make corrections, modifications, enhancements, improvements, and other changes to its products and services at any time and to discontinue any product or service without notice. Customers should obtain the latest relevant information before placing orders and should verify that such information is current and complete. All products are sold subject to TI's terms and conditions of sale supplied at the time of order acknowledgment.

TI warrants performance of its hardware products to the specifications applicable at the time of sale in accordance with TI's standard warranty. Testing and other quality control techniques are used to the extent TI deems necessary to support this warranty. Except where mandated by government requirements, testing of all parameters of each product is not necessarily performed.

TI assumes no liability for applications assistance or customer product design. Customers are responsible for their products and applications using TI components. To minimize the risks associated with customer products and applications, customers should provide adequate design and operating safeguards.

TI does not warrant or represent that any license, either express or implied, is granted under any TI patent right, copyright, mask work right, or other TI intellectual property right relating to any combination, machine, or process in which TI products or services are used. Information published by TI regarding third-party products or services does not constitute a license from TI to use such products or services or a warranty or endorsement thereof. Use of such information may require a license from a third party under the patents or other intellectual property of the third party, or a license from TI under the patents or other intellectual property of TI.

Reproduction of information in TI data books or data sheets is permissible only if reproduction is without alteration and is accompanied by all associated warranties, conditions, limitations, and notices. Reproduction of this information with alteration is an unfair and deceptive business practice. TI is not responsible or liable for such altered documentation.

Resale of TI products or services with statements different from or beyond the parameters stated by TI for that product or service voids all express and any implied warranties for the associated TI product or service and is an unfair and deceptive business practice. TI is not responsible or liable for any such statements.

Following are URLs where you can obtain information on other Texas Instruments products and application solutions:

Products		Applications	
Amplifiers	amplifier.ti.com	Audio	www.ti.com/audio
Data Converters	dataconverter.ti.com	Automotive	www.ti.com/automotive
DSP	dsp.ti.com	Broadband	www.ti.com/broadband
Interface	interface.ti.com	Digital Control	www.ti.com/digitalcontrol
Logic	logic.ti.com	Military	www.ti.com/military
Power Mgmt	power.ti.com	Optical Networking	www.ti.com/opticalnetwork
Microcontrollers	microcontroller.ti.com	Security	www.ti.com/security
Low Power Wireless	www.ti.com/lpw	Telephony	www.ti.com/telephony
		Video & Imaging	www.ti.com/video
		Wireless	www.ti.com/wireless

Mailing Address: Texas Instruments
Post Office Box 655303 Dallas, Texas 75265