



MICROCHIP

PIC18F6620/8620/6720/8720

PIC18F6620/8620/6720/8720 Rev. A3 Silicon/Data Sheet Errata

The PIC18F6620/8620/6720/8720 parts you have received conform functionally to the Device Data Sheet (DS39609B), except for the anomalies described below.

All of the issues listed here will be addressed in future revisions of the PIC18F6620/8620/6720/8720 silicon.

The following silicon errata apply only to PIC18F6620/8620/6720/8720 devices with these Device/Revision IDs:

Part Number	Device ID	Revision ID
PIC18F6620	00 0110 011	00011
PIC18F6720	00 0110 001	00011
PIC18F8620	00 0110 010	00011
PIC18F8720	00 0110 000	00011

The Device IDs (DEVID1 and DEVID2) are located at addresses 3FFFFEh:3FFFFFh in the device's configuration space. They are shown in hexadecimal in the format "DEVID2 DEVID1".

1. Module: Core

Certain code sequence and placement may cause the corruption of a few bits in the instruction fetch when the part is used above 4 MHz. A corrupted instruction fetch will cause the part to execute an improper instruction and result in unpredictable outputs.

Microchip cannot predict which code sequences and placement will cause this failure. If this failure mechanism exists in your system, it should be evident during statistically significant pre-production testing (minimum suggested sample size: 100 units) of your particular code sequence and placement.

Any code changes should be tested in the same manner prior to their implementation. If most parts fail your tests, or if failures are seen at all voltages or at all frequencies, this indicates that the problem experienced does not relate to this failure mechanism.

This problem has not been observed at operating frequencies below 4 MHz.

Work around

Use the part at or below 4 MHz.

Date Codes that pertain to this issue:

This problem is specific to Rev. A3 silicon and has been resolved by Rev. A4 (devices with date code 0421 or later) of the silicon.

PIC18F6620/8620/6720/8720

2. Module: Core (Program Memory Space)

Performing table read operations above the user program memory space (addresses over 1FFFFFFh) may yield erroneous results at the extreme low end of the device's rated temperature range (-40°C).

This applies specifically to addresses above 1FFFFFFh, including the user ID locations (200000h-200007h), the configuration bytes (300000h-30000Dh) and the device ID locations (3FFFFFFh and 3FFFFFFh). User program memory is unaffected.

Work around

Two possible work arounds are presented. Other solutions may exist.

1. Do not perform table read operations on areas above the user memory space at -40°C.
2. Insert NOP instructions (specifically, literal FFFFh) around any table read instructions. The suggested optimal number is 4 instructions before and 8 instructions after each table read. This may vary depending upon the particular application and should be optimized by the user.

Date Codes that pertain to this issue:

All engineering and production devices.

3. Module: External Memory Interface (PIC18F8620 only)

In Extended Microcontroller mode, or Micro-processor mode, the external memory interface is inactive from 20000h to 2FFFFFFh. ALE and WRL signals are inactive between 20000h and 2FFFFFFh.

Work around

Shift RAM space to 30000h and above, or as an alternate solution, the PIC18F8720 device can be used.

This issue will be resolved in a future version of silicon.

Date Codes that pertain to this issue:

All engineering and production devices.

4. Module: I/O Ports (Parallel Slave Port)

While operating in Parallel Slave Port mode, the OBF bit (PSPCON<6>) is supposed to be set when a byte is written to either PORTD or LATD. It has been noted that OBF may not be correctly set when a byte is written to LATD. If the byte is written to PORTD, then the OBF bit is set correctly.

Work around

To ensure the OBF bit is set correctly, write to PORTD rather than LATD.

Date Codes that pertain to this issue:

All engineering and production devices.

5. Module: A/D (External Voltage Reference and Comparator Voltage Reference)

When the external voltage reference, VREF-, is selected for use with either the A/D or comparator voltage reference, AVSS is connected to VREF- in the comparator module. If VREF- is a voltage other than AVSS (which must be tied externally to VSS), excessive current will flow into the VREF- pin.

Work around

If external VREF- is used with a voltage other than 0V, enable the comparator voltage reference by setting the CVREN bit in the CVRCON register. This disconnects VREF- and AVSS within the comparator module.

Date Codes that pertain to this issue:

All engineering and production devices.

6. Module: DAW Instruction

The DAW instruction may improperly clear the Carry bit (STATUS<0>) when executed.

Work around

Test the Carry bit state before executing the DAW instruction. If the Carry bit is set, increment the next higher byte to be added, using an instruction such as INCFSZ (this instruction does not affect any Status flags and will not overflow a BCD nibble). After the DAW instruction has been executed, process the Carry bit normally (see Example 1).

EXAMPLE 1: PROCESSING THE CARRY BIT DURING BCD ADDITIONS

```

MOVLW  0x80      ; .80 (BCD)
ADDLW  0x80      ; .80 (BCD)

BTFSC  STATUS,C  ; test C
INCFSZ byte2     ; inc next higher LSB
DAW

BTFSC  STATUS,C  ; test C
INCFSZ byte2     ; inc next higher LSB

This is repeated for each DAW instruction
    
```

Date Codes that pertain to this issue:

All engineering and production devices.

7. Module: External Memory Interface (PIC18F8720 and PIC18F8620 only)

When performing writes on the external memory interface, a short glitch is present on the \overline{LB} and \overline{UB} lines. The length of the glitch is proportional to FOSC and also may vary with process, voltage and temperature. The glitch occurs well before the \overline{WRH} line is asserted and no adverse affect on the operation of the external memory interface has been observed.

Work around

None

Date Codes that pertain to this issue:

All engineering and production devices.

8. Module: MSSP (All I²C™ and SPI™ Modes)

The Buffer Full (BF) flag bit of the SSPSTAT register (SSPSTAT<0>) may be inadvertently cleared even when the SSPBUF register has not been read. This will occur only when the following two conditions occur simultaneously:

- The four Least Significant bits of the BSR register are equal to 0Fh (BSR<3:0> = 1111); and
- Any instruction that contains C9h in its 8 Least Significant bits (i.e., register file addresses, literal data, address offsets, etc.) is executed.

Work around

All work arounds will involve setting the contents of BSR<3:0> to some value other than 0Fh.

In addition to those proposed below, other solutions may exist.

1. When developing or modifying code, keep these guidelines in mind:
 - Assign 12-bit addresses to all variables. This allows the assembler to know when Access Banking can be used.
 - Do not set the BSR to point to Bank 15 (BSR = 0Fh).
 - Allow the assembler to manipulate the access bit present in most instructions. Accessing the SFRs in Bank 15 will be done through the Access Bank. Continue to use the BSR to select all GPR Banks.
2. If accessing a part of Bank 15 is required and the use of Access Banking is not possible, consider using indirect addressing.
3. If pointing the BSR to Bank 15 is unavoidable, review the absolute file listing. Verify that no instructions contain C9h in the 8 Least Significant bits while the BSR points to Bank 15 (BSR = 0Fh).

Date Codes that pertain to this issue:

All engineering and production devices.

PIC18F6620/8620/6720/8720

9. Module: Reset

It has been observed that in certain Reset conditions, including power-up, the first `GOTO` instruction at address `0x0000` may not be executed. This occurrence is rare and affects very few applications.

To determine if your system is affected, test a statistically significant number of applications across the operating temperature, voltage and frequency ranges of the application. Affected systems will repeatably fail normal testing. Systems not affected will continue to not be affected over time.

Work around

Insert a `NOP` instruction at address `0x0000`.

Date Codes that pertain to this issue:

All engineering and production devices.

PIC18F6620/8620/6720/8720

Clarifications/Corrections to the Data Sheet:

In the Device Data Sheet (DS39609B), the following clarifications and corrections should be noted.

1. Module: Voltage-Frequency Graph

In Section 26.0 “Electrical Characteristics”, the following figure has been updated to clarify the voltage frequency for extended devices.

FIGURE 26-3: PIC18F6620/6720/8620/8720 VOLTAGE-FREQUENCY GRAPH (INDUSTRIAL, EXTENDED)

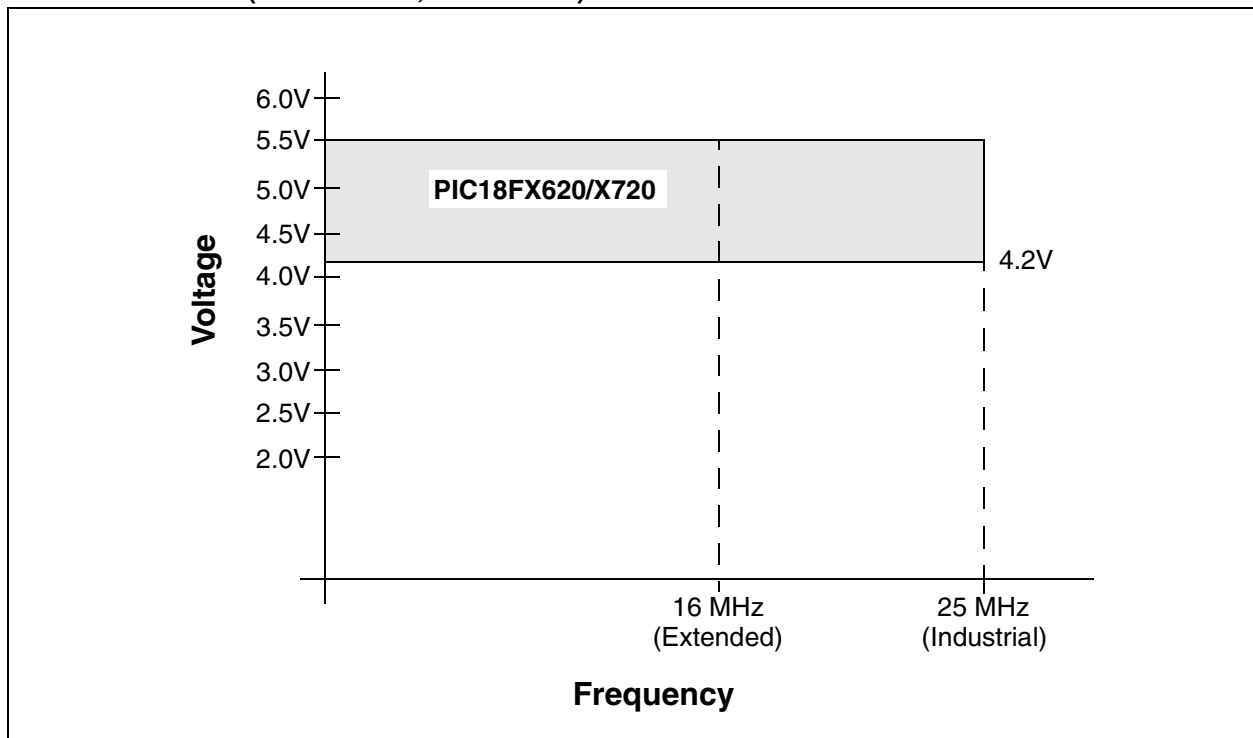

PIC18F6620/8620/6720/8720

2. Module: Timing Diagrams and Specifications

Table 26-6: External Clock Timing Requirements for PIC18FX620/X720 devices (page 322) has been revised (changes and additions are shown in **bold text**).

TABLE 26-6: EXTERNAL CLOCK TIMING REQUIREMENTS

Param No.	Symbol	Characteristic	Min	Max	Units	Conditions
1A	Fosc	External CLKI Frequency ⁽¹⁾	DC	25	MHz	EC, ECIO oscillator, PIC18FX620/X720 (Industrial)
			DC	16	MHz	EC, ECIO oscillator, PIC18FX620/X720 (Extended)
		Oscillator Frequency ⁽¹⁾	DC	4	MHz	RC oscillator
			0.1	4	MHz	XT oscillator
			4	25	MHz	HS oscillator (Industrial)
			4	16	MHz	HS oscillator (Extended)
			4	6.25	MHz	HS + PLL oscillator, PIC18FX620/X720 (Industrial)
			4	4	MHz	HS + PLL oscillator, PIC18FX620/X720 (Extended)
5	33	kHz	LP Oscillator mode			
1	Tosc	External CLKI Period ⁽¹⁾	40	—	ns	EC, ECIO oscillator, PIC18FX620/X720 (Industrial)
			62.5	—	ns	EC, ECIO oscillator, PIC18FX620/X720 (Extended)
		Oscillator Period ⁽¹⁾	250	—	ns	RC oscillator
			250	10,000	ns	XT oscillator
			40	250	ns	HS oscillator (Industrial)
			62.5	250	ns	HS oscillator (Extended)
			160	250	ns	HS + PLL oscillator, PIC18FX620/X720 (Industrial)
			250	250	ns	HS + PLL oscillator, PIC18FX620/X720 (Extended)
			30	200	μs	LP Oscillator mode

Note 1: Instruction cycle period (Tcy) equals four times the input oscillator time base period for all configurations except PLL. All specified values are based on characterization data for that particular oscillator type under standard operating conditions with the device executing code. Exceeding these specified limits may result in an unstable oscillator operation and/or higher than expected current consumption. All devices are tested to operate at “min.” values with an external clock applied to the OSC1/CLKI pin. When an external clock input is used, the “max.” cycle time limit is “DC” (no clock) for all devices.

3. Module: CCP

In **Section 23.3.1 “Wake-up From Sleep”**, the list of peripheral interrupts which can wake the device from Sleep has been updated. From the list of 11 events, item 4 has been clarified and item 5 has been removed. The list now reads as follows:

1. PSP read or write.
2. TMR1 interrupt. Timer1 must be operating as an asynchronous counter.
3. TMR3 interrupt. Timer3 must be operating as an asynchronous counter.
4. CCP Capture mode interrupt (Capture will not occur).
5. MSSP (Start/Stop) bit detect interrupt.
6. MSSP transmit or receive in Slave mode (SPI/I²C).
7. USART RX or TX (Synchronous Slave mode).
8. A/D conversion (when A/D clock source is RC).
9. EEPROM write operation complete.
10. LVD interrupt.

PIC18F6620/8620/6720/8720

4. Module: Voltage Reference Specifications

In Table 26-2: Voltage Reference Specifications (page 317), parameter D311, VRAA, should be replaced with the following:

TABLE 26-2: VOLTAGE REFERENCE SPECIFICATIONS

Operating Conditions: 3.0V < VDD < 5.5V, -40°C < TA < +125°C (unless otherwise stated).							
Param No.	Sym	Characteristics	Min	Typ	Max	Units	Comments
D311	VRAA	Absolute Accuracy	—	—	1/2	LSb	

Note 1: Settling time measured while VRR = 1 and VR<3:0> transitions from '0000' to '1111'.

5. Module: Memory Programming Requirements

In Table 26-4: Memory Programming Requirements (page 319), specification D124 (TREF) and Note 4 have been added:

TABLE 26-4: MEMORY PROGRAMMING REQUIREMENTS

DC Characteristics			Standard Operating Conditions (unless otherwise stated) Operating temperature -40°C ≤ TA ≤ +85°C for industrial -40°C ≤ TA ≤ +125°C for extended				
Param No.	Sym	Characteristic	Min	Typ†	Max	Units	Conditions
D124	TREF	Data EEPROM Memory					
		Total Number of Erase/Write Cycles before Refresh (Note 4)	1M 100K	10M 1M	— —	E/W E/W	-40°C to +85°C -40°C to +125°C

† Data in "Typ" column is at 5.0V, 25°C unless otherwise stated. These parameters are for design guidance only and are not tested.

- Note 1:** These specifications are for programming the on-chip program memory through the use of table write instructions.
- 2:** The pin may be kept in this range at times other than programming, but it is not recommended.
- 3:** Retention time is valid, provided no other specifications are violated.
- 4:** Refer to **Section 7.8 "Using the Data EEPROM"** for a more detailed discussion on data EEPROM endurance.

PIC18F6620/8620/6720/8720

6. Module: DC Characteristics

In Section 26-3 “DC Characteristics” (page 315), the specifications for V_{IL} and V_{IH} have been clarified and now read as follows (changes and additions are shown in **bold** text):

26.3 DC Characteristics PIC18F6620/8620/6720/8720 (Industrial, Extended) PIC18LF6620/8620/6720/8720 (Industrial)

DC CHARACTERISTICS			Standard Operating Conditions (unless otherwise stated) Operating temperature $-40^{\circ}\text{C} \leq T_A \leq +85^{\circ}\text{C}$ for industrial $-40^{\circ}\text{C} \leq T_A \leq +125^{\circ}\text{C}$ for extended			
Param No.	Sym	Characteristic	Min	Max	Units	Conditions
	V_{IL}	Input Low Voltage I/O ports:				
D030		with TTL buffer	V_{SS}	$0.15 V_{DD}$	V	$V_{DD} < 4.5\text{V}$
D030A			—	0.8	V	$4.5\text{V} \leq V_{DD} \leq 5.5\text{V}$
D031		with Schmitt Trigger buffer RC3 and RC4	V_{SS}	$0.2 V_{DD}$	V	
D032		$\overline{\text{MCLR}}$	V_{SS}	$0.3 V_{DD}$	V	
D032A		OSC1 (in XT, HS and LP modes) and T1OSI	V_{SS}	$0.2 V_{DD}$	V	
D033		OSC1	V_{SS}	$0.3 V_{DD}$	V	HS, HSPLL modes
D033A		OSC1	V_{SS}	$0.2 V_{DD}$	V	RC, EC modes⁽¹⁾
D033B		OSC1	V_{SS}	0.3	V	XT, LP modes
D034		T13CKI	V_{SS}	0.3	V	
	V_{IH}	Input High Voltage I/O ports:				
D040		with TTL buffer	$0.25 V_{DD} + 0.8\text{V}$	V_{DD}	V	$V_{DD} < 4.5\text{V}$
D040A			2.0	V_{DD}	V	$4.5\text{V} \leq V_{DD} \leq 5.5\text{V}$
D041		with Schmitt Trigger buffer RC3 and RC4	$0.8 V_{DD}$	V_{DD}	V	
D042		$\overline{\text{MCLR}}$, OSC1 (EC mode)	$0.7 V_{DD}$	V_{DD}	V	
D042A		OSC1 and T1OSI	1.6	V_{DD}	V	LP, XT, HS, HSPLL modes ⁽¹⁾
D043		OSC1	$0.7 V_{DD}$	V_{DD}	V	HS, HSPLL modes
D043A		OSC1	$0.8 V_{DD}$	V_{DD}	V	EC mode
D043B		OSC1	$0.9 V_{DD}$	V_{DD}	V	RC mode⁽¹⁾
D043C		OSC1	1.6	V_{DD}	V	XT, LP modes
D044		T13CKI	1.6	V_{DD}	V	

- Note 1:** In RC oscillator configuration, the OSC1/CLKI pin is a Schmitt Trigger input. It is not recommended that the PICmicro[®] device be driven with an external clock while in RC mode.
- 2:** The leakage current on the $\overline{\text{MCLR}}$ pin is strongly dependent on the applied voltage level. The specified levels represent normal operating conditions. Higher leakage current may be measured at different input voltages.
- 3:** Negative current is defined as current sourced by the pin.
- 4:** Parameter is characterized but not tested.

PIC18F6620/8620/6720/8720

7. Module: Instruction Set (BTG)

In Table 24-1: PIC18FXXXX Instruction Set (page 262), the BTG instruction has been changed (change shown in **bold text**).

TABLE 24-1: PIC18FXXXX INSTRUCTION SET

Mnemonic, Operands	Description	Cycles	16-Bit Instruction Word				Status Affected	Notes	
			MSb			LSb			
BIT-ORIENTED FILE REGISTER OPERATIONS									
BTG	f, b, a	Bit Toggle f	1	0111	bbba	ffff	ffff	None	1, 2

8. Module: OSCCON Register

In the OSCCON register (Register 2-1, page 25), the Reset value for the SCS bit (OSCCON<0>) was incorrectly stated as R/W-1 and has been changed to R/W-0.

9. Module: A/D Converter Characteristics

In Table 26-25: A/D Converter Characteristics (page 340), specification A40 and Note 6 have been added:

**TABLE 26-25: A/D CONVERTER CHARACTERISTICS: PIC18FXX20 (INDUSTRIAL, EXTENDED)
PIC18LFX20 (INDUSTRIAL)**

Param No.	Symbol	Characteristic	Min	Typ	Max	Units	Conditions
A01	NR	Resolution	—	—	10	bit	
A03	EIL	Integral Linearity Error	—	—	<±1	LSb	VREF = VDD = 5.0V
A04	EDL	Differential Linearity Error	—	—	<±1	LSb	VREF = VDD = 5.0V
A05	EG	Gain Error	—	—	<±1	LSb	VREF = VDD = 5.0V
A06	EOFF	Offset Error	—	—	<±1.5	LSb	VREF = VDD = 5.0V
A10	—	Monotonicity	guaranteed ⁽²⁾			—	VSS ≤ VAIN ≤ VREF
A20	VREF	Reference Voltage	1.8V	—	—	V	VDD < 3.0V
A20A		(VREFH – VREFL)	3V	—	—	V	VDD ≥ 3.0V
A21	VREFH	Reference Voltage High	AVSS	—	AVDD + 0.3V	V	
A22	VREFL	Reference Voltage Low	AVSS – 0.3V ⁽⁵⁾	—	VREFH	V	
A25	VAIN	Analog Input Voltage	AVSS – 0.3V ⁽⁵⁾	—	AVDD + 0.3V ⁽⁵⁾	V	VDD ≥ 2.5V (Note 3)
A30	ZAIN	Recommended Impedance of Analog Voltage Source	—	—	2.5	kΩ	(Note 4)
A40	IAD	A/D Current from VDD	—	180	—	μA	Average current during conversion.
		PIC18LFX20	—	90	—	μA	
A50	IREF	VREF Input Current (Note 1)	—	—	5	μA	During VAIN acquisition. During A/D conversion cycle.
			—	—	150	μA	

Note 1: VSS ≤ VAIN ≤ VREF

2: The A/D conversion result never decreases with an increase in the input voltage and has no missing codes.

3: For VDD < 2.5V, VAIN should be limited to <.5 VDD.

4: Maximum allowed impedance for analog voltage source is 10 kΩ. This requires higher acquisition times.

5: IVDD – AVDDI must be <3.0V and IAVSS – VSSI must be <0.3V.

PIC18F6620/8620/6720/8720

10. Module: Timer0 Block Diagram in 8-Bit and 16-Bit Modes

The PSA multiplexor bit values in Figures 11-1 and 11-2 do not match the text description of the Timer0 PSA bit in the T0CON register.

The bit values have been corrected by swapping the values as shown below (correct values are shown in **bold text**):

FIGURE 11-1: TIMER0 BLOCK DIAGRAM IN 8-BIT MODE

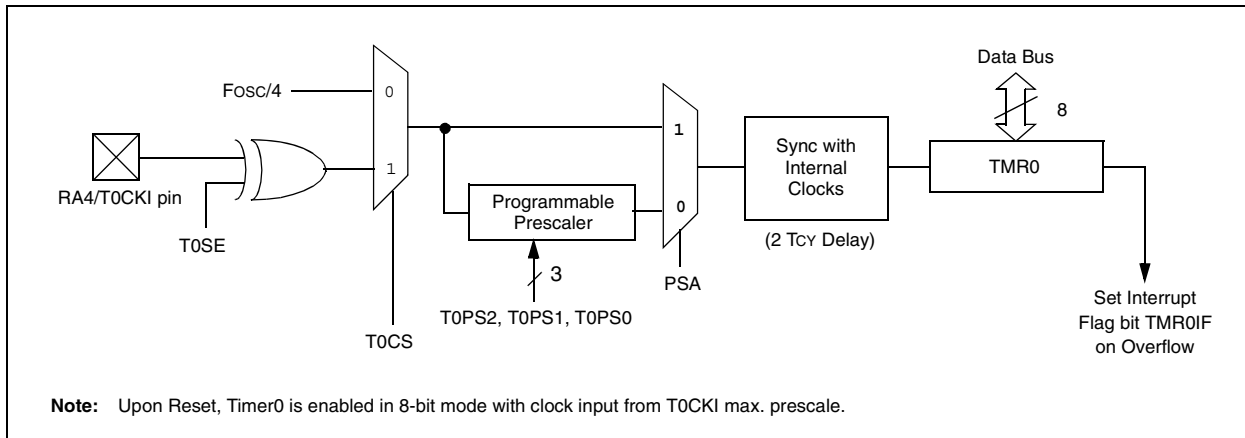
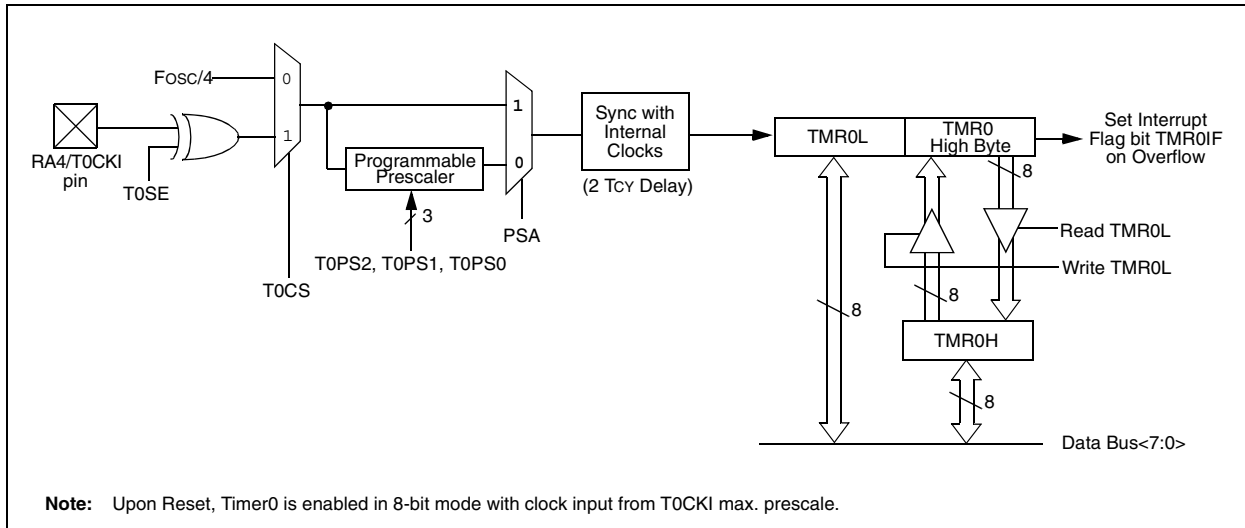

FIGURE 11-2: TIMER0 BLOCK DIAGRAM IN 16-BIT MODE



REVISION HISTORY

Rev A Document (7/2002)

First revision of this document. Data Sheet clarifications 1 through 4 (Core - Pinout, USART, Data EEPROM and ICSP).

Rev B Document (8/2002)

Data Sheet clarification 5 (addition of External Memory Interface).

Rev C Document (1/2003)

Added silicon issues 2 (External Memory Interface) and 3 (Parallel Slave Port), and added Data Sheet clarifications 6 (change to table notes) and 7 (Comparator Voltage Reference).

Rev D Document (2/2003)

Added silicon issue 4 (External A/D Voltage Reference) and added Data Sheet clarification 8 (A/D VREF+ and VREF- References).

Rev E Document (3/2003)

Modified to reflect Data Sheet revisions (literature number changed from DS39580A to DS39609A). Added silicon issue 4 (DAW Instruction), removed Data Sheet clarification issues 1 through 6, modified issue 7 (Comparator Voltage Reference) now issue 1 and previous issue 8 (A/D VREF+ and VREF- References) now issue 2, added issues 3 through 10 (Data EEPROM, Memory, Timer0, Pin Diagrams, MSSP, Voltage-Frequency Graph, Table 26-25: A/D Converter Characteristics and Electrical Characteristics).

Rev F Document (8/2003)

Added silicon issues 1 and 2 (Core) and renumbered previous issues.

Rev G Document (10/2003)

Added silicon issue 7 (External Memory Interface), 8 (MSSP – I²C and SPI modes) and 9 (MSSP – SPI, Slave Mode). Removed Data Sheet clarification 7 (MSSP – SPI Mode).

Rev H Document (12/2004)

Updated device and revision ID information. Updated silicon issue 1 (Core). Removed silicon issue 8 (MSSP – SPI, Slave Mode). Removed previous Data Sheet clarifications (1-6). Updated Data Sheet clarification 7 (Voltage-Frequency Graph), now numbered clarification 1 and added Data Sheet clarification issue 2 (Timing Diagrams and Specifications), 3 (CCP), 4 (Voltage Reference Specifications), 5 (Memory Programming Requirements), 6 (DC Characteristics), 7 (Instruction Set (BTG)), 8 (OSCCON Register), 9 (A/D Converter Characteristics) and 10 (Timer0 Block Diagram in 8-Bit and 16-Bit Modes).

Rev J Document (05/2005)

Added silicon issue 9 (Reset).

PIC18F6620/8620/6720/8720

NOTES:

Note the following details of the code protection feature on Microchip devices:

- Microchip products meet the specification contained in their particular Microchip Data Sheet.
- Microchip believes that its family of products is one of the most secure families of its kind on the market today, when used in the intended manner and under normal conditions.
- There are dishonest and possibly illegal methods used to breach the code protection feature. All of these methods, to our knowledge, require using the Microchip products in a manner outside the operating specifications contained in Microchip's Data Sheets. Most likely, the person doing so is engaged in theft of intellectual property.
- Microchip is willing to work with the customer who is concerned about the integrity of their code.
- Neither Microchip nor any other semiconductor manufacturer can guarantee the security of their code. Code protection does not mean that we are guaranteeing the product as "unbreakable."

Code protection is constantly evolving. We at Microchip are committed to continuously improving the code protection features of our products. Attempts to break Microchip's code protection feature may be a violation of the Digital Millennium Copyright Act. If such acts allow unauthorized access to your software or other copyrighted work, you may have a right to sue for relief under that Act.

Information contained in this publication regarding device applications and the like is provided only for your convenience and may be superseded by updates. It is your responsibility to ensure that your application meets with your specifications. MICROCHIP MAKES NO REPRESENTATIONS OR WARRANTIES OF ANY KIND WHETHER EXPRESS OR IMPLIED, WRITTEN OR ORAL, STATUTORY OR OTHERWISE, RELATED TO THE INFORMATION, INCLUDING BUT NOT LIMITED TO ITS CONDITION, QUALITY, PERFORMANCE, MERCHANTABILITY OR FITNESS FOR PURPOSE. Microchip disclaims all liability arising from this information and its use. Use of Microchip's products as critical components in life support systems is not authorized except with express written approval by Microchip. No licenses are conveyed, implicitly or otherwise, under any Microchip intellectual property rights.

Trademarks

The Microchip name and logo, the Microchip logo, Accuron, dsPIC, KEELOQ, microID, MPLAB, PIC, PICmicro, PICSTART, PRO MATE, PowerSmart, rPIC, and SmartShunt are registered trademarks of Microchip Technology Incorporated in the U.S.A. and other countries.

AmpLab, FilterLab, Migratable Memory, MXDEV, MXLAB, PICMASTER, SEEVAL, SmartSensor and The Embedded Control Solutions Company are registered trademarks of Microchip Technology Incorporated in the U.S.A.

Analog-for-the-Digital Age, Application Maestro, dsPICDEM, dsPICDEM.net, dsPICworks, ECAN, ECONOMONITOR, FanSense, FlexROM, fuzzyLAB, In-Circuit Serial Programming, ICSP, ICEPIC, Linear Active Thermistor, MPASM, MPLIB, MPLINK, MPSIM, PCKIT, PICDEM, PICDEM.net, PICLAB, PICtail, PowerCal, PowerInfo, PowerMate, PowerTool, rLAB, rPICDEM, Select Mode, Smart Serial, SmartTel, Total Endurance and WiperLock are trademarks of Microchip Technology Incorporated in the U.S.A. and other countries.

SQTP is a service mark of Microchip Technology Incorporated in the U.S.A.

All other trademarks mentioned herein are property of their respective companies.

© 2005, Microchip Technology Incorporated, Printed in the U.S.A., All Rights Reserved.

 Printed on recycled paper.

**QUALITY MANAGEMENT SYSTEM
CERTIFIED BY DNV
== ISO/TS 16949:2002 ==**

Microchip received ISO/TS-16949:2002 quality system certification for its worldwide headquarters, design and wafer fabrication facilities in Chandler and Tempe, Arizona and Mountain View, California in October 2003. The Company's quality system processes and procedures are for its PICmicro® 8-bit MCUs, KEELOQ® code hopping devices, Serial EEPROMs, microperipherals, nonvolatile memory and analog products. In addition, Microchip's quality system for the design and manufacture of development systems is ISO 9001:2000 certified.



WORLDWIDE SALES AND SERVICE

AMERICAS

Corporate Office
2355 West Chandler Blvd.
Chandler, AZ 85224-6199
Tel: 480-792-7200
Fax: 480-792-7277
Technical Support:
<http://support.microchip.com>
Web Address:
www.microchip.com

Atlanta
Alpharetta, GA
Tel: 770-640-0034
Fax: 770-640-0307

Boston
Westborough, MA
Tel: 774-760-0087
Fax: 774-760-0088

Chicago
Itasca, IL
Tel: 630-285-0071
Fax: 630-285-0075

Dallas
Addison, TX
Tel: 972-818-7423
Fax: 972-818-2924

Detroit
Farmington Hills, MI
Tel: 248-538-2250
Fax: 248-538-2260

Kokomo
Kokomo, IN
Tel: 765-864-8360
Fax: 765-864-8387

Los Angeles
Mission Viejo, CA
Tel: 949-462-9523
Fax: 949-462-9608

San Jose
Mountain View, CA
Tel: 650-215-1444
Fax: 650-961-0286

Toronto
Mississauga, Ontario,
Canada
Tel: 905-673-0699
Fax: 905-673-6509

ASIA/PACIFIC

Australia - Sydney
Tel: 61-2-9868-6733
Fax: 61-2-9868-6755

China - Beijing
Tel: 86-10-8528-2100
Fax: 86-10-8528-2104

China - Chengdu
Tel: 86-28-8676-6200
Fax: 86-28-8676-6599

China - Fuzhou
Tel: 86-591-8750-3506
Fax: 86-591-8750-3521

China - Hong Kong SAR
Tel: 852-2401-1200
Fax: 852-2401-3431

China - Shanghai
Tel: 86-21-5407-5533
Fax: 86-21-5407-5066

China - Shenyang
Tel: 86-24-2334-2829
Fax: 86-24-2334-2393

China - Shenzhen
Tel: 86-755-8203-2660
Fax: 86-755-8203-1760

China - Shunde
Tel: 86-757-2839-5507
Fax: 86-757-2839-5571

China - Qingdao
Tel: 86-532-502-7355
Fax: 86-532-502-7205

ASIA/PACIFIC

India - Bangalore
Tel: 91-80-2229-0061
Fax: 91-80-2229-0062

India - New Delhi
Tel: 91-11-5160-8631
Fax: 91-11-5160-8632

Japan - Kanagawa
Tel: 81-45-471- 6166
Fax: 81-45-471-6122

Korea - Seoul
Tel: 82-2-554-7200
Fax: 82-2-558-5932 or
82-2-558-5934

Malaysia - Penang
Tel: 011-604-646-8870
Fax: 011-604-646-5086

Philippines - Manila
Tel: 011-632-634-9065
Fax: 011-632-634-9069

Singapore
Tel: 65-6334-8870
Fax: 65-6334-8850

Taiwan - Kaohsiung
Tel: 886-7-536-4818
Fax: 886-7-536-4803

Taiwan - Taipei
Tel: 886-2-2500-6610
Fax: 886-2-2508-0102

Taiwan - Hsinchu
Tel: 886-3-572-9526
Fax: 886-3-572-6459

EUROPE

Austria - Weis
Tel: 43-7242-2244-399
Fax: 43-7242-2244-393

Denmark - Ballerup
Tel: 45-4450-2828
Fax: 45-4485-2829

France - Massy
Tel: 33-1-69-53-63-20
Fax: 33-1-69-30-90-79

Germany - Ismaning
Tel: 49-89-627-144-0
Fax: 49-89-627-144-44

Italy - Milan
Tel: 39-0331-742611
Fax: 39-0331-466781

Netherlands - Drunen
Tel: 31-416-690399
Fax: 31-416-690340

England - Berkshire
Tel: 44-118-921-5869
Fax: 44-118-921-5820