

## REMOTE 16-BIT I<sup>2</sup>C AND SMBus I/O EXPANDER WITH INTERRUPT OUTPUT AND CONFIGURATION REGISTERS

### FEATURES

- Low Standby-Current Consumption of 1  $\mu$ A Max
- I<sup>2</sup>C to Parallel Port Expander
- Open-Drain Active-Low Interrupt Output
- 5-V Tolerant I/O Ports
- Compatible With Most Microcontrollers
- 400-kHz Fast I<sup>2</sup>C Bus
- Address by Three Hardware Address Pins for Use of up to Eight Devices
- Polarity Inversion Register
- Latched Outputs With High-Current Drive Capability for Directly Driving LEDs
- Latch-Up Performance Exceeds 100 mA Per JESD 78, Class II
- ESD Protection Exceeds JESD 22
  - 2000-V Human-Body Model (A114-A)
  - 200-V Machine Model (A115-A)
  - 1000-V Charged-Device Model (C101)

DB, DBQ, DGV, DW, OR PW PACKAGE  
(TOP VIEW)

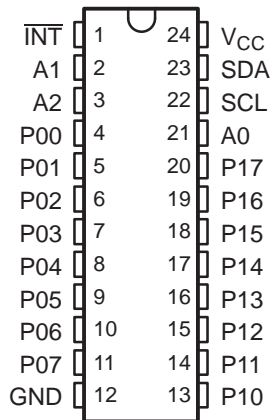

RGE PACKAGE  
(TOP VIEW)

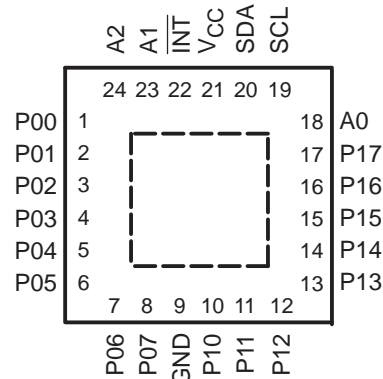

### DESCRIPTION/ORDERING INFORMATION

This 16-bit I/O expander for the two-line bidirectional bus (I<sup>2</sup>C) is designed for 2.3-V to 5.5-V  $V_{CC}$  operation. It provides general-purpose remote I/O expansion for most microcontroller families via the I<sup>2</sup>C interface [serial clock (SCL), serial data (SDA)].

The PCA9555 consists of two 8-bit Configuration (input or output selection), Input Port, Output Port, and Polarity Inversion (active high or active low operation) registers. At power on, the I/Os are configured as inputs. The system master can enable the I/Os as either inputs or outputs by writing to the I/O configuration bits. The data for each input or output is kept in the corresponding Input or Output register. The polarity of the Input Port register can be inverted with the Polarity Inversion register. All registers can be read by the system master.

The system master can reset the PCA9555 in the event of a timeout or other improper operation by utilizing the power-on reset feature, which puts the registers in their default state and initializes the I<sup>2</sup>C/SMBus state machine.

The PCA9555 open-drain interrupt ( $\overline{\text{INT}}$ ) output is activated when any input state differs from its corresponding Input Port register state and is used to indicate to the system master that an input state has changed.

$\overline{\text{INT}}$  can be connected to the interrupt input of a microcontroller. By sending an interrupt signal on this line, the remote I/O can inform the microcontroller if there is incoming data on its ports without having to communicate via the I<sup>2</sup>C bus. Thus, the PCA9555 can remain a simple slave device.



Please be aware that an important notice concerning availability, standard warranty, and use in critical applications of Texas Instruments semiconductor products and disclaimers thereto appears at the end of this data sheet.

## DESCRIPTION/ORDERING INFORMATION (CONTINUED)

The device outputs (latched) have high-current drive capability for directly driving LEDs.

Although pin-to-pin and I<sup>2</sup>C-address is compatible with the PCF8575, software changes are required due to the enhancements.

The PCA9555 is identical to the PCA9535, except for the inclusion of the internal I/O pullup resistor, which pulls the I/O to a default high when configured as an input and undriven.

Three hardware pins (A0, A1, and A2) are used to program and vary the fixed I<sup>2</sup>C address and allow up to eight devices to share the same I<sup>2</sup>C bus or SMBus. The fixed I<sup>2</sup>C address of the PCA9555 is the same as the PCF8575, PCF8575C, and PCF8574, allowing up to eight of these devices in any combination to share the same I<sup>2</sup>C bus or SMBus.

### ORDERING INFORMATION

T <sub>A</sub>	PACKAGE <sup>(1)(2)</sup>		ORDERABLE PART NUMBER	TOP-SIDE MARKING	
–40°C to 85°C	SSOP – DB	Reel of 2000	PCA9555DBR	PD9555	
		Tube of 60	PCA9555DB		
	QSOP – DBQ	Reel of 2500		PCA9555DBQR	PCA9555
				PCA9555DBQRG4	
	TVSOP – DGV	Reel of 2000		PCA9555DGVR	PD9555
	SOIC – DW	Tube of 25		PCA9555DW	PCA9555
		Reel of 2000		PCA9555DWR	
		Reel of 250		PCA9555DWT	
	TSSOP – PW	Tube of 60		PCA9555PW	PD9555
				PCA9555PWE4	
		Reel of 2000		PCA9555PWR	
				PCA9555PWRE4	
	Reel of 250		PCA9555PWT		
QFN – RGE	Reel of 3000		PCA9555RGER	PD9555	

(1) Package drawings, thermal data, and symbolization are available at [www.ti.com/packaging](http://www.ti.com/packaging).

(2) For the most current package and ordering information, see the Package Option Addendum at the end of this document, or see the TI website at [www.ti.com](http://www.ti.com).

**TERMINAL FUNCTIONS**

NO.		NAME	DESCRIPTION
SOIC (D), SSOP (DB), QSOP (DBQ), TSSOP (PW), AND TVSOP (DGV)	QFN (RGE)		
1	22	$\overline{\text{INT}}$	Interrupt output. Connect to $V_{CC}$ through a pullup resistor.
2	23	A1	Address input 1. Connect directly to $V_{CC}$ or ground.
3	24	A2	Address input 2. Connect directly to $V_{CC}$ or ground.
4	1	P00	P-port input/output. Push-pull design structure.
5	2	P01	P-port input/output. Push-pull design structure.
6	3	P02	P-port input/output. Push-pull design structure.
7	4	P03	P-port input/output. Push-pull design structure.
8	5	P04	P-port input/output. Push-pull design structure.
9	6	P05	P-port input/output. Push-pull design structure.
10	7	P06	P-port input/output. Push-pull design structure.
11	8	P07	P-port input/output. Push-pull design structure.
12	9	GND	Ground
13	10	P10	P-port input/output. Push-pull design structure.
14	11	P11	P-port input/output. Push-pull design structure.
15	12	P12	P-port input/output. Push-pull design structure.
16	13	P13	P-port input/output. Push-pull design structure.
17	14	P14	P-port input/output. Push-pull design structure.
18	15	P15	P-port input/output. Push-pull design structure.
19	16	P16	P-port input/output. Push-pull design structure.
20	17	P17	P-port input/output. Push-pull design structure.
21	18	A0	Address input 0. Connect directly to $V_{CC}$ or ground.
22	19	SCL	Serial clock bus. Connect to $V_{CC}$ through a pullup resistor.
23	20	SDA	Serial data bus. Connect to $V_{CC}$ through a pullup resistor.
24	21	$V_{CC}$	Supply voltage

LOGIC DIAGRAM (POSITIVE LOGIC)

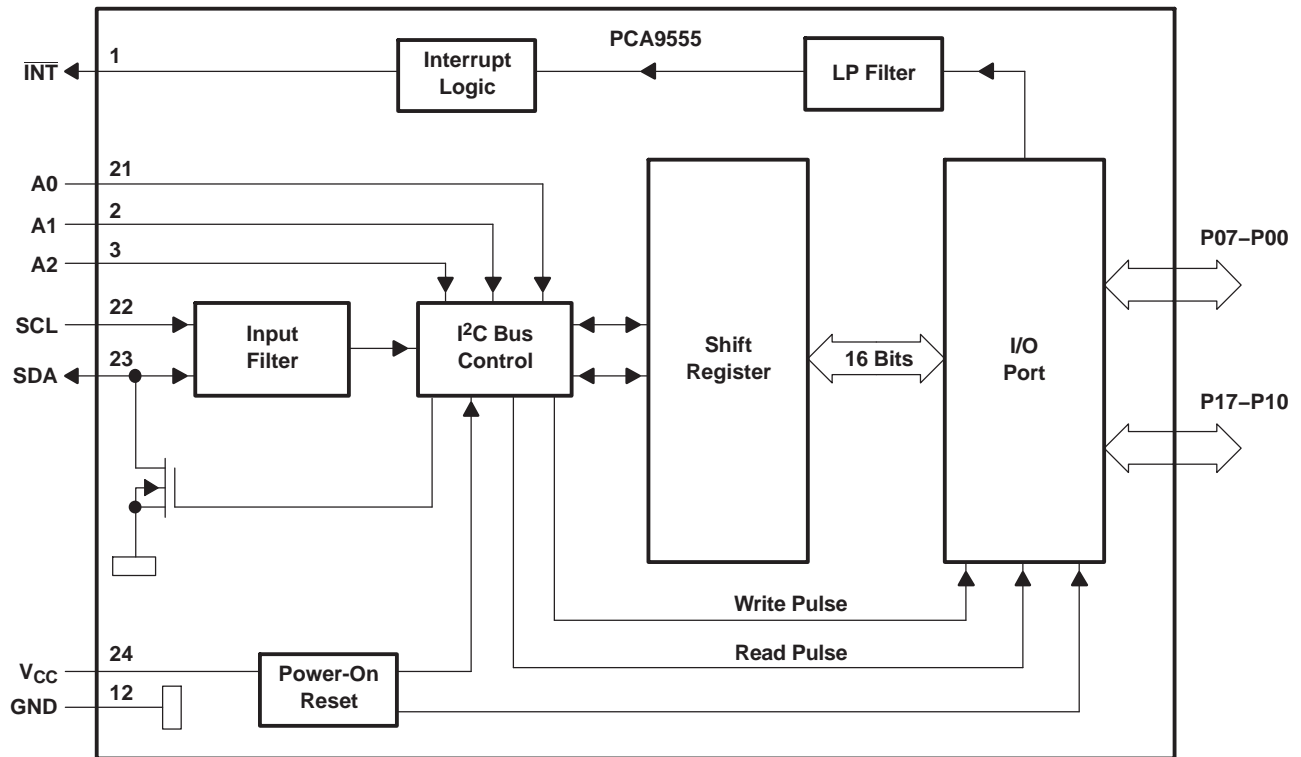

- A. Pin numbers shown are for DB, DBQ, DGV, DW, and PW packages.
- B. All I/Os are set to inputs at reset.

SIMPLIFIED SCHEMATIC OF P-PORT I/Os<sup>(1)</sup>

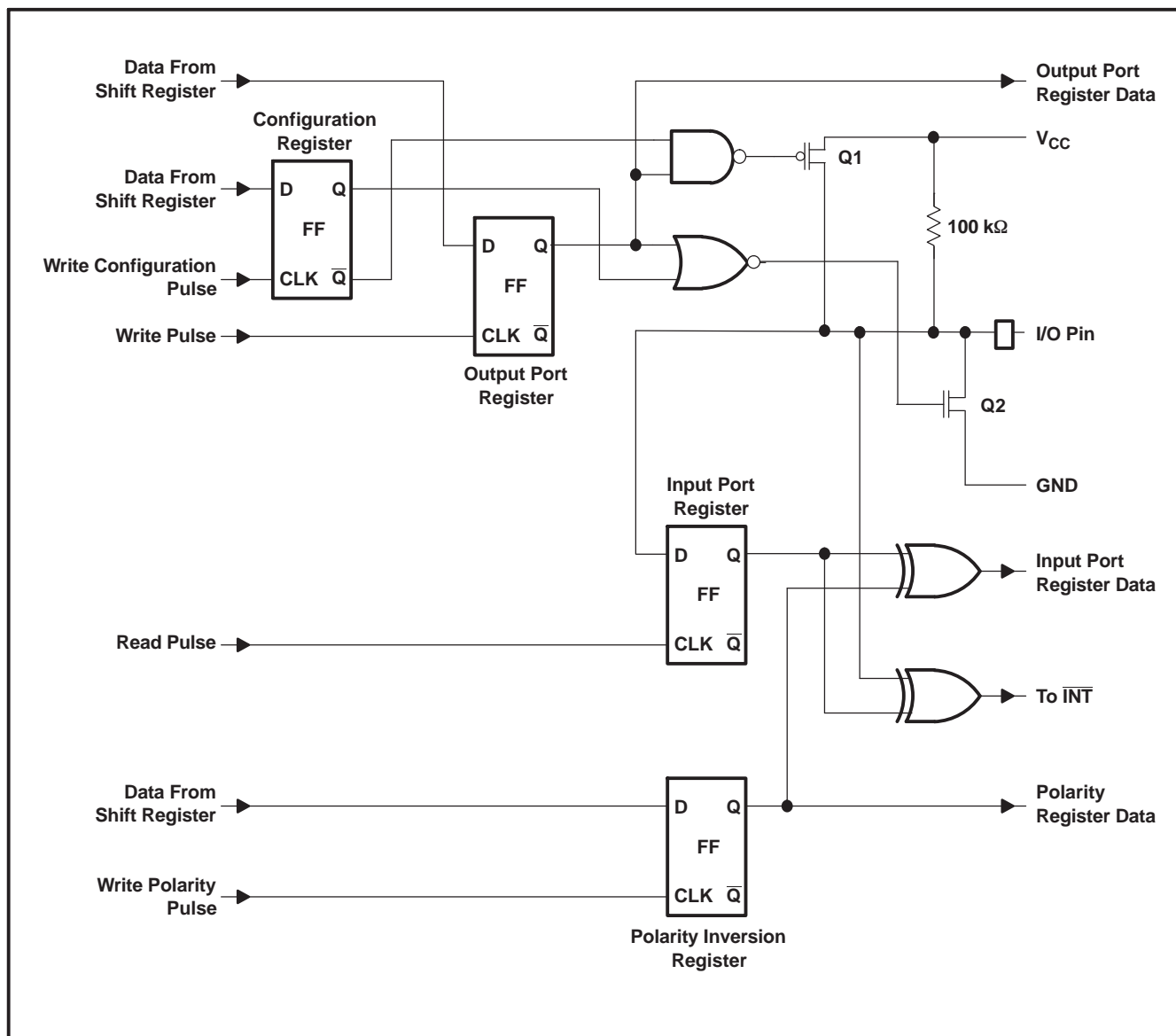

(1) At power-on reset, all registers return to default values.

I/O Port

When an I/O is configured as an input, FETs Q1 and Q2 are off, creating a high-impedance input. The input voltage may be raised above V<sub>CC</sub> to a maximum of 5.5 V.

If the I/O is configured as an output, Q1 or Q2 is enabled, depending on the state of the Output Port register. In this case, there are low-impedance paths between the I/O pin and either V<sub>CC</sub> or GND. The external voltage applied to this I/O pin should not exceed the recommended levels for proper operation.

## I<sup>2</sup>C Interface

The bidirectional I<sup>2</sup>C bus consists of the serial clock (SCL) and serial data (SDA) lines. Both lines must be connected to a positive supply via a pullup resistor when connected to the output stages of a device. Data transfer may be initiated only when the bus is not busy.

I<sup>2</sup>C communication with this device is initiated by a master sending a Start condition, a high-to-low transition on the SDA input/output while the SCL input is high (see Figure 1). After the Start condition, the device address byte is sent, MSB first, including the data direction bit (R/W). This device does not respond to the general call address.

After receiving the valid address byte, this device responds with an ACK, a low on the SDA input/output during the high of the ACK-related clock pulse. The address inputs (A0–A2) of the slave device must not be changed between the Start and Stop conditions.

On the I<sup>2</sup>C bus, only one data bit is transferred during each clock pulse. The data on the SDA line must remain stable during the high pulse of the clock period, as changes in the data line at this time are interpreted as control commands (Start or Stop) (see Figure 2).

A Stop condition, a low-to-high transition on the SDA input/output while the SCL input is high, is sent by the master (see Figure 1).

Any number of data bytes can be transferred from the transmitter to the receiver between the Start and the Stop conditions. Each byte of eight bits is followed by one ACK bit. The transmitter must release the SDA line before the receiver can send an ACK bit. The device that acknowledges must pull down the SDA line during the ACK clock pulse so that the SDA line is stable low during the high pulse of the ACK-related clock period (see Figure 3). When a slave receiver is addressed, it must generate an ACK after each byte is received. Similarly, the master must generate an ACK after each byte that it receives from the slave transmitter. Setup and hold times must be met to ensure proper operation.

A master receiver signals an end of data to the slave transmitter by not generating an acknowledge (NACK) after the last byte has been clocked out of the slave. This is done by the master receiver by holding the SDA line high. In this event, the transmitter must release the data line to enable the master to generate a Stop condition.

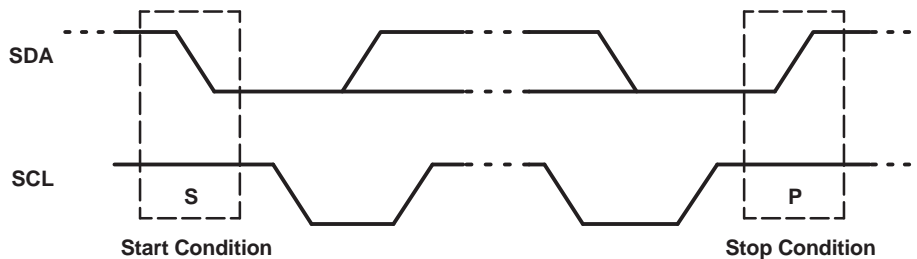

Figure 1. Definition of Start and Stop Conditions

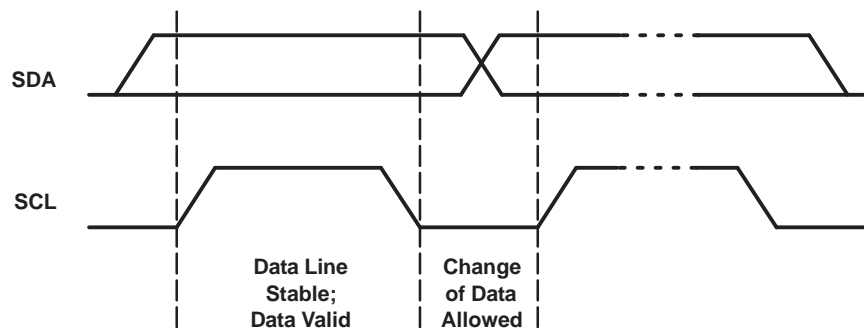

Figure 2. Bit Transfer

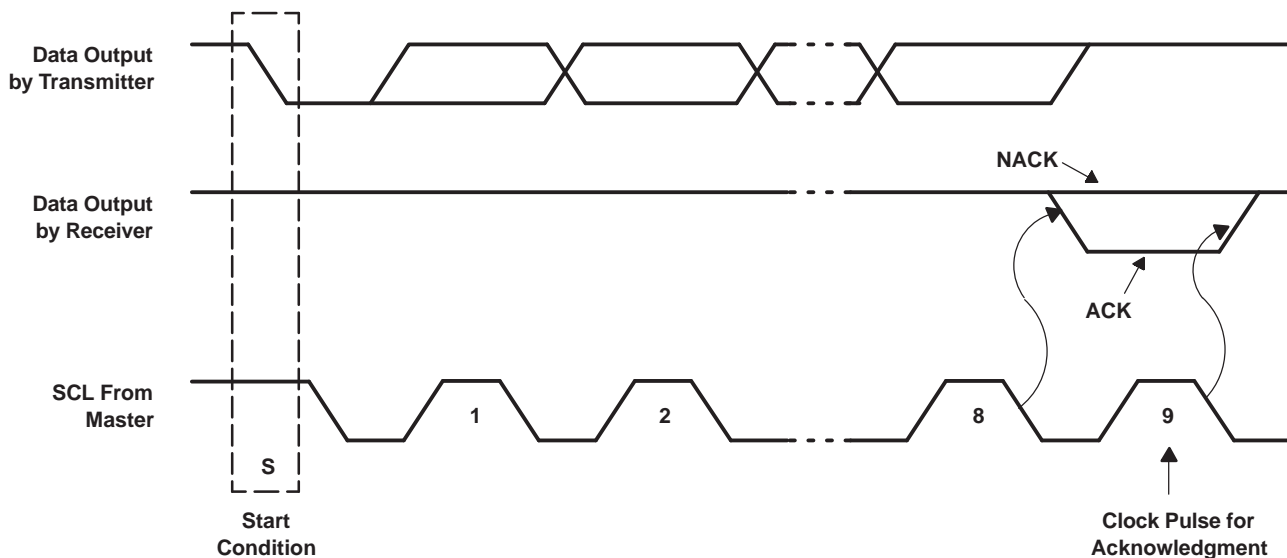

Figure 3. Acknowledgment on I<sup>2</sup>C Bus

Interface Definition

BYTE	BIT							
	7 (MSB)	6	5	4	3	2	1	0 (LSB)
I <sup>2</sup> C slave address	L	H	L	L	A2	A1	A0	R/W
P0x I/O data bus	P07	P06	P05	P04	P03	P02	P01	P00
P1x I/O data bus	P17	P16	P15	P14	P13	P12	P11	P10

## Device Address

Figure 4 shows the address byte of the PCA9555.

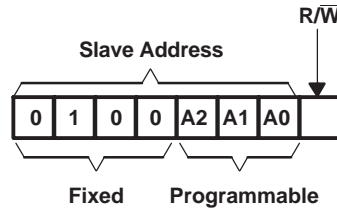

Figure 4. PCA9555 Address

### Address Reference

INPUTS			I <sup>2</sup> C BUS SLAVE ADDRESS
A2	A1	A0	
L	L	L	32 (decimal), 20 (hexadecimal)
L	L	H	33 (decimal), 21 (hexadecimal)
L	H	L	34 (decimal), 22 (hexadecimal)
L	H	H	35 (decimal), 23 (hexadecimal)
H	L	L	36 (decimal), 24 (hexadecimal)
H	L	H	37 (decimal), 25 (hexadecimal)
H	H	L	38 (decimal), 26 (hexadecimal)
H	H	H	39 (decimal), 27 (hexadecimal)

The last bit of the slave address defines the operation (read or write) to be performed. A high (1) selects a read operation, while a low (0) selects a write operation.

## Control Register and Command Byte

Following the successful acknowledgment of the address byte, the bus master sends a command byte that is stored in the control register in the PCA9555. Three bits of this data byte state the operation (read or write) and the internal register (input, output, polarity inversion, or configuration) that will be affected. This register can be written or read through the I<sup>2</sup>C bus. The command byte is sent only during a write transmission.

Once a command byte has been sent, the register that was addressed continues to be accessed by reads until a new command byte has been sent.

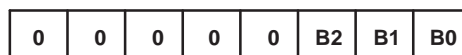

Figure 5. Control Register Bits

### Command Byte

CONTROL REGISTER BITS			COMMAND BYTE (HEX)	REGISTER	PROTOCOL	POWER-UP DEFAULT
B2	B1	B0				
0	0	0	0x00	Input Port 0	Read byte	xxxx xxxx
0	0	1	0x01	Input Port 1	Read byte	xxxx xxxx
0	1	0	0x02	Output Port 0	Read/write byte	1111 1111
0	1	1	0x03	Output Port 1	Read/write byte	1111 1111
1	0	0	0x04	Polarity Inversion Port 0	Read/write byte	0000 0000
1	0	1	0x05	Polarity Inversion Port 1	Read/write byte	0000 0000
1	1	0	0x06	Configuration Port 0	Read/write byte	1111 1111
1	1	1	0x07	Configuration Port 1	Read/write byte	1111 1111

## Register Descriptions

The Input Port registers (registers 0 and 1) reflect the incoming logic levels of the pins, regardless of whether the pin is defined as an input or an output by the Configuration register. It only acts on read operation. Writes to these registers have no effect. The default value, X, is determined by the externally applied logic level.

Before a read operation, a write transmission is sent with the command byte to indicate to the the I<sup>2</sup>C device that the Input Port register will be accessed next.

### Registers 0 and 1 (Input Port Registers)

<b>Bit</b>	<b>I0.7</b>	<b>I0.6</b>	<b>I0.5</b>	<b>I0.4</b>	<b>I0.3</b>	<b>I0.2</b>	<b>I0.1</b>	<b>I0.0</b>
<b>Default</b>	X	X	X	X	X	X	X	X
<b>Bit</b>	<b>I1.7</b>	<b>I1.6</b>	<b>I1.5</b>	<b>I1.4</b>	<b>I1.3</b>	<b>I1.2</b>	<b>I1.1</b>	<b>I1.0</b>
<b>Default</b>	X	X	X	X	X	X	X	X

The Output Port registers (registers 2 and 3) show the outgoing logic levels of the pins defined as outputs by the Configuration register. Bit values in this register have no effect on pins defined as inputs. In turn, reads from this register reflect the value that is in the flip-flop controlling the output selection, not the actual pin value.

### Registers 2 and 3 (Output Port Registers)

<b>Bit</b>	<b>O0.7</b>	<b>O0.6</b>	<b>O0.5</b>	<b>O0.4</b>	<b>O0.3</b>	<b>O0.2</b>	<b>O0.1</b>	<b>O0.0</b>
<b>Default</b>	1	1	1	1	1	1	1	1
<b>Bit</b>	<b>O1.7</b>	<b>O1.6</b>	<b>O1.5</b>	<b>O1.4</b>	<b>O1.3</b>	<b>O1.2</b>	<b>O1.1</b>	<b>O1.0</b>
<b>Default</b>	1	1	1	1	1	1	1	1

The Polarity Inversion registers (registers 4 and 5) allow polarity inversion of pins defined as inputs by the Configuration register. If a bit in this register is set (written with 1), the corresponding port pin's polarity is inverted. If a bit in this register is cleared (written with a 0), the corresponding port pin's original polarity is retained.

### Registers 4 and 5 (Polarity Inversion Registers)

<b>Bit</b>	<b>N0.7</b>	<b>N0.6</b>	<b>N0.5</b>	<b>N0.4</b>	<b>N0.3</b>	<b>N0.2</b>	<b>N0.1</b>	<b>N0.0</b>
<b>Default</b>	0	0	0	0	0	0	0	0
<b>Bit</b>	<b>N1.7</b>	<b>N1.6</b>	<b>N1.5</b>	<b>N1.4</b>	<b>N1.3</b>	<b>N1.2</b>	<b>N1.1</b>	<b>N1.0</b>
<b>Default</b>	0	0	0	0	0	0	0	0

The Configuration registers (registers 6 and 7) configure the directions of the I/O pins. If a bit in this register is set to 1, the corresponding port pin is enabled as an input with a high-impedance output driver. If a bit in this register is cleared to 0, the corresponding port pin is enabled as an output.

### Registers 6 and 7 (Configuration Registers)

<b>Bit</b>	<b>C0.7</b>	<b>C0.6</b>	<b>C0.5</b>	<b>C0.4</b>	<b>C0.3</b>	<b>C0.2</b>	<b>C0.1</b>	<b>C0.0</b>
<b>Default</b>	1	1	1	1	1	1	1	1
<b>Bit</b>	<b>C1.7</b>	<b>C1.6</b>	<b>C1.5</b>	<b>C1.4</b>	<b>C1.3</b>	<b>C1.2</b>	<b>C1.1</b>	<b>C1.0</b>
<b>Default</b>	1	1	1	1	1	1	1	1

## Power-On Reset

When power (from 0 V) is applied to V<sub>CC</sub>, an internal power-on reset holds the PCA9555 in a reset condition until V<sub>CC</sub> has reached V<sub>POR</sub>. At that point, the reset condition is released and the PCA9555 registers and I<sup>2</sup>C/SMBus state machine initialize to their default states. After that, V<sub>CC</sub> must be lowered to below 0.2 V and then back up to the operating voltage for a power-reset cycle.

## Interrupt ( $\overline{\text{INT}}$ ) Output

An interrupt is generated by any rising or falling edge of the port inputs in the input mode. After time,  $t_{iv}$ , the signal  $\overline{\text{INT}}$  is valid. Resetting the interrupt circuit is achieved when data on the port is changed to the original setting, data is read from the port that generated the interrupt or in a Stop event. Resetting occurs in the read mode at the acknowledge (ACK) bit or not acknowledge (NACK) bit after the falling edge of the SCL signal. Interrupts that occur during the ACK or NACK clock pulse can be lost (or be very short) due to the resetting of the interrupt during this pulse. Each change of the I/Os after resetting is detected and is transmitted as  $\overline{\text{INT}}$ .

Reading from or writing to another device does not affect the interrupt circuit, and a pin configured as an output cannot cause an interrupt. Changing an I/O from an output to an input may cause a false interrupt to occur if the state of the pin does not match the contents of the Input Port register. Because each 8-bit port is read independently, the interrupt caused by port 0 is not cleared by a read of port 1, or vice versa.

$\overline{\text{INT}}$  has an open-drain structure and requires a pullup resistor to  $V_{CC}$ .

## Bus Transactions

Data is exchanged between the master and the PCA9555 through write and read commands.

### Writes

Data is transmitted to the PCA9555 by sending the device address and setting the least-significant bit to a logic 0 (see Figure 4 for device address). The command byte is sent after the address and determines which register receives the data that follows the command byte.

The eight registers within the PCA9555 are configured to operate as four register pairs. The four pairs are input ports, output ports, polarity inversion ports, and configuration ports. After sending data to one register, the next data byte is sent to the other register in the pair (see Figure 6 and Figure 7). For example, if the first byte is sent to output port (register 3), the next byte is stored in Output Port 0 (register 2).

There is no limitation on the number of data bytes sent in one write transmission. In this way, each 8-bit register may be updated independently of the other registers.

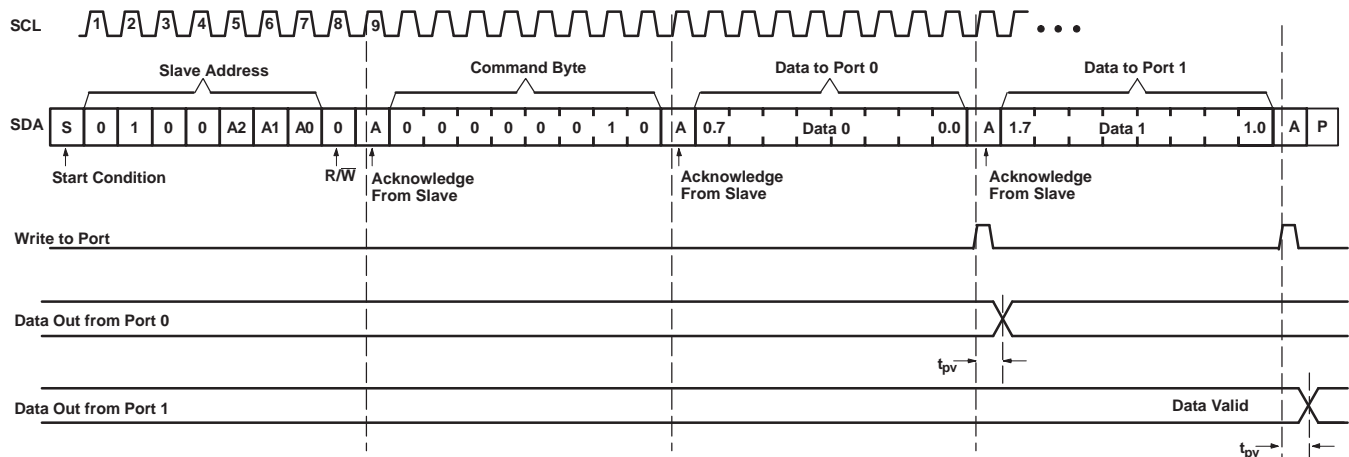

Figure 6. Write to Output Port Registers

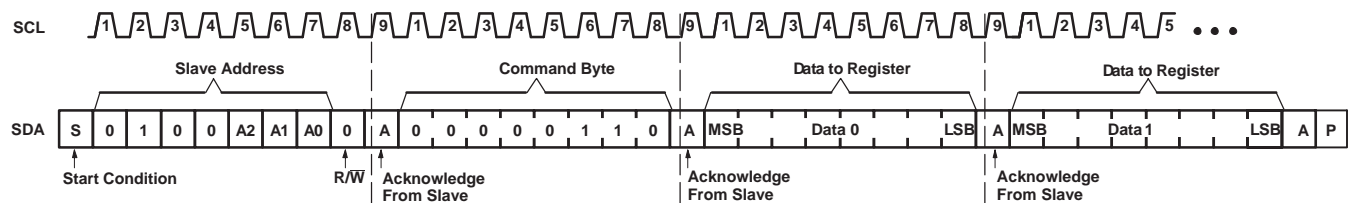

Figure 7. Write to Configuration Registers

Reads

The bus master first must send the PCA9555 address with the least-significant bit set to a logic 0 (see Figure 4 for device address). The command byte is sent after the address and determines which register is accessed. After a restart, the device address is sent again, but this time, the least-significant bit is set to a logic 1. Data from the register defined by the command byte then is sent by the PCA9555 (see Figure 8 through Figure 10).

After a restart, the value of the register defined by the command byte matches the register being accessed when the restart occurred. For example, if the command byte references Input Port 1 before the restart, and the restart occurs when Input Port 0 is being read, the stored command byte changes to reference Input Port 0. The original command byte is forgotten. If a subsequent restart occurs, Input Port 0 is read first. Data is clocked into the register on the rising edge of the ACK clock pulse. After the first byte is read, additional bytes may be read, but the data now reflect the information in the other register in the pair. For example, if Input Port 1 is read, the next byte read is Input Port 0.

Data is clocked into the register on the rising edge of the ACK clock pulse. There is no limitation on the number of data bytes received in one read transmission, but when the final byte is received, the bus master must not acknowledge the data.

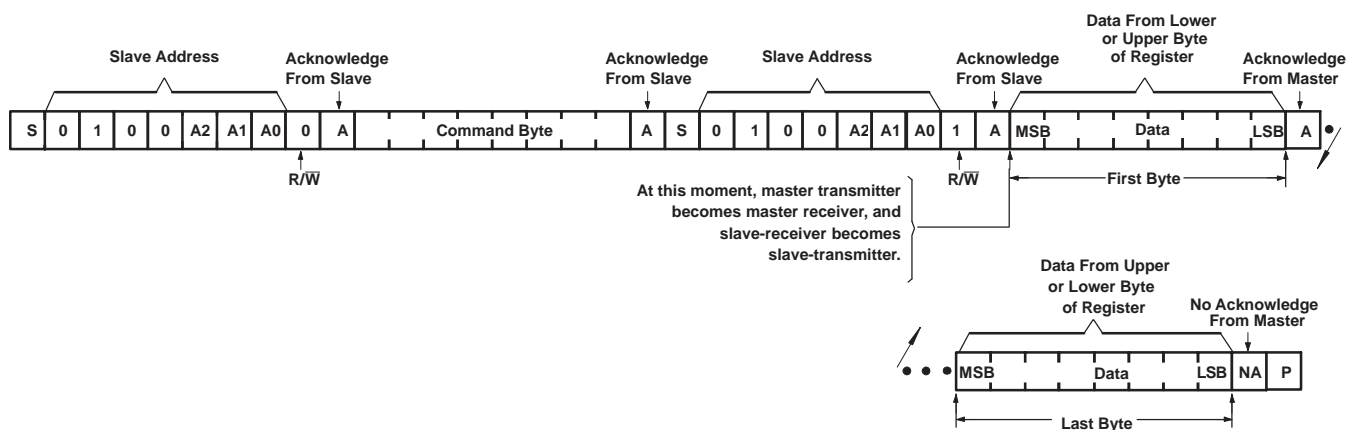
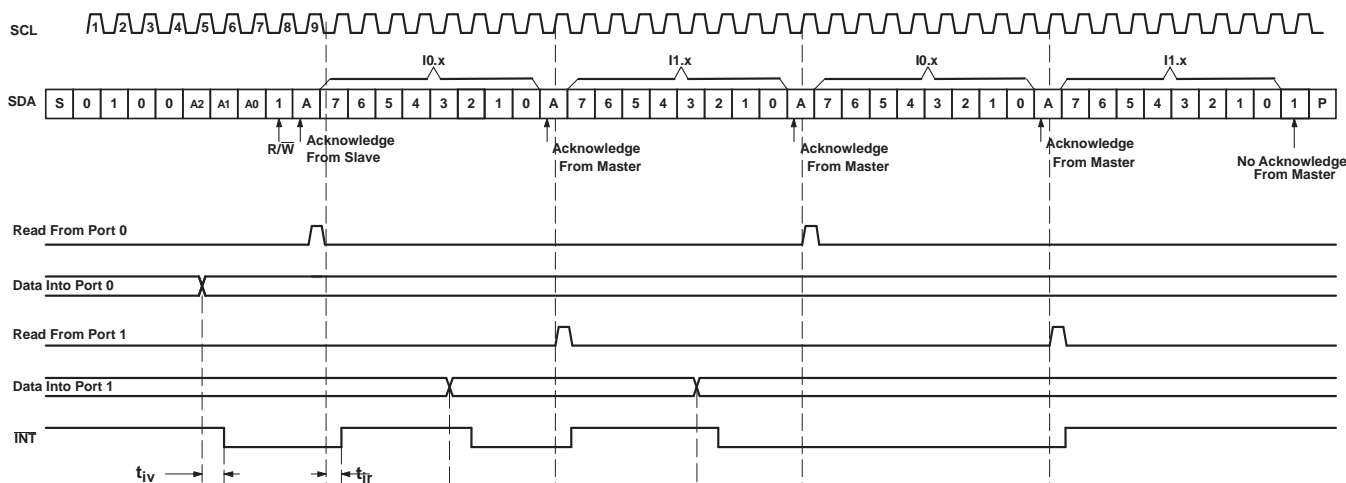
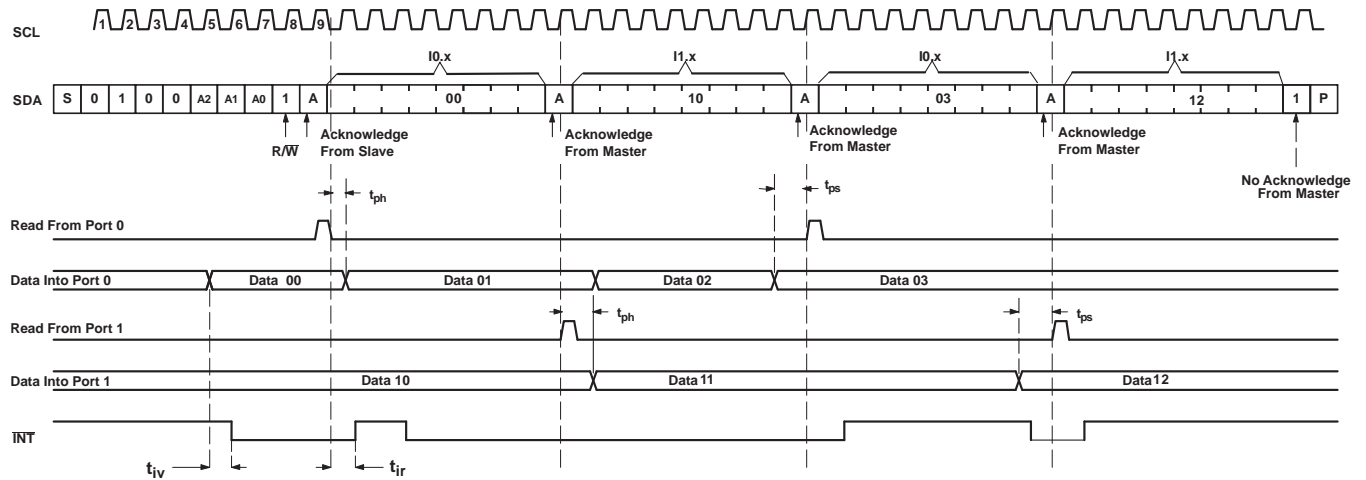

Figure 8. Read From Register



- A. Transfer of data can be stopped at any time by a Stop condition. When this occurs, data present at the latest acknowledge phase is valid (output mode). It is assumed that the command byte previously has been set to 00 (read Input Port register).
- B. This figure eliminates the command byte transfer, a restart, and slave address call between the initial slave address call and actual data transfer from the P port (see Figure 8 for these details).

Figure 9. Read Input Port Register, Scenario 1



- A. Transfer of data can be stopped at any time by a Stop condition. When this occurs, data present at the latest acknowledge phase is valid (output mode). It is assumed that the command byte previously has been set to 00 (read Input Port register).
- B. This figure eliminates the command byte transfer, a restart, and slave address call between the initial slave address call and actual data transfer from the P port (see [Figure 8](#) for these details).

**Figure 10. Read Input Port Register, Scenario 2**

## ABSOLUTE MAXIMUM RATINGS<sup>(1)</sup>

over operating free-air temperature range (unless otherwise noted)

		MIN	MAX	UNIT
V <sub>CC</sub>	Supply voltage range	–0.5	6	V
V <sub>I</sub>	Input voltage range <sup>(2)</sup>	–0.5	6	V
V <sub>O</sub>	Output voltage range <sup>(2)</sup>	–0.5	6	V
I <sub>IK</sub>	Input clamp current	V <sub>I</sub> < 0	–20	mA
I <sub>OK</sub>	Output clamp current	V <sub>O</sub> < 0	–20	mA
I <sub>IOK</sub>	Input/output clamp current	V <sub>O</sub> < 0 or V <sub>O</sub> > V <sub>CC</sub>	±20	mA
I <sub>OL</sub>	Continuous output low current	V <sub>O</sub> = 0 to V <sub>CC</sub>	50	mA
I <sub>OH</sub>	Continuous output high current	V <sub>O</sub> = 0 to V <sub>CC</sub>	–50	mA
I <sub>CC</sub>	Continuous current through GND		–250	mA
	Continuous current through V <sub>CC</sub>		160	
θ <sub>JA</sub>	Package thermal impedance, junction to free air <sup>(3)</sup>	DB package	63	°C/W
		DBQ package	61	
		DGV package	86	
		DW package	46	
		PW package	88	
		RGE package	45	
θ <sub>JP</sub>	Package thermal impedance, junction to pad	RGE package	1.5	°C/W
T <sub>stg</sub>	Storage temperature range	–65	150	°C

- (1) Stresses beyond those listed under *Absolute Maximum Ratings* may cause permanent damage to the device. These are stress ratings only, and functional operation of the device at these or any other conditions beyond those indicated under *Recommended Operating Conditions* is not implied. Exposure to absolute-maximum-rated conditions for extended periods may affect device reliability.
- (2) The input negative-voltage and output voltage ratings may be exceeded if the input and output current ratings are observed.
- (3) The package thermal impedance is calculated in accordance with JESD 51-7.

## RECOMMENDED OPERATING CONDITIONS

		MIN	MAX	UNIT	
V <sub>CC</sub>	Supply voltage	2.3	5.5	V	
V <sub>IH</sub>	High-level input voltage	SCL, SDA	0.7 × V <sub>CC</sub>	5.5	V
		A2–A0, P07–P00, P17–P10	0.7 × V <sub>CC</sub>	5.5	
V <sub>IL</sub>	Low-level input voltage	SCL, SDA	–0.5	0.3 × V <sub>CC</sub>	V
		A2–A0, P07–P00, P17–P10	–0.5	0.3 × V <sub>CC</sub>	
I <sub>OH</sub>	High-level output current	P07–P00, P17–P10	–10	mA	
I <sub>OL</sub>	Low-level output current	P07–P00, P17–P10	25	mA	
T <sub>A</sub>	Operating free-air temperature	–40	85	°C	

## ELECTRICAL CHARACTERISTICS

over recommended operating free-air temperature range (unless otherwise noted)

PARAMETER		TEST CONDITIONS	V <sub>CC</sub>	MIN	TYP <sup>(1)</sup>	MAX	UNIT	
V <sub>IK</sub>	Input diode clamp voltage	I <sub>I</sub> = -18 mA	2.3 V to 5.5 V	-1.2			V	
V <sub>POR</sub>	Power-on reset voltage	V <sub>I</sub> = V <sub>CC</sub> or GND, I <sub>O</sub> = 0	V <sub>POR</sub>		1.5	1.65	V	
V <sub>OH</sub>	P-port high-level output voltage <sup>(2)</sup>	I <sub>OH</sub> = -8 mA	2.3 V		1.8		V	
			3 V		2.6			
			4.75 V		4.1			
		I <sub>OH</sub> = -10 mA	2.3 V		1.7			
			3 V		2.5			
			4.75 V		4			
I <sub>OL</sub>	SDA	V <sub>OL</sub> = 0.4 V	2.3 V to 5.5 V			3	mA	
	P port <sup>(3)</sup>	V <sub>OL</sub> = 0.5 V			8	20		
		V <sub>OL</sub> = 0.7 V			10	24		
	INT	V <sub>OL</sub> = 0.4 V				3		
I <sub>I</sub>	SCL, SDA	V <sub>I</sub> = V <sub>CC</sub> or GND	2.3 V to 5.5 V			±1	μA	
	A2–A0					±1		
I <sub>IH</sub>	P port	V <sub>I</sub> = V <sub>CC</sub>	2.3 V to 5.5 V			1	μA	
I <sub>IL</sub>	P port	V <sub>I</sub> = GND	2.3 V to 5.5 V			-100	μA	
I <sub>CC</sub>	Operating mode	V <sub>I</sub> = V <sub>CC</sub> or GND, I <sub>O</sub> = 0, I/O = inputs, f <sub>SCL</sub> = 400 kHz, No load	5.5 V		100	200	μA	
			3.6 V		30	75		
			2.7 V		20	50		
	Standby mode	Low inputs	V <sub>I</sub> = GND, I <sub>O</sub> = 0, I/O = inputs, f <sub>SCL</sub> = 0 kHz, No load	5.5 V		1.1	1.5	mA
				3.6 V		0.7	1.3	
		High inputs	V <sub>I</sub> = V <sub>CC</sub> , I <sub>O</sub> = 0, I/O = inputs, f <sub>SCL</sub> = 0 kHz, No load	5.5 V		0.5	1	μA
				3.6 V		0.4	0.9	
				2.7 V		0.25	0.8	
ΔI <sub>CC</sub>	Additional current in standby mode	One input at V <sub>CC</sub> - 0.6 V, Other inputs at V <sub>CC</sub> or GND	2.3 V to 5.5 V			1.5	mA	
C <sub>I</sub>	SCL	V <sub>I</sub> = V <sub>CC</sub> or GND	2.3 V to 5.5 V		3	7	pF	
C <sub>io</sub>	SDA	V <sub>IO</sub> = V <sub>CC</sub> or GND	2.3 V to 5.5 V		3	7	pF	
	P port				3.7	9.5		

(1) All typical values are at nominal supply voltage (2.5-V, 3.3-V, or 5-V V<sub>CC</sub>) and T<sub>A</sub> = 25°C.

(2) Each I/O must be externally limited to a maximum of 25 mA, and each octal (P07–P00 and P17–P10) must be limited to a maximum current of 100 mA, for a device total of 200 mA.

(3) The total current sourced by all I/Os must be limited to 160 mA (80 mA for P07–P00 and 80 mA for P17–P10).

## I<sup>2</sup>C INTERFACE TIMING REQUIREMENTS

over recommended operating free-air temperature range (unless otherwise noted) (see [Figure 11](#))

		MIN	MAX	UNIT	
$f_{scl}$	I <sup>2</sup> C clock frequency	0	400	kHz	
$t_{sch}$	I <sup>2</sup> C clock high time	0.6		μs	
$t_{scl}$	I <sup>2</sup> C clock low time	1.3		μs	
$t_{sp}$	I <sup>2</sup> C spike time		50	ns	
$t_{sds}$	I <sup>2</sup> C serial-data setup time	100		ns	
$t_{sdh}$	I <sup>2</sup> C serial-data hold time	0		ns	
$t_{icr}$	I <sup>2</sup> C input rise time	$20 + 0.1C_b^{(1)}$	300	ns	
$t_{icf}$	I <sup>2</sup> C input fall time	$20 + 0.1C_b^{(1)}$	300	ns	
$t_{ocf}$	I <sup>2</sup> C output fall time	10-pF to 400-pF bus	$20 + 0.1C_b^{(1)}$	300	ns
$t_{buf}$	I <sup>2</sup> C bus free time between Stop and Start	1.3		μs	
$t_{sts}$	I <sup>2</sup> C Start or repeated Start condition setup	0.6		μs	
$t_{sth}$	I <sup>2</sup> C Start or repeated Start condition hold	0.6		μs	
$t_{sps}$	I <sup>2</sup> C Stop condition setup	0.6		μs	
$t_{vd(Data)}$	Valid-data time	SCL low to SDA output valid	50	ns	
$t_{vd(ack)}$	Valid-data time of ACK condition	ACK signal from SCL low to SDA (out) low	0.1	0.9	μs
$C_b$	I <sup>2</sup> C bus capacitive load		400	pF	

(1)  $C_b$  = total capacitance of one bus line in pF

## SWITCHING CHARACTERISTICS

over recommended operating free-air temperature range,  $C_L \leq 100$  pF (unless otherwise noted) (see [Figure 12](#) and [Figure 13](#))

PARAMETER	FROM (INPUT)	TO (OUTPUT)	MIN	MAX	UNIT
$t_{iv}$	Interrupt valid time	P port		4	μs
$t_{ir}$	Interrupt reset delay time	SCL		4	μs
$t_{pv}$	Output data valid	SCL		200	ns
$t_{ps}$	Input data setup time	P port	150		ns
$t_{ph}$	Input data hold time	P port	1		μs

**TYPICAL CHARACTERISTICS**

$T_A = 25^\circ\text{C}$  (unless otherwise noted)

**SUPPLY CURRENT  
VS  
TEMPERATURE**

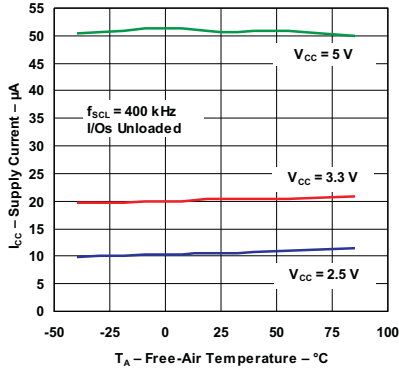

**STANDBY SUPPLY CURRENT  
VS  
TEMPERATURE**

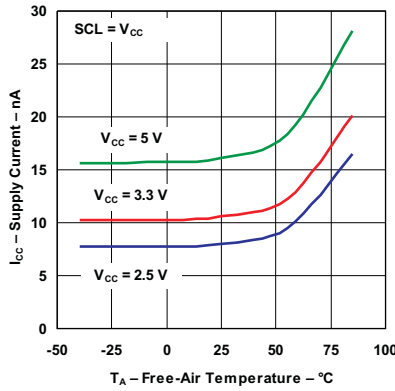

**SUPPLY CURRENT  
VS  
SUPPLY VOLTAGE**

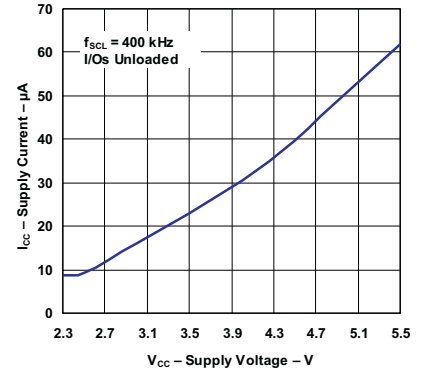

**I/O SINK CURRENT  
VS  
OUTPUT LOW VOLTAGE**

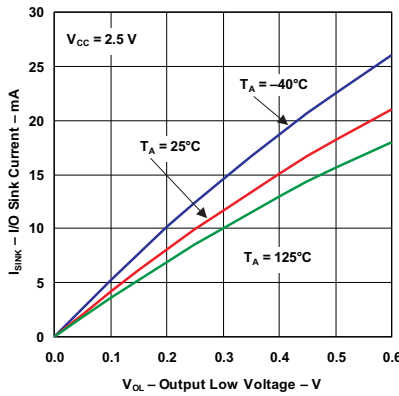

**I/O SINK CURRENT  
VS  
OUTPUT LOW VOLTAGE**

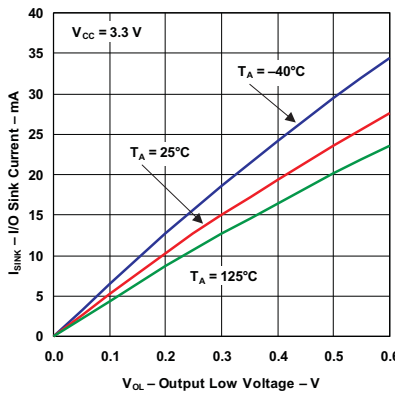

**I/O SINK CURRENT  
VS  
OUTPUT LOW VOLTAGE**

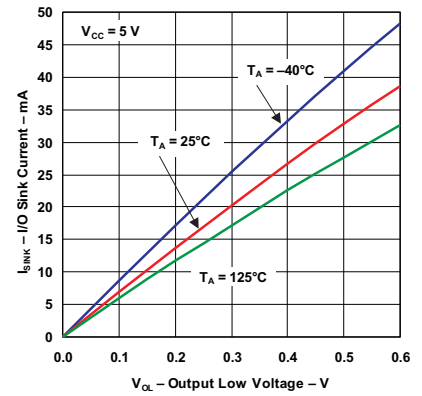

**I/O OUTPUT LOW VOLTAGE  
VS  
TEMPERATURE**

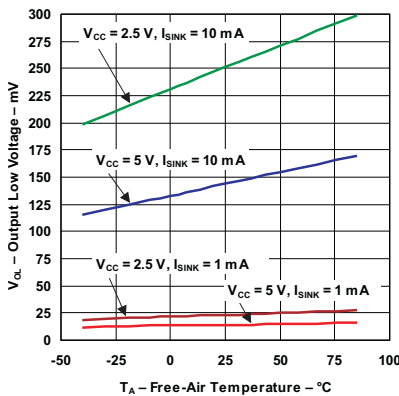

**I/O SOURCE CURRENT  
VS  
OUTPUT HIGH VOLTAGE**

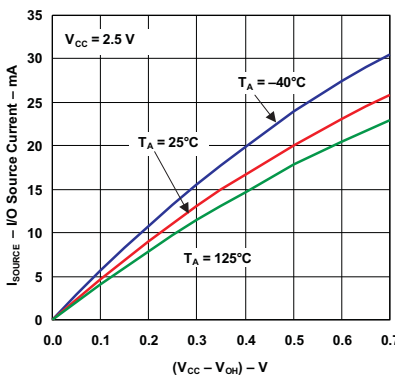

**I/O SOURCE CURRENT  
VS  
OUTPUT HIGH VOLTAGE**

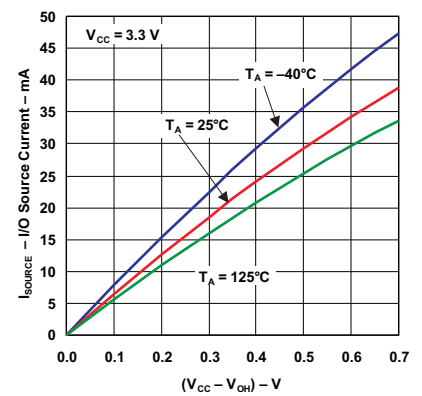

TYPICAL CHARACTERISTICS (continued)

T<sub>A</sub> = 25°C (unless otherwise noted)

I/O SOURCE CURRENT VS OUTPUT HIGH VOLTAGE

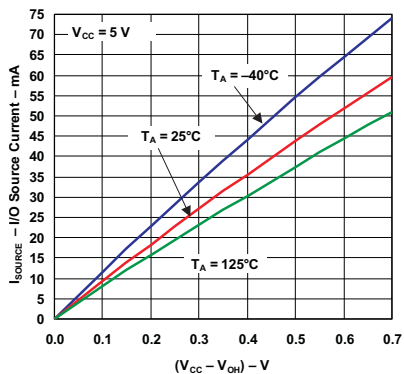

I/O HIGH VOLTAGE VS TEMPERATURE

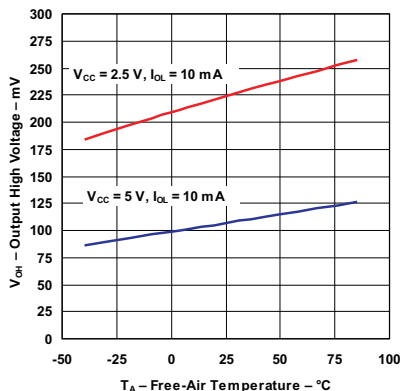

SUPPLY CURRENT VS NUMBER OF I/Os HELD LOW

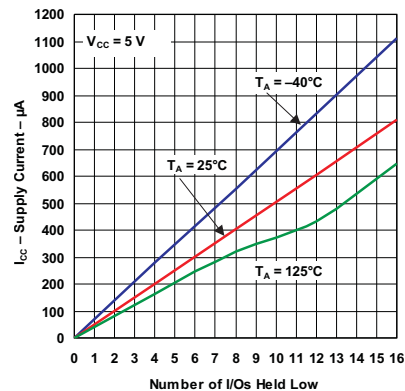

OUTPUT HIGH VOLTAGE VS SUPPLY VOLTAGE

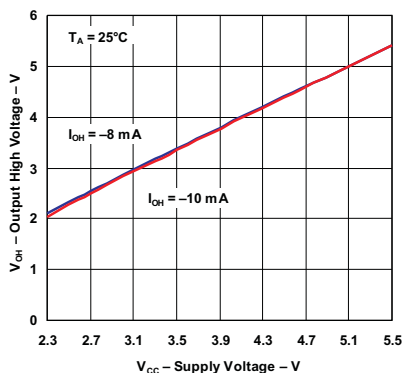



PARAMETER MEASUREMENT INFORMATION (continued)

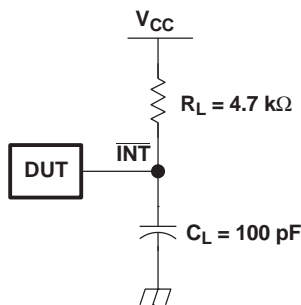

INTERRUPT LOAD CONFIGURATION

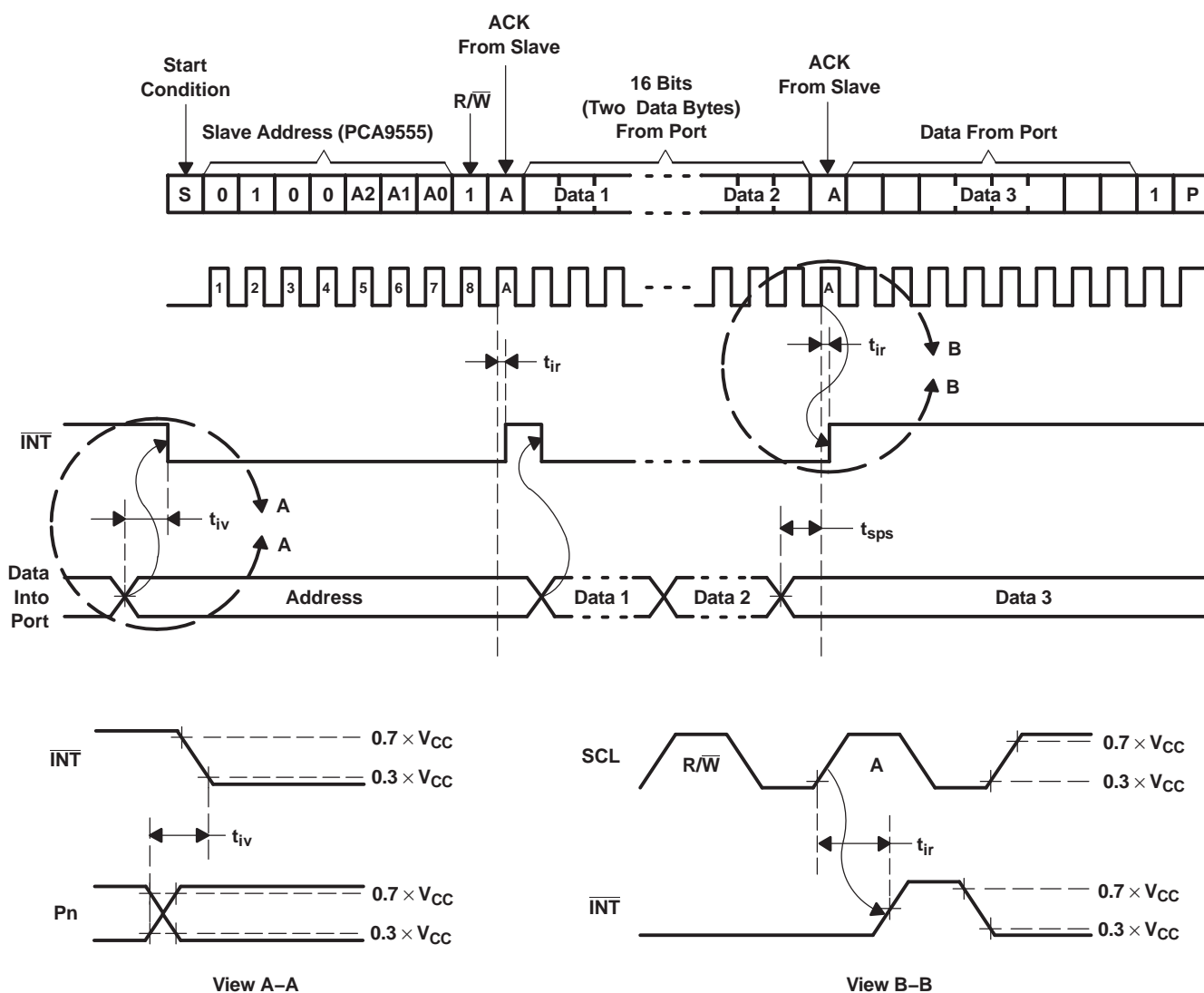

- A. C<sub>L</sub> includes probe and jig capacitance.
- B. All inputs are supplied by generators having the following characteristics: PRR ≤ 10 MHz, Z<sub>O</sub> = 50 Ω, t<sub>r</sub>/t<sub>f</sub> ≤ 30 ns.
- C. All parameters and waveforms are not applicable to all devices.

Figure 12. Interrupt Load Circuit and Voltage Waveforms

### PARAMETER MEASUREMENT INFORMATION (continued)

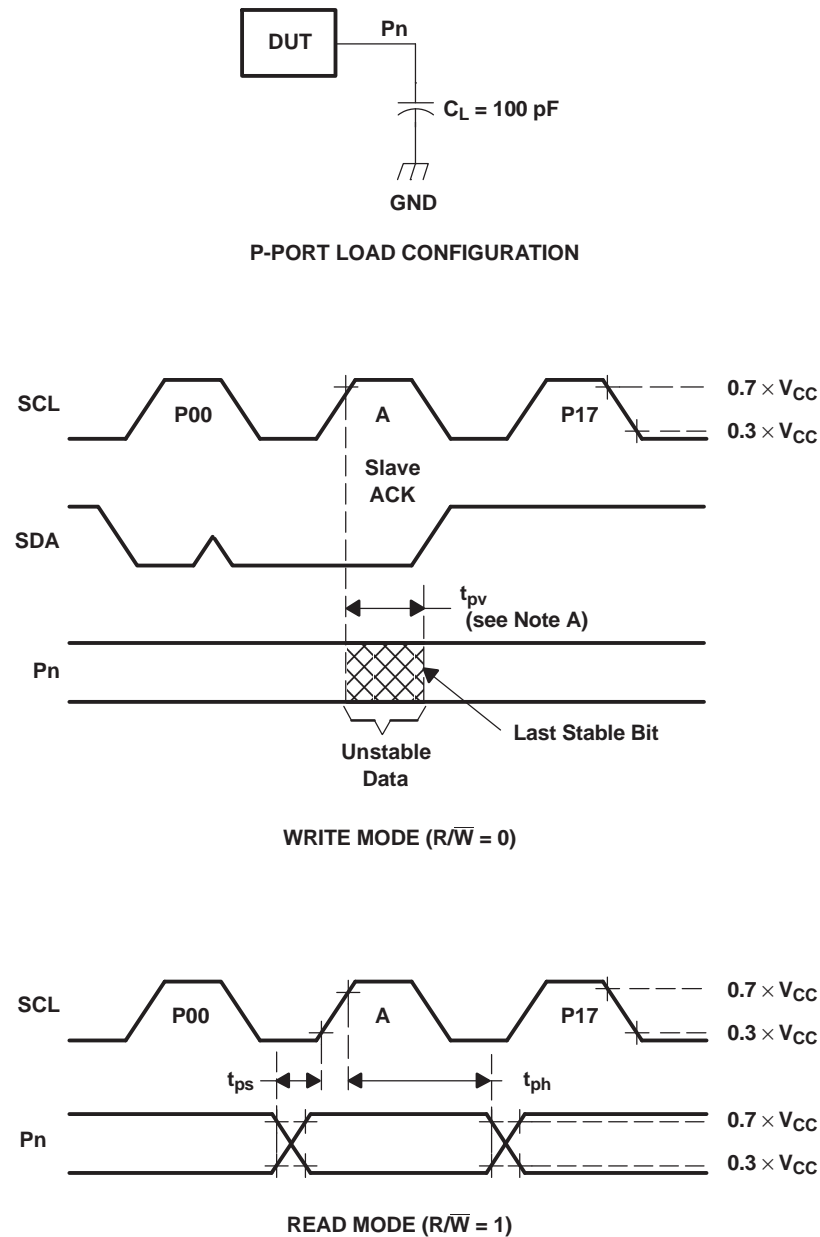

- A.  $C_L$  includes probe and jig capacitance.
- B.  $t_{pv}$  is measured from  $0.7 \times V_{CC}$  on SCL to 50% I/O (Pn) output.
- C. All inputs are supplied by generators having the following characteristics: PRR  $\leq$  10 MHz,  $Z_O = 50 \Omega$ ,  $t_r/t_f \leq 30$  ns.
- D. The outputs are measured one at a time, with one transition per measurement.
- E. All parameters and waveforms are not applicable to all devices.

**Figure 13. P-Port Load Circuit and Voltage Waveforms**

PARAMETER MEASUREMENT INFORMATION (continued)

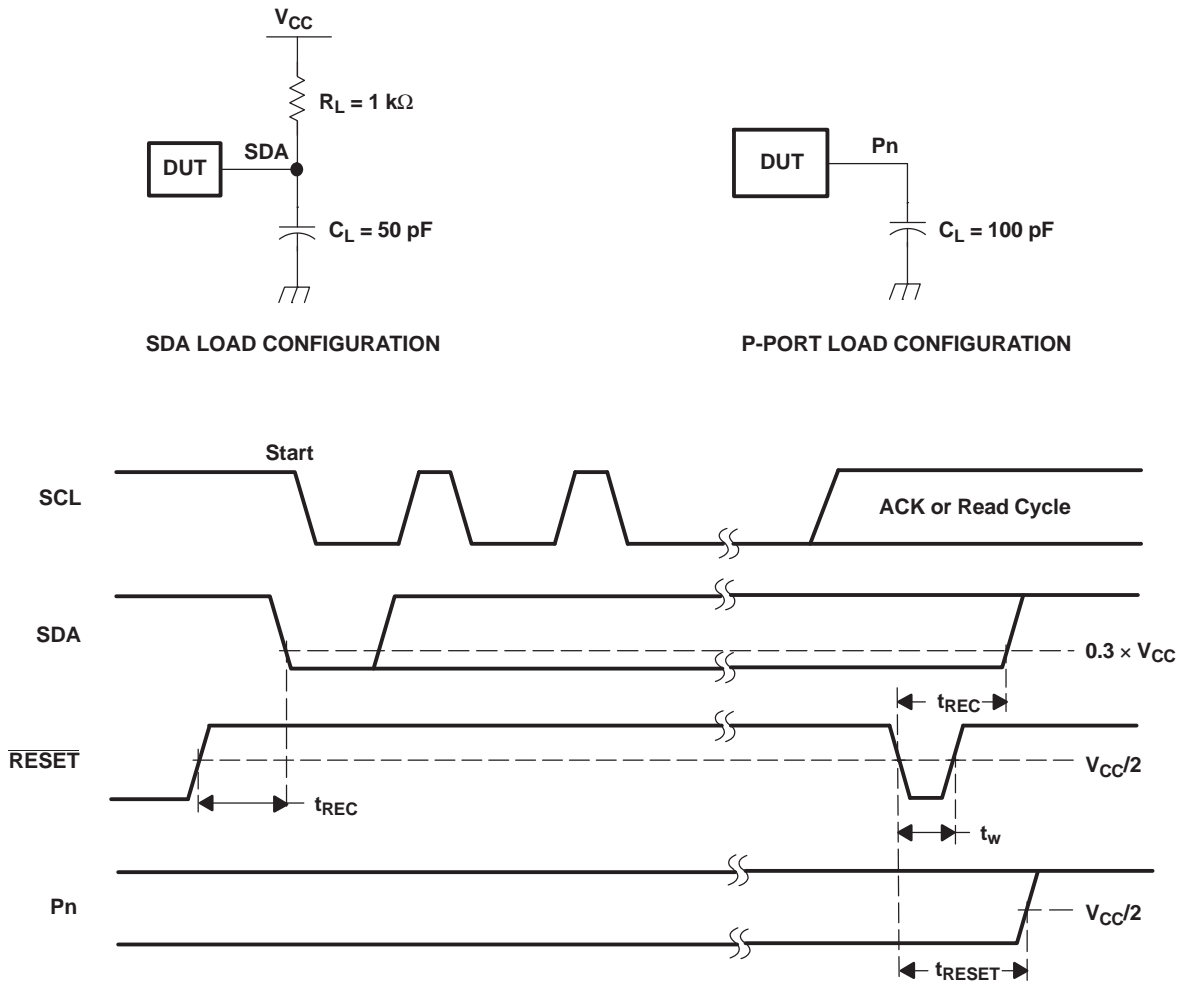

- A.  $C_L$  includes probe and jig capacitance.
- B. All inputs are supplied by generators having the following characteristics:  $PRR \leq 10$  MHz,  $Z_O = 50 \Omega$ ,  $t_r/t_f \leq 30$  ns.
- C. The outputs are measured one at a time, with one transition per measurement.
- D. I/Os are configured as inputs.
- E. All parameters and waveforms are not applicable to all devices.

Figure 14. Reset Load Circuits and Voltage Waveforms

## APPLICATION INFORMATION

Figure 15 shows an application in which the PCA9555 can be used.

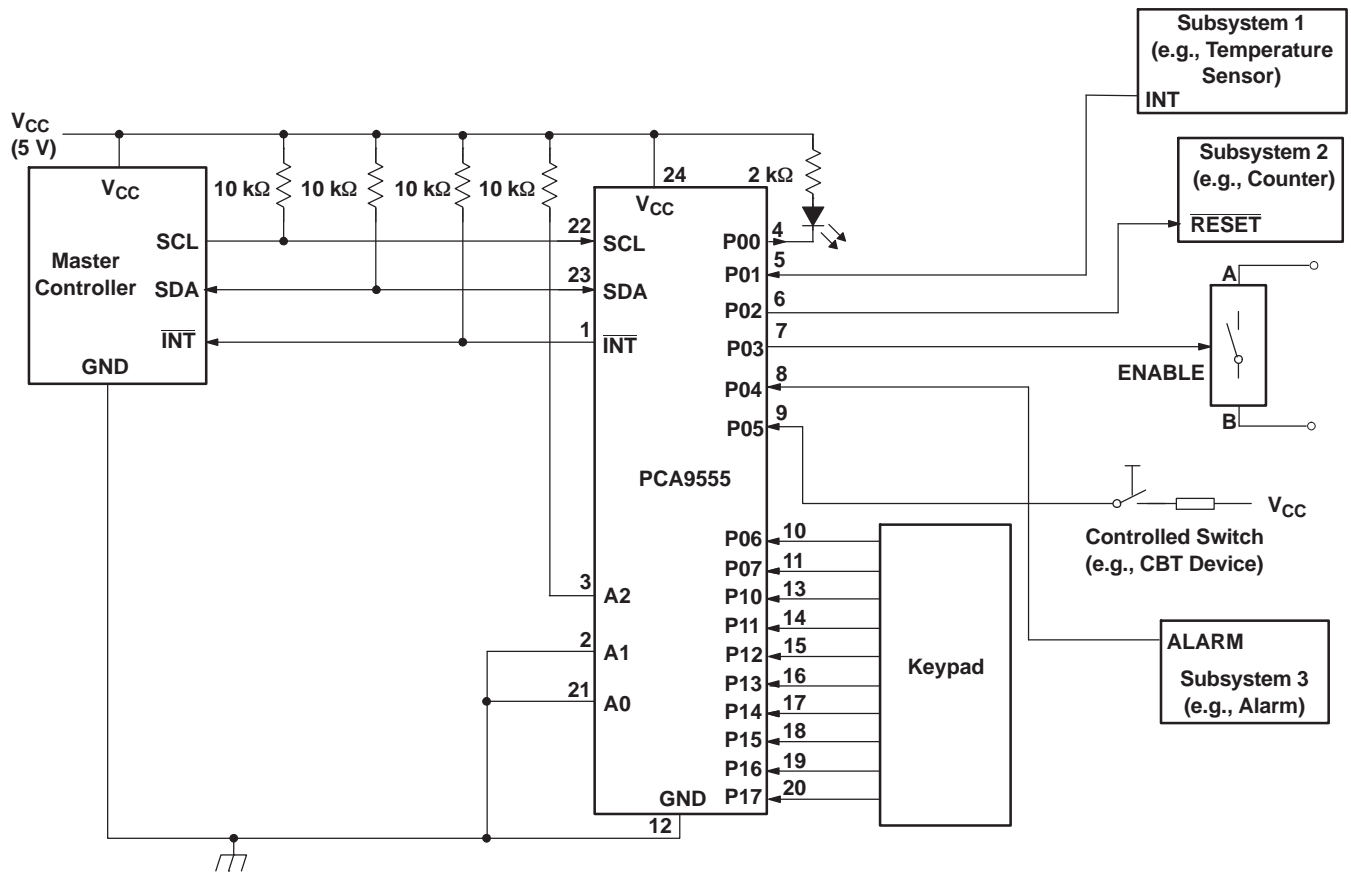

- Device address is configured as 0100100 for this example.
- P00, P02, and P03 are configured as outputs.
- P01, P04–P07, and P10–P17 are configured as inputs.
- Pin numbers shown are for DB, DBQ, DGV, DW, and PW packages.

**Figure 15. Typical Application**

### Minimizing $I_{CC}$ When I/O Is Used to Control LED

When an I/O is used to control an LED, normally it is connected to  $V_{CC}$  through a resistor as shown in Figure 15. Because the LED acts as a diode, when the LED is off, the I/O  $V_{IN}$  is about 1.2 V less than  $V_{CC}$ . The  $\Delta I_{CC}$  parameter in Electrical Characteristics shows how  $I_{CC}$  increases as  $V_{IN}$  becomes lower than  $V_{CC}$ . For battery-powered applications, it is essential that the voltage of I/O pins is greater than or equal to  $V_{CC}$  when the LED is off to minimize current consumption.

Figure 16 shows a high-value resistor in parallel with the LED. Figure 17 shows  $V_{CC}$  less than the LED supply voltage by at least 1.2 V. Both of these methods maintain the I/O  $V_{IN}$  at or above  $V_{CC}$  and prevent additional supply current consumption when the LED is off.

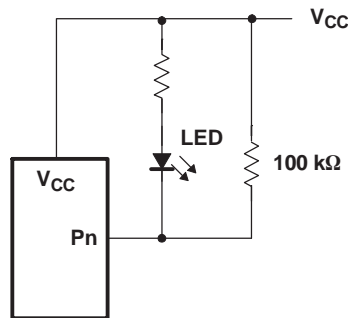

**Figure 16. High-Value Resistor in Parallel With LED**

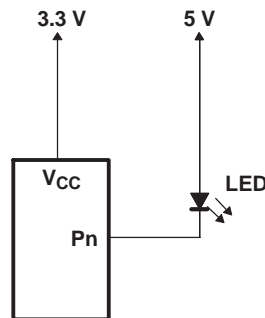

**Figure 17. Device Supplied by Lower Voltage**

**PACKAGING INFORMATION**

Orderable Device	Status <sup>(1)</sup>	Package Type	Package Drawing	Pins	Package Qty	Eco Plan <sup>(2)</sup>	Lead/ Ball Finish	MSL Peak Temp <sup>(3)</sup>	Samples (Requires Login)
PCA9555DB	NRND	SSOP	DB	24	60	Green (RoHS & no Sb/Br)	CU NIPDAU	Level-1-260C-UNLIM	
PCA9555DBG4	NRND	SSOP	DB	24	60	Green (RoHS & no Sb/Br)	CU NIPDAU	Level-1-260C-UNLIM	
PCA9555DBQ	NRND	SSOP	DBQ	24		TBD	Call TI	Call TI	
PCA9555DBQR	NRND	SSOP	DBQ	24	2500	Green (RoHS & no Sb/Br)	CU NIPDAU	Level-2-260C-1 YEAR	
PCA9555DBQRG4	NRND	SSOP	DBQ	24	2500	Green (RoHS & no Sb/Br)	CU NIPDAU	Level-2-260C-1 YEAR	
PCA9555DBR	NRND	SSOP	DB	24	2000	Green (RoHS & no Sb/Br)	CU NIPDAU	Level-1-260C-UNLIM	
PCA9555DBRG4	NRND	SSOP	DB	24	2000	Green (RoHS & no Sb/Br)	CU NIPDAU	Level-1-260C-UNLIM	
PCA9555DGVR	NRND	TVSOP	DGV	24	2000	Green (RoHS & no Sb/Br)	CU NIPDAU	Level-1-260C-UNLIM	
PCA9555DGVRG4	NRND	TVSOP	DGV	24	2000	Green (RoHS & no Sb/Br)	CU NIPDAU	Level-1-260C-UNLIM	
PCA9555DW	NRND	SOIC	DW	24	25	Green (RoHS & no Sb/Br)	CU NIPDAU	Level-1-260C-UNLIM	
PCA9555DWG4	NRND	SOIC	DW	24	25	Green (RoHS & no Sb/Br)	CU NIPDAU	Level-1-260C-UNLIM	
PCA9555DWR	NRND	SOIC	DW	24	2000	Green (RoHS & no Sb/Br)	CU NIPDAU	Level-1-260C-UNLIM	
PCA9555DWRG4	NRND	SOIC	DW	24	2000	Green (RoHS & no Sb/Br)	CU NIPDAU	Level-1-260C-UNLIM	
PCA9555DWT	NRND	SOIC	DW	24		TBD	Call TI	Call TI	
PCA9555N	NRND	PDIP	N	24		TBD	Call TI	Call TI	
PCA9555PW	NRND	TSSOP	PW	24	60	Green (RoHS & no Sb/Br)	CU NIPDAU	Level-1-260C-UNLIM	
PCA9555PWE4	NRND	TSSOP	PW	24	60	Green (RoHS & no Sb/Br)	CU NIPDAU	Level-1-260C-UNLIM	
PCA9555PWG4	NRND	TSSOP	PW	24	60	Green (RoHS & no Sb/Br)	CU NIPDAU	Level-1-260C-UNLIM	

Orderable Device	Status <sup>(1)</sup>	Package Type	Package Drawing	Pins	Package Qty	Eco Plan <sup>(2)</sup>	Lead/ Ball Finish	MSL Peak Temp <sup>(3)</sup>	Samples (Requires Login)
PCA9555PWR	NRND	TSSOP	PW	24	2000	Green (RoHS & no Sb/Br)	CU NIPDAU	Level-1-260C-UNLIM	
PCA9555PWRE4	NRND	TSSOP	PW	24	2000	Green (RoHS & no Sb/Br)	CU NIPDAU	Level-1-260C-UNLIM	
PCA9555PWRG4	NRND	TSSOP	PW	24	2000	Green (RoHS & no Sb/Br)	CU NIPDAU	Level-1-260C-UNLIM	
PCA9555PWT	NRND	TSSOP	PW	24		TBD	Call TI	Call TI	
PCA9555RGER	NRND	VQFN	RGE	24	3000	Green (RoHS & no Sb/Br)	CU NIPDAU	Level-2-260C-1 YEAR	
PCA9555RGERG4	NRND	VQFN	RGE	24	3000	Green (RoHS & no Sb/Br)	CU NIPDAU	Level-2-260C-1 YEAR	
PCA9555RHLLR	NRND	QFN	RHL	24		TBD	Call TI	Call TI	

<sup>(1)</sup> The marketing status values are defined as follows:

**ACTIVE:** Product device recommended for new designs.

**LIFEBUY:** TI has announced that the device will be discontinued, and a lifetime-buy period is in effect.

**NRND:** Not recommended for new designs. Device is in production to support existing customers, but TI does not recommend using this part in a new design.

**PREVIEW:** Device has been announced but is not in production. Samples may or may not be available.

**OBSELETE:** TI has discontinued the production of the device.

<sup>(2)</sup> Eco Plan - The planned eco-friendly classification: Pb-Free (RoHS), Pb-Free (RoHS Exempt), or Green (RoHS & no Sb/Br) - please check <http://www.ti.com/productcontent> for the latest availability information and additional product content details.

**TBD:** The Pb-Free/Green conversion plan has not been defined.

**Pb-Free (RoHS):** TI's terms "Lead-Free" or "Pb-Free" mean semiconductor products that are compatible with the current RoHS requirements for all 6 substances, including the requirement that lead not exceed 0.1% by weight in homogeneous materials. Where designed to be soldered at high temperatures, TI Pb-Free products are suitable for use in specified lead-free processes.

**Pb-Free (RoHS Exempt):** This component has a RoHS exemption for either 1) lead-based flip-chip solder bumps used between the die and package, or 2) lead-based die adhesive used between the die and leadframe. The component is otherwise considered Pb-Free (RoHS compatible) as defined above.

**Green (RoHS & no Sb/Br):** TI defines "Green" to mean Pb-Free (RoHS compatible), and free of Bromine (Br) and Antimony (Sb) based flame retardants (Br or Sb do not exceed 0.1% by weight in homogeneous material)

<sup>(3)</sup> MSL, Peak Temp. -- The Moisture Sensitivity Level rating according to the JEDEC industry standard classifications, and peak solder temperature.

**Important Information and Disclaimer:** The information provided on this page represents TI's knowledge and belief as of the date that it is provided. TI bases its knowledge and belief on information provided by third parties, and makes no representation or warranty as to the accuracy of such information. Efforts are underway to better integrate information from third parties. TI has taken and continues to take reasonable steps to provide representative and accurate information but may not have conducted destructive testing or chemical analysis on incoming materials and chemicals. TI and TI suppliers consider certain information to be proprietary, and thus CAS numbers and other limited information may not be available for release.

In no event shall TI's liability arising out of such information exceed the total purchase price of the TI part(s) at issue in this document sold by TI to Customer on an annual basis.

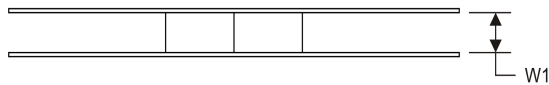
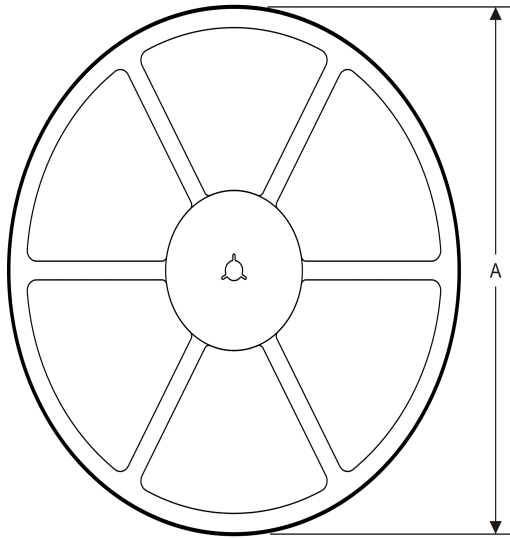
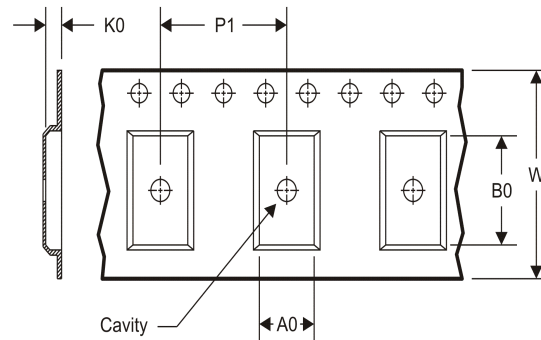

**TAPE AND REEL INFORMATION**
**REEL DIMENSIONS**

**TAPE DIMENSIONS**

A0	Dimension designed to accommodate the component width
B0	Dimension designed to accommodate the component length
K0	Dimension designed to accommodate the component thickness
W	Overall width of the carrier tape
P1	Pitch between successive cavity centers

**TAPE AND REEL INFORMATION**

\*All dimensions are nominal

Device	Package Type	Package Drawing	Pins	SPQ	Reel Diameter (mm)	Reel Width W1 (mm)	A0 (mm)	B0 (mm)	K0 (mm)	P1 (mm)	W (mm)	Pin1 Quadrant
PCA9555DBQR	SSOP	DBQ	24	2500	330.0	16.4	6.5	9.0	2.1	8.0	16.0	Q1
PCA9555DBR	SSOP	DB	24	2000	330.0	16.4	8.2	8.8	2.5	12.0	16.0	Q1
PCA9555DGVR	TVSOP	DGV	24	2000	330.0	12.4	6.9	5.6	1.6	8.0	12.0	Q1
PCA9555DWR	SOIC	DW	24	2000	330.0	24.4	10.75	15.7	2.7	12.0	24.0	Q1
PCA9555PWR	TSSOP	PW	24	2000	330.0	16.4	6.95	8.3	1.6	8.0	16.0	Q1

**TAPE AND REEL BOX DIMENSIONS**

\*All dimensions are nominal

Device	Package Type	Package Drawing	Pins	SPQ	Length (mm)	Width (mm)	Height (mm)
PCA9555DBQR	SSOP	DBQ	24	2500	367.0	367.0	38.0
PCA9555DBR	SSOP	DB	24	2000	367.0	367.0	38.0
PCA9555DGVR	TVSOP	DGV	24	2000	367.0	367.0	35.0
PCA9555DWR	SOIC	DW	24	2000	367.0	367.0	45.0
PCA9555PWR	TSSOP	PW	24	2000	367.0	367.0	38.0

N (R-PDIP-T24)

PLASTIC DUAL-IN-LINE

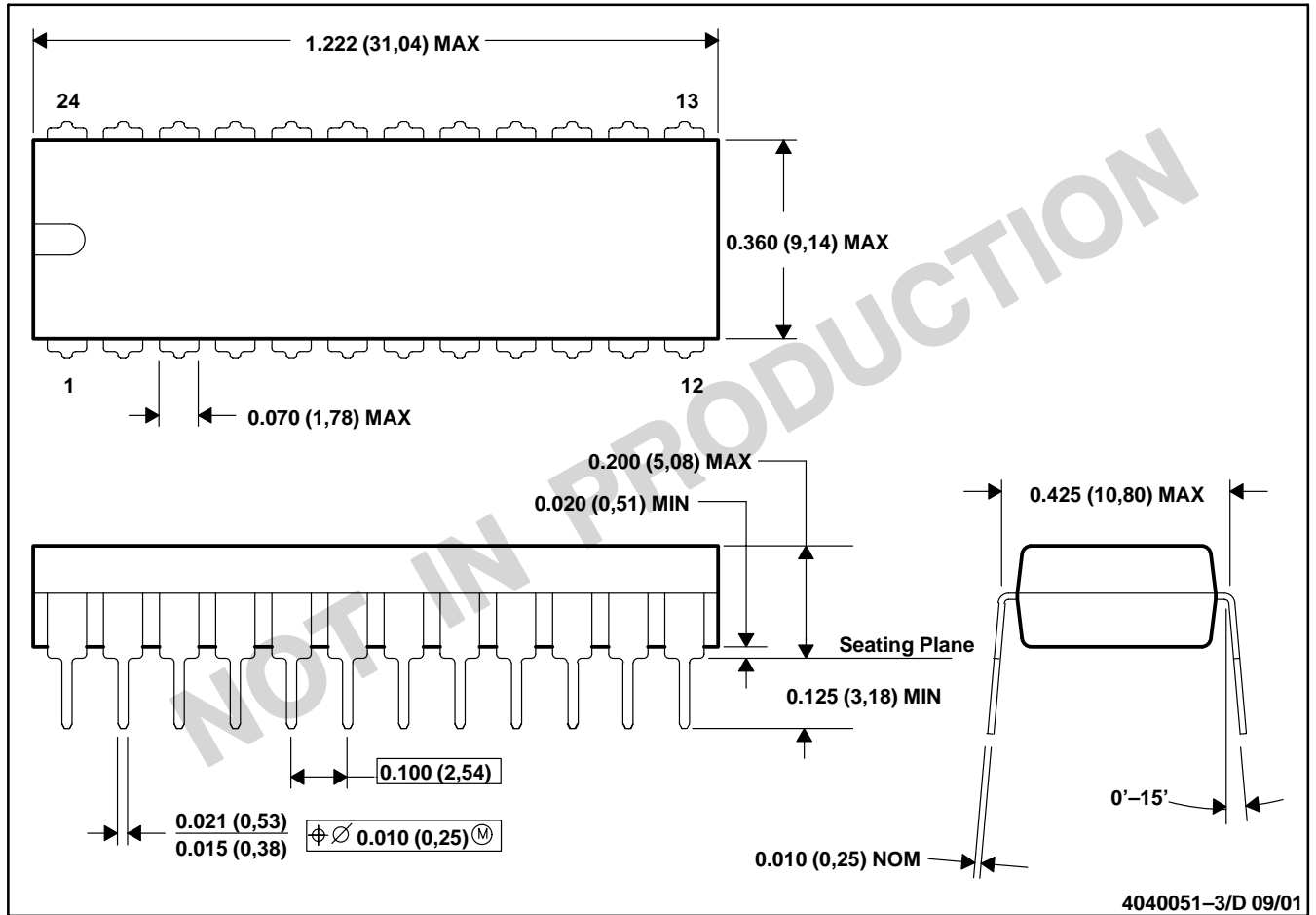

- NOTES: A. All linear dimensions are in inches (millimeters).  
 B. This drawing is subject to change without notice.  
 C. Falls within JEDEC MS-010

DW (R-PDSO-G24)

PLASTIC SMALL OUTLINE

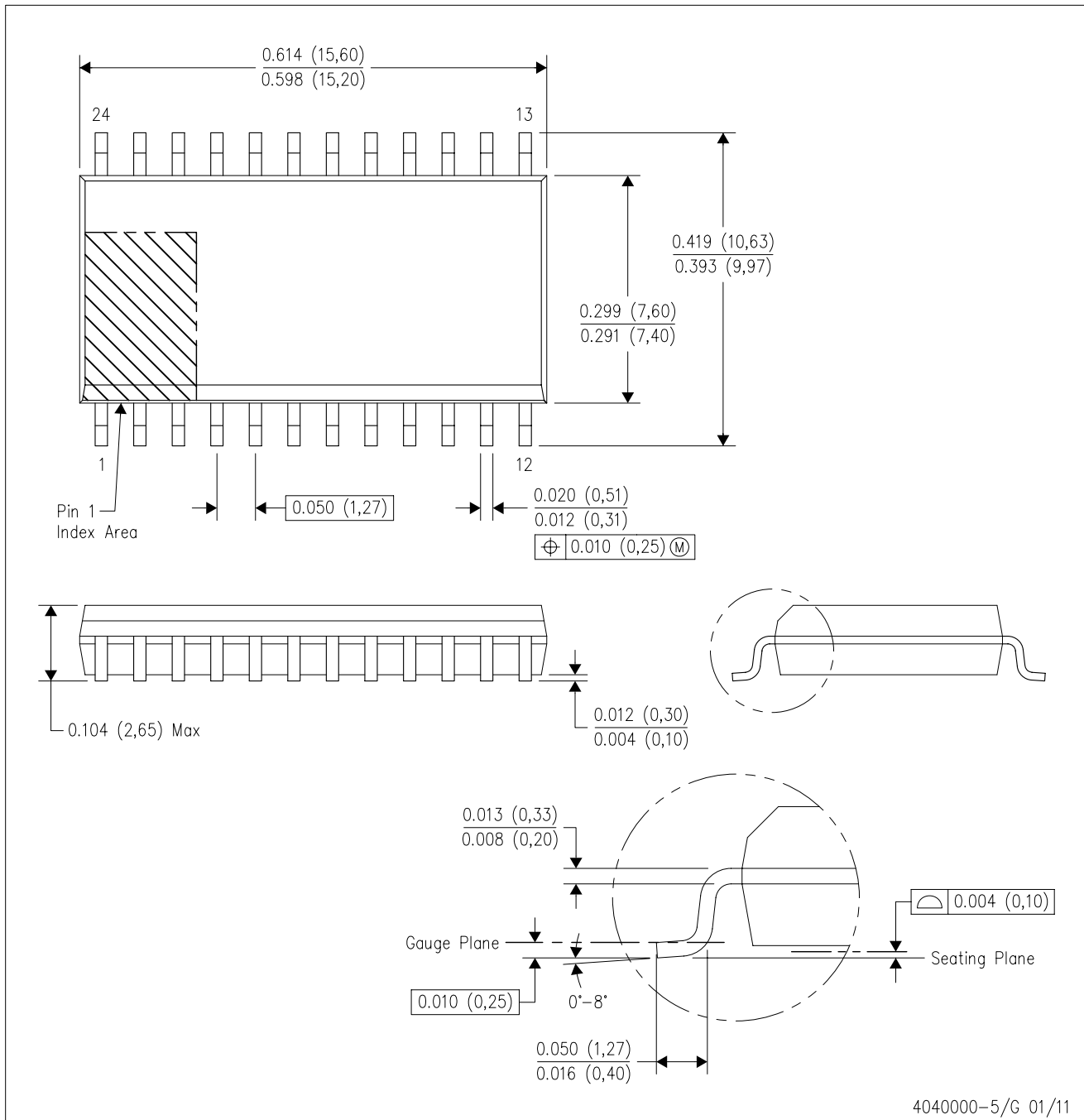

- NOTES:
- A. All linear dimensions are in inches (millimeters). Dimensioning and tolerancing per ASME Y14.5M-1994.
  - B. This drawing is subject to change without notice.
  - C. Body dimensions do not include mold flash or protrusion not to exceed 0.006 (0,15).
  - D. Falls within JEDEC MS-013 variation AD.

DBQ (R-PDSO-G24)

PLASTIC SMALL-OUTLINE PACKAGE

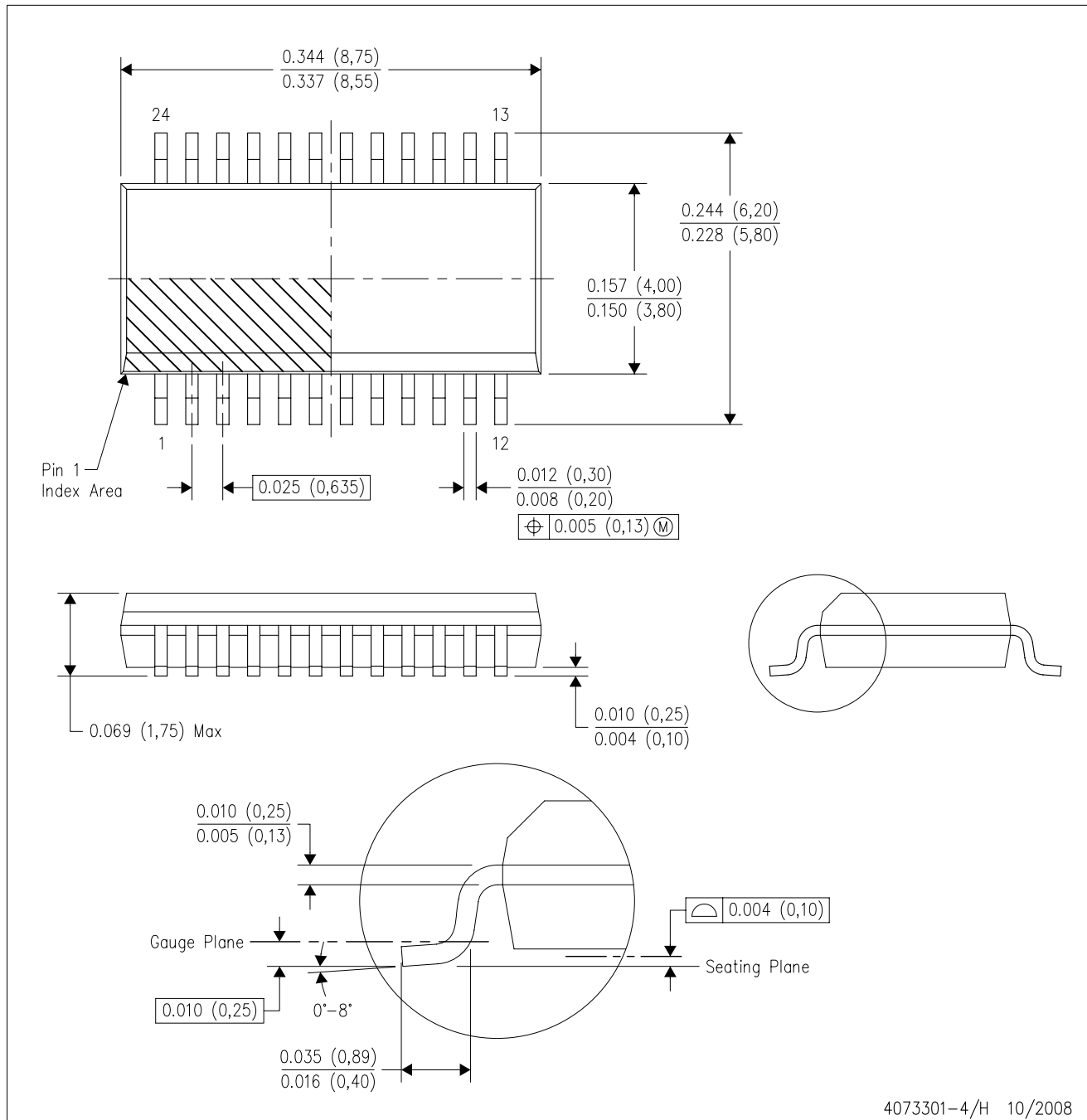

- NOTES:
- A. All linear dimensions are in inches (millimeters).
  - B. This drawing is subject to change without notice.
  - C. Body dimensions do not include mold flash or protrusion not to exceed 0.006 (0,15) per side.
  - D. Falls within JEDEC MO-137 variation AE.

DBQ (R-PDSO-G24)

PLASTIC SMALL OUTLINE PACKAGE

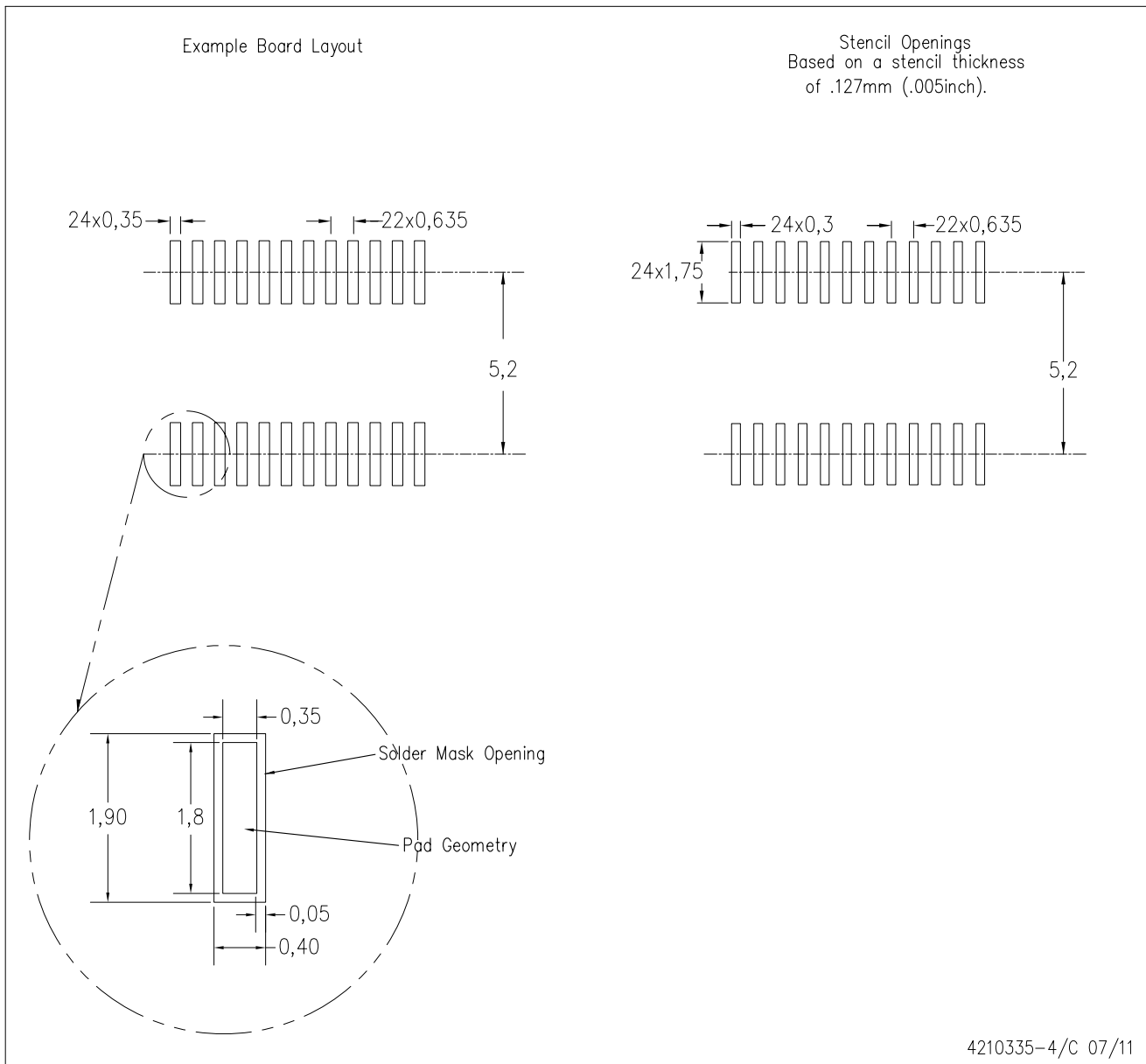



- NOTES:
- A. All linear dimensions are in millimeters.
  - B. This drawing is subject to change without notice.
  - C. Customers should place a note on the circuit board fabrication drawing not to alter the center solder mask defined pad.
  - D. Publication IPC-7351 is recommended for alternate designs.
  - E. Laser cutting apertures with trapezoidal walls and also rounding corners will offer better paste release. Customers should contact their board assembly site for stencil design recommendations. Example stencil design based on a 50% volumetric metal load solder paste. Refer to IPC-7525 for other stencil recommendations.

PW (R-PDSO-G24)

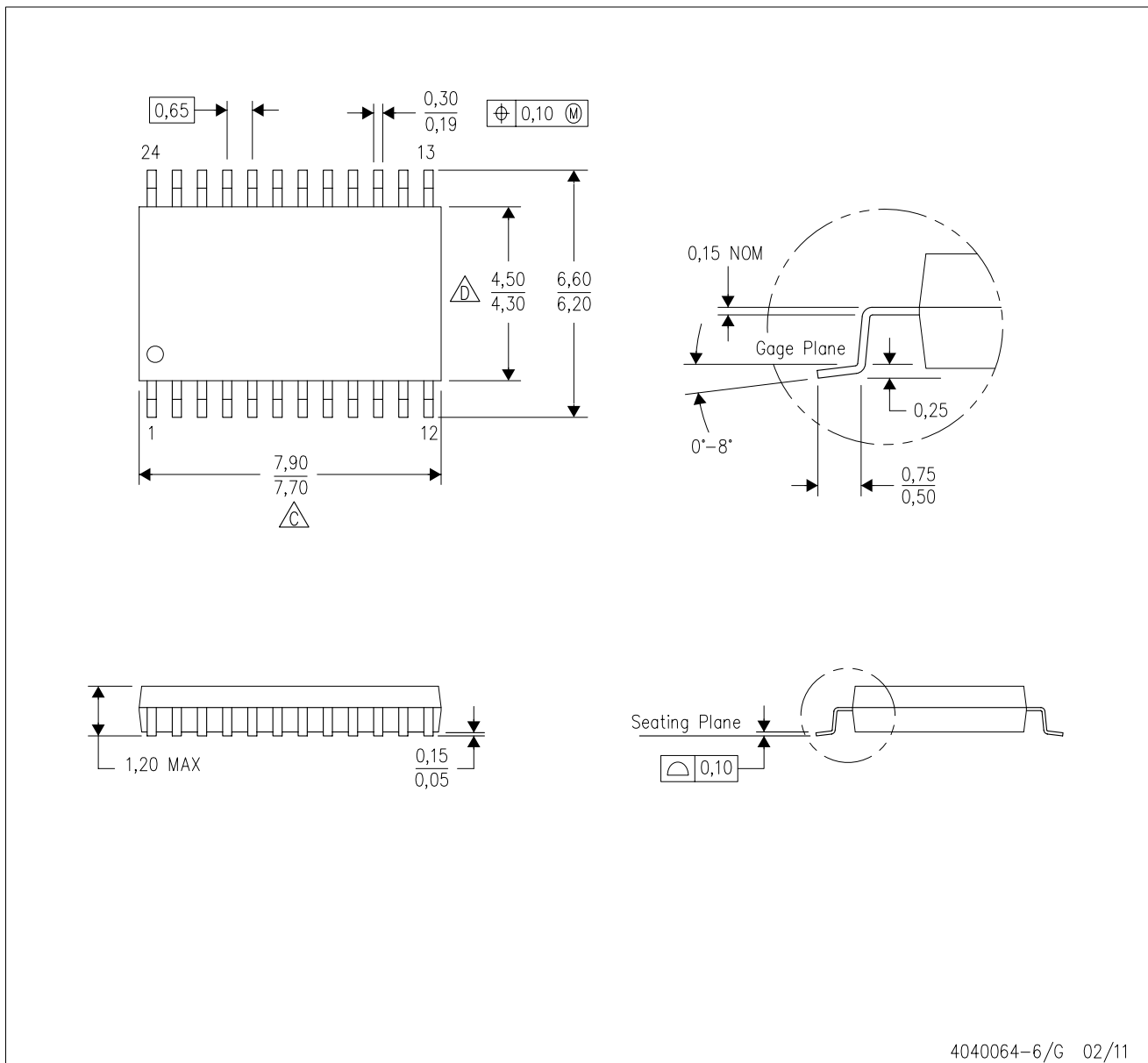
PLASTIC SMALL OUTLINE



4040064-6/G 02/11

- NOTES:
- A. All linear dimensions are in millimeters. Dimensioning and tolerancing per ASME Y14.5M-1994.
  - B. This drawing is subject to change without notice.
  -  C. Body length does not include mold flash, protrusions, or gate burrs. Mold flash, protrusions, or gate burrs shall not exceed 0,15 each side.
  -  D. Body width does not include interlead flash. Interlead flash shall not exceed 0,25 each side.
  - E. Falls within JEDEC MO-153

PW (R-PDSO-G24)

PLASTIC SMALL OUTLINE

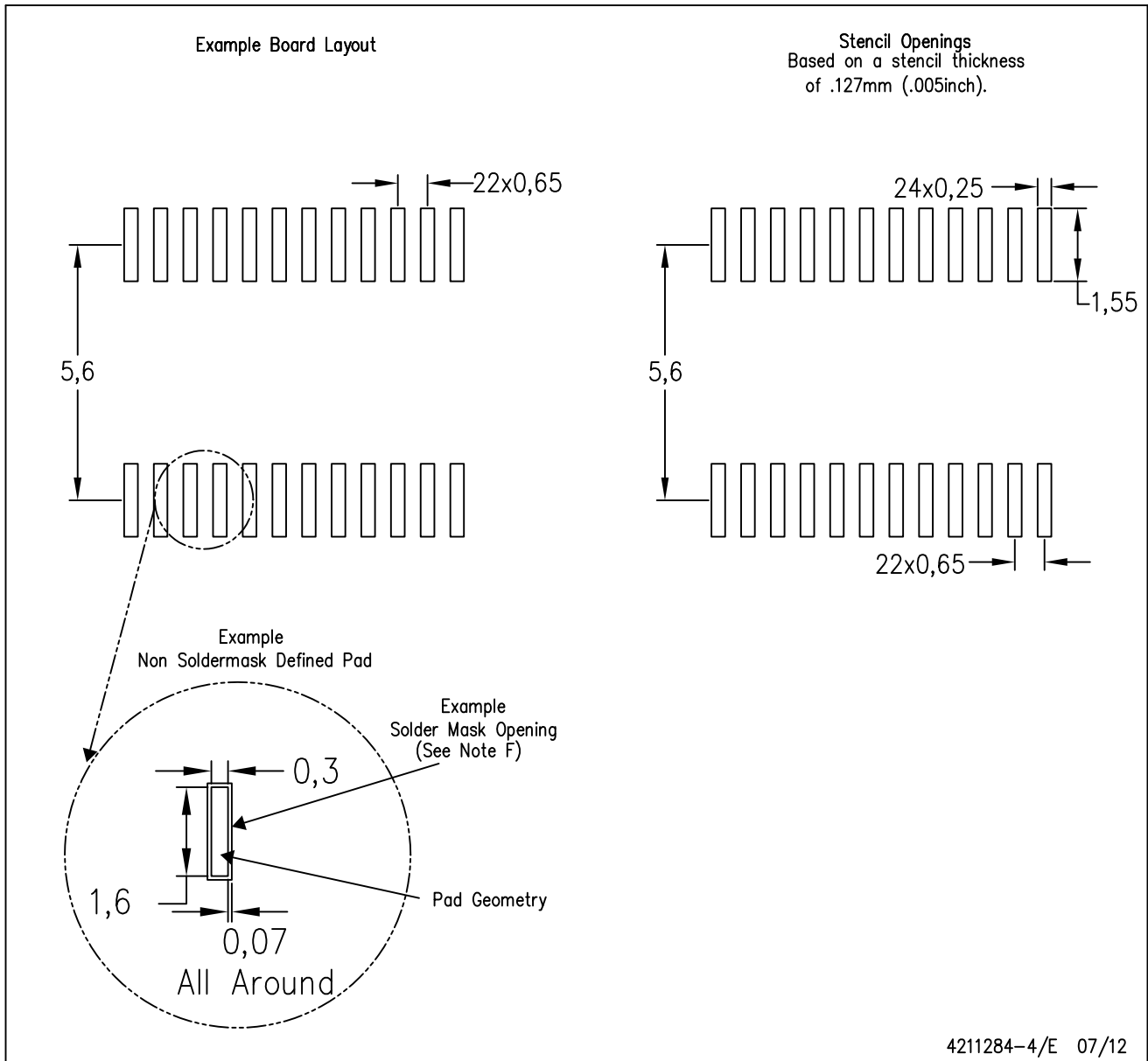

- NOTES:
- All linear dimensions are in millimeters.
  - This drawing is subject to change without notice.
  - Publication IPC-7351 is recommended for alternate design.
  - Laser cutting apertures with trapezoidal walls and also rounding corners will offer better paste release. Customers should contact their board assembly site for stencil design recommendations. Refer to IPC-7525 for other stencil recommendations.
  - Customers should contact their board fabrication site for solder mask tolerances between and around signal pads.

RGE (S-PVQFN-N24)

PLASTIC QUAD FLATPACK NO-LEAD

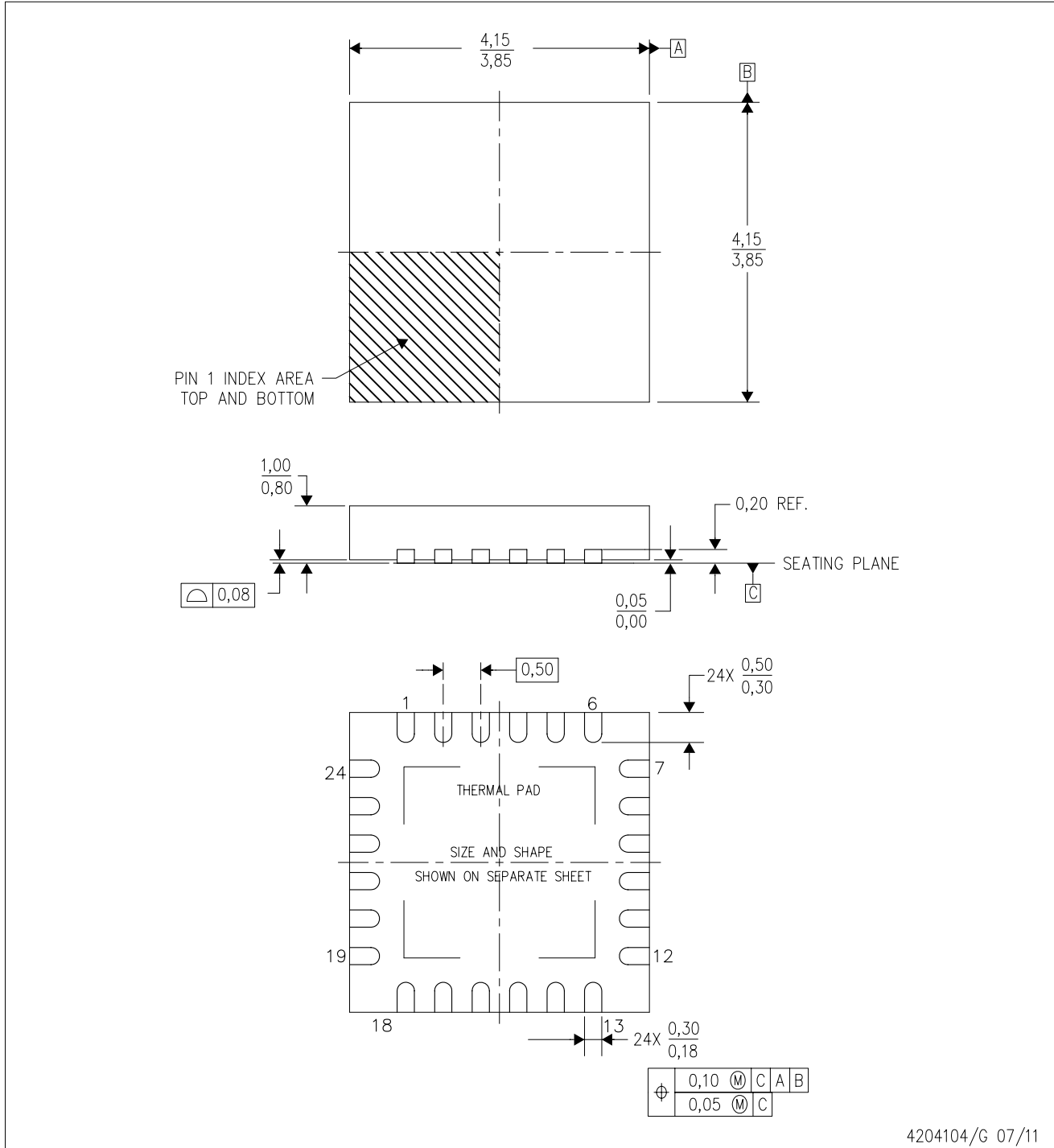

4204104/G 07/11

- NOTES:
- All linear dimensions are in millimeters. Dimensioning and tolerancing per ASME Y14.5M-1994.
  - This drawing is subject to change without notice.
  - Quad Flatpack, No-Leads (QFN) package configuration.
  - The package thermal pad must be soldered to the board for thermal and mechanical performance.
  - See the additional figure in the Product Data Sheet for details regarding the exposed thermal pad features and dimensions.
  - Falls within JEDEC MO-220.

# THERMAL PAD MECHANICAL DATA

RGE (S-PVQFN-N24)

PLASTIC QUAD FLATPACK NO-LEAD

## THERMAL INFORMATION

This package incorporates an exposed thermal pad that is designed to be attached directly to an external heatsink. The thermal pad must be soldered directly to the printed circuit board (PCB). After soldering, the PCB can be used as a heatsink. In addition, through the use of thermal vias, the thermal pad can be attached directly to the appropriate copper plane shown in the electrical schematic for the device, or alternatively, can be attached to a special heatsink structure designed into the PCB. This design optimizes the heat transfer from the integrated circuit (IC).

For information on the Quad Flatpack No-Lead (QFN) package and its advantages, refer to Application Report, QFN/SON PCB Attachment, Texas Instruments Literature No. SLUA271. This document is available at [www.ti.com](http://www.ti.com).

The exposed thermal pad dimensions for this package are shown in the following illustration.

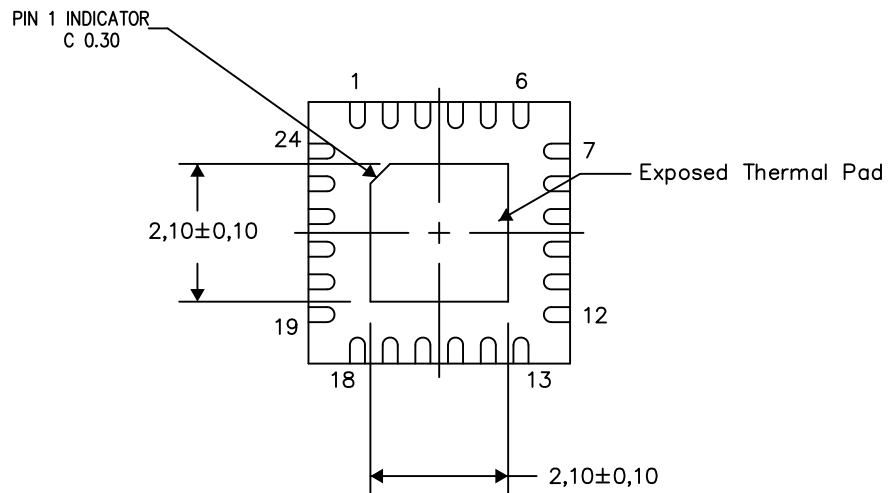

Bottom View

Exposed Thermal Pad Dimensions

4206344-6/AB 09/12

NOTES: A. All linear dimensions are in millimeters

RGE (S-PVQFN-N24)

PLASTIC QUAD FLATPACK NO-LEAD

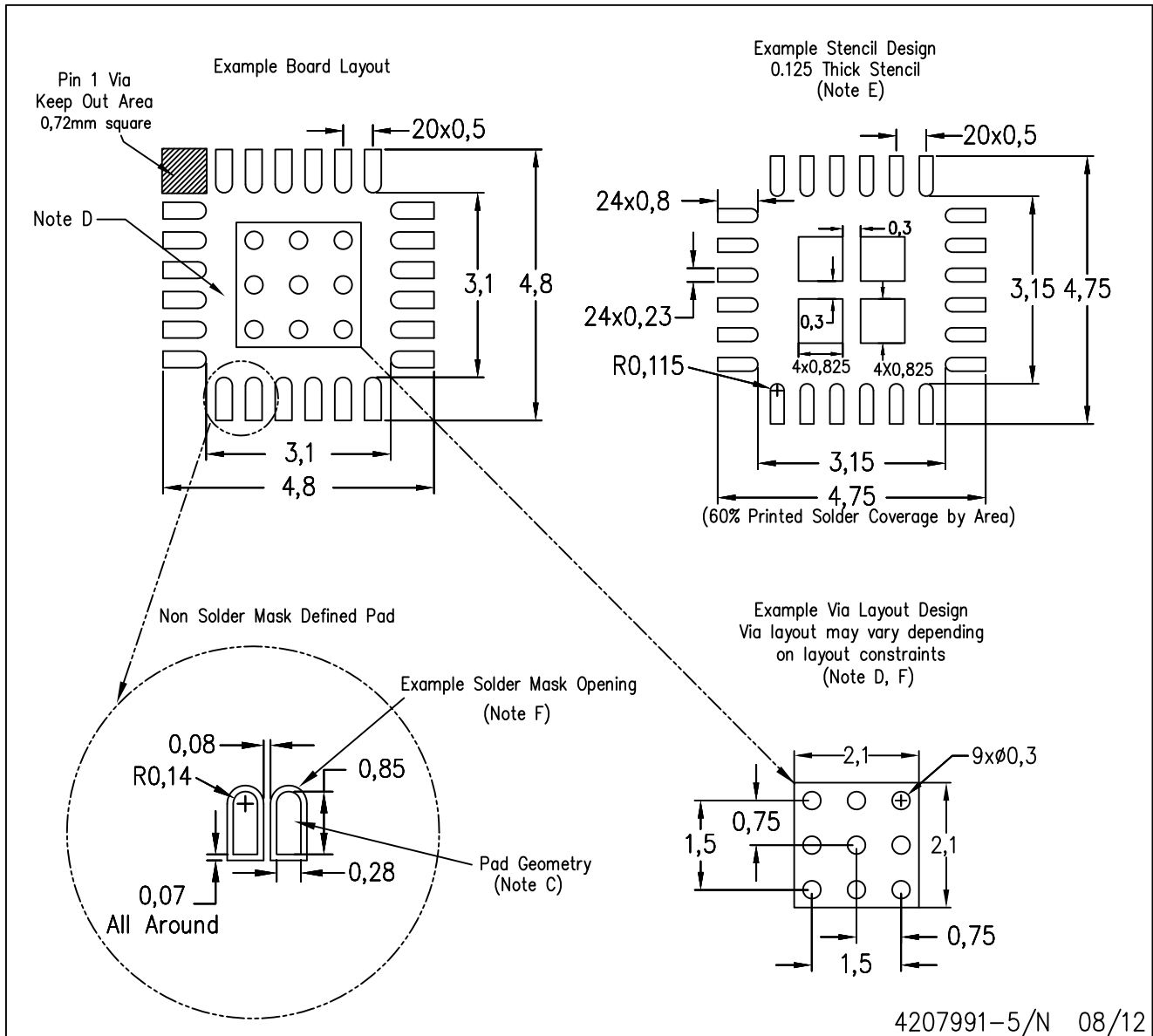

- NOTES:
- All linear dimensions are in millimeters.
  - This drawing is subject to change without notice.
  - Publication IPC-7351 is recommended for alternate designs.
  - This package is designed to be soldered to a thermal pad on the board. Refer to Application Note, Quad Flat-Pack Packages, Texas Instruments Literature No. SLUA271, and also the Product Data Sheets for specific thermal information, via requirements, and recommended board layout. These documents are available at [www.ti.com](http://www.ti.com) <<http://www.ti.com>>.
  - Laser cutting apertures with trapezoidal walls and also rounding corners will offer better paste release. Customers should contact their board assembly site for stencil design recommendations. Refer to IPC 7525 for stencil design considerations.
  - Customers should contact their board fabrication site for recommended solder mask tolerances and via tenting recommendations for vias placed in the thermal pad.

# MECHANICAL DATA

RHL (R-PVQFN-N24)

PLASTIC QUAD FLATPACK NO-LEAD

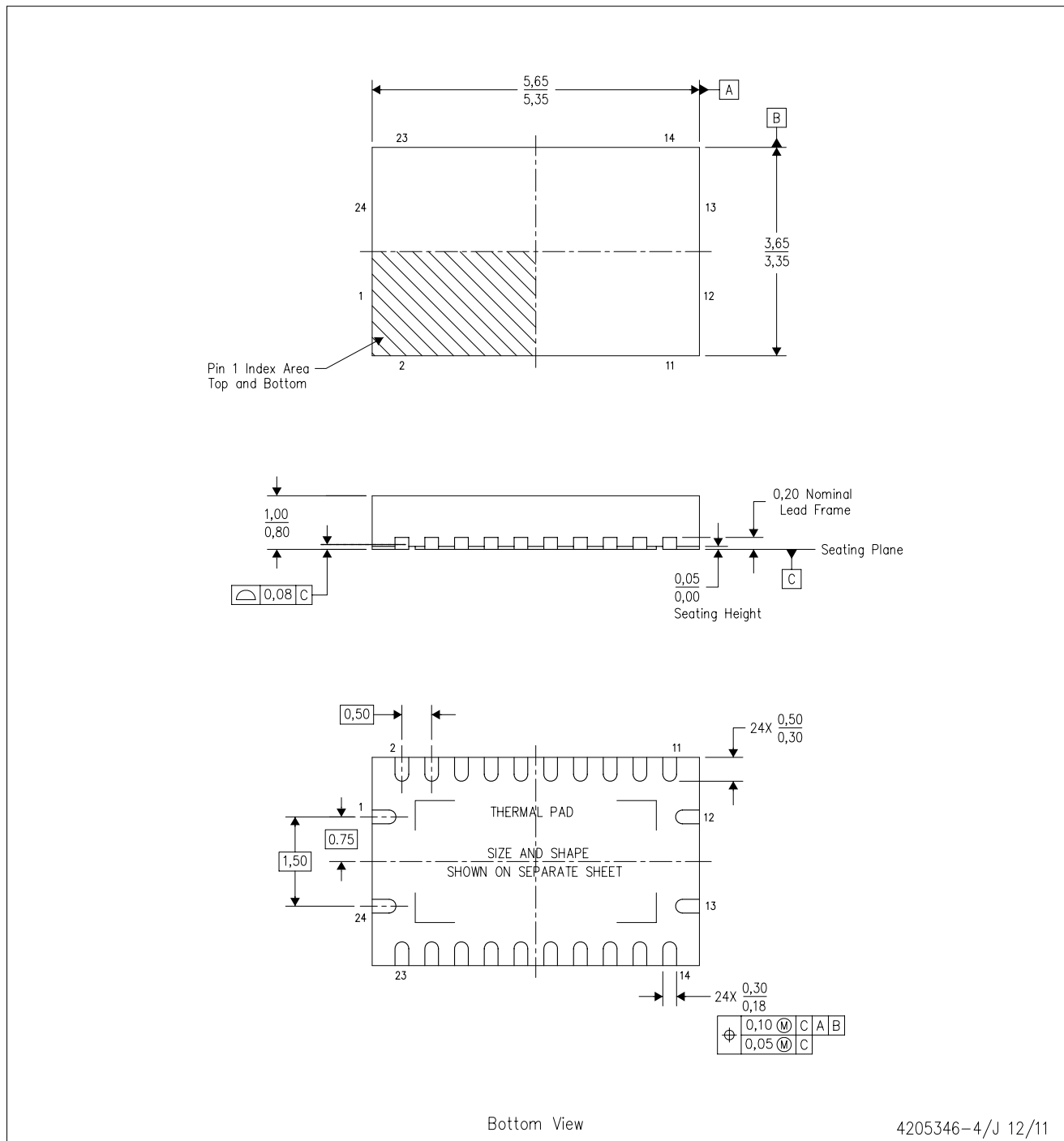

- NOTES:
- All linear dimensions are in millimeters. Dimensioning and tolerancing per ASME Y14.5M-1994.
  - This drawing is subject to change without notice.
  - QFN (Quad Flatpack No-Lead) package configuration.
  - The package thermal pad must be soldered to the board for thermal and mechanical performance.
  - See the additional figure in the Product Data Sheet for details regarding the exposed thermal pad features and dimensions.
  - JEDEC MO-241 package registration pending.

DB (R-PDSO-G\*\*)

PLASTIC SMALL-OUTLINE

28 PINS SHOWN



- NOTES: A. All linear dimensions are in millimeters.  
 B. This drawing is subject to change without notice.  
 C. Body dimensions do not include mold flash or protrusion not to exceed 0,15.  
 D. Falls within JEDEC MO-150

## IMPORTANT NOTICE

Texas Instruments Incorporated and its subsidiaries (TI) reserve the right to make corrections, enhancements, improvements and other changes to its semiconductor products and services per JESD46, latest issue, and to discontinue any product or service per JESD48, latest issue. Buyers should obtain the latest relevant information before placing orders and should verify that such information is current and complete. All semiconductor products (also referred to herein as "components") are sold subject to TI's terms and conditions of sale supplied at the time of order acknowledgment.

TI warrants performance of its components to the specifications applicable at the time of sale, in accordance with the warranty in TI's terms and conditions of sale of semiconductor products. Testing and other quality control techniques are used to the extent TI deems necessary to support this warranty. Except where mandated by applicable law, testing of all parameters of each component is not necessarily performed.

TI assumes no liability for applications assistance or the design of Buyers' products. Buyers are responsible for their products and applications using TI components. To minimize the risks associated with Buyers' products and applications, Buyers should provide adequate design and operating safeguards.

TI does not warrant or represent that any license, either express or implied, is granted under any patent right, copyright, mask work right, or other intellectual property right relating to any combination, machine, or process in which TI components or services are used. Information published by TI regarding third-party products or services does not constitute a license to use such products or services or a warranty or endorsement thereof. Use of such information may require a license from a third party under the patents or other intellectual property of the third party, or a license from TI under the patents or other intellectual property of TI.

Reproduction of significant portions of TI information in TI data books or data sheets is permissible only if reproduction is without alteration and is accompanied by all associated warranties, conditions, limitations, and notices. TI is not responsible or liable for such altered documentation. Information of third parties may be subject to additional restrictions.

Resale of TI components or services with statements different from or beyond the parameters stated by TI for that component or service voids all express and any implied warranties for the associated TI component or service and is an unfair and deceptive business practice. TI is not responsible or liable for any such statements.

Buyer acknowledges and agrees that it is solely responsible for compliance with all legal, regulatory and safety-related requirements concerning its products, and any use of TI components in its applications, notwithstanding any applications-related information or support that may be provided by TI. Buyer represents and agrees that it has all the necessary expertise to create and implement safeguards which anticipate dangerous consequences of failures, monitor failures and their consequences, lessen the likelihood of failures that might cause harm and take appropriate remedial actions. Buyer will fully indemnify TI and its representatives against any damages arising out of the use of any TI components in safety-critical applications.

In some cases, TI components may be promoted specifically to facilitate safety-related applications. With such components, TI's goal is to help enable customers to design and create their own end-product solutions that meet applicable functional safety standards and requirements. Nonetheless, such components are subject to these terms.

No TI components are authorized for use in FDA Class III (or similar life-critical medical equipment) unless authorized officers of the parties have executed a special agreement specifically governing such use.

Only those TI components which TI has specifically designated as military grade or "enhanced plastic" are designed and intended for use in military/aerospace applications or environments. Buyer acknowledges and agrees that any military or aerospace use of TI components which have **not** been so designated is solely at the Buyer's risk, and that Buyer is solely responsible for compliance with all legal and regulatory requirements in connection with such use.

TI has specifically designated certain components which meet ISO/TS16949 requirements, mainly for automotive use. Components which have not been so designated are neither designed nor intended for automotive use; and TI will not be responsible for any failure of such components to meet such requirements.

### Products

Audio	<a href="http://www.ti.com/audio">www.ti.com/audio</a>
Amplifiers	<a href="http://amplifier.ti.com">amplifier.ti.com</a>
Data Converters	<a href="http://dataconverter.ti.com">dataconverter.ti.com</a>
DLP® Products	<a href="http://www.dlp.com">www.dlp.com</a>
DSP	<a href="http://dsp.ti.com">dsp.ti.com</a>
Clocks and Timers	<a href="http://www.ti.com/clocks">www.ti.com/clocks</a>
Interface	<a href="http://interface.ti.com">interface.ti.com</a>
Logic	<a href="http://logic.ti.com">logic.ti.com</a>
Power Mgmt	<a href="http://power.ti.com">power.ti.com</a>
Microcontrollers	<a href="http://microcontroller.ti.com">microcontroller.ti.com</a>
RFID	<a href="http://www.ti-rfid.com">www.ti-rfid.com</a>
OMAP Applications Processors	<a href="http://www.ti.com/omap">www.ti.com/omap</a>
Wireless Connectivity	<a href="http://www.ti.com/wirelessconnectivity">www.ti.com/wirelessconnectivity</a>

### Applications

Automotive and Transportation	<a href="http://www.ti.com/automotive">www.ti.com/automotive</a>
Communications and Telecom	<a href="http://www.ti.com/communications">www.ti.com/communications</a>
Computers and Peripherals	<a href="http://www.ti.com/computers">www.ti.com/computers</a>
Consumer Electronics	<a href="http://www.ti.com/consumer-apps">www.ti.com/consumer-apps</a>
Energy and Lighting	<a href="http://www.ti.com/energy">www.ti.com/energy</a>
Industrial	<a href="http://www.ti.com/industrial">www.ti.com/industrial</a>
Medical	<a href="http://www.ti.com/medical">www.ti.com/medical</a>
Security	<a href="http://www.ti.com/security">www.ti.com/security</a>
Space, Avionics and Defense	<a href="http://www.ti.com/space-avionics-defense">www.ti.com/space-avionics-defense</a>
Video and Imaging	<a href="http://www.ti.com/video">www.ti.com/video</a>

### TI E2E Community

[e2e.ti.com](http://e2e.ti.com)