

# 24LC21

## 1K 2.5V Dual Mode I<sup>2</sup>C™ Serial EEPROM

### Features:

- Single supply with operation down to 2.5V
- Completely implements DDC1™/DDC2™ interface for monitor identification
- Low-power CMOS technology:
  - 1 mA active current typical
  - 10 µA standby current typical at 5.5V
- 2-wire serial interface bus, I<sup>2</sup>C™ compatible
- Self-timed write cycle (including auto-erase)
- Page-write buffer for up to 8 bytes
- 100 kHz (2.5V) and 400 kHz (5V) compatibility
- Factory programming (QTP) available
- 1,000,000 erase/write cycles ensured
- Data retention > 200 years
- 8-pin PDIP and SOIC package
- Available for extended temperature ranges
  - Commercial (C): 0°C to +70°C
  - Industrial (I): -40°C to +85°C

### Description:

The Microchip Technology Inc. 24LC21 is a 128 x 8 bit Electrically Erasable PROM. This device is designed for use in applications requiring storage and serial transmission of configuration and control information. Two modes of operation have been implemented: Transmit-only mode and Bidirectional mode. Upon power-up, the device will be in the Transmit-only mode, sending a serial bit stream of the entire memory array contents, clocked by the VCLK pin. A valid high-to-low transition on the SCL pin will cause the device to enter the Bidirectional mode, with byte selectable read/write capability of the memory array. The 24LC21 is available in a standard 8-pin PDIP and SOIC package, in both commercial and industrial temperature ranges.

### Package Types

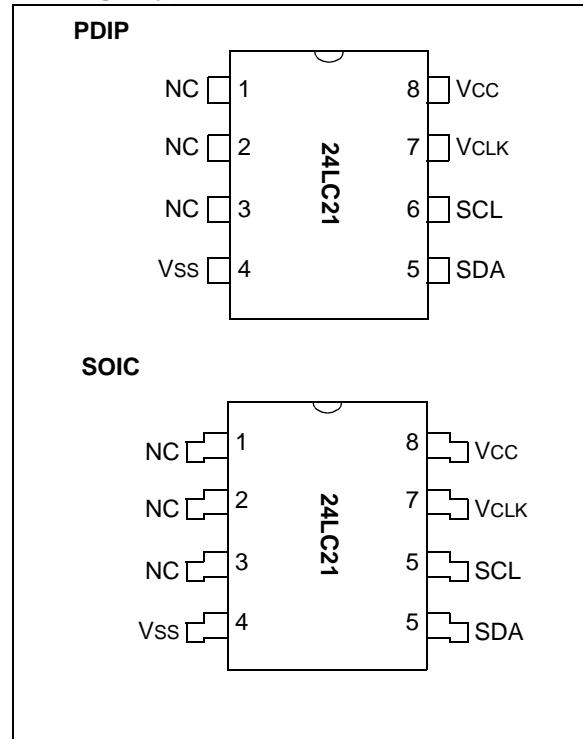

### Block Diagram

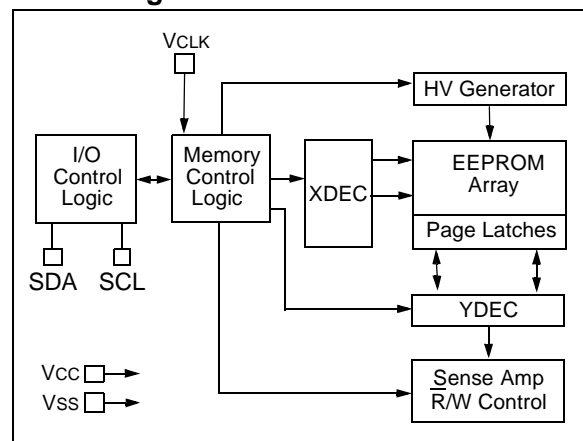

I<sup>2</sup>C is a trademark of Philips Corporation.  
DDC is a trademark of the Video Electronics Standards Association.

# 24LC21

## 1.0 ELECTRICAL CHARACTERISTICS

### Absolute Maximum Ratings<sup>(†)</sup>

V <sub>CC</sub> .....	7.0V
All inputs and outputs w.r.t. V <sub>SS</sub> .....	-0.6V to V <sub>CC</sub> + 1.0V
Storage temperature .....	-65°C to +150°C
Ambient temperature with power applied.....	-40°C to +125°C
Soldering temperature of leads (10 seconds) .....	+300°C
ESD protection on all pins .....	≥ 4 kV

† NOTICE: Stresses above those listed under “Absolute Maximum Ratings” may cause permanent damage to the device. This is a stress rating only and functional operation of the device at these or any other conditions above those indicated in the operational listings of this specification is not implied. Exposure to Absolute Maximum Rating conditions for extended periods may affect device reliability.

**TABLE 1-1: DC CHARACTERISTICS**

DC CHARACTERISTICS	V <sub>CC</sub> = +2.5V to 5.5V				
	Commercial (C): TA = 0°C to +70°C Industrial (I): TA = -40°C to +85°C				
Parameter	Symbol	Min	Max	Units	Conditions
SCL and SDA pins:					
High-level input voltage	V <sub>IH</sub>	.7 V <sub>CC</sub>	—	V	—
Low-level input voltage	V <sub>IL</sub>	—	.3 V <sub>CC</sub>	V	—
Input levels on V <sub>CLK</sub> pin:					
High-level input voltage	V <sub>IH</sub>	2.0	.8	V	V <sub>CC</sub> ≥ 2.7V ( <b>Note 1</b> )
Low-level input voltage	V <sub>IL</sub>	—	.2 V <sub>CC</sub>	V	V <sub>CC</sub> < 2.7V ( <b>Note 1</b> )
Hysteresis of Schmitt Trigger inputs	V <sub>HYS</sub>	.05 V <sub>CC</sub>	—	V	<b>(Note 1)</b>
Low-level output voltage	V <sub>OL1</sub>	—	.4	V	I <sub>OL</sub> = 3 mA, V <sub>CC</sub> = 2.5V ( <b>Note 1</b> )
Low-level output voltage	V <sub>OL2</sub>	—	.6	V	I <sub>OL</sub> = 6 mA, V <sub>CC</sub> = 2.5V
Input leakage current	I <sub>LI</sub>	-10	10	μA	V <sub>IN</sub> = .1V to V <sub>CC</sub>
Output leakage current	I <sub>LO</sub>	-10	10	μA	V <sub>OUT</sub> = .1V to V <sub>CC</sub>
Pin capacitance (all inputs/outputs)	C <sub>IN</sub> , C <sub>OUT</sub>	—	10	pF	V <sub>CC</sub> = 5.0V ( <b>Note1</b> ), TA = 25°C, F <sub>CLK</sub> = 1 MHz
Operating current	I <sub>CC</sub> Write I <sub>CC</sub> Read	— —	3 1	mA mA	V <sub>CC</sub> = 5.5V, SCL = 400 kHz
Standby current	I <sub>CCS</sub>	— —	30 100	μA μA	V <sub>CC</sub> = 3.0V, SDA = SCL = V <sub>CC</sub> V <sub>CC</sub> = 5.5V, SDA = SCL = V <sub>CC</sub> <b>(Note 2)</b>

**Note 1:** This parameter is periodically sampled and not 100% tested.

**2:** V<sub>LCK</sub> must be grounded.

TABLE 1-2: AC CHARACTERISTICS

Parameter	Symbol	Standard Mode		V <sub>CC</sub> = 4.5 - 5.5V Fast Mode		Units	Remarks
		Min	Max	Min	Max		
Clock frequency	FCLK	—	100	—	400	kHz	—
Clock high time	THIGH	4000	—	600	—	ns	—
Clock low time	TLOW	4700	—	1300	—	ns	—
SDA and SCL rise time	TR	—	1000	—	300	ns	<b>(Note 1)</b>
SDA and SCL fall time	TF	—	300	—	300	ns	<b>(Note 1)</b>
Start condition hold time	THD:STA	4000	—	600	—	ns	After this period the first clock pulse is generated
Start condition setup time	TSU:STA	4700	—	600	—	ns	Only relevant for repeated Start condition
Data input hold time	THD:DAT	0	—	0	—	ns	<b>(Note 2)</b>
Data input setup time	TSU:DAT	250	—	100	—	ns	—
Stop condition setup time	TSU:STO	4000	—	600	—	ns	—
Output valid from clock	TAA	—	3500	—	900	ns	<b>(Note 2)</b>
Bus free time	TBUF	4700	—	1300	—	ns	Time the bus must be free before a new transmission can start
Output fall time from VIH min. to VIL max.	TOF	—	250	20 + .1 Cb	250	ns	<b>(Note 1)</b> , C <sub>B</sub> ≤ 100 pF
Input filter spike suppression (SDA and SCL pins)	TSP	—	50	—	50	ns	<b>(Note 3)</b>
Write cycle time	TWR	—	10	—	10	ms	Byte or Page mode
<b>Transmit-only Mode Parameters</b>							
Output valid from VCLK	TVAA	—	2000	—	1000	ns	—
VCLK high time	TVHIGH	4000	—	600	—	ns	—
VCLK low time	TVLOW	4700	—	1300	—	ns	—
Mode transition time	TVHZ	—	500	—	500	ns	—
Transmit-only power-up time	TVPU	0	—	0	—	ns	—
Endurance	—	1M	—	1M	—	cycles	25°C, V <sub>CC</sub> = 5.0V, Block mode <b>(Note 4)</b>

**Note 1:** Not 100% tested. C<sub>B</sub> = total capacitance of one bus line in pF.

**2:** As a transmitter, the device must provide an internal minimum delay time to bridge the undefined region (minimum 300 ns) of the falling edge of SCL to avoid unintended generation of Start or Stop conditions.

**3:** The combined TSP and VHYS specifications are due to new Schmitt Trigger inputs which provide improved noise and spike suppression. This eliminates the need for a TI specification for standard operation.

**4:** This parameter is not tested but ensured by characterization. For endurance estimates in a specific application, please consult the Total Endurance™ Model which can be obtained from Microchip's web site at: [www.microchip.com](http://www.microchip.com)

# 24LC21

## 2.0 FUNCTIONAL DESCRIPTION

The 24LC21 operates in two modes, the Transmit-only mode and the Bidirectional mode. There is a separate two wire protocol to support each mode, each having a separate clock input and sharing a common data line (SDA). The device enters the Transmit-only mode upon power-up. In this mode, the device transmits data bits on the SDA pin in response to a clock signal on the VCLK pin. The device will remain in this mode until a valid high-to-low transition is placed on the SCL input. When a valid transition on SCL is recognized, the device will switch into the Bidirectional mode. The only way to switch the device back to the Transmit-only mode is to remove power from the device.

### 2.1 Transmit-only Mode

The device will power-up in the Transmit-only mode. This mode supports a unidirectional two wire protocol for transmission of the contents of the memory array. This device requires that it be initialized prior to valid data being sent in the Transmit-only mode (see Initialization Procedure, below). In this mode, data is trans-

mitted on the SDA pin in 8-bit bytes, each followed by a ninth, null bit (see Figure 2-1). The clock source for the Transmit-only mode is provided on the VCLK pin, and a data bit is output on the rising edge of this pin. The eight bits in each byte are transmitted Most Significant bit first. Each byte within the memory array will be output in sequence. When the last byte in the memory array is transmitted, the output will wrap around to the first location and continue. The Bidirectional mode Clock (SCL) pin must be held high for the device to remain in the Transmit-only mode.

### 2.2 Initialization Procedure

After VCC has stabilized, the device will be in the Transmit-only mode. Nine clock cycles on the VCLK pin must be given to the device for it to perform internal synchronization. During this period, the SDA pin will be in a high-impedance state. On the rising edge of the tenth clock cycle, the device will output the first valid data bit which will be the Most Significant bit of a byte. The device will power-up at an indeterminate byte address. (Figure 2-2).

FIGURE 2-1: TRANSMIT-ONLY MODE

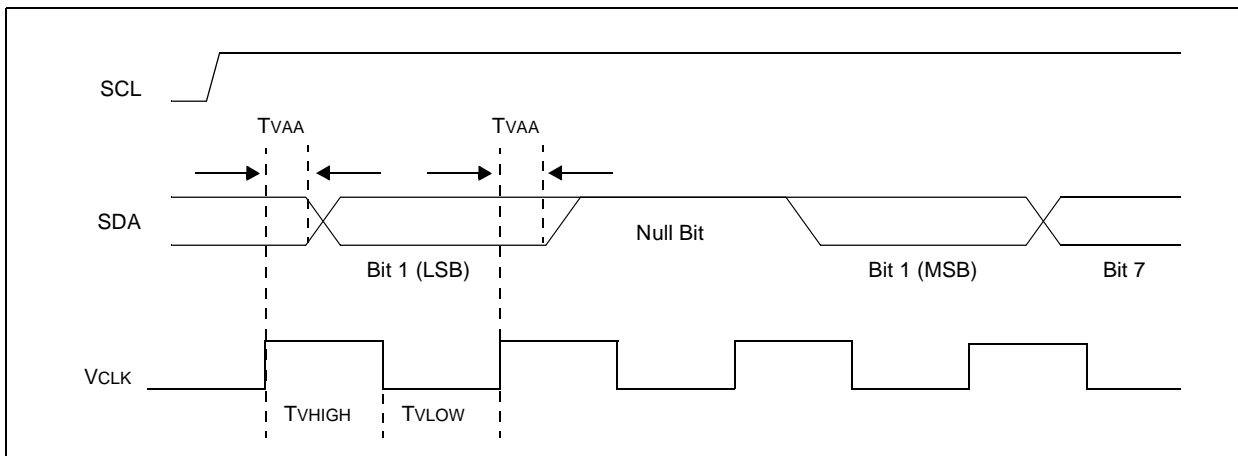
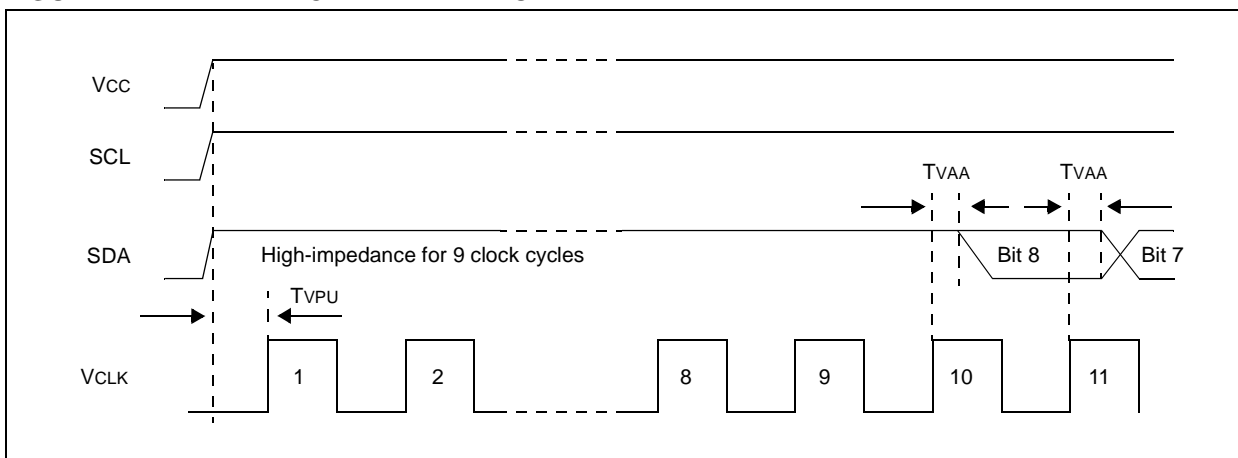

FIGURE 2-2: DEVICE INITIALIZATION



## 3.0 BIDIRECTIONAL MODE

The 24LC21 can be switched into the Bidirectional mode (see Figure 3-1) by applying a valid high-to-low transition on the Bidirectional mode clock (SCL). When the device has been switched into the Bidirectional mode, the VCLK input is disregarded, with the exception that a logic high level is required to enable write capability. This mode supports a two wire bidirectional data transmission protocol. In this protocol, a device that sends data on the bus is defined to be the transmitter, and a device that receives data from the bus is defined to be the receiver. The bus must be controlled by a master device that generates the Bidirectional mode clock (SCL), controls access to the bus and generates the Start and Stop conditions, while the 24LC21 acts as the slave. Both master and slave can operate as transmitter or receiver, but the master device determines which mode is activated.

## 3.1 Bidirectional Mode Bus Characteristics

The following **bus protocol** has been defined:

- Data transfer may be initiated only when the bus is not busy.
- During data transfer, the data line must remain stable whenever the clock line is high. Changes in the data line while the clock line is high will be interpreted as a Start or Stop condition.

Accordingly, the following bus conditions have been defined (see Figure 3-2).

### 3.1.1 BUS NOT BUSY (A)

Both data and clock lines remain high.

### 3.1.2 START DATA TRANSFER (B)

A high-to-low transition of the SDA line while the clock (SCL) is high determines a Start condition. All commands must be preceded by a Start condition.

### 3.1.3 STOP DATA TRANSFER (C)

A low-to-high transition of the SDA line while the clock (SCL) is high determines a Stop condition. All operations must be ended with a Stop condition.

**FIGURE 3-1: MODE TRANSITION**

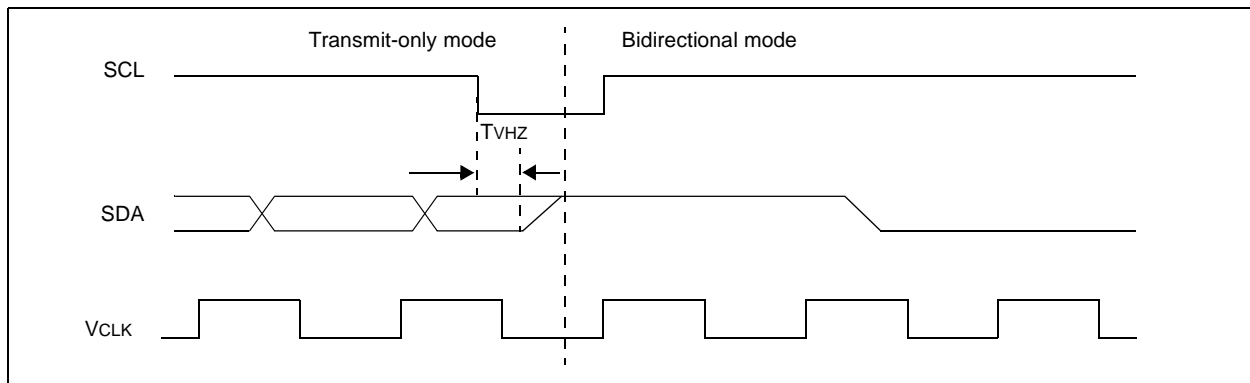

**FIGURE 3-2: DATA TRANSFER SEQUENCE ON THE SERIAL BUS**

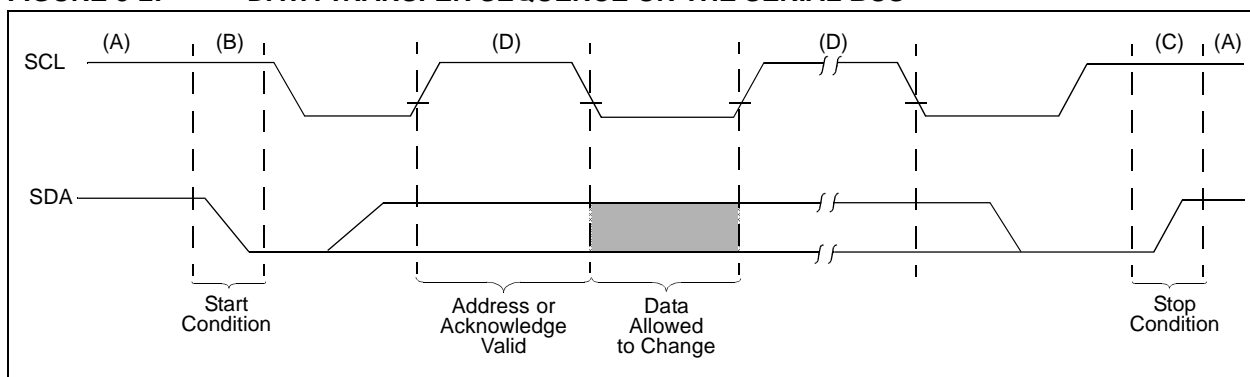

# 24LC21

## 3.1.4 DATA VALID (D)

The state of the data line represents valid data when, after a Start condition, the data line is stable for the duration of the high period of the clock signal.

The data on the line must be changed during the low period of the clock signal. There is one clock pulse per bit of data.

Each data transfer is initiated with a Start condition and terminated with a Stop condition. The number of the data bytes transferred between the Start and Stop conditions is determined by the master device and is theoretically unlimited, although only the last eight will be stored when doing a write operation. When an overwrite does occur, it will replace data in a first in first out fashion.

## 3.1.5 ACKNOWLEDGE

Each receiving device, when addressed, is obliged to generate an acknowledge after the reception of each byte. The master device must generate an extra clock pulse which is associated with this Acknowledge bit.

**Note:** The 24LC21 does not generate any Acknowledge bits if an internal programming cycle is in progress.

The device that acknowledges has to pull down the SDA line during the acknowledge clock pulse in such a way that the SDA line is stable low during the high period of the acknowledge related clock pulse. Of course, setup and hold times must be taken into account. A master must signal an end of data to the slave by not generating an Acknowledge bit on the last byte that has been clocked out of the slave. In this case, the slave must leave the data line high to enable the master to generate the Stop condition.

**FIGURE 3-3: BUS TIMING START/STOP**

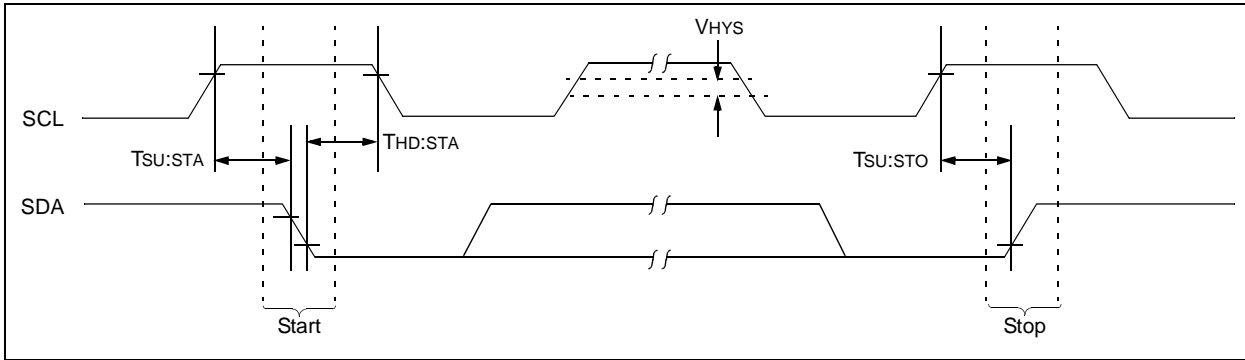

**FIGURE 3-4: BUS TIMING DATA**

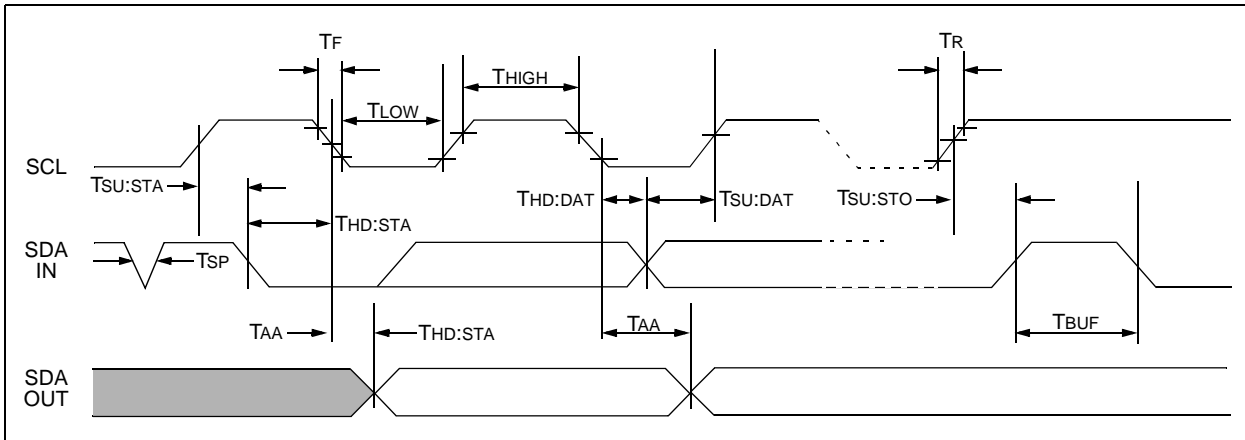

### 3.1.6 SLAVE ADDRESS

After generating a Start condition, the bus master transmits the slave address consisting of a 7-bit device code '1010' for the 24LC21, followed by three "don't care" bits.

The eighth bit of slave address determines if the master device wants to read or write to the 24LC21 (Figure 3-5).

The 24LC21 monitors the bus for its corresponding slave address all the time. It generates an Acknowledge bit if the slave address was true and it is not in a programming mode.

Operation	Control Code	Chip Select	R/W
Read	1010	xxx	1
Write	1010	xxx	0

**FIGURE 3-5: CONTROL BYTE ALLOCATION**

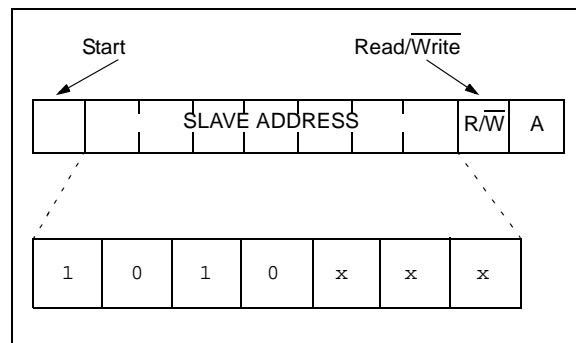

## 4.0 WRITE OPERATION

### 4.1 Byte Write

Following the Start signal from the master, the slave address (4 bits), the "don't care" bits (3 bits) and the R/W bit which is a logic low, is placed onto the bus by the master transmitter. This indicates to the addressed slave receiver that a byte with a word address will follow after it has generated an Acknowledge bit during the ninth clock cycle. Therefore, the next byte transmitted by the master is the word address and will be written into the address pointer of the 24LC21. After receiving another Acknowledge signal from the 24LC21 the master device will transmit the data word to be written into the addressed memory location. The 24LC21 acknowledges again and the master generates a Stop condition. This initiates the internal write cycle, and during this time the 24LC21 will not generate Acknowledge signals (Figure 4-1).

It is required that VCLK be held at a logic high level in order to program the device. This applies to byte write and page write operation. Note that VCLK can go low while the device is in its self-timed program operation and not affect programming.

### 4.2 Page Write

The write control byte, word address and the first data byte are transmitted to the 24LC21 in the same way as in a byte write. But instead of generating a Stop condition the master transmits up to eight data bytes to the 24LC21, which are temporarily stored in the on-chip page buffer and will be written into the memory after the master has transmitted a Stop condition. After the receipt of each word, the three lower order address pointer bits are internally incremented by one. The higher order five bits of the word address remains constant. If the master should transmit more than eight words prior to generating the Stop condition, the address counter will roll over and the previously received data will be overwritten. As with the byte write operation, once the Stop condition is received an internal write cycle will begin (Figure 4-3).

# 24LC21

It is required that VCLK be held at a logic high level in order to program the device. This applies to byte write and page write operation. Note that VCLK can go low while the device is in its self-timed program operation and not affect programming.

**Note:** Page write operations are limited to writing bytes within a single physical page, **regardless** of the number of bytes actually being written. Physical page boundaries start at addresses that are integer multiples of the page buffer size (or 'page size') and end at addresses that are integer multiples of [page size - 1]. If a page Write command attempts to write across a physical page boundary, the result is that the data wraps around to the beginning of the current page (overwriting data previously stored there), instead of being written to the next page as might be expected. It is therefore necessary for the application software to prevent page write operations that would attempt to cross a page boundary.

**FIGURE 4-1: BYTE WRITE**

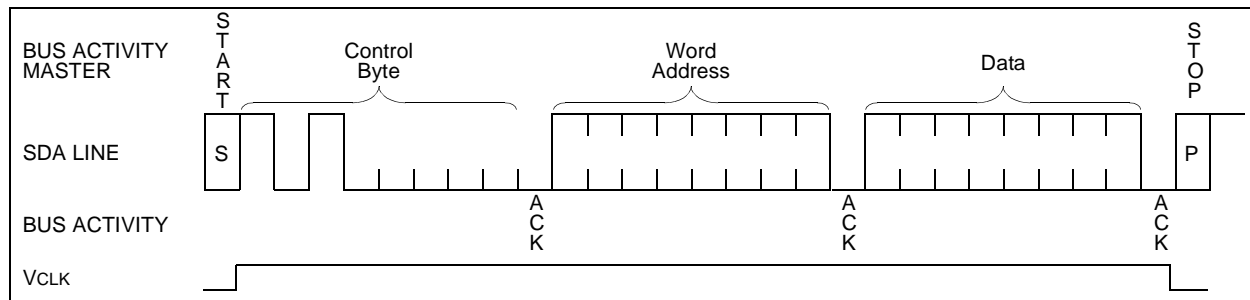

**FIGURE 4-2: BYTE WRITE**

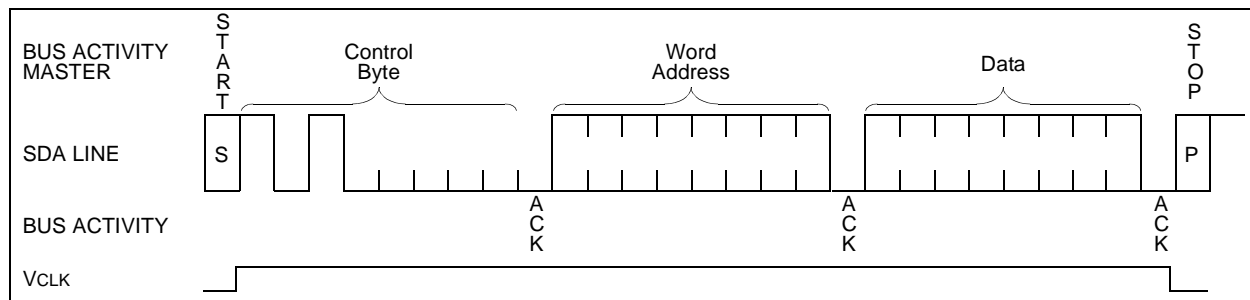

**FIGURE 4-3: PAGE WRITE**

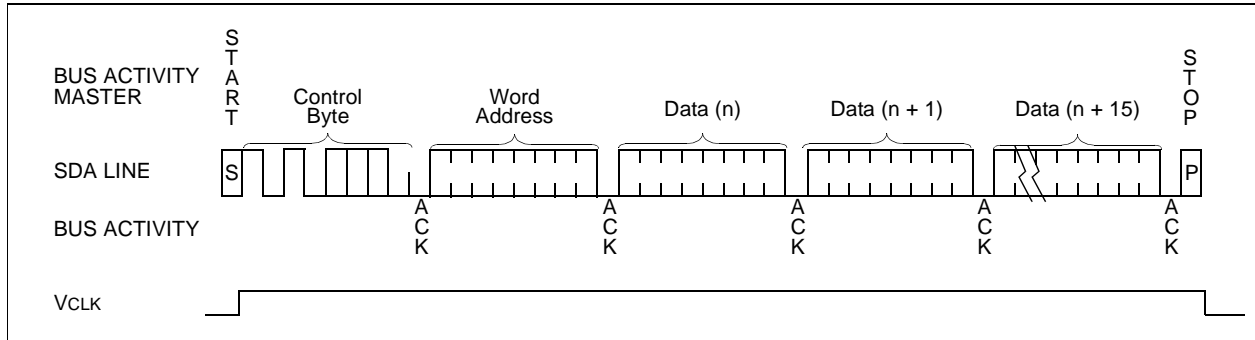

# 24LC21

## 5.0 ACKNOWLEDGE POLLING

Since the device will not acknowledge during a write cycle, this can be used to determine when the cycle is complete (this feature can be used to maximize bus throughput). Once the Stop condition for a Write command has been issued from the master, the device initiates the internally timed write cycle. ACK polling can be initiated immediately. This involves the master sending a Start condition followed by the control byte for a Write command ( $R/\bar{W} = 0$ ). If the device is still busy with the write cycle, then no ACK will be returned. If the cycle is complete, then the device will return the ACK and the master can then proceed with the next Read or Write command. See Figure 5-1 for the flow diagram.

## 6.0 WRITE PROTECTION

When using the 24LC21 in the Bidirectional mode, the VCLK pin operates as the write-protect control pin. Setting VCLK high allows normal write operations, while setting VCLK low prevents writing to any location in the array. Connecting the VCLK pin to VSS would allow the 24LC21 to operate as a serial ROM, although this configuration would prevent using the device in the Transmit-only mode.

**FIGURE 5-1: ACKNOWLEDGE POLLING FLOW**

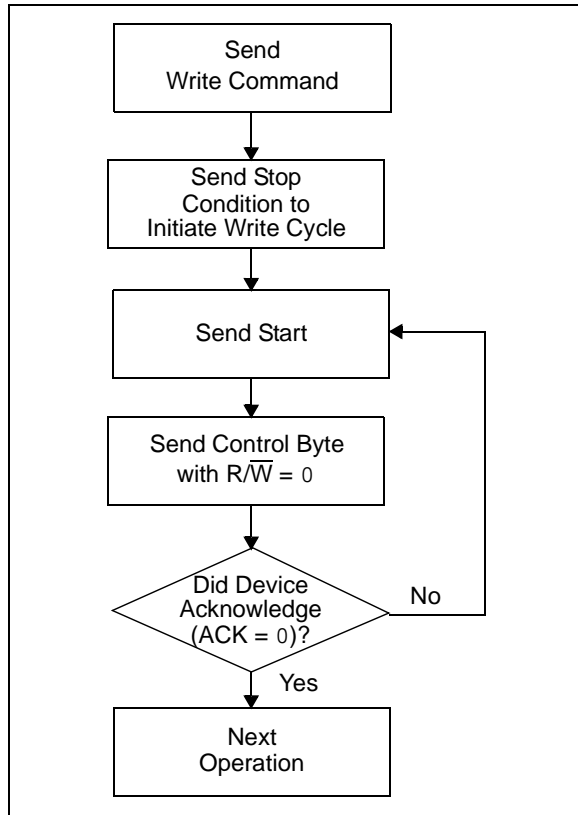

## 7.0 READ OPERATION

Read operations are initiated in the same way as write operations with the exception that the  $R/\overline{W}$  bit of the slave address is set to '1'. There are three basic types of read operations: current address read, random read and sequential read.

### 7.1 Current Address Read

The 24LC21 contains an address counter that maintains the address of the last word accessed, internally incremented by one. Therefore, if the previous access (either a read or write operation) was to address  $n$ , the next current address read operation would access data from address  $n + 1$ . Upon receipt of the slave address with  $R/\overline{W}$  bit set to '1', the 24LC21 issues an acknowledge and transmits the eight bit data word. The master will not acknowledge the transfer but does generate a Stop condition and the 24LC21 discontinues transmission (Figure 7-1).

### 7.2 Random Read

Random read operations allow the master to access any memory location in a random manner. To perform this type of read operation, first the word address must be set. This is done by sending the word address to the 24LC21 as part of a write operation. After the word address is sent, the master generates a Start condition following the acknowledge. This terminates the write operation, but not before the internal address pointer is set. Then the master issues the control byte again but with the  $R/\overline{W}$  bit set to a '1'. The 24LC21 will then issue an acknowledge and transmits the eight bit data word. The master will not acknowledge the transfer but does generate a Stop condition and the 24LC21 discontinues transmission (Figure 7-2).

### 7.3 Sequential Read

Sequential reads are initiated in the same way as a random read except that after the 24LC21 transmits the first data byte, the master issues an acknowledge as opposed to a Stop condition in a random read. This directs the 24LC21 to transmit the next sequentially addressed 8-bit word (see Figure 7-3).

To provide sequential reads the 24LC21 contains an internal address pointer which is incremented by one at the completion of each operation. This address pointer allows the entire memory contents to be serially read during one operation.

### 7.4 Noise Protection

The 24LC21 employs a  $V_{CC}$  threshold detector circuit which disables the internal erase/write logic if the  $V_{CC}$  is below 1.5 volts at nominal conditions.

The SCL and SDA inputs have Schmitt Trigger and filter circuits which suppress noise spikes to assure proper device operation even on a noisy bus.

**FIGURE 7-1: CURRENT ADDRESS READ**

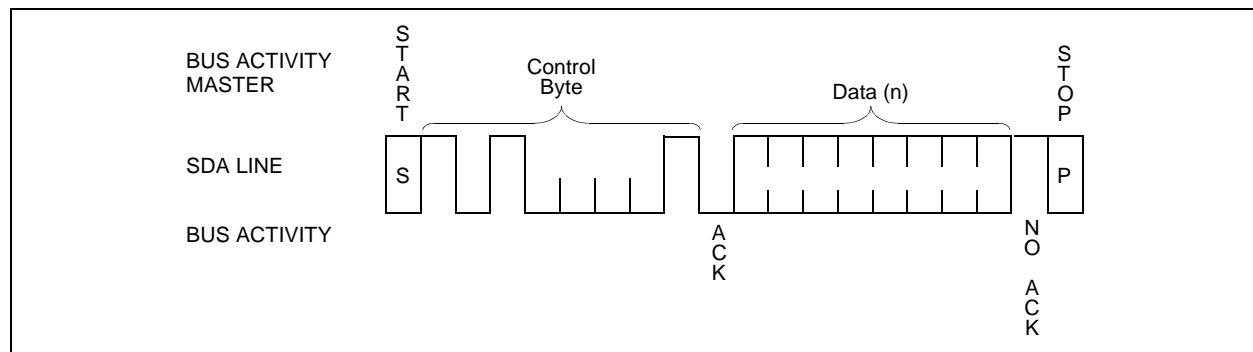

# 24LC21

**FIGURE 7-2: RANDOM READ**

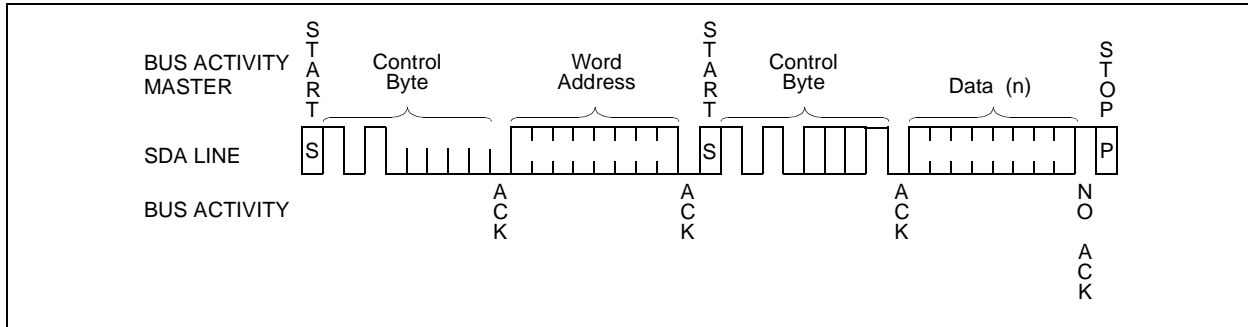

**FIGURE 7-3: SEQUENTIAL READ**

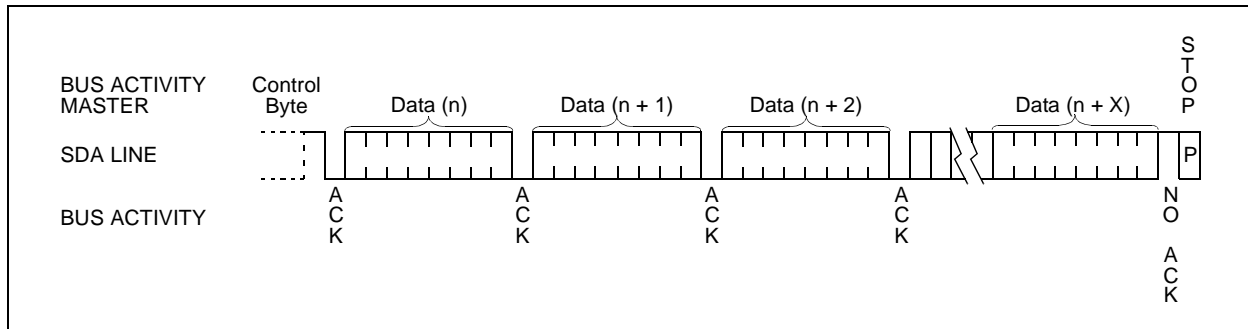

## 8.0 PIN DESCRIPTIONS

**TABLE 8-1: PIN FUNCTION TABLE**

Name	Function
VSS	Ground
SDA	Serial Address/Data I/O
SCL	Serial Clock (Bidirectional mode)
VCLK	Serial Clock (Transmit-only mode)
VCC	+2.5V to 5.5V Power Supply
NC	No Connection

### 8.1 SDA

This pin is used to transfer addresses and data into and out of the device, when the device is in the Bidirectional mode. In the Transmit-only mode, which only allows data to be read from the device, data is also transferred on the SDA pin. This pin is an open drain terminal, therefore the SDA bus requires a pull-up resistor to VCC (typical 10K $\Omega$  for 100 kHz, 2K $\Omega$  for 400 kHz).

For normal data transfer in the Bidirectional mode, SDA is allowed to change only during SCL low. Changes during SCL high are reserved for indicating the Start and Stop conditions.

### 8.2 SCL

This pin is the clock input for the Bidirectional mode, and is used to synchronize data transfer to and from the device. It is also used as the signaling input to switch the device from the Transmit-only mode to the Bidirectional mode. It must remain high for the chip to continue operation in the Transmit-only mode.

### 8.3 VCLK

This pin is the clock input for the Transmit-only mode. In the Transmit-only mode, each bit is clocked out on the rising edge of this signal. In the Bidirectional mode, a high logic level is required on this pin to enable write capability.

# 24LC21

---

## 9.0 PACKAGING INFORMATION

### 9.1 Package Marking Information

8-Lead PDIP



Example

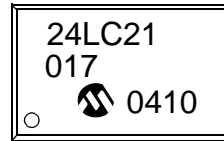

8-Lead SOIC (.150")



Example

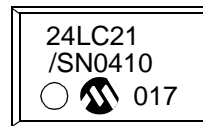

## 8-Lead Plastic Dual In-line (P) – 300 mil Body (PDIP)

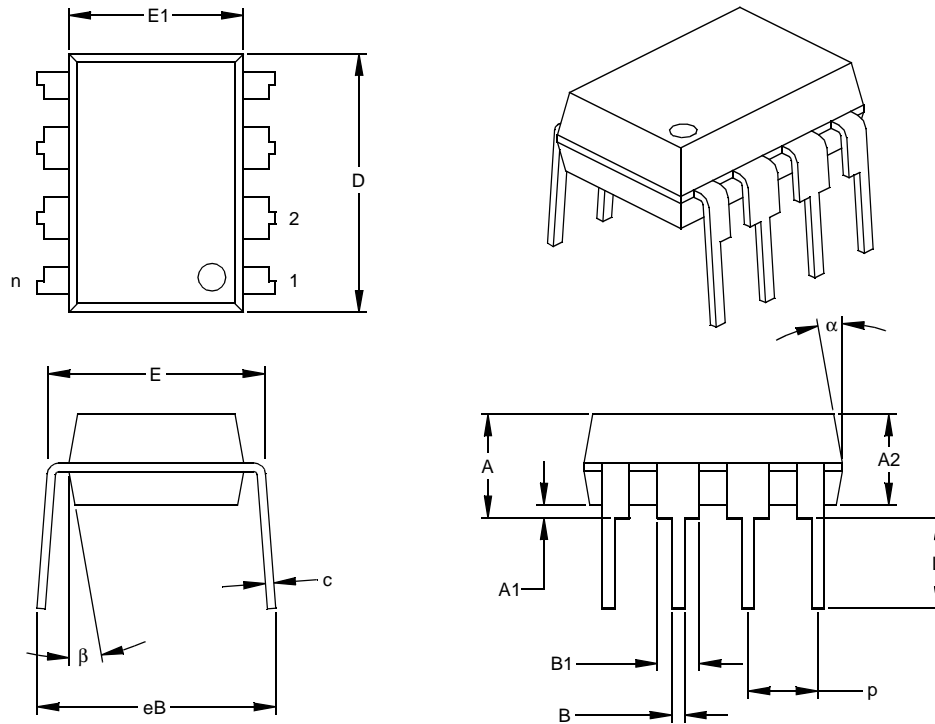

Dimension Limits	Units	INCHES*			MILLIMETERS		
		MIN	NOM	MAX	MIN	NOM	MAX
Number of Pins	n	8			8		
Pitch	p		.100			2.54	
Top to Seating Plane	A	.140	.155	.170	3.56	3.94	4.32
Molded Package Thickness	A2	.115	.130	.145	2.92	3.30	3.68
Base to Seating Plane	A1	.015			0.38		
Shoulder to Shoulder Width	E	.300	.313	.325	7.62	7.94	8.26
Molded Package Width	E1	.240	.250	.260	6.10	6.35	6.60
Overall Length	D	.360	.373	.385	9.14	9.46	9.78
Tip to Seating Plane	L	.125	.130	.135	3.18	3.30	3.43
Lead Thickness	c	.008	.012	.015	0.20	0.29	0.38
Upper Lead Width	B1	.045	.058	.070	1.14	1.46	1.78
Lower Lead Width	B	.014	.018	.022	0.36	0.46	0.56
Overall Row Spacing	§ eB	.310	.370	.430	7.87	9.40	10.92
Mold Draft Angle Top	α	5	10	15	5	10	15
Mold Draft Angle Bottom	β	5	10	15	5	10	15

\* Controlling Parameter

§ Significant Characteristic

**Notes:**

Dimensions D and E1 do not include mold flash or protrusions. Mold flash or protrusions shall not exceed .010" (0.254mm) per side.

JEDEC Equivalent: MS-001

Drawing No. C04-018

# 24LC21

## 8-Lead Plastic Small Outline (SN) – Narrow, 150 mil Body (SOIC)

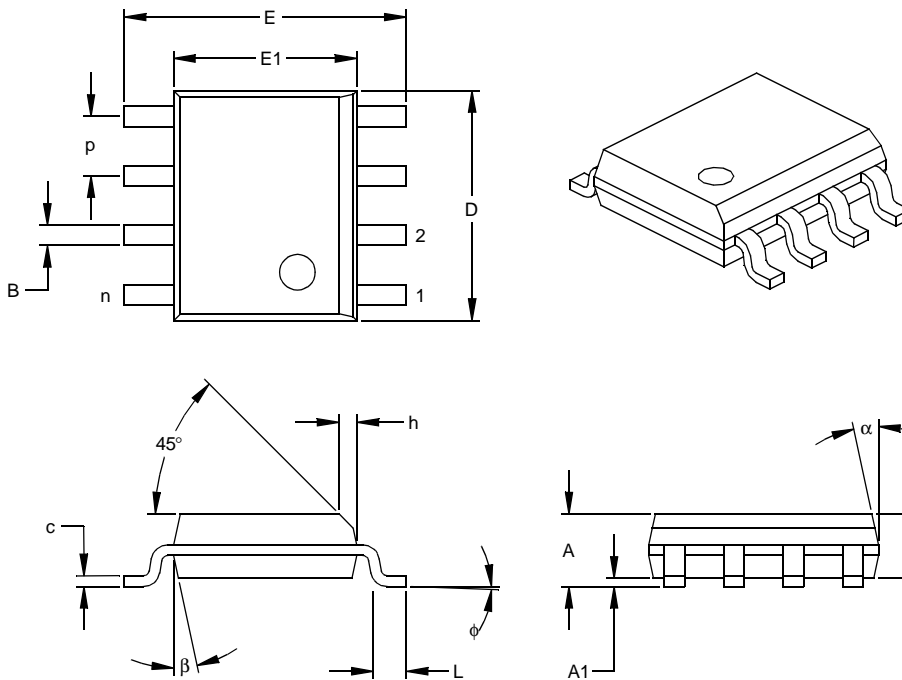

Units		INCHES*			MILLIMETERS		
Dimension	Limits	MIN	NOM	MAX	MIN	NOM	MAX
Number of Pins	n	8			8		
Pitch	p		.050			1.27	
Overall Height	A	.053	.061	.069	1.35	1.55	1.75
Molded Package Thickness	A2	.052	.056	.061	1.32	1.42	1.55
Standoff §	A1	.004	.007	.010	0.10	0.18	0.25
Overall Width	E	.228	.237	.244	5.79	6.02	6.20
Molded Package Width	E1	.146	.154	.157	3.71	3.91	3.99
Overall Length	D	.189	.193	.197	4.80	4.90	5.00
Chamfer Distance	h	.010	.015	.020	0.25	0.38	0.51
Foot Length	L	.019	.025	.030	0.48	0.62	0.76
Foot Angle	φ	0	4	8	0	4	8
Lead Thickness	c	.008	.009	.010	0.20	0.23	0.25
Lead Width	B	.013	.017	.020	0.33	0.42	0.51
Mold Draft Angle Top	α	0	12	15	0	12	15
Mold Draft Angle Bottom	β	0	12	15	0	12	15

\* Controlling Parameter

§ Significant Characteristic

Notes:

Dimensions D and E1 do not include mold flash or protrusions. Mold flash or protrusions shall not exceed .010" (0.254mm) per side.

JEDEC Equivalent: MS-012

Drawing No. C04-057

## APPENDIX A: REVISION HISTORY

### Revision J

Added note to page 1 header (Not recommended for new designs).

Added Section 9.0: Package Marking Information.

Added On-line Support page.

Updated document format.

# 24LC21

---

NOTES:

## ON-LINE SUPPORT

Microchip provides on-line support on the Microchip World Wide Web site.

The web site is used by Microchip as a means to make files and information easily available to customers. To view the site, the user must have access to the Internet and a web browser, such as Netscape® or Microsoft® Internet Explorer. Files are also available for FTP download from our FTP site.

### Connecting to the Microchip Internet Web Site

The Microchip web site is available at the following URL:

**[www.microchip.com](http://www.microchip.com)**

The file transfer site is available by using an FTP service to connect to:

**<ftp://ftp.microchip.com>**

The web site and file transfer site provide a variety of services. Users may download files for the latest Development Tools, Data Sheets, Application Notes, User's Guides, Articles and Sample Programs. A variety of Microchip specific business information is also available, including listings of Microchip sales offices, distributors and factory representatives. Other data available for consideration is:

- Latest Microchip Press Releases
- Technical Support Section with Frequently Asked Questions
- Design Tips
- Device Errata
- Job Postings
- Microchip Consultant Program Member Listing
- Links to other useful web sites related to Microchip Products
- Conferences for products, Development Systems, technical information and more
- Listing of seminars and events

## SYSTEMS INFORMATION AND UPGRADE HOT LINE

The Systems Information and Upgrade Line provides system users a listing of the latest versions of all of Microchip's development systems software products. Plus, this line provides information on how customers can receive the most current upgrade kits. The Hot Line Numbers are:

1-800-755-2345 for U.S. and most of Canada, and

1-480-792-7302 for the rest of the world.

042003

# 24LC21

---

---

## READER RESPONSE

It is our intention to provide you with the best documentation possible to ensure successful use of your Microchip product. If you wish to provide your comments on organization, clarity, subject matter, and ways in which our documentation can better serve you, please FAX your comments to the Technical Publications Manager at (480) 792-4150.

Please list the following information, and use this outline to provide us with your comments about this document.

To: Technical Publications Manager  
RE: Reader Response  
Total Pages Sent \_\_\_\_\_

From: Name \_\_\_\_\_  
Company \_\_\_\_\_  
Address \_\_\_\_\_  
City / State / ZIP / Country \_\_\_\_\_  
Telephone: (\_\_\_\_\_) \_\_\_\_\_ - \_\_\_\_\_ FAX: (\_\_\_\_\_) \_\_\_\_\_ - \_\_\_\_\_

Application (optional):

Would you like a reply? \_\_\_Y \_\_\_N

Device: 24LC21

Literature Number: DS21095J

Questions:

1. What are the best features of this document?

---

---

2. How does this document meet your hardware and software development needs?

---

---

3. Do you find the organization of this document easy to follow? If not, why?

---

---

4. What additions to the document do you think would enhance the structure and subject?

---

---

5. What deletions from the document could be made without affecting the overall usefulness?

---

---

6. Is there any incorrect or misleading information (what and where)?

---

---

7. How would you improve this document?

---

---

## PRODUCT IDENTIFICATION SYSTEM

To order or obtain information, e.g., on pricing or delivery, refer to the factory or the listed sales office.

<u>PART NO.</u>	<u>X</u>	<u>/XX</u>	<u>XXX</u>
Device	Temperature Range	Package	Pattern
Device	24LC21: Dual Mode I <sup>2</sup> C™ Serial EEPROM 24LC21T: Dual Mode I <sup>2</sup> C™ Serial EEPROM (Tape and Reel)		
Temperature Range	Blank = 0°C to +70°C I = -40°C to +85°C		
Package	P = Plastic DIP (300 mil Body), 8-lead SN = Plastic SOIC (150 mil Body), 8-lead		

## Sales and Support

### **Data Sheets**

Products supported by a preliminary Data Sheet may have an errata sheet describing minor operational differences and recommended workarounds. To determine if an errata sheet exists for a particular device, please contact one of the following:

1. Your local Microchip sales office
2. The Microchip Corporate Literature Center U.S. FAX: (480) 792-7277
3. The Microchip Worldwide Site ([www.microchip.com](http://www.microchip.com))

Please specify which device, revision of silicon and Data Sheet (include Literature #) you are using.

### **New Customer Notification System**

Register on our web site ([www.microchip.com/cn](http://www.microchip.com/cn)) to receive the most current information on our products.

# 24LC21

---

NOTES:

---

---

**Note the following details of the code protection feature on Microchip devices:**

- Microchip products meet the specification contained in their particular Microchip Data Sheet.
- Microchip believes that its family of products is one of the most secure families of its kind on the market today, when used in the intended manner and under normal conditions.
- There are dishonest and possibly illegal methods used to breach the code protection feature. All of these methods, to our knowledge, require using the Microchip products in a manner outside the operating specifications contained in Microchip's Data Sheets. Most likely, the person doing so is engaged in theft of intellectual property.
- Microchip is willing to work with the customer who is concerned about the integrity of their code.
- Neither Microchip nor any other semiconductor manufacturer can guarantee the security of their code. Code protection does not mean that we are guaranteeing the product as "unbreakable."

Code protection is constantly evolving. We at Microchip are committed to continuously improving the code protection features of our products. Attempts to break Microchip's code protection feature may be a violation of the Digital Millennium Copyright Act. If such acts allow unauthorized access to your software or other copyrighted work, you may have a right to sue for relief under that Act.

---

Information contained in this publication regarding device applications and the like is intended through suggestion only and may be superseded by updates. It is your responsibility to ensure that your application meets with your specifications. No representation or warranty is given and no liability is assumed by Microchip Technology Incorporated with respect to the accuracy or use of such information, or infringement of patents or other intellectual property rights arising from such use or otherwise. Use of Microchip's products as critical components in life support systems is not authorized except with express written approval by Microchip. No licenses are conveyed, implicitly or otherwise, under any intellectual property rights.

**Trademarks**

The Microchip name and logo, the Microchip logo, Accuron, dsPIC, KEELOQ, microID, MPLAB, PIC, PICmicro, PICSTART, PRO MATE, PowerSmart, rfPIC, and SmartShunt are registered trademarks of Microchip Technology Incorporated in the U.S.A. and other countries.

AmpLab, FilterLab, MXDEV, MXLAB, PICMASTER, SEEVAL, SmartSensor and The Embedded Control Solutions Company are registered trademarks of Microchip Technology Incorporated in the U.S.A.

Analog-for-the-Digital Age, Application Maestro, dsPICDEM, dsPICDEM.net, dsPICworks, ECAN, ECONOMONITOR, FanSense, FlexROM, fuzzyLAB, In-Circuit Serial Programming, ICSP, ICEPIC, Migratable Memory, MPASM, MPLIB, MPLINK, MPSIM, PICkit, PICDEM, PICDEM.net, PICLAB, PICtail, PowerCal, PowerInfo, PowerMate, PowerTool, rLAB, rfPICDEM, Select Mode, Smart Serial, SmartTel and Total Endurance are trademarks of Microchip Technology Incorporated in the U.S.A. and other countries.

SQTP is a service mark of Microchip Technology Incorporated in the U.S.A.

All other trademarks mentioned herein are property of their respective companies.

© 2004, Microchip Technology Incorporated, Printed in the U.S.A., All Rights Reserved.

 Printed on recycled paper.

**QUALITY MANAGEMENT SYSTEM  
CERTIFIED BY DNV  
== ISO/TS 16949:2002 ==**

*Microchip received ISO/TS-16949:2002 quality system certification for its worldwide headquarters, design and wafer fabrication facilities in Chandler and Tempe, Arizona and Mountain View, California in October 2003. The Company's quality system processes and procedures are for its PICmicro® 8-bit MCUs, KEELOQ® code hopping devices, Serial EEPROMs, microperipherals, nonvolatile memory and analog products. In addition, Microchip's quality system for the design and manufacture of development systems is ISO 9001:2000 certified.*



## WORLDWIDE SALES AND SERVICE

### AMERICAS

#### Corporate Office

2355 West Chandler Blvd.  
Chandler, AZ 85224-6199  
Tel: 480-792-7200  
Fax: 480-792-7277  
Technical Support: 480-792-7627  
Web Address: www.microchip.com

#### Atlanta

3780 Mansell Road, Suite 130  
Alpharetta, GA 30022  
Tel: 770-640-0034  
Fax: 770-640-0307

#### Boston

2 Lan Drive, Suite 120  
Westford, MA 01886  
Tel: 978-692-3848  
Fax: 978-692-3821

#### Chicago

333 Pierce Road, Suite 180  
Itasca, IL 60143  
Tel: 630-285-0071  
Fax: 630-285-0075

#### Dallas

4570 Westgrove Drive, Suite 160  
Addison, TX 75001  
Tel: 972-818-7423  
Fax: 972-818-2924

#### Detroit

Tri-Atria Office Building  
32255 Northwestern Highway, Suite 190  
Farmington Hills, MI 48334  
Tel: 248-538-2250  
Fax: 248-538-2260

#### Kokomo

2767 S. Albright Road  
Kokomo, IN 46902  
Tel: 765-864-8360  
Fax: 765-864-8387

#### Los Angeles

18201 Von Karman, Suite 1090  
Irvine, CA 92612  
Tel: 949-263-1888  
Fax: 949-263-1338

#### San Jose

1300 Terra Bella Avenue  
Mountain View, CA 94043  
Tel: 650-215-1444  
Fax: 650-961-0286

#### Toronto

6285 Northam Drive, Suite 108  
Mississauga, Ontario L4V 1X5, Canada  
Tel: 905-673-0699  
Fax: 905-673-6509

### ASIA/PACIFIC

#### Australia

Suite 22, 41 Rawson Street  
Epping 2121, NSW  
Australia  
Tel: 61-2-9868-6733  
Fax: 61-2-9868-6755

#### China - Beijing

Unit 706B  
Wan Tai Bei Hai Bldg.  
No. 6 Chaoyangmen Bei Str.  
Beijing, 100027, China  
Tel: 86-10-85282100  
Fax: 86-10-85282104

#### China - Chengdu

Rm. 2401-2402, 24th Floor,  
Ming Xing Financial Tower  
No. 88 TIDU Street  
Chengdu 610016, China  
Tel: 86-28-86766200  
Fax: 86-28-86766599

#### China - Fuzhou

Unit 28F, World Trade Plaza  
No. 71 Wusi Road  
Fuzhou 350001, China  
Tel: 86-591-7503506  
Fax: 86-591-7503521

#### China - Hong Kong SAR

Unit 901-6, Tower 2, Metroplaza  
223 Hing Fong Road  
Kwai Fong, N.T., Hong Kong  
Tel: 852-2401-1200  
Fax: 852-2401-3431

#### China - Shanghai

Room 701, Bldg. B  
Far East International Plaza  
No. 317 Xian Xia Road  
Shanghai, 200051  
Tel: 86-21-6275-5700  
Fax: 86-21-6275-5060

#### China - Shenzhen

Rm. 1812, 18/F, Building A, United Plaza  
No. 5022 Binhe Road, Futian District  
Shenzhen 518033, China  
Tel: 86-755-82901380  
Fax: 86-755-8295-1393

#### China - Shunde

Room 401, Hongjian Building, No. 2  
Fengxiangnan Road, Ronggui Town, Shunde  
District, Foshan City, Guangdong 528303, China  
Tel: 86-757-28395507 Fax: 86-757-28395571

#### China - Qingdao

Rm. B505A, Fullhope Plaza,  
No. 12 Hong Kong Central Rd.  
Qingdao 266071, China  
Tel: 86-532-5027355 Fax: 86-532-5027205

#### India

Divyasree Chambers  
1 Floor, Wing A (A3/A4)  
No. 11, O'Shaughnessy Road  
Bangalore, 560 025, India  
Tel: 91-80-22290061 Fax: 91-80-22290062

#### Japan

Benex S-1 6F  
3-18-20, Shinyokohama  
Kohoku-Ku, Yokohama-shi  
Kanagawa, 222-0033, Japan  
Tel: 81-45-471- 6166 Fax: 81-45-471-6122

#### Korea

168-1, Youngbo Bldg. 3 Floor  
Samsung-Dong, Kangnam-Ku  
Seoul, Korea 135-882  
Tel: 82-2-554-7200 Fax: 82-2-558-5932 or  
82-2-558-5934

#### Singapore

200 Middle Road  
#07-02 Prime Centre  
Singapore, 188980  
Tel: 65-6334-8870 Fax: 65-6334-8850

#### Taiwan

Kaohsiung Branch  
30F - 1 No. 8  
Min Chuan 2nd Road  
Kaohsiung 806, Taiwan  
Tel: 886-7-536-4818  
Fax: 886-7-536-4803

#### Taiwan

Taiwan Branch  
11F-3, No. 207  
Tung Hua North Road  
Taipei, 105, Taiwan  
Tel: 886-2-2717-7175 Fax: 886-2-2545-0139

### EUROPE

#### Austria

Durisolstrasse 2  
A-4600 Wels  
Austria  
Tel: 43-7242-2244-399  
Fax: 43-7242-2244-393

#### Denmark

Regus Business Centre  
Lautrup høj 1-3  
Ballerup DK-2750 Denmark  
Tel: 45-4420-9895 Fax: 45-4420-9910

#### France

Parc d'Activite du Moulin de Massy  
43 Rue du Saule Trapu  
Batiment A - Ier Etage  
91300 Massy, France  
Tel: 33-1-69-53-63-20  
Fax: 33-1-69-30-90-79

#### Germany

Steinheilstrasse 10  
D-85737 Ismaning, Germany  
Tel: 49-89-627-144-0  
Fax: 49-89-627-144-44

#### Italy

Via Quasimodo, 12  
20025 Legnano (MI)  
Milan, Italy  
Tel: 39-0331-742611  
Fax: 39-0331-466781

#### Netherlands

Waegenburghtplein 4  
NL-5152 JR, Drunen, Netherlands  
Tel: 31-416-690399  
Fax: 31-416-690340

#### United Kingdom

505 Eskdale Road  
Winnersh Triangle  
Wokingham  
Berkshire, England RG41 5TU  
Tel: 44-118-921-5869  
Fax: 44-118-921-5820

05/28/04