

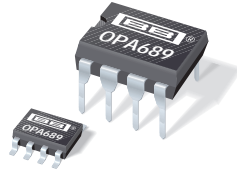

OPA689



For most current data sheet and other product information, visit [www.burr-brown.com](http://www.burr-brown.com)

## Wideband, High Gain VOLTAGE LIMITING AMPLIFIER

### FEATURES

- HIGH LINEARITY NEAR LIMITING
- FAST RECOVERY FROM OVERDRIVE: 2.4ns
- LIMITING VOLTAGE ACCURACY:  $\pm 15\text{mV}$
- $-3\text{dB}$  BANDWIDTH ( $G = +6$ ): 280MHz
- STABLE FOR  $G \geq +4$
- SLEW RATE:  $1600\text{V}/\mu\text{s}$
- $\pm 5\text{V}$  AND  $+5\text{V}$  SUPPLY OPERATION
- LOW GAIN VERSION: OPA688

### APPLICATIONS

- TRANSIMPEDANCE WITH FAST OVERDRIVE RECOVERY
- FAST LIMITING ADC INPUT DRIVER
- LOW PROP DELAY COMPARATOR
- NON-LINEAR ANALOG SIGNAL PROCESSING
- DIFFERENCE AMPLIFIER
- IF LIMITING AMPLIFIER
- AM SIGNAL GENERATION

### DESCRIPTION

The OPA689 is a wideband, voltage feedback op amp that offers bipolar output voltage limiting, and is stable for gains  $\geq +4$ . Two buffered limiting voltages take control of the output when it attempts to drive beyond these limits. This new output limiting architecture holds the limiter offset error to  $\pm 15\text{mV}$ . The op amp operates linearly to within  $30\text{mV}$  of the limits.

The combination of narrow nonlinear range and low limiting offset allows the limiting voltages to be set within  $100\text{mV}$  of the desired linear output range. A fast 2.4ns recovery from limiting ensures that overdrive signals will be transparent to the signal channel. Implementing the

limiting function at the output, as opposed to the input, gives the specified limiting accuracy for any gain, and allows the OPA689 to be used in all standard op amp applications.

Non-linear analog signal processing circuits will benefit from the OPA689's sharp transition from linear operation to output limiting. The quick recovery time supports high speed applications.

The OPA689 is available in an industry-standard pinout in PDIP-8 and SO-8 packages. For lower gain applications requiring output limiting with fast recovery, consider the OPA688.

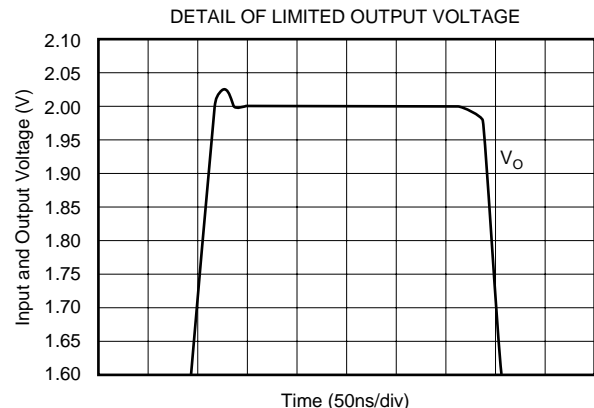
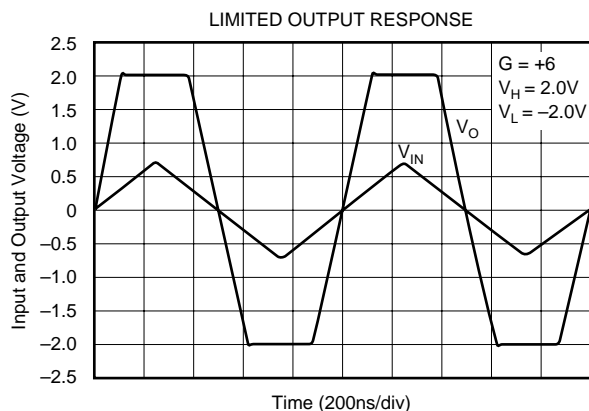

International Airport Industrial Park • Mailing Address: PO Box 11400, Tucson, AZ 85734 • Street Address: 6730 S. Tucson Blvd., Tucson, AZ 85706 • Tel: (520) 746-1111  
Twx: 910-952-1111 • Internet: <http://www.burr-brown.com/> • Cable: BBRCORP • Telex: 066-6491 • FAX: (520) 889-1510 • Immediate Product Info: (800) 548-6132

# SPECIFICATIONS — $V_S = \pm 5V$

G = +6,  $R_L = 500\Omega$ ,  $R_F = 750\Omega$ ,  $V_H = -V_L = 2V$ , (Figure 1 for AC performance only), unless otherwise noted.

PARAMETER	CONDITIONS	OPA689U, P						TEST LEVEL <sup>(2)</sup>
		TYP	GUARANTEED <sup>(1)</sup>				MIN/ MAX	
		+25°C	+25°C	0°C to +70°C	-40°C to +85°C	UNITS		
<b>AC PERFORMANCE (see Fig. 1)</b>								
Small Signal Bandwidth	$V_O < 0.5V_{p-p}$ G = +6	280	220	210	200	MHz	Min	B
	G = +12	90	—	—	—	MHz	Typ	C
	G = -6	220	—	—	—	MHz	Typ	C
Gain Bandwidth Product (G ≥ +20)	$V_O < 0.5V_{p-p}$	720	490	460	430	MHz	Min	B
Gain Peaking	$V_O < 0.5V_{p-p}$ , G = +4	8	—	—	—	dB	Typ	C
0.1dB Gain Flatness Bandwidth	$V_O < 0.5V_{p-p}$	110	—	—	—	MHz	Typ	C
Large Signal Bandwidth	$V_O = 2V_{p-p}$	290	185	175	170	MHz	Min	B
Step Response								
Slew Rate	2V Step	1600	1300	1250	950	V/μs	Min	B
Rise/Fall Time	0.5V Step	1.2	1.8	1.9	2.4	ns	Max	B
Settling Time: 0.05%	2V Step	7	—	—	—	ns	Typ	C
Spurious Free Dynamic Range	f = 5MHz, $V_O = 2V_{p-p}$	61	57	53	48	dB	Min	B
Differential Gain	NTSC, PAL, $R_L = 500\Omega$	0.02	—	—	—	%	Typ	C
Differential Phase	NTSC, PAL, $R_L = 500\Omega$	0.01	—	—	—	°	Typ	C
Input Noise Density								
Voltage Noise	f ≥ 1MHz	4.6	5.3	6.0	6.1	nV/√Hz	Max	B
Current Noise	f ≥ 1MHz	2.0	2.5	2.9	3.6	pA/√Hz	Max	B
<b>DC PERFORMANCE (<math>V_{CM} = 0V</math>)</b>								
Open-Loop Voltage Gain ( $A_{OL}$ )	$V_O = \pm 0.5V$	56	<b>50</b>	48	47	dB	Min	A
Input Offset Voltage		±1	<b>±5</b>	±6	±7	mV	Max	A
Average Drift		—	—	±14	±14	μV/°C	Max	B
Input Bias Current <sup>(3)</sup>		+8	<b>±12</b>	±13	±20	μA	Max	A
Average Drift		—	—	-60	-90	nA/°C	Max	B
Input Offset Current		±0.3	<b>±2</b>	±3	±4	μA	Max	A
Average Drift		—	—	±10	±10	nA/°C	Max	B
<b>INPUT</b>								
Common-Mode Rejection Ratio	Input Referred, $V_{CM} = \pm 0.5V$	60	<b>53</b>	52	50	dB	Min	A
Common-Mode Input Range <sup>(4)</sup>		±3.3	±3.2	±3.2	±3.1	V	Min	A
Input Impedance								
Differential-Mode		0.4    1	—	—	—	MΩ    pF	Typ	C
Common-Mode		1    1	—	—	—	MΩ    pF	Typ	C
<b>OUTPUT</b>								
Output Voltage Range	$V_H = -V_L = 4.3V$ $R_L \geq 500\Omega$	±4.1	<b>±3.9</b>	±3.9	±3.8	V	Min	A
Current Output, Sourcing		105	<b>90</b>	85	80	mA	Min	A
Sinking		-85	<b>-70</b>	-65	-60	mA	Min	A
Closed-Loop Output Impedance	G = +4, f < 100kHz	0.8	—	—	—	Ω	Typ	C
<b>POWER SUPPLY</b>								
Operating Voltage, Specified		±5	—	—	—	V	Typ	C
Maximum		—	<b>±6</b>	±6	±6	V	Max	A
Quiescent Current, Maximum		15.8	<b>17</b>	19	20	mA	Max	A
Minimum		15.8	<b>14</b>	12.8	11	mA	Min	A
Power Supply Rejection Ratio +PSR (Input Referred)	+ $V_S = 4.5V$ to 5.5V	65	<b>58</b>	57	55	dB	Min	A
<b>OUTPUT VOLTAGE LIMITERS</b>								
Default Limit Voltage	Limiter Pins Open	±3.3	<b>±3.0</b>	±3.0	±2.9	V	Min	A
Minimum Limiter Separation ( $V_H - V_L$ )		200	200	200	200	mV	Min	B
Maximum Limit Voltage		—	±4.3	±4.3	±4.3	V	Max	B
Limiter Input Bias Current Magnitude <sup>(5)</sup>	$V_O = 0$							
Maximum		54	<b>65</b>	68	70	μA	Max	A
Minimum		54	<b>35</b>	34	31	μA	Min	A
Average Drift		—	—	40	45	nA/°C	Max	B
Limiter Input Impedance		2    1	—	—	—	MΩ    pF	Typ	C
Limiter Feedthrough <sup>(6)</sup>		-60	—	—	—	dB	Typ	C
DC Performance in Limit Mode								
Limiter Offset Voltage	$V_{IN} = \pm 0.7V$ $(V_O - V_H)$ or $(V_O - V_L)$	±15	<b>±35</b>	±40	±40	mV	Max	A
Op Amp Input Bias Current Shift <sup>(3)</sup>		3	—	—	—	μA	Typ	C

# SPECIFICATIONS — $V_S = \pm 5V$ (cont.)

G = +6,  $R_L = 500\Omega$ ,  $R_F = 750\Omega$ ,  $V_H = -V_L = 2V$ , (Figure 1 for AC performance only), unless otherwise noted.

PARAMETER	CONDITIONS	OPA689U, P						TEST LEVEL <sup>(2)</sup>
		TYP	GUARANTEED <sup>(1)</sup>				MIN/ MAX	
		+25°C	+25°C	0°C to +70°C	-40°C to +85°C	UNITS		
<b>OUTPUT VOLTAGE LIMITERS (CONT)</b>								
AC Performance in Limit Mode								
Limiter Small Signal Bandwidth	$V_{IN} = \pm 0.7V$ , $V_O < 0.02V_{p-p}$	450	—	—	—	MHz	Typ	C
Limiter Slew Rate <sup>(7)</sup>		100	—	—	—	V/ $\mu$ s	Typ	C
Limited Step Response								
Overshoot	$V_{IN} = 0$ to $\pm 0.7V$ Step	250	—	—	—	mV	Typ	C
Recovery Time	$V_{IN} = \pm 0.7V$ to 0 Step	2.4	2.8	3.0	3.2	ns	Max	B
Linearity Guardband <sup>(8)</sup>	$f = 5MHz$ , $V_O = 2V_{p-p}$	30	—	—	—	mV	Typ	C
<b>THERMAL CHARACTERISTICS</b>								
Temperature Range	Specification: P, U	-40 to +85	—	—	—	°C	Typ	C
Thermal Resistance								
P 8-Pin DIP		100	—	—	—	°C/W	Typ	C
U 8-Pin SO-8		125	—	—	—	°C/W	Typ	C

NOTES: (1) Junction Temperature = Ambient Temperature for low temperature limit and 25°C guaranteed specifications. Junction Temperature = Ambient Temperature + 23°C at high temperature limit guaranteed specifications. (2) TEST LEVELS: (A) 100% tested at 25°C. Over temperature limits by characterization and simulation. (B) Limits set by characterization and simulation. (C) Typical value for information only. (3) Current is considered positive out of node. (4) CMIR tested as < 3dB degradation from minimum CMRR at specified limits. (5)  $I_{VH}$  ( $V_H$  bias current) is positive, and  $I_{VL}$  ( $V_L$  bias current) is negative, under these conditions. See Note 3 and Figures 1 and 7. (6) Limiter feedthrough is the ratio of the output magnitude to the sinewave added to  $V_H$  (or  $V_L$ ) when  $V_{IN} = 0$ . (7)  $V_H$  slew rate conditions are:  $V_{IN} = +0.7V$ ,  $G = +6$ ,  $V_L = -2V$ ,  $V_H =$  step between 2V and 0V.  $V_L$  slew rate conditions are similar. (8) Linearity Guardband is defined for an output sinusoid ( $f = 1MHz$ ,  $V_O = 2V_{pp}$ ) centered between the limiter levels ( $V_H$  and  $V_L$ ). It is the difference between the limiter level and the peak output voltage where SFDR decreases by 3dB (see Figure 8).

The information provided herein is believed to be reliable; however, BURR-BROWN assumes no responsibility for inaccuracies or omissions. BURR-BROWN assumes no responsibility for the use of this information, and all use of such information shall be entirely at the user's own risk. Prices and specifications are subject to change without notice. No patent rights or licenses to any of the circuits described herein are implied or granted to any third party. BURR-BROWN does not authorize or warrant any BURR-BROWN product for use in life support devices and/or systems.

# SPECIFICATIONS — $V_S = +5V$

$G = +6$ ,  $R_F = 750\Omega$ ,  $R_L = 500\Omega$  tied to  $V_{CM} = 2.5V$ ,  $V_L = V_{CM} - 1.2V$ ,  $V_H = V_{CM} + 1.2V$ , (Figure 2 for AC performance only), unless otherwise noted.

PARAMETER	CONDITIONS	OPA689U, P						TEST LEVEL <sup>(2)</sup>
		TYP	GUARANTEED <sup>(1)</sup>				MIN/ MAX	
		+25°C	+25°C	0°C to +70°C	-40°C to +85°C	UNITS		
<b>AC PERFORMANCE (see Fig. 2)</b>								
Small Signal Bandwidth	$V_O < 0.5V_{p-p}$ $G = +6$	210	180	160	150	MHz	Min	B
	$G = +12$	70	—	—	—	MHz	Typ	C
	$G = -6$	180	—	—	—	MHz	Typ	C
Gain Bandwidth Product ( $G \geq +20$ )	$V_O < 0.5V_{p-p}$	440	330	310	300	MHz	Min	B
Gain Peaking	$V_O < 0.5V_{p-p}$ , $G = +4$	4	—	—	—	dB	Typ	B
0.1dB Gain Flatness Bandwidth	$V_O < 0.5V_{p-p}$	35	—	—	—	MHz	Typ	C
Large Signal Bandwidth	$V_O = 2V_{p-p}$	175	150	140	125	MHz	Min	B
Step Response								
Slew Rate	2V Step	1600	1300	1250	950	V/ $\mu$ s	Min	B
Rise/Fall Time	0.5V Step	1.9	2.1	2.2	2.6	ns	Max	B
Settling Time: 0.05%	2V Step	7	—	—	—	ns	Typ	C
Spurious Free Dynamic Range	$f = 5MHz$ , $V_O = 2V_{p-p}$	59	55	51	46	dB	Min	B
Input Noise								
Voltage Noise Density	$f \geq 1MHz$	4.6	5.3	6.0	6.1	nV/ $\sqrt{Hz}$	Max	B
Current Noise Density	$f \geq 1MHz$	2.0	2.5	2.9	3.6	pA/ $\sqrt{Hz}$	Max	B
<b>DC PERFORMANCE</b>								
Open-Loop Voltage Gain ( $A_{OL}$ )	$V_O = \pm 0.5V$	56	<b>50</b>	48	47	dB	Min	A
Input Offset Voltage		$\pm 1$	$\pm 5$	$\pm 6$	$\pm 8$	mV	Max	A
Average Drift		—	—	$\pm 14$	$\pm 14$	$\mu V/^\circ C$	Max	B
Input Bias Current <sup>(3)</sup>		+8	$\pm 12$	$\pm 13$	$\pm 20$	$\mu A$	Max	A
Average Drift		—	—	-60	-90	nA/ $^\circ C$	Max	B
Input Offset Current		$\pm 0.3$	$\pm 2$	$\pm 3$	$\pm 4$	$\mu A$	Max	A
Average Drift		—	—	$\pm 10$	$\pm 10$	nA/ $^\circ C$	Max	B
<b>INPUT</b>								
Common-Mode Rejection Ratio	Input Referred, $V_{CM} \pm 0.5V$	58	<b>51</b>	50	48	dB	Min	A
Common-Mode Input Range <sup>(4)</sup>		$V_{CM} \pm 0.8$	$V_{CM} \pm 0.7$	$V_{CM} \pm 0.7$	$V_{CM} \pm 0.6$	V	Min	A
Input Impedance								
Differential-Mode		0.4    1	—	—	—	M $\Omega$    pF	Typ	C
Common-Mode		1    1	—	—	—	M $\Omega$    pF	Typ	C
<b>OUTPUT</b>								
Output Voltage Range	$V_H = V_{CM} + 1.8V$ , $V_L = V_{CM} - 1.8V$ $R_L \geq 500\Omega$	$V_{CM} \pm 1.6$	<b><math>V_{CM} \pm 1.4</math></b>	$V_{CM} \pm 1.4$	$V_{CM} \pm 1.3$	V	Min	A
Current Output, Sourcing		70	<b>60</b>	55	50	mA	Min	A
Sinking		-60	<b>-50</b>	-45	-40	mA	Min	A
Closed-Loop Output Impedance	$G = +4$ , $f < 100kHz$	0.8	—	—	—	$\Omega$	Typ	C
<b>POWER SUPPLY</b>								
Operating Voltage, Specified		5	—	—	—	V	Typ	C
Maximum		—	12	12	12	V	Max	A
Quiescent Current, Maximum		13	<b>15</b>	15	16	mA	Max	A
Minimum		13	<b>11</b>	10	9	mA	Min	A
Power Supply Rejection Ratio +PSR (Input Referred)	$V_S = 4.5V$ to $5.5V$	65	—	—	—	dB	Typ	C
<b>OUTPUT VOLTAGE LIMITERS</b>								
Default Limiter Voltage	Limiter Pins Open	$V_{CM} \pm 0.9$	<b><math>V_{CM} \pm 0.6</math></b>	$V_{CM} \pm 0.6$	$V_{CM} \pm 0.6$	V	Min	A
Minimum Limiter Separation ( $V_H - V_L$ )		200	200	200	200	mV	Min	B
Maximum Limit Voltage		—	$V_{CM} \pm 1.8$	$V_{CM} \pm 1.8$	$V_{CM} \pm 1.8$	V	Max	B
Limiter Input Bias Current Magnitude <sup>(5)</sup>	$V_O = 2.5V$							
Maximum		35	<b>65</b>	75	85	$\mu A$	Max	A
Minimum		35	<b>0</b>	0	0	$\mu A$	Min	A
Average Drift		—	—	30	50	nA/ $^\circ C$	Max	B
Limiter Input Impedance		2    1	—	—	—	M $\Omega$    pF	Typ	C
Limiter Isolation <sup>(6)</sup>	$f = 5MHz$	-60	—	—	—	dB	Typ	C
DC Performance in Limit Mode								
Limiter Voltage Accuracy	$V_{IN} = V_{CM} \pm 0.4V$ ( $V_O - V_H$ ) or ( $V_O - V_L$ )	$\pm 15$	<b><math>\pm 35</math></b>	$\pm 40$	$\pm 40$	mV	Max	A
Op Amp Bias Current Shift <sup>(3)</sup>		5	—	—	—	$\mu A$	Typ	C
AC Performance in Limit Mode								
Limiter Small Signal Bandwidth	$V_{IN} = \pm 0.4V$ , $V_O < 0.02V_{p-p}$	300	—	—	—	MHz	Typ	C
Limiter Slew Rate <sup>(7)</sup>		20	—	—	—	V/ $\mu$ s	Typ	C
Limited Step Response								
Overshoot	$V_{IN} = V_{CM}$ to $V_{CM} \pm 0.4V$ Step	55	—	—	—	mV	Typ	C
Recovery Time	$V_{IN} = V_{CM} \pm 0.4V$ to $V_{CM}$ Step	15	—	—	—	ns	Typ	C
Linearity Guardband <sup>(8)</sup>	$f = 5MHz$ , $V_O = 2V_{p-p}$	30	—	—	—	mV	Typ	C

# SPECIFICATIONS — $V_S = +5V$ (cont.)

$G = +6$ ,  $R_F = 750\Omega$ ,  $R_L = 500\Omega$  tied to  $V_{CM} = 2.5V$ ,  $V_L = V_{CM} - 1.2V$ ,  $V_H = V_{CM} + 1.2V$ , (Figure 2 for AC performance only), unless otherwise noted.

PARAMETER	CONDITIONS	OPA689U, P						TEST LEVEL <sup>(2)</sup>
		TYP	GUARANTEED <sup>(1)</sup>				MIN/ MAX	
		+25°C	+25°C	0°C to +70°C	-40°C to +85°C	UNITS		
<b>THERMAL CHARACTERISTICS</b>								
Temperature Range	Specification: P, U	-40 to +85	—	—	—	°C	Typ	C
Thermal Resistance								
P 8-Pin DIP		100	—	—	—	°C/W	Typ	C
U 8-Pin SO-8		125	—	—	—	°C/W	Typ	C

NOTES: (1) Junction Temperature = Ambient Temperature for low temperature limit and 25°C guaranteed specifications. Junction Temperature = Ambient Temperature + 23°C at high temperature limit guaranteed specifications. (2) TEST LEVELS: (A) 100% tested at 25°C. Over temperature limits by characterization and simulation. (B) Limits set by characterization and simulation. (C) Typical value for information only. (3) Current is considered positive out of node. (4) CMIR tested as < 3dB degradation from minimum CMRR at specified limits. (5)  $I_{VH}$  ( $V_H$  bias current) is negative, and  $I_{VL}$  ( $V_L$  bias current) is positive, under these conditions. See Note 3 and Figures 2 and 7. (6) Limiter feedthrough is the ratio of the output magnitude to the sinewave added to  $V_H$  (or  $V_L$ ) when  $V_{IN} = 0$ . (7)  $V_H$  slew rate conditions are:  $V_{IN} = V_{CM} + 0.4V$ ,  $G = +6$ ,  $V_L = V_{CM} - 1.2V$ ,  $V_H = \text{step between } V_{CM} + 1.2V \text{ and } V_{CM}$ .  $V_L$  slew rate conditions are similar. (8) Linearity Guardband is defined for an output sinusoid ( $f = 5\text{MHz}$ ,  $V_O = V_{CM} \pm 1V_{p-p}$ ) centered between the limiter levels ( $V_H$  and  $V_L$ ). It is the difference between the limiter level and the peak output voltage where SFDR decreases by 3dB (see Figure 8).

## ABSOLUTE MAXIMUM RATINGS

Supply Voltage .....	$\pm 6.5V$
Internal Power Dissipation .....	See Thermal Characteristics
Input Voltage Range .....	$\pm V_S$
Differential Input Voltage .....	$\pm V_S$
Limiter Voltage Range .....	$\pm(V_S - 0.7V)$
Storage Temperature Range: P, U .....	-40°C to +125°C
Lead Temperature (DIP, soldering, 10s) .....	+300°C
(SO-8, soldering, 3s) .....	+260°C
Junction Temperature .....	+175°C



## ELECTROSTATIC DISCHARGE SENSITIVITY

This integrated circuit can be damaged by ESD. Burr-Brown recommends that all integrated circuits be handled with appropriate precautions. Failure to observe proper handling and installation procedures can cause damage.

ESD damage can range from subtle performance degradation to complete device failure. Precision integrated circuits may be more susceptible to damage because very small parametric changes could cause the device not to meet its published specifications.

## ABSOLUTE MAXIMUM RATINGS

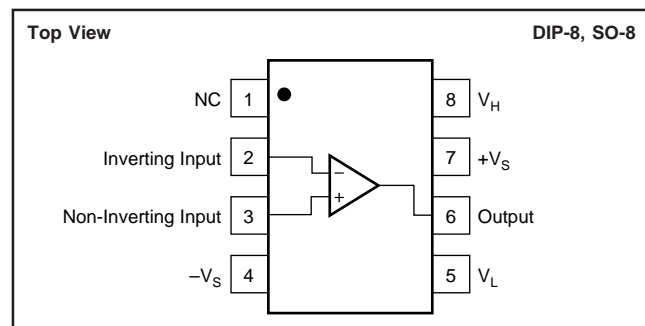

## PACKAGE/ORDERING INFORMATION

PRODUCT	PACKAGE	PACKAGE DRAWING NUMBER	SPECIFIED TEMPERATURE RANGE	PACKAGE MARKING	ORDERING NUMBER <sup>(1)</sup>	TRANSPORT MEDIA
OPA689P	DIP-8	006	-40°C to +85°C	OPA689P	OPA689P	Rails
OPA689U	SO-8 Surface Mount	182	-40°C to +85°C	OPA689U	OPA689U	Rails
"	"	"	"	"	OPA689U/2K5	Tape and Reel

NOTES: (1) Models with a slash (/) are available only in Tape and Reel in the quantities indicated (e.g., /2K5 indicates 2500 devices per reel). Ordering 2500 pieces of "OPA689U/2K5" will get a single 2500-piece Tape and Reel.

# TYPICAL PERFORMANCE CURVES— $V_S = \pm 5V$

$G = +6$ ,  $R_L = 500\Omega$ ,  $R_F = 750\Omega$ ,  $V_H = -V_L = 2V$ , (Figure 1 for AC performance only), unless otherwise noted.

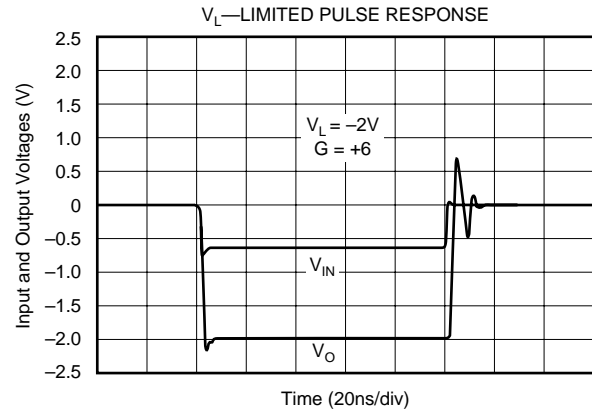
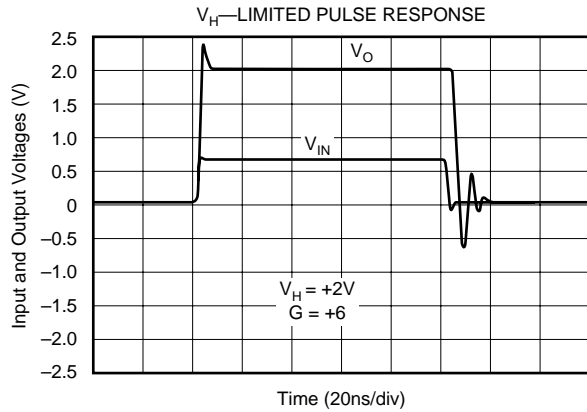
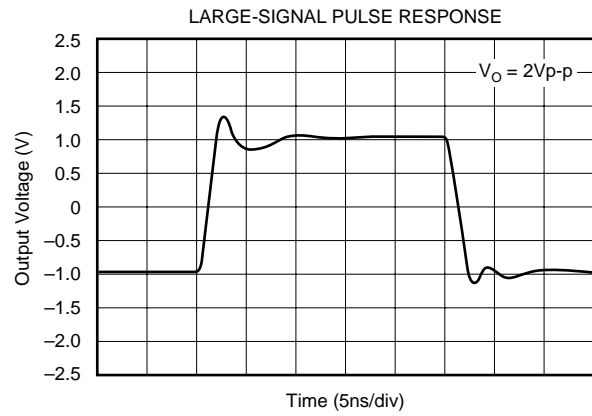
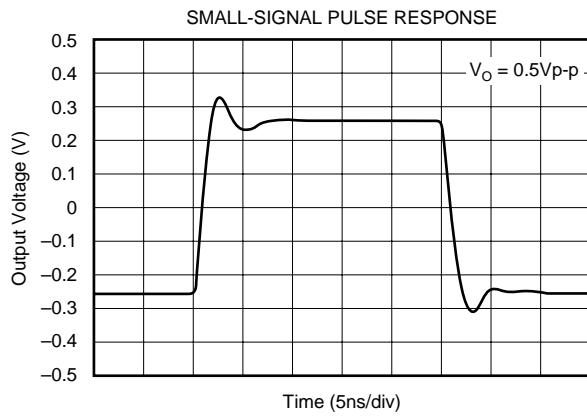
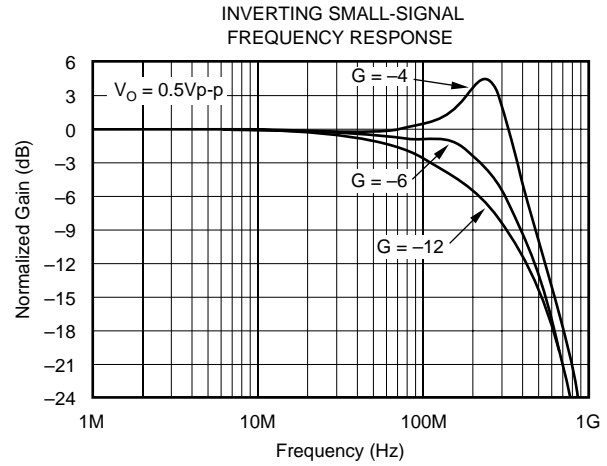
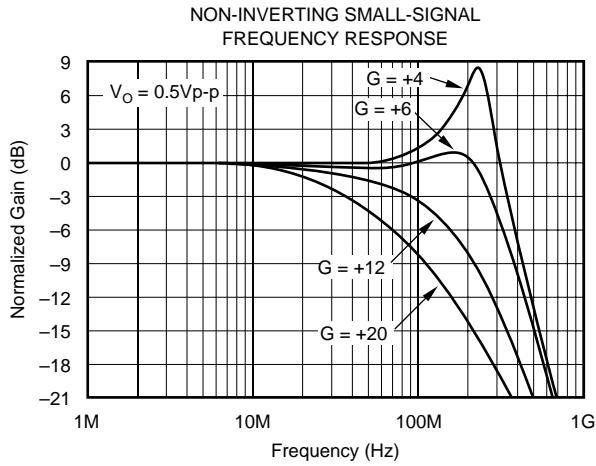

# TYPICAL PERFORMANCE CURVES— $V_S = \pm 5V$ (cont.)

$G = +6$ ,  $R_L = 500\Omega$ ,  $R_F = 750\Omega$ ,  $V_H = -V_L = 2V$ , (Figure 1 for AC performance only), unless otherwise noted.

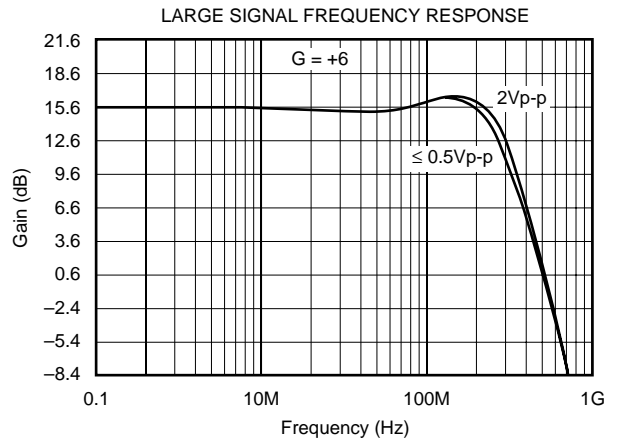
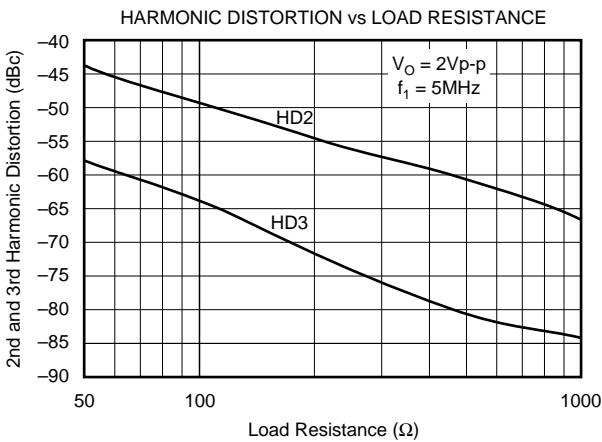
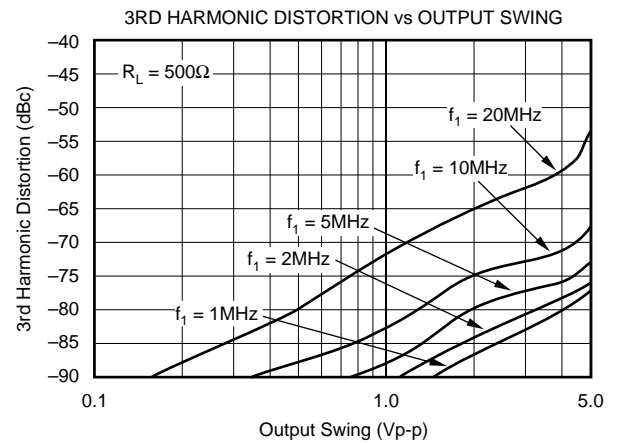
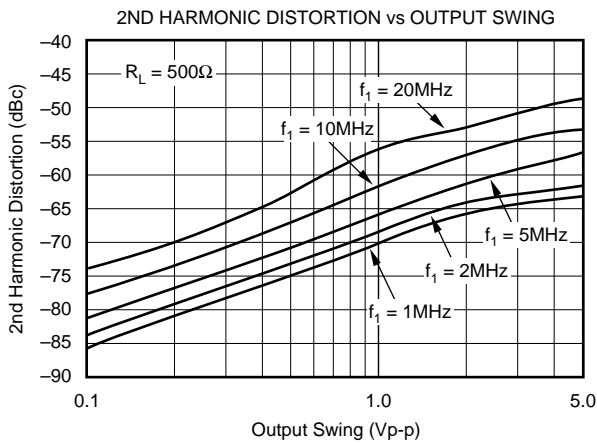
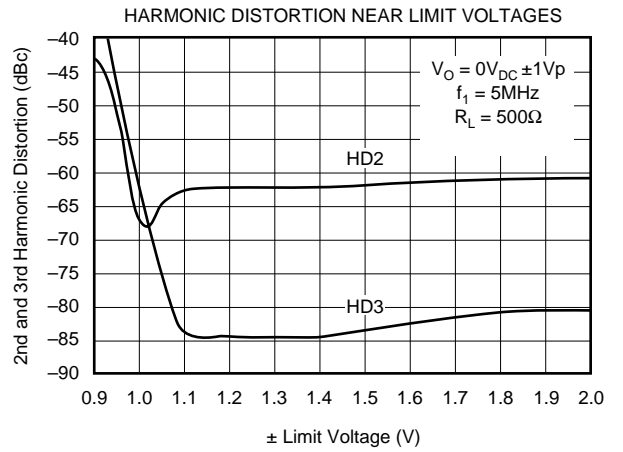
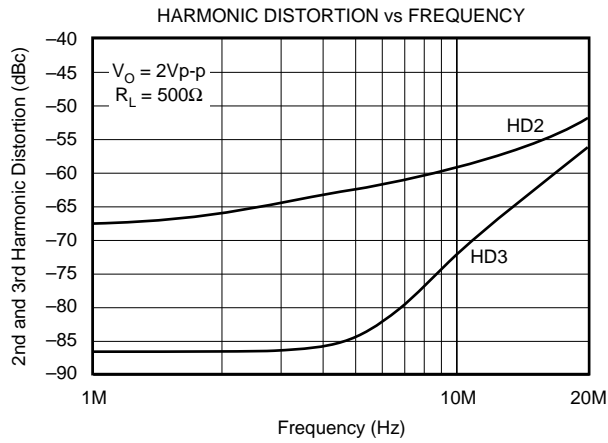

# TYPICAL PERFORMANCE CURVES— $V_S = \pm 5V$ (cont.)

$G = +6$ ,  $R_L = 500\Omega$ ,  $R_F = 750\Omega$ ,  $V_H = -V_L = 2V$ , (Figure 1 for AC performance only), unless otherwise noted.

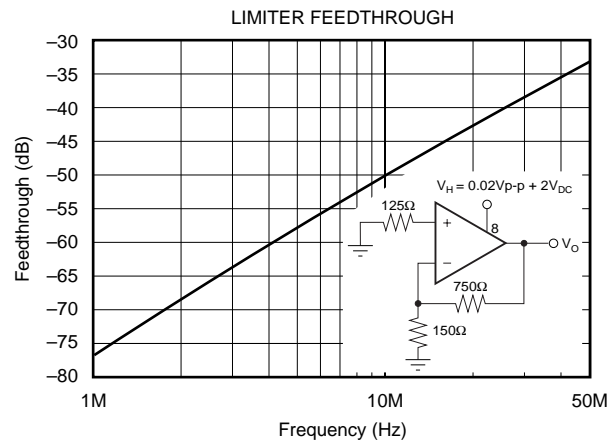
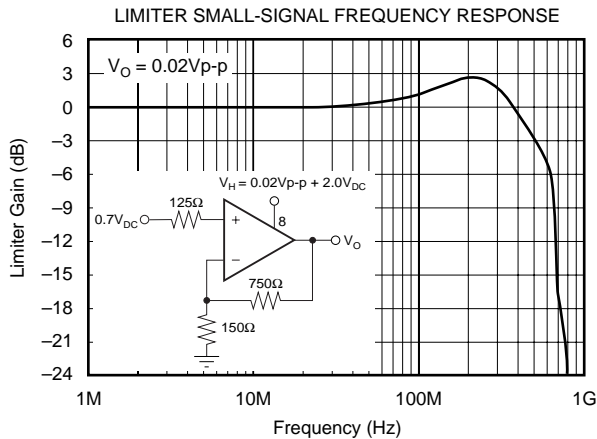
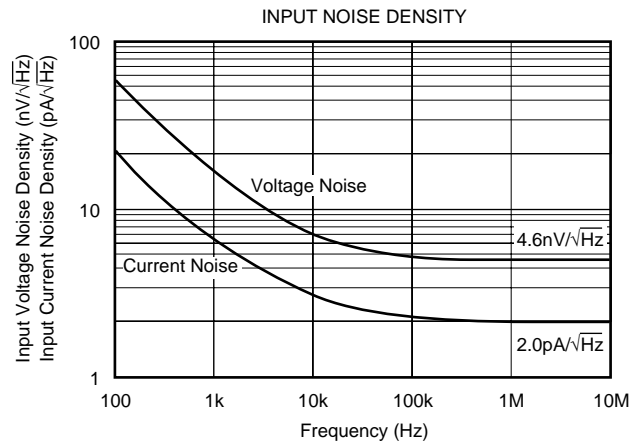
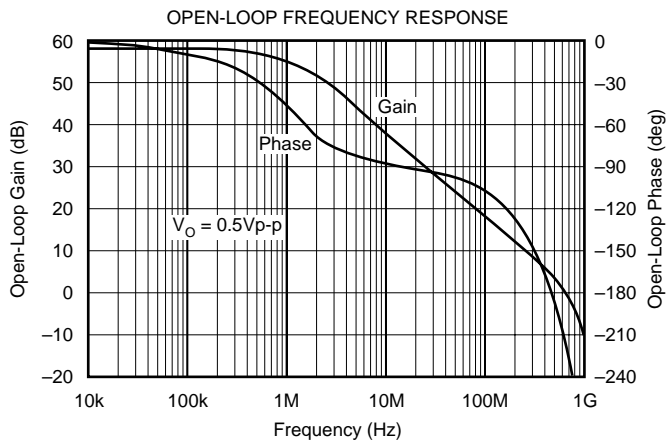
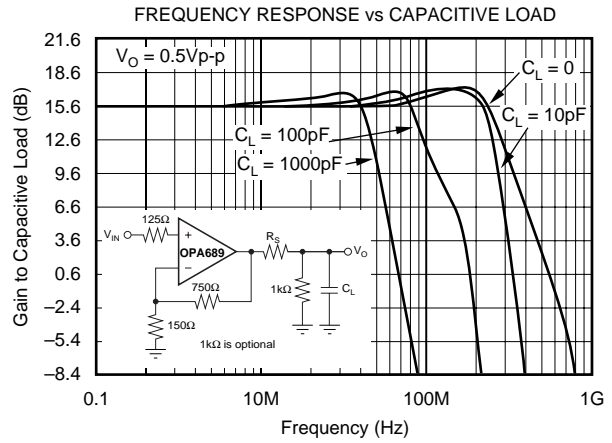
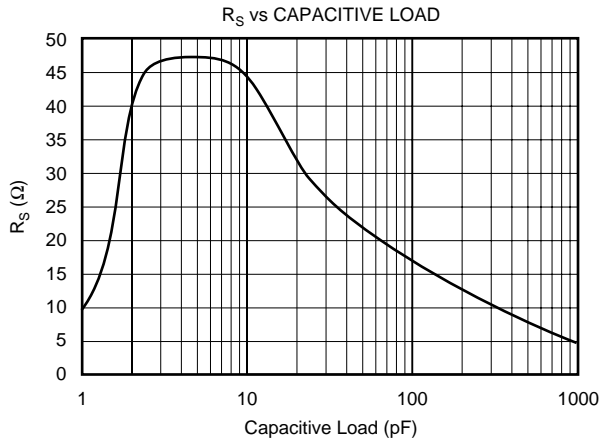

# TYPICAL PERFORMANCE CURVES— $V_S = \pm 5V$ (cont.)

$G = +6$ ,  $R_L = 500\Omega$ ,  $R_F = 750\Omega$ ,  $V_H = -V_L = 2V$ , (Figure 1 for AC performance only), unless otherwise noted.

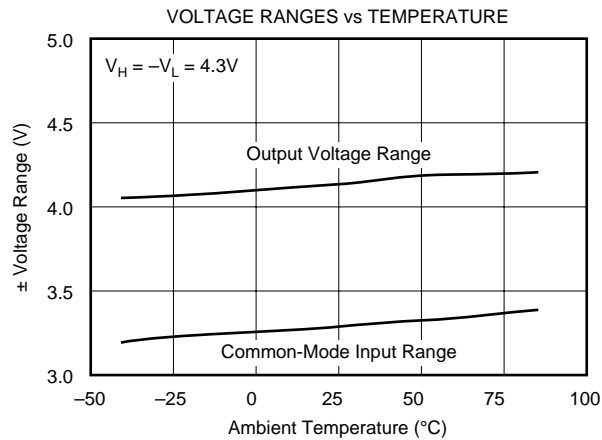
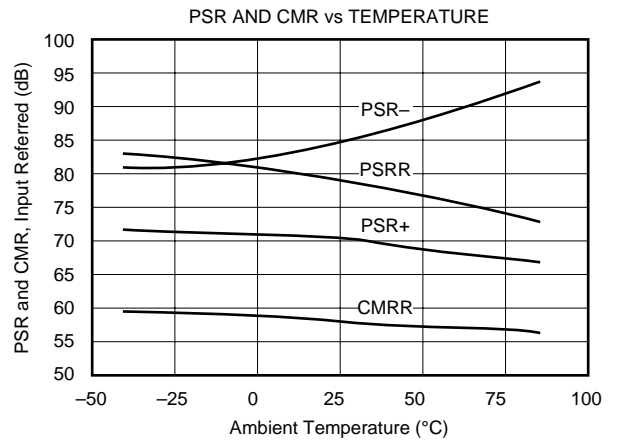
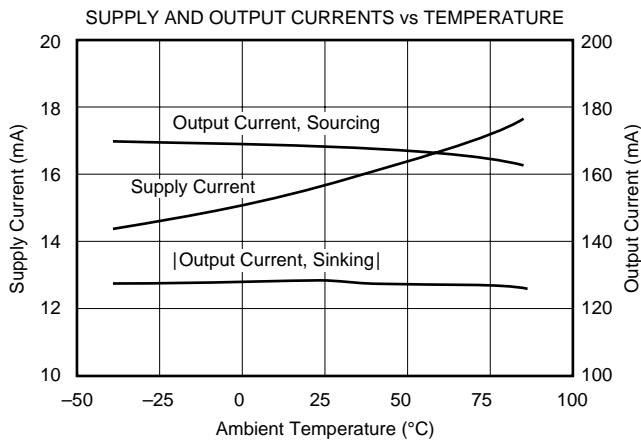
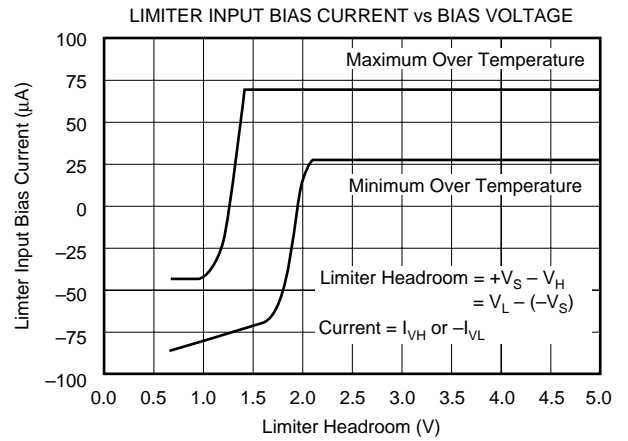
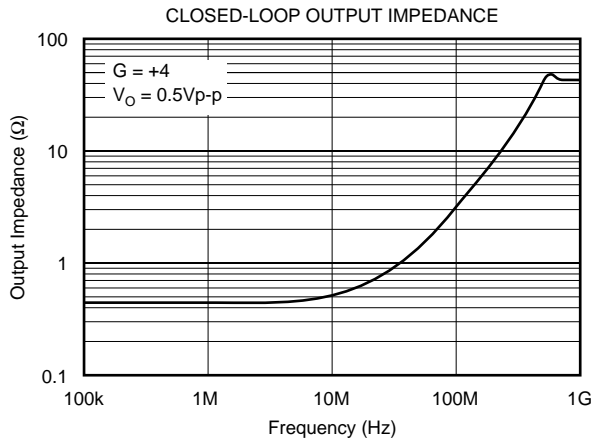

# TYPICAL PERFORMANCE CURVES— $V_S = +5V$

$G = +6$ ,  $R_F = 402\Omega$ ,  $R_L = 500\Omega$  tied to  $V_{CM} = 2.5V$ ,  $V_L = V_{CM} - 1.2V$ ,  $V_H = V_{CM} + 1.2V$ , (Figure 2 for AC performance only), unless otherwise noted.

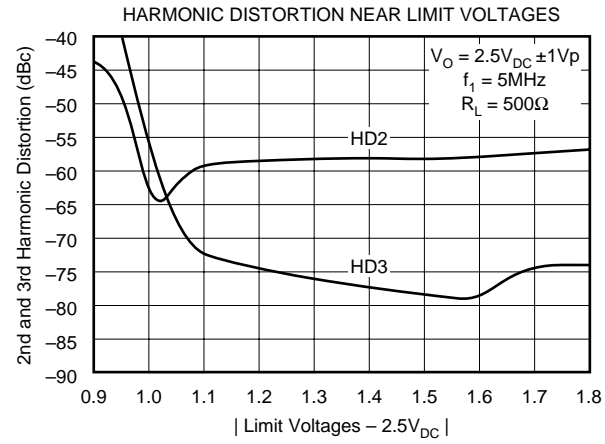
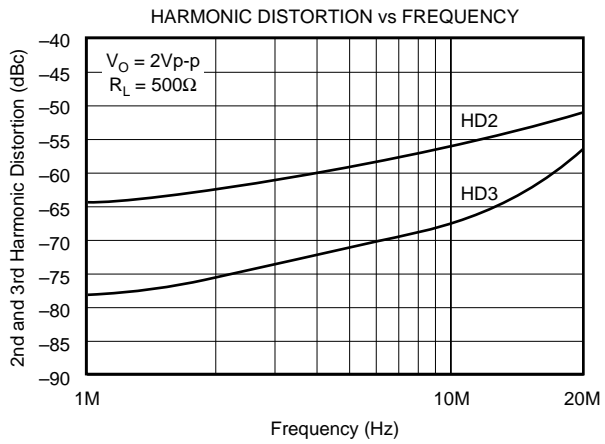
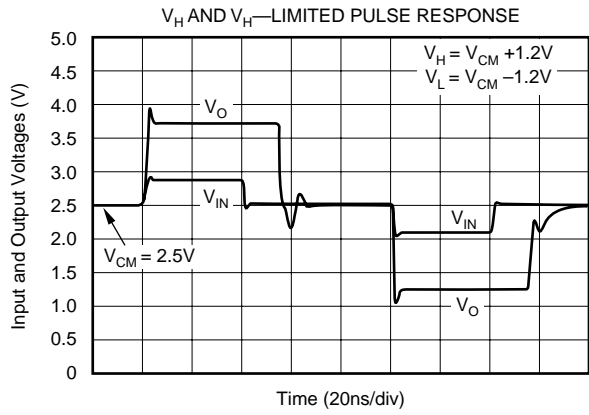
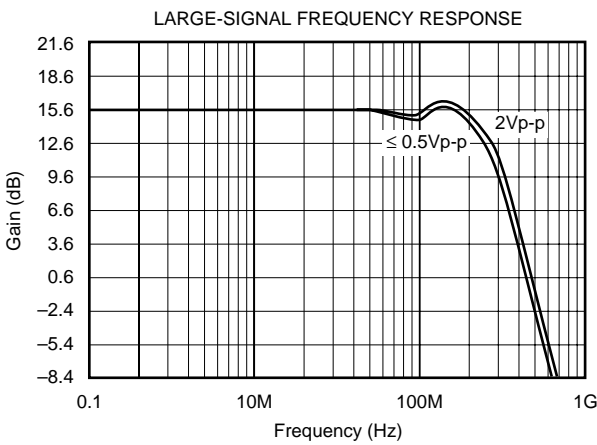
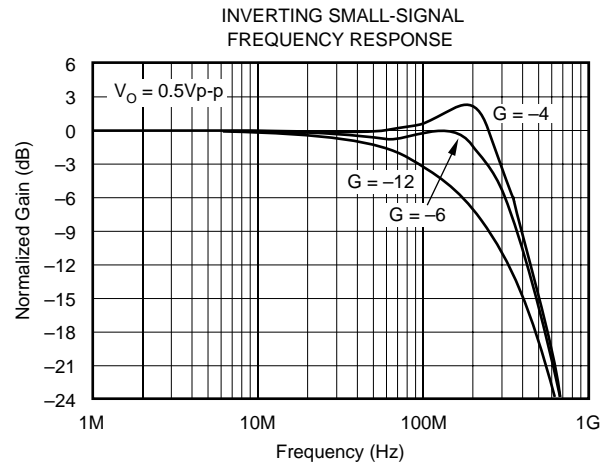
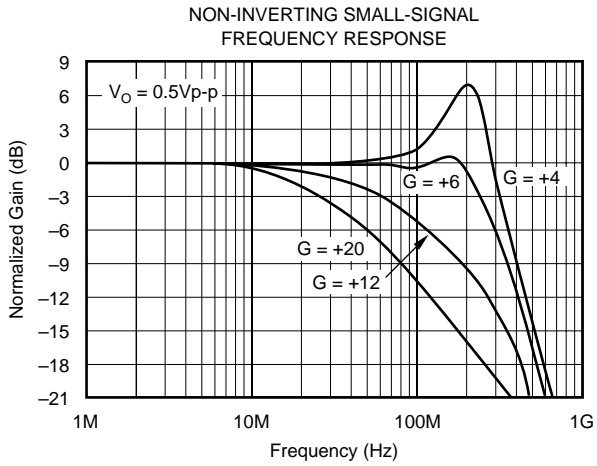

# TYPICAL APPLICATIONS

## DUAL SUPPLY, NON-INVERTING AMPLIFIER

Figure 1 shows a non-inverting gain amplifier for dual supply operation. This circuit was used for AC characterization of the OPA689, with a 50Ω source, which it matches, and a 500Ω load. The power supply bypass capacitors are shown explicitly in Figures 1 and 2, but will be assumed in the other figures. The limiter voltages ( $V_H$  and  $V_L$ ) and their bias currents ( $I_{VH}$  and  $I_{VL}$ ) have the polarities shown.

## SINGLE SUPPLY, NON-INVERTING AMPLIFIER

Figure 2 shows an AC coupled, non-inverting gain amplifier for single supply operation. This circuit was used for AC

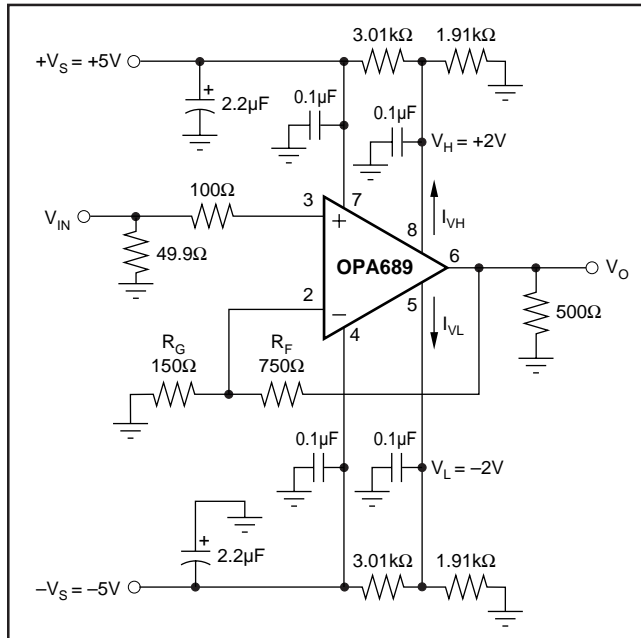

FIGURE 1. DC-Coupled, Dual Supply Amplifier.

characterization of the OPA689, with a 50Ω source, which it matches, and a 500Ω load. The power supply bypass capacitors are shown explicitly in Figures 1 and 2, but will be assumed in the other figures. The limiter voltages ( $V_H$  and  $V_L$ ) and their bias currents ( $I_{VH}$  and  $I_{VL}$ ) have the polarities shown. Notice that the single supply circuit can use 3 resistors to set  $V_H$  and  $V_L$ , where the dual supply circuit usually uses 4 to reference the limit voltages to ground.

## LOW DISTORTION, ADC INPUT DRIVER

The circuit in Figure 3 shows an inverting, low distortion ADC driver that operates on single supply. The converter's internal references bias the op amp input. The 4.0pF and 18pF capacitors form a compensation network that allows

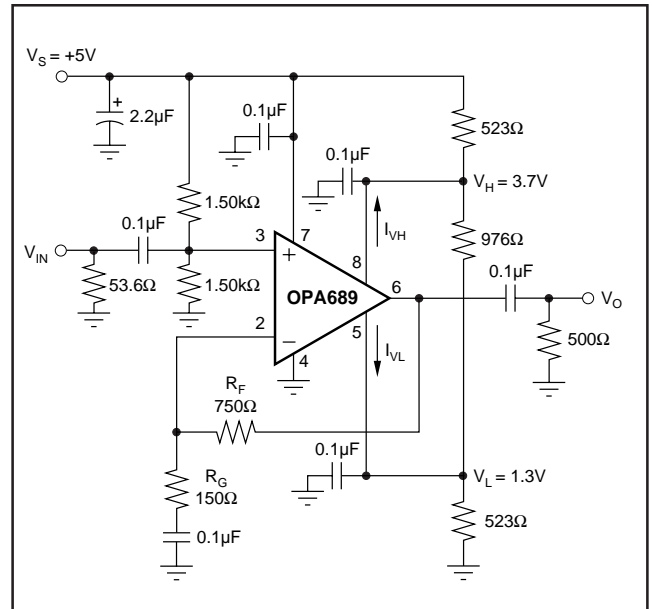

FIGURE 2. AC-Coupled, Single Supply Amplifier.

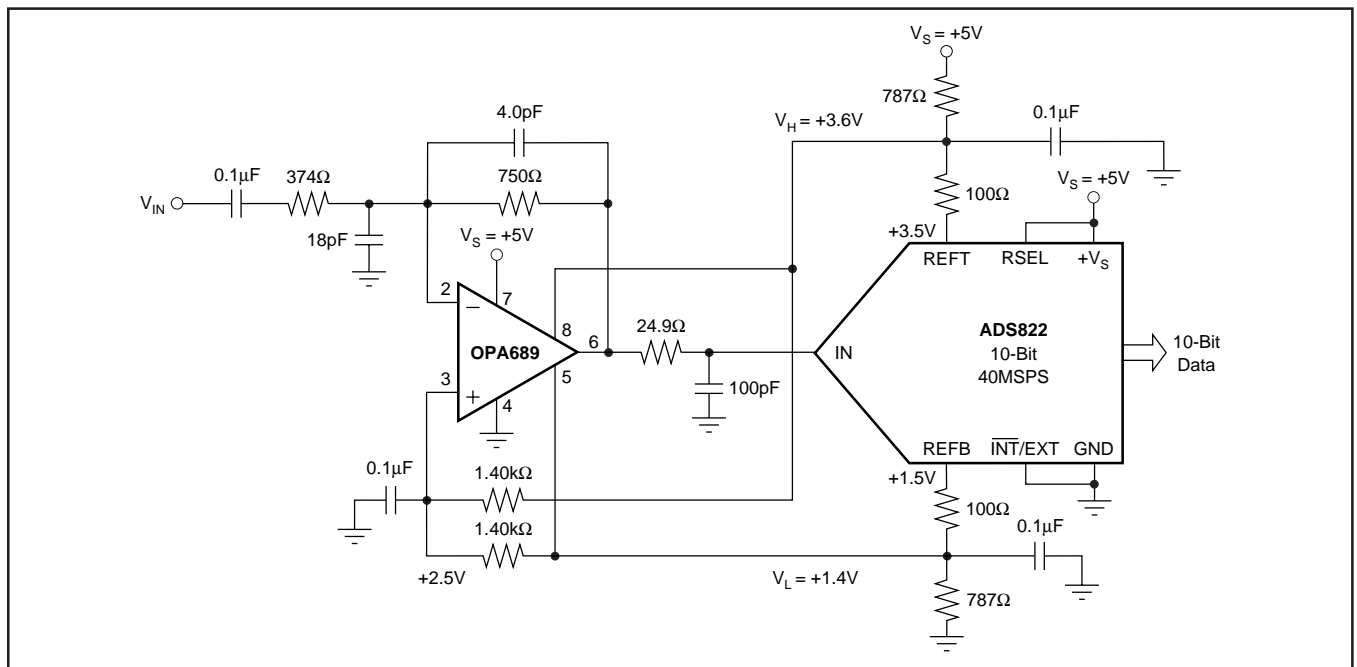

FIGURE 3. Low Distortion, Limiting ADC Input Driver.

the OPA689 to have a flat frequency response at a gain of -2. This increases the loop gain of the op amp feedback network, which reduces the distortion products below their specified values.

### PRECISION HALF WAVE RECTIFIER

Figure 4 shows a half wave rectifier with outstanding precision and speed.  $V_H$  will default to a voltage between 3.1 and 3.8V if left open, while the negative limit is set to ground.

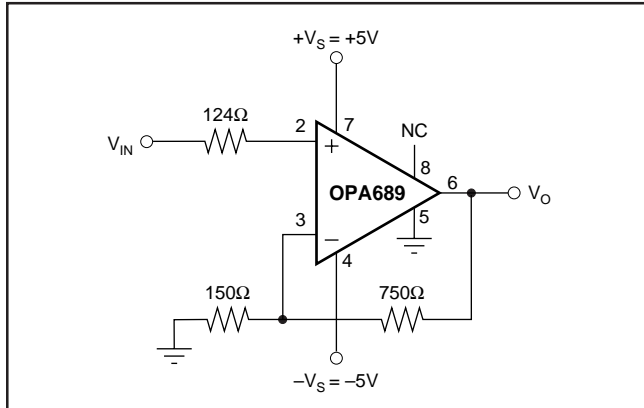

FIGURE 4. Precision Half Wave Rectifier.

### VERY HIGH SPEED COMPARATOR

Figure 5 shows a very high speed comparator with hysteresis. The output level are precisely defined, and the recovery time is exceptional. The output voltage swings between 0.5V and 3.5V to provide a logic level output that switches as  $V_{IN}$  crosses  $V_{REF}$ .

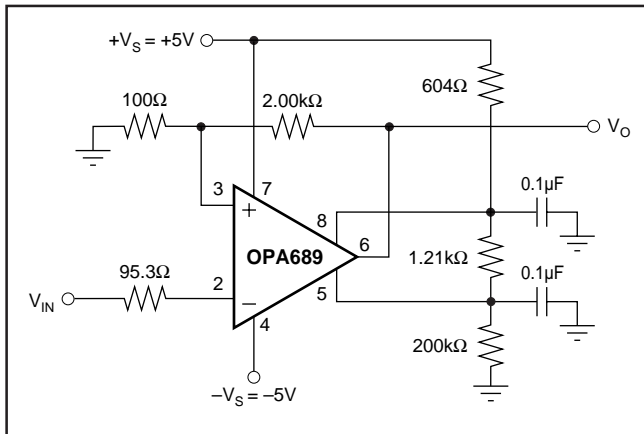

FIGURE 5. Very High Speed Comparator.

### TRANSIMPEDANCE AMPLIFIER

Figure 6 shows a transimpedance amplifier that has exceptional overdrive characteristics. The feedback capacitor ( $C_F$ ) stabilizes the circuit for the assumed diode capacitance ( $C_D$ ).

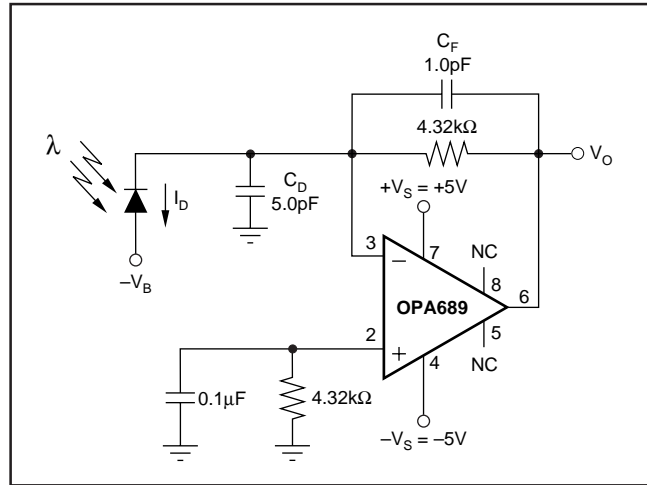

FIGURE 6. Transimpedance Amplifier.

## DESIGN-IN TOOLS

### APPLICATIONS SUPPORT

The Burr-Brown Applications Department is available for design assistance at phone number 1-800-548-6132 (US/Canada only). The Burr-Brown Internet web page (<http://www.burr-brown.com>) has the latest data sheets and other design aids.

### DEMONSTRATION BOARDS

Two PC boards are available to assist in the initial evaluation of circuit performance of the OPA689 in both package styles. These will be available as an unpopulated PCB with descriptive documentation. See the board literature for more information. The summary information for these boards is shown below:

PRODUCT	PACKAGE	BOARD PART NUMBER	LITERATURE REQUEST NUMBER
OPA689P	8-Pin DIP	DEM-OPA68xP	MKT-350
OPA689U	8-Pin SO-8	DEM-OPA68xU	MKT-351

Contact the Burr-Brown Applications Department for availability of these boards.

### SPICE MODELS

Computer simulation of circuit performance using SPICE is often useful when analyzing analog circuit or system performance. This is particularly true for high speed amplifier circuits where parasitic capacitance and inductance can have a major effect on frequency response.

SPICE models are available through the Burr-Brown web site ([www.burr-brown.com](http://www.burr-brown.com)). These models do a good job of predicting small-signal AC and transient performance under a wide variety of operating conditions. They do not do as well in predicting the harmonic distortion, temperature effects, or different gain and phase characteristics. These models do not distinguish between the AC performance of different package types.

# OPERATING INFORMATION

## THEORY OF OPERATION

The OPA689 is a voltage feedback op amp that is stable for gains  $\geq +4$ . The output voltage is limited to a range set by the limiter pins (5 and 8). When the input tries to overdrive the output, the limiters take control of the output buffer. This avoids saturating any parts in the signal path, gives quick overdrive recovery, and gives consistent limiter accuracy for any gain.

This part is de-compensated (stable for gains  $\geq +4$ ). This gives greater bandwidth, higher slew rate, and lower noise than the unity gain stable companion part OPA688.

The limiters have a very sharp transition from the linear region of operation to output limiting. This allows the limiter voltages to be set very near ( $<100$  mV) the desired signal range. The distortion performance is also very good near the limiter voltages.

## CIRCUIT LAYOUT

Achieving optimum performance with the high frequency OPA689 requires careful attention to layout design and component selection. Recommended PCB layout techniques and component selection criteria are:

a) **Minimize parasitic capacitance to any ac ground** for all of the signal I/O pins. Open a window in the ground and power planes around the signal I/O pins, and leave the ground and power planes unbroken elsewhere.

b) **Provide a high quality power supply.** Use linear regulators, ground plane, and power planes, to provide power. Place high frequency  $0.1\mu\text{F}$  decoupling capacitors  $< 0.2$ " away from each power supply pin. Use wide, short traces to connect to these capacitors to the ground and power planes. Also use larger ( $2.2\mu\text{F}$  to  $6.8\mu\text{F}$ ) high frequency decoupling capacitors to bypass lower frequencies. They may be somewhat further from the device, and be shared among several adjacent devices.

c) **Place external components close** to the OPA689. This minimizes inductance, ground loops, transmission line effects and propagation delay problems. Be extra careful with the feedback ( $R_F$ ), input and output resistors.

d) **Use high frequency components** to minimize parasitic elements. Resistors should be a very low reactance type. Surface mount resistors work best and allow a tighter layout. Metal film or carbon composition axially-leaded resistors can also provide good performance when their leads are as short as possible. Never use wire-wound resistors for high frequency applications. Remember that most potentiometers have large parasitic capacitances and inductances.

Multilayer ceramic chip capacitors work best and take up little space. Monolithic ceramic capacitors also work very well. Use RF type capacitors with low ESR and ESL. The large power pin bypass capacitors ( $2.2\mu\text{F}$  to  $6.8\mu\text{F}$ ) should be tantalum for better high frequency and pulse performance.

e) **Choose low resistor values** to minimize the time constant set by the resistor and its parasitic parallel capacitance. Good metal film or surface mount resistors have approximately  $0.2\text{pF}$  parasitic parallel capacitance. For resistors  $> 1.5\text{k}\Omega$ , this adds a pole and/or zero below  $500\text{MHz}$ .

Make sure that the output loading is not too heavy. The recommended  $750\Omega$  feedback resistor is a good starting point in your design.

f) **Use short direct traces to other wideband devices** on the board. Short traces act as a lumped capacitive load. Wide traces (50 to 100 mils) should be used. Estimate the total capacitive load at the output, and use the series isolation resistor recommended in the  $R_S$  vs *Capacitive Load* plot. Parasitic loads  $< 2\text{pF}$  may not need the isolation resistor.

g) **When long traces are necessary**, use transmission line design techniques (consult an ECL design handbook for microstrip and stripline layout techniques). A  $50\Omega$  transmission line is not required on board—a higher characteristic impedance will help reduce output loading. Use a matching series resistor at the output of the op amp to drive a transmission line, and a matched load resistor at the other end to make the line appear as a resistor. If the 6dB of attenuation that the matched load produces is not acceptable, and the line is not too long, use the series resistor at the source only. This will isolate the op amp output from the reactive load presented by the line, but the frequency response will be degraded.

Multiple destination devices are best handled as separate transmission lines, each with its own series source and shunt load terminations. Any parasitic impedances acting on the terminating resistors will alter the transmission line match, and can cause unwanted signal reflections and reactive loading.

h) **Do not use sockets** for high speed parts like the OPA689. The additional lead length and pin-to-pin capacitance introduced by the socket creates an extremely troublesome parasitic network. Best results are obtained by soldering the part onto the board. If socketing for DIP prototypes is desired, high frequency flush mount pins (e.g., McKenzie Technology #710C) can give good results.

## POWER SUPPLIES

The OPA689 is nominally specified for operation using either  $\pm 5\text{V}$  supplies or a single  $+5\text{V}$  supply. The maximum specified total supply voltage of  $13\text{V}$  allows reasonable tolerances on the supplies. Higher supply voltages can break down internal junctions, possibly leading to catastrophic failure. Single supply operation is possible as long as common mode voltage constraints are observed. The common mode input and output voltage specifications can be interpreted as a required headroom to the supply voltage. Observing this input and output headroom requirement will allow design of non-standard or single supply operation circuits. Figure 2 shows one approach to single-supply operation.

## ESD PROTECTION

ESD damage is known to damage MOSFET devices, but any semiconductor device is vulnerable to ESD damage. This is particularly true for very high speed, fine geometry processes.

ESD damage can cause subtle changes in amplifier input characteristics without necessarily destroying the device. In precision operational amplifiers, this may cause a noticeable degradation of offset voltage and drift. Therefore, ESD handling precautions are required when handling the OPA689.

## OUTPUT LIMITERS

The output voltage is linearly dependent on the input(s) when it is between the limiter voltages  $V_H$  (pin 8) and  $V_L$  (pin 5). When the output tries to exceed  $V_H$  or  $V_L$ , the corresponding limiter buffer takes control of the output voltage and holds it at  $V_H$  or  $V_L$ .

Because the limiters act on the output, their accuracy does not change with gain. The transition from the linear region of operation to output limiting is sharp—the desired output signal can safely come to within 30mV of  $V_H$  or  $V_L$ . Distortion performance is also good over the same range.

The limiter voltages can be set to within 0.7V of the supplies ( $V_L \geq -V_S + 0.7V$ ,  $V_H \leq +V_S - 0.7V$ ). They must also be at least 200mV apart ( $V_H - V_L \geq 0.2V$ ).

When pins 5 and 8 are left open,  $V_H$  and  $V_L$  go to the Default Voltage Limit; the minimum values are in the spec table. Looking at Figure 7 for the zero bias current case will show the expected range of ( $V_S$  – default limit voltages) = headroom).

When the limiter voltages are more than 2.1V from the supplies ( $V_L \geq -V_S + 2.1V$  or  $V_H \leq +V_S - 2.1V$ ), you can use simple resistor dividers to set  $V_H$  and  $V_L$  (see Figure 1). Make sure you include the Limiter Input Bias Currents (Figure 7) in the calculations (i.e.,  $I_{VL} \approx -50\mu A$  out of pin 5, and  $I_{VH} \approx +50\mu A$  out of pin 8). For good limiter voltage accuracy, run at least 1mA quiescent bias current through these resistors.

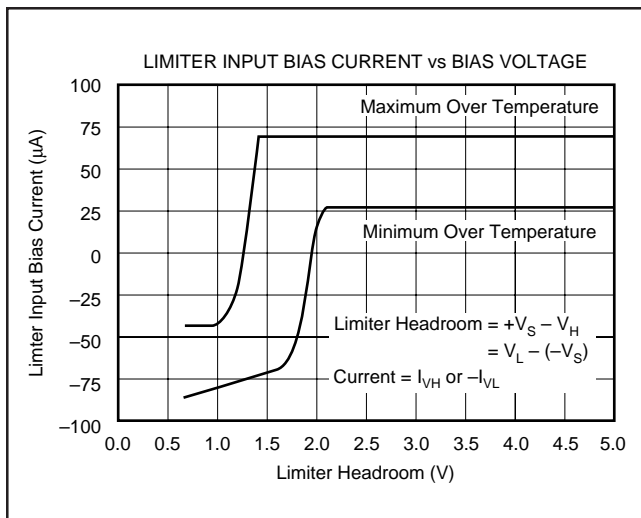

FIGURE 7. Limiter Bias Current vs Limiter Voltage.

When the limiter voltages need to be within 2.1V of the supplies ( $V_L \leq -V_S + 2.1V$  or  $V_H \geq +V_S - 2.1V$ ), use low impedance voltage sources to set  $V_H$  and  $V_L$  to minimize errors due to bias current uncertainty. This will typically be the case for single supply operation ( $V_S = +5V$ ). Figure 2 runs 2.5mA through the resistive divider that sets  $V_H$  and  $V_L$ . This keeps errors due to  $I_{VH}$  and  $I_{VL} < \pm 1\%$  of the target limit voltages.

The limiters' DC accuracy depends on attention to detail. The two dominant error sources can be improved as follows:

- Power supplies, when used to drive resistive dividers that set  $V_H$  and  $V_L$ , can contribute large errors (e.g., (5%). Using a more accurate source, or bypassing pins 5 and 8 with good capacitors, will improve limiter PSRR.
- The resistor tolerances in the resistive divider can also dominate. Use 1% resistors.

Other error sources also contribute, but should have little impact on the limiters' DC accuracy:

- Reduce offsets caused by the Limiter Input Bias Currents. Select the resistors in the resistive divider(s) as described above.
- Consider the signal path DC errors as contributing to the uncertainty in the useable output range.
- The Limiter Offset Voltage only slightly degrades the limiter accuracy.

Figure 8 shows how the limiters affect distortion performance. Virtually no degradation in linearity is observed for output voltages swinging right up to the limiter voltages.

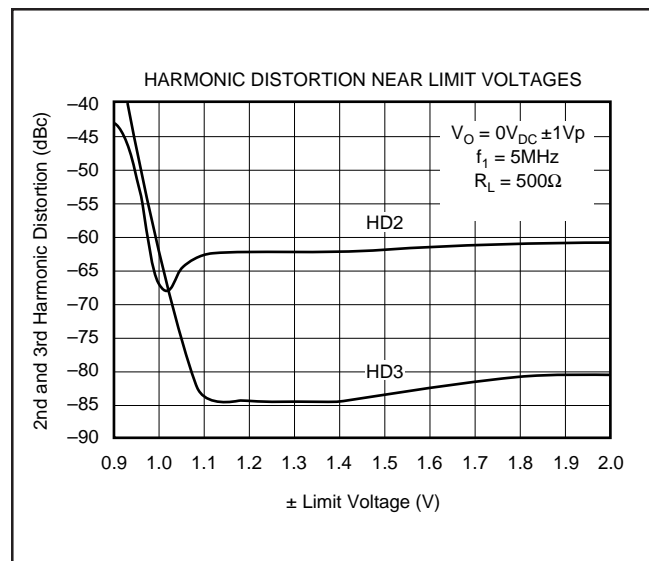

FIGURE 8. Linearity Guardband.

## OFFSET VOLTAGE ADJUSTMENT

The circuit in Figure 9 allows offset adjustment without degrading offset drift with temperature. Use this circuit with caution since power supply noise can inadvertently couple into the op amp.

Remember that additional offset errors can be created by the amplifier's input bias currents. Whenever possible, match the resistance seen by both DC Input Bias Currents by using  $R_3$ . This minimizes the output offset voltage caused by the Input Bias Currents.

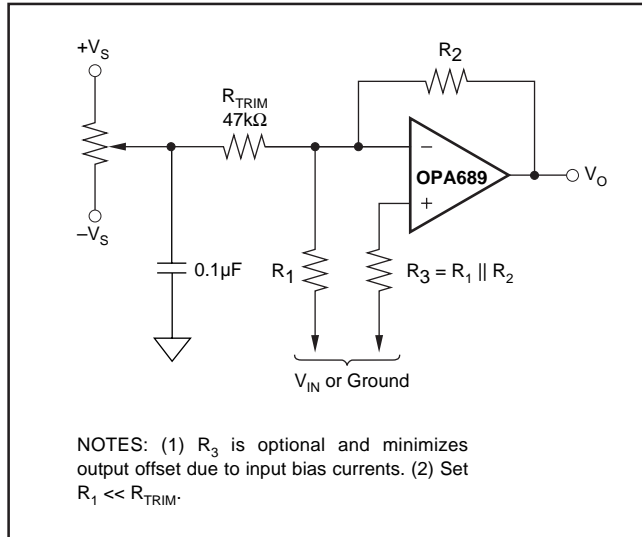

FIGURE 9. Offset Voltage Trim.

## OUTPUT DRIVE

The OPA689 has been optimized to drive 500Ω loads, such as A/D converters. It still performs very well driving 100Ω loads. This makes the OPA689 an ideal choice for a wide range of high frequency applications.

Many high speed applications, such as driving A/D converters, require op amps with low output impedance. As shown in the *Output Impedance vs Frequency* performance curve, the OPA689 maintains very low closed-loop output impedance over frequency. Closed-loop output impedance increases with frequency since loop gain decreases with frequency.

## THERMAL CONSIDERATIONS

The OPA689 will not require heat-sinking under most operating conditions. Maximum desired junction temperature will set a maximum allowed internal power dissipation as described below. In no case should the maximum junction temperature be allowed to exceed 175°C.

The total internal power dissipation ( $P_D$ ) is the sum of quiescent power ( $P_{DQ}$ ) and the additional power dissipated in the output stage ( $P_{DL}$ ) while delivering load power.  $P_{DQ}$  is simply the specified no-load supply current times the total supply voltage across the part.  $P_{DL}$  depends on the required output signals and loads. For a grounded resistive load, and equal bipolar supplies, it is at a maximum when the output is at 1/2 either supply voltage. In this condition,  $P_{DL} = V_S^2/(4R_L)$  where  $R_L$  includes the feedback network loading. Note that it is the power in the output stage, and not in the load, that determines internal power dissipation.

The operating junction temperature is:  $T_J = T_A + P_D \theta_{JA}$ , where  $T_A$  is the ambient temperature.

For example, the maximum  $T_J$  for a OPA689U with  $G = +6$ ,  $R_{FB} = 750\Omega$ ,  $R_L = 100\Omega$ , and  $\pm V_S = \pm 5V$  at the maximum  $T_A = +85^\circ C$  is calculated this way:

$$P_{DQ} = (10V \cdot 20mA) = 200mW$$

$$P_{DL} = \frac{(5V)^2}{4 \cdot (100\Omega \parallel 850\Omega)}$$

$$P_D = 200mW + 70mW = 270mW$$

$$T_J = 85^\circ C + 270mW \cdot 125^\circ C/W = 119^\circ C$$

## CAPACITIVE LOADS

Capacitive loads, such as flash A/D converters, will decrease the amplifier's phase margin, which may cause peaking or oscillations. Capacitive loads  $\geq 1pF$  should be isolated by connecting a small resistor in series with the output as shown in Figure 10. Increasing the gain from +6 will improve the capacitive drive capabilities due to increased phase margin.

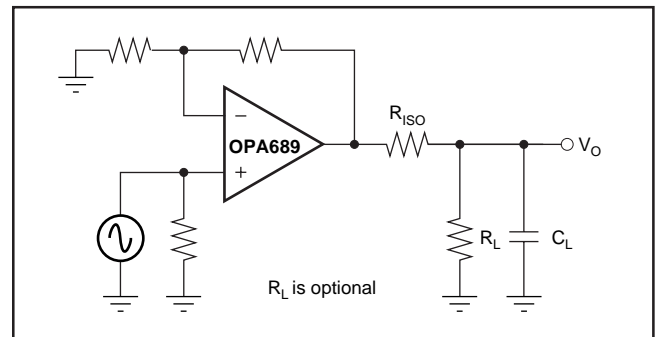

FIGURE 10. Driving Capacitive Loads.

In general, capacitive loads should be minimized for optimum high frequency performance. The capacitance of coax cable (29pF/foot for RG-58) will not load the amplifier when the coaxial cable, or transmission line, is terminated in its characteristic impedance.

## FREQUENCY RESPONSE COMPENSATION

The OPA689 is internally compensated to be stable at a gain of +4, and has a nominal phase margin of  $60^\circ$  at a gain of +6. Phase margin and peaking improve at higher gains. Recall that an inverting gain of  $-5$  is equivalent to a gain of +6 for bandwidth purposes (i.e., noise gain = 6).

Standard external compensation techniques work with this device. For example, in the inverting configuration, the bandwidth may be limited without modifying the inverting gain by placing a series RC network to ground on the inverting node. This has the effect of increasing the noise gain at high frequencies, which limits the bandwidth.

To maintain a large bandwidth at high gains, cascade several op amps.

In applications where a large feedback resistor is required, such as photodiode transimpedance amplifier, the parasitic capacitance from the inverting input to ground causes peaking or oscillations. To compensate for this effect, connect a small capacitor in parallel with the feedback resistor. The bandwidth will be limited by the pole that the feedback resistor and this capacitor create. In other high gain applications, use a three resistor “Tee” network to reduce the RC time constants set by the parasitic capacitances. Be careful to not increase the noise generated by this feedback network too much.

## PULSE SETTling TIME

The OPA689 is capable of an extremely fast settling time in response to a pulse input. Frequency response flatness and phase linearity are needed to obtain the best settling times. For capacitive loads, such as an A/D converter, use the

recommended  $R_S$  in the  $R_S$  vs *Capacitive Load* plot. Extremely fine scale settling (0.01%) requires close attention to ground return current in the supply decoupling capacitors.

The pulse settling characteristics when recovering from overdrive are very good.

## DISTORTION

The OPA689’s distortion performance is specified for a  $500\Omega$  load, such as an A/D converter. Driving loads with smaller resistance will increase the distortion as illustrated in Figure 11. Remember to include the feedback network in the load resistance calculations.

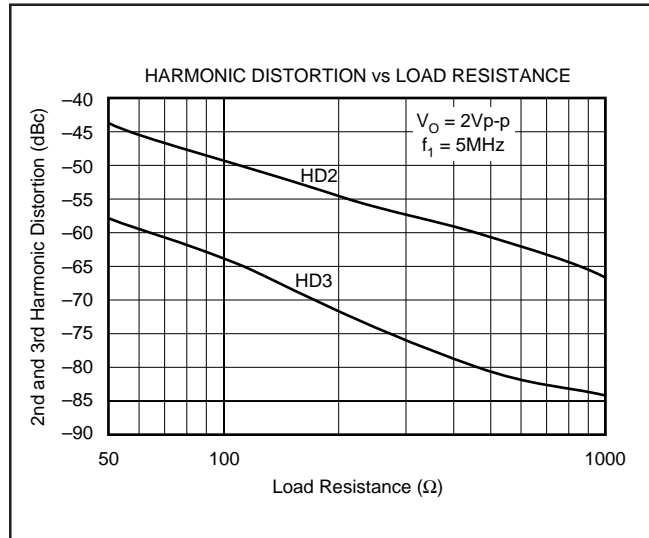

FIGURE 11. 5MHz Harmonic Distortion vs Load Resistance.

---

## PACKAGING INFORMATION

ORDERABLE DEVICE	STATUS(1)	PACKAGE TYPE	PACKAGE DRAWING	PINS	PACKAGE QTY
OPA689P	LIFEBUY	PDIP	P	8	50
OPA689U	OBSOLETE	SOIC	D	8	
OPA689U/2K5	OBSOLETE	SOIC	D	8	

(1) The marketing status values are defined as follows:

**ACTIVE:** Product device recommended for new designs.

**LIFEBUY:** TI has announced that the device will be discontinued, and a lifetime-buy period is in effect.

**NRND:** Not recommended for new designs. Device is in production to support existing customers, but TI does not recommend using this part in a new design.

**PREVIEW:** Device has been announced but is not in production. Samples may or may not be available.

**OBSOLETE:** TI has discontinued the production of the device.

---

## IMPORTANT NOTICE

Texas Instruments Incorporated and its subsidiaries (TI) reserve the right to make corrections, modifications, enhancements, improvements, and other changes to its products and services at any time and to discontinue any product or service without notice. Customers should obtain the latest relevant information before placing orders and should verify that such information is current and complete. All products are sold subject to TI's terms and conditions of sale supplied at the time of order acknowledgment.

TI warrants performance of its hardware products to the specifications applicable at the time of sale in accordance with TI's standard warranty. Testing and other quality control techniques are used to the extent TI deems necessary to support this warranty. Except where mandated by government requirements, testing of all parameters of each product is not necessarily performed.

TI assumes no liability for applications assistance or customer product design. Customers are responsible for their products and applications using TI components. To minimize the risks associated with customer products and applications, customers should provide adequate design and operating safeguards.

TI does not warrant or represent that any license, either express or implied, is granted under any TI patent right, copyright, mask work right, or other TI intellectual property right relating to any combination, machine, or process in which TI products or services are used. Information published by TI regarding third-party products or services does not constitute a license from TI to use such products or services or a warranty or endorsement thereof. Use of such information may require a license from a third party under the patents or other intellectual property of the third party, or a license from TI under the patents or other intellectual property of TI.

Reproduction of information in TI data books or data sheets is permissible only if reproduction is without alteration and is accompanied by all associated warranties, conditions, limitations, and notices. Reproduction of this information with alteration is an unfair and deceptive business practice. TI is not responsible or liable for such altered documentation.

Resale of TI products or services with statements different from or beyond the parameters stated by TI for that product or service voids all express and any implied warranties for the associated TI product or service and is an unfair and deceptive business practice. TI is not responsible or liable for any such statements.

Following are URLs where you can obtain information on other Texas Instruments products and application solutions:

<b>Products</b>		<b>Applications</b>	
Amplifiers	<a href="http://amplifier.ti.com">amplifier.ti.com</a>	Audio	<a href="http://www.ti.com/audio">www.ti.com/audio</a>
Data Converters	<a href="http://dataconverter.ti.com">dataconverter.ti.com</a>	Automotive	<a href="http://www.ti.com/automotive">www.ti.com/automotive</a>
DSP	<a href="http://dsp.ti.com">dsp.ti.com</a>	Broadband	<a href="http://www.ti.com/broadband">www.ti.com/broadband</a>
Interface	<a href="http://interface.ti.com">interface.ti.com</a>	Digital Control	<a href="http://www.ti.com/digitalcontrol">www.ti.com/digitalcontrol</a>
Logic	<a href="http://logic.ti.com">logic.ti.com</a>	Military	<a href="http://www.ti.com/military">www.ti.com/military</a>
Power Mgmt	<a href="http://power.ti.com">power.ti.com</a>	Optical Networking	<a href="http://www.ti.com/opticalnetwork">www.ti.com/opticalnetwork</a>
Microcontrollers	<a href="http://microcontroller.ti.com">microcontroller.ti.com</a>	Security	<a href="http://www.ti.com/security">www.ti.com/security</a>
		Telephony	<a href="http://www.ti.com/telephony">www.ti.com/telephony</a>
		Video & Imaging	<a href="http://www.ti.com/video">www.ti.com/video</a>
		Wireless	<a href="http://www.ti.com/wireless">www.ti.com/wireless</a>

Mailing Address: Texas Instruments  
Post Office Box 655303 Dallas, Texas 75265

Copyright © 2004, Texas Instruments Incorporated