

OPA603

High Speed, Current-Feedback, High Voltage OPERATIONAL AMPLIFIER

FEATURES

- WIDE SUPPLY RANGE: ± 4.5 to ± 18 V
- BANDWIDTH: 100MHz, $G = 1$ to 10
- SLEW RATE: 1000V/ μ s
- FAST SETTLING TIME: 50ns to 0.1%
- HIGH OUTPUT CURRENT: ± 150 mA peak
- HIGH OUTPUT VOLTAGE: ± 12 V

APPLICATIONS

- VIDEO AMPLIFIER
- PULSE AMPLIFIER
- SONAR, ULTRASOUND BUFFERS
- ATE PIN DRIVERS
- xDSL LINE DRIVER
- FAST DATA ACQUISITION
- WAVEFORM GENERATORS

DESCRIPTION

The OPA603 is a high-speed current-feedback op amp with guaranteed specifications at both ± 5 V and ± 15 V power supplies. It can deliver full ± 10 V signals into 150 Ω loads with up to 1000V/ μ s slew rate. This allows it to drive terminated 75 Ω cables. With 150mA peak output current capability it is suitable for driving load capacitance or long lines at high speed.

In contrast with conventional op amps, the current-feedback approach provides nearly constant bandwidth and settling time over a wide range of closed-loop voltage gains.

The OPA603 is available in a plastic 8-pin DIP and SO-16 surface-mount packages, specified over the industrial temperature range.

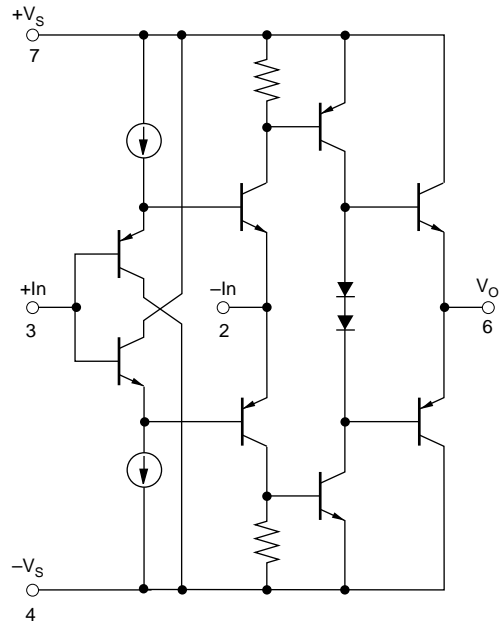

SPECIFICATIONS: $V_S = \pm 15V$

ELECTRICAL

At $T_A = +25^\circ C$, and $R_L = 150\Omega$, unless otherwise noted.

PARAMETER	CONDITIONS	OPA603AP, AU			UNITS
		MIN	TYP	MAX	
INPUT OFFSET VOLTAGE Initial vs Temperature vs Common-Mode Voltage vs Supply (tracking) Voltage vs Supply (non-tracking) ⁽¹⁾	$V_{CM} = \pm 10V$ $V_S = \pm 12V$ to $\pm 18V$ $ V_S = 12V$ to $18V$			5	mV $\mu V/^\circ C$ dB dB dB
+INPUT BIAS CURRENT Initial vs Temperature vs Common-Mode vs Supply (tracking) vs Supply (non-tracking) ⁽¹⁾	$V_{CM} = \pm 10V$ $V_S = \pm 12V$ to $\pm 18V$ $ V_S = 12V$ to $18V$			5	μA $nA/^\circ C$ nA/V nA/V nA/V
-INPUT BIAS CURRENT Initial vs Temperature vs Common-Mode vs Supply (tracking) vs Supply (non-tracking) ⁽¹⁾	$V_{CM} = \pm 10V$ $V_S = \pm 12V$ to $\pm 18V$ $ V_S = 12V$ to $18V$			25	μA $nA/^\circ C$ nA/V nA/V nA/V
INPUT IMPEDANCE +Input -Input					$M\Omega \parallel pF$ $\Omega \parallel pF$
OPEN LOOP CHARACTERISTICS Transresistance Transcapacitance	$V_O = \pm 10V$	300	440		k Ω pF
OUTPUT CHARACTERISTICS Voltage Peak Current Short-Circuit Current ⁽²⁾ Output Resistance, Open-Loop	$R_L = 150\Omega$ $V_O = 0V$	± 10	± 12 150 250 70		V mA mA Ω
FREQUENCY RESPONSE Small-Signal Bandwidth ⁽³⁾ Gain Flatness, $\pm 0.5dB$ Full-Power Bandwidth Differential Gain Differential Phase	$G = +2$ $V_O = 20Vp-p$ $f = 4.43MHz$, $V_O = 1V$ $f = 4.43MHz$, $V_O = 1V$	70 35	160 75 10 0.03 0.025		MHz MHz MHz % Degrees
TIME DOMAIN RESPONSE Propagation Delay Rise and Fall Time Settling Time to 0.10% Slew Rate	$G = +2$ 10V Step		10 10 50 1000		ns ns ns V/ μs
DISTORTION 2nd Harmonic Distortion 3rd Harmonic Distortion	$G = +2$, $R_L = 100\Omega$, $f = 10MHz$ $V_O = 0.2Vp-p$ $V_O = 0.2Vp-p$	-60 -70	-65 -90		dBc dBc
POWER SUPPLY Specified Operating Voltage Operating Voltage Range Current		± 4.5	± 15 ± 21	± 18 ± 25	V V mA
TEMPERATURE RANGE Specification Storage		-25 -40		+85 +150	$^\circ C$ $^\circ C$
THERMAL RESISTANCE, θ_{JA}	Soldered to Printed Circuit		90		$^\circ C/W$

NOTES: (1) One power supply fixed at 15V; the other supply varied from 12V to 18V. (2) Observe power derating curve. (3) See bandwidth versus gain curve, Figure 5.

The information provided herein is believed to be reliable; however, BURR-BROWN assumes no responsibility for inaccuracies or omissions. BURR-BROWN assumes no responsibility for the use of this information, and all use of such information shall be entirely at the user's own risk. Prices and specifications are subject to change without notice. No patent rights or licenses to any of the circuits described herein are implied or granted to any third party. BURR-BROWN does not authorize or warrant any BURR-BROWN product for use in life support devices and/or systems.

SPECIFICATIONS: $V_S = \pm 5V$

ELECTRICAL

At $T_A = +25^\circ C$, and $R_L = 75\Omega$, unless otherwise noted.

PARAMETER	CONDITIONS	OPA603AP, AU			UNITS
		MIN	TYP	MAX	
INPUT OFFSET VOLTAGE Initial vs Temperature vs Common-Mode vs Supply (tracking) vs Supply (non-tracking) ⁽¹⁾	$V_{CM} = \pm 3V$ $V_S = \pm 4V$ to $\pm 6V$ $ V_S = 4V$ to $6V$			6	mV
		50	8		$\mu V/^\circ C$
		75	55		dB
			80		dB
			60		dB
+INPUT BIAS CURRENT Initial vs Temperature vs Common-Mode vs Supply (tracking) vs Supply (non-tracking) ⁽¹⁾	$V_{CM} = \pm 3V$ $V_S = \pm 4V$ to $\pm 6V$ $ V_S = 4V$ to $6V$			5	μA
			30		$nA/^\circ C$
			350	600	nA/V
			100	200	nA/V
			200	300	nA/V
-INPUT BIAS CURRENT Initial vs Temperature vs Common-Mode vs Supply (tracking) vs Supply (non-tracking) ⁽¹⁾	$V_{CM} = \pm 3V$ $V_S = \pm 4V$ to $\pm 6V$ $ V_S = 4V$ to $6V$			25	μA
			300		$nA/^\circ C$
			300	600	nA/V
			500	700	nA/V
			2500	3000	nA/V
INPUT IMPEDANCE +Input -Input			3.3 2		M Ω pF
			30 2		Ω pF
OPEN LOOP CHARACTERISTICS Transresistance Transcapacitance	$V_O = \pm 2V$	225	330		k Ω
			2.4		pF
OUTPUT CHARACTERISTICS Voltage Peak Current Short-Circuit Current ⁽²⁾ Output Resistance, Open-Loop	$R_L = 75\Omega$ $V_O = 0V$	± 2	± 2.75		V
			150		mA
			250		mA
			80		Ω
FREQUENCY RESPONSE Small-Signal Bandwidth ⁽³⁾ Gain Flatness, $\pm 0.5dB$ Full-Power Bandwidth Differential Gain Differential Phase	$G = +2$ $f = 4.43MHz, V_O = 1V, R_L = 150\Omega$ $f = 4.43MHz, V_O = 1V, R_L = 150\Omega$		140		MHz
			65		MHz
			20		MHz
			0.03		%
			0.025		Degrees
TIME DOMAIN RESPONSE Propagation Delay Rise and Fall Time Settling Time to 0.10% Slew Rate	$G = +2, R_L = 100\Omega$		15		ns
			20		ns
			60		ns
			750		V/ μs
DISTORTION 2nd Harmonic Distortion 3rd Harmonic Distortion	$G = +2, R_L = 100\Omega, f = 10MHz$ $V_O = 0.2Vp-p$ $V_O = 0.2Vp-p$		-67		dBc
			-78		dBc
POWER SUPPLY Specified Operating Voltage Operating Voltage Range Current			± 5		V
		± 4.5		± 18	V
			± 21	± 25	mA
TEMPERATURE RANGE Specification Storage		-25		+85	$^\circ C$
		-40		+150	$^\circ C$
THERMAL RESISTANCE, $\theta_{JUNCTION-AMBIENT}$	Soldered to Printed Circuit		90		$^\circ C/W$

NOTES: (1) One power supply fixed at 5V; the other supply varied from 4V to 6V. (2) Observe power derating curve. (3) See bandwidth versus gain curves, Figure 5.

PIN CONFIGURATION

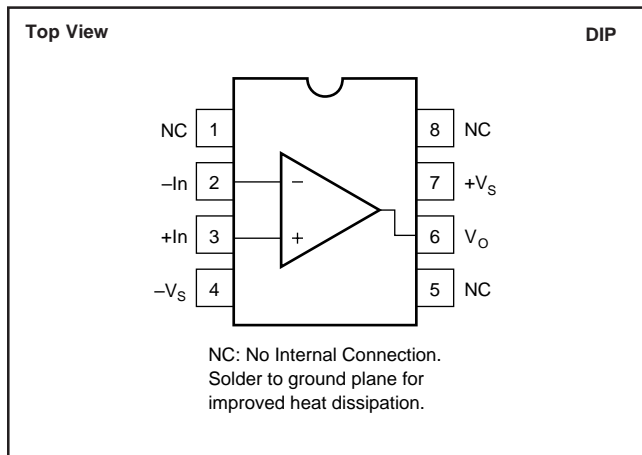

PIN CONFIGURATION

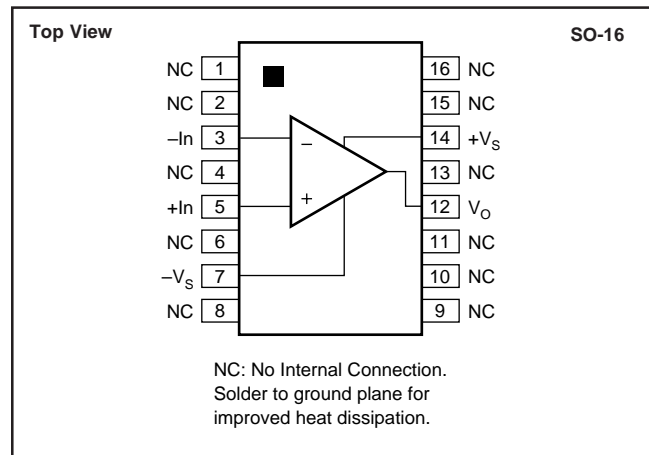

ABSOLUTE MAXIMUM RATINGS

Supply Voltage	±18V
Input Voltage Range	±Vs
Differential Input Voltage	±6V
Power Dissipation	See derating curve
Operating Temperature	+100°C
Storage Temperature	+150°C
Junction Temperature	+150°C
Lead Temperature (soldering, 10s)	+300°C
Lead Temperature (soldering SO-16 package, 3s)	+260°C

PACKAGE/ORDERING INFORMATION

PRODUCT	PACKAGE	PACKAGE DRAWING NUMBER ⁽¹⁾	SPECIFIED TEMPERATURE RANGE
OPA603AP	Plastic DIP	006	-25°C to +85°C
OPA603AU	SO-16	211	-25°C to +85°C

NOTE: (1) For detailed drawing and dimension table, please see end of data sheet, or Appendix C of Burr-Brown IC Data Book.



ELECTROSTATIC DISCHARGE SENSITIVITY

This integrated circuit can be damaged by ESD. Burr-Brown recommends that all integrated circuits be handled with appropriate precautions. Failure to observe proper handling and installation procedures can cause damage.

ESD damage can range from subtle performance degradation to complete device failure. Precision integrated circuits may be more susceptible to damage because very small parametric changes could cause the device not to meet its published specifications.

TYPICAL PERFORMANCE CURVES

At $T_A = +25^\circ\text{C}$, unless otherwise noted.

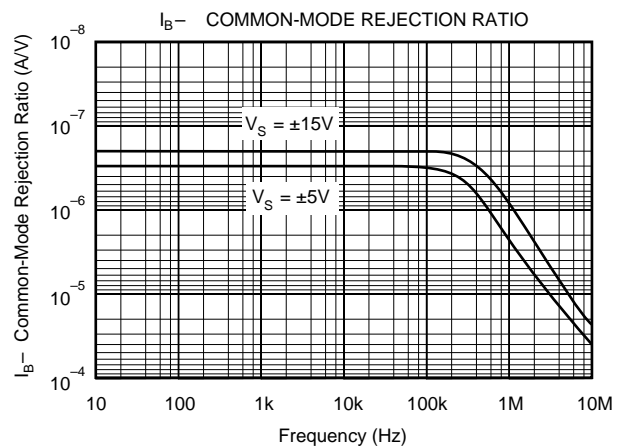
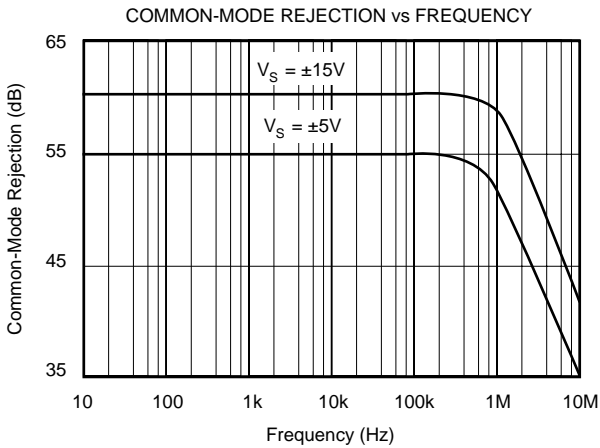
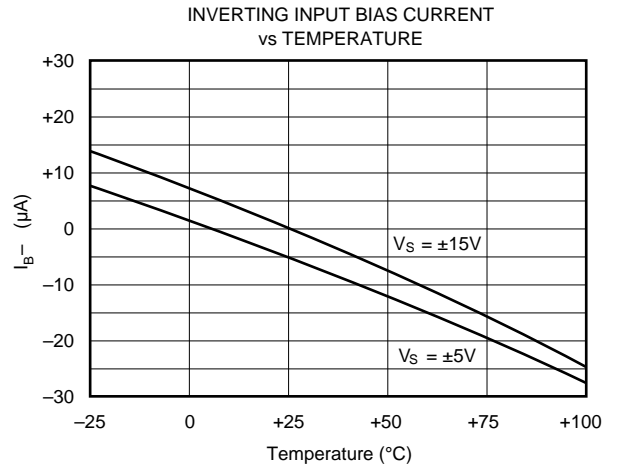
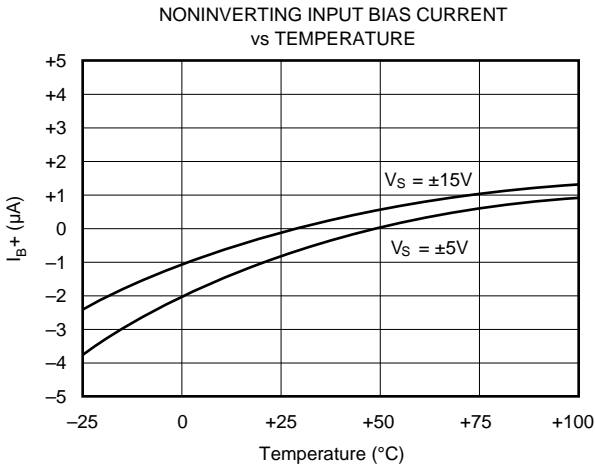
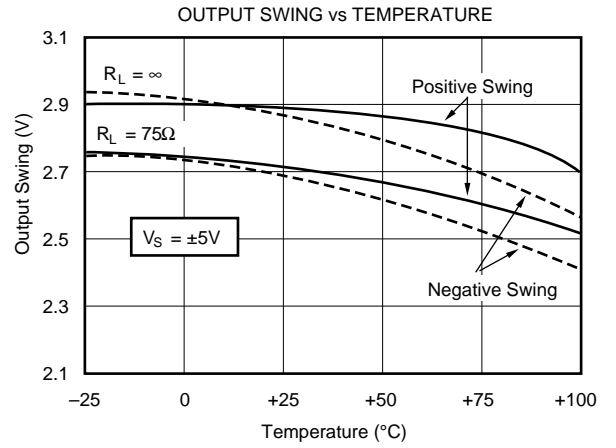
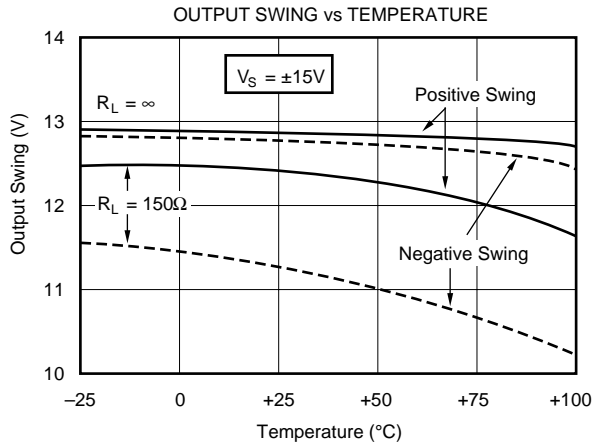

TYPICAL PERFORMANCE CURVES (CONT)

At $T_A = +25^\circ\text{C}$, unless otherwise noted.

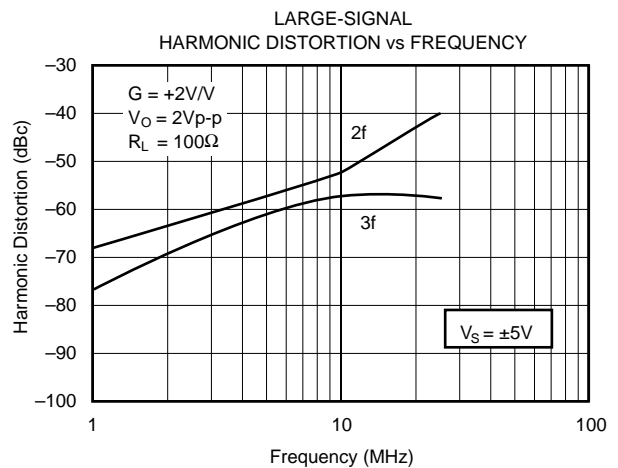
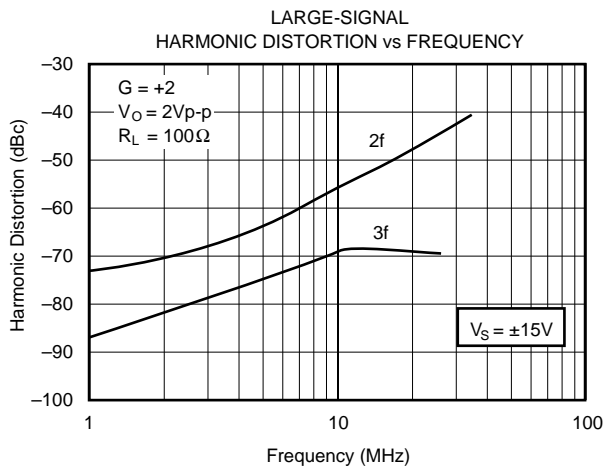
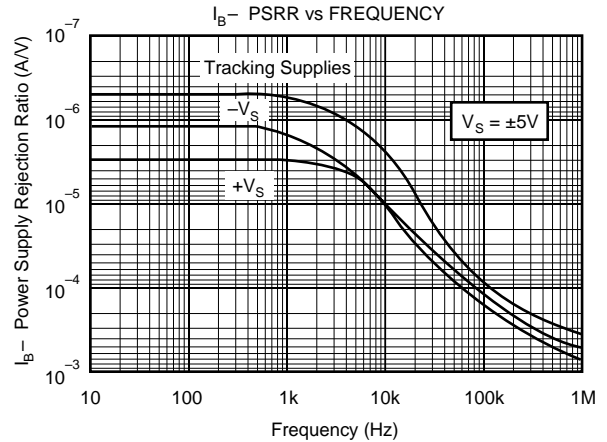
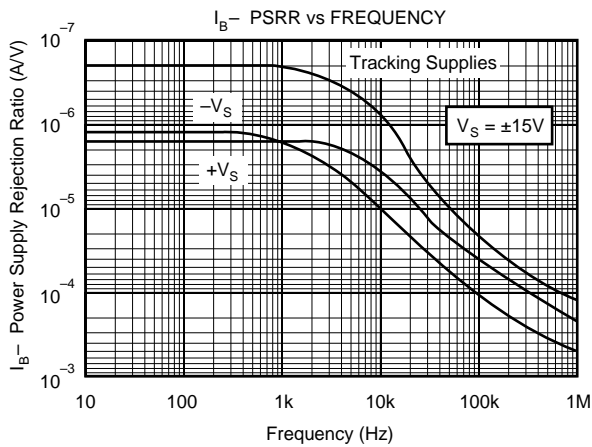
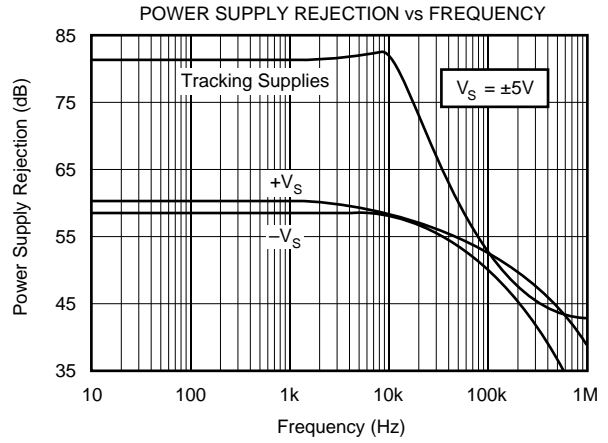
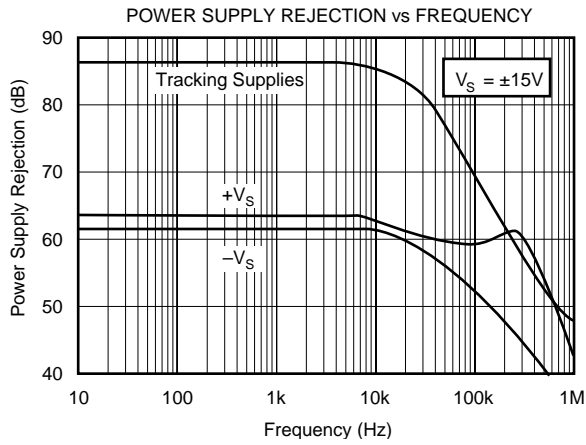

TYPICAL PERFORMANCE CURVES (CONT)

At $T_A = +25^\circ\text{C}$, unless otherwise noted.

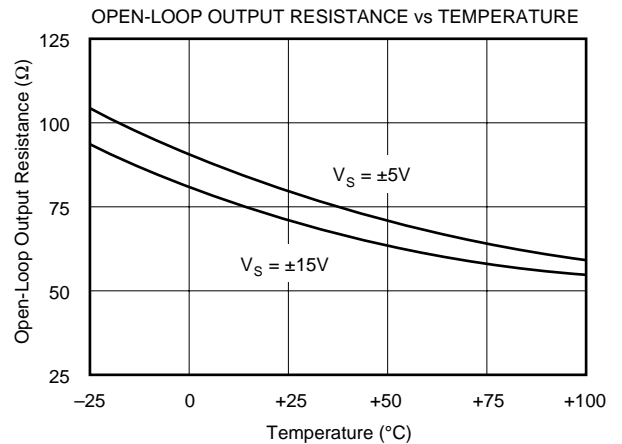
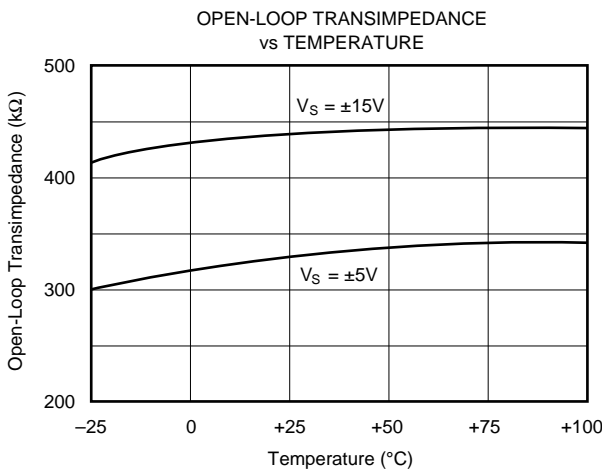
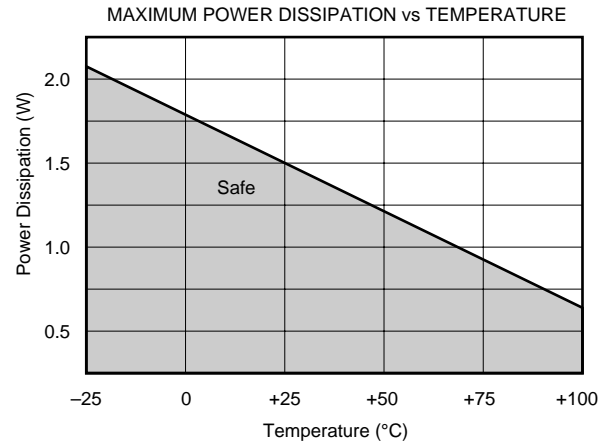
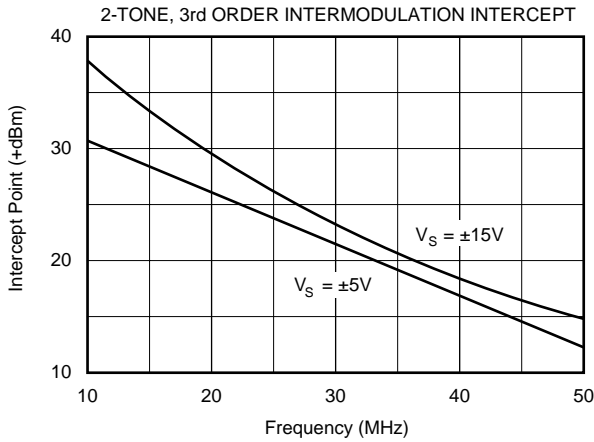
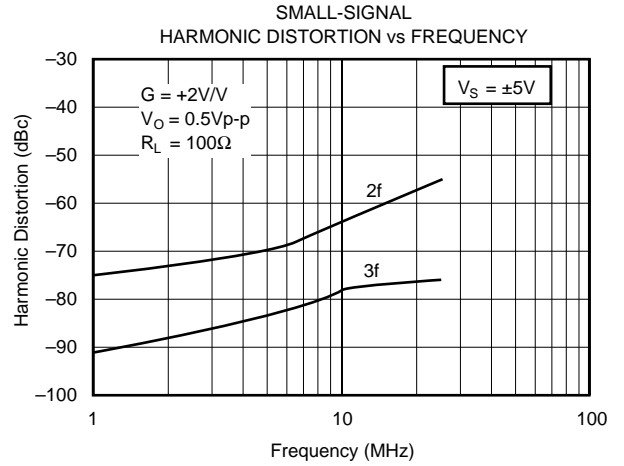
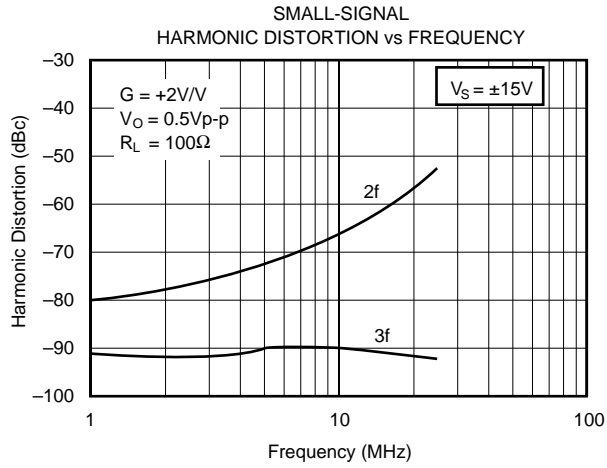

TYPICAL PERFORMANCE CURVES (CONT)

At $T_A = +25^\circ\text{C}$, unless otherwise noted.

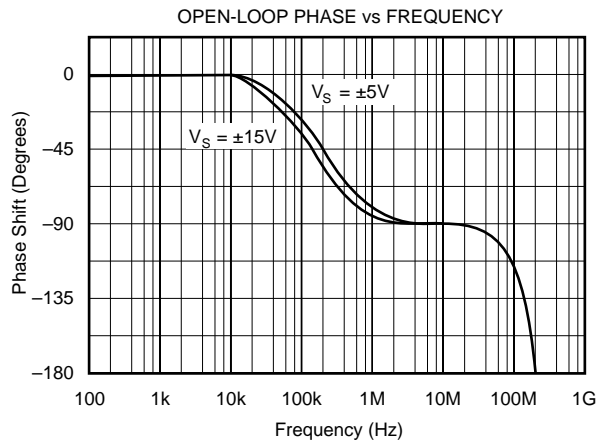
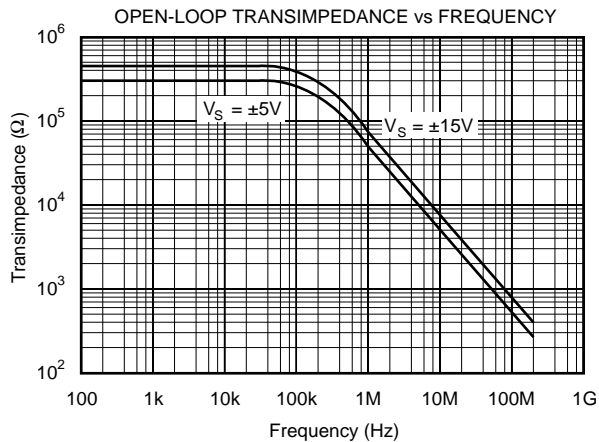
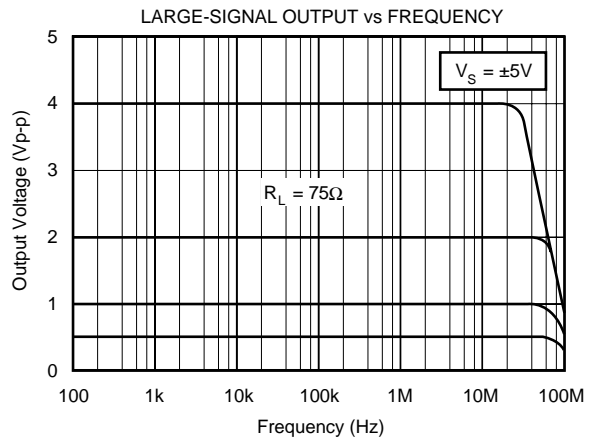
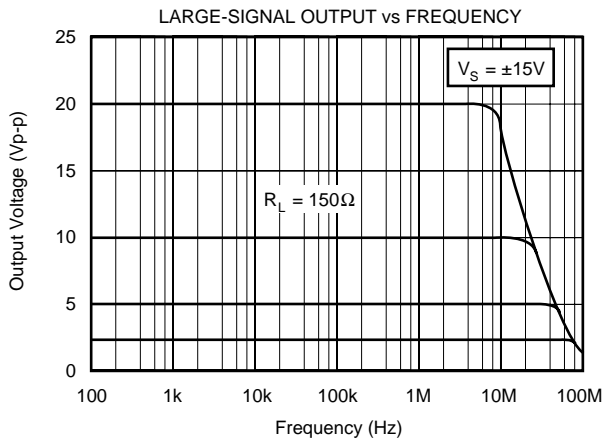
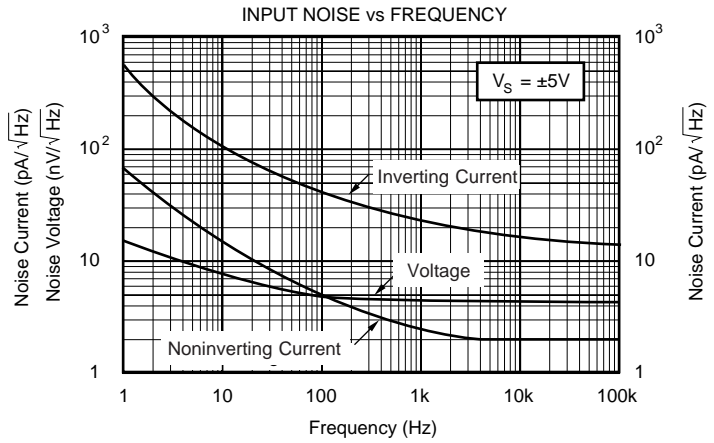
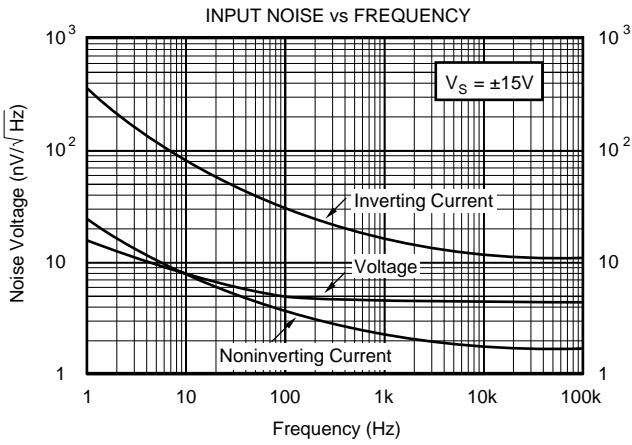

TYPICAL PERFORMANCE CURVES (CONT)

At $T_A = +25^\circ\text{C}$, unless otherwise noted.

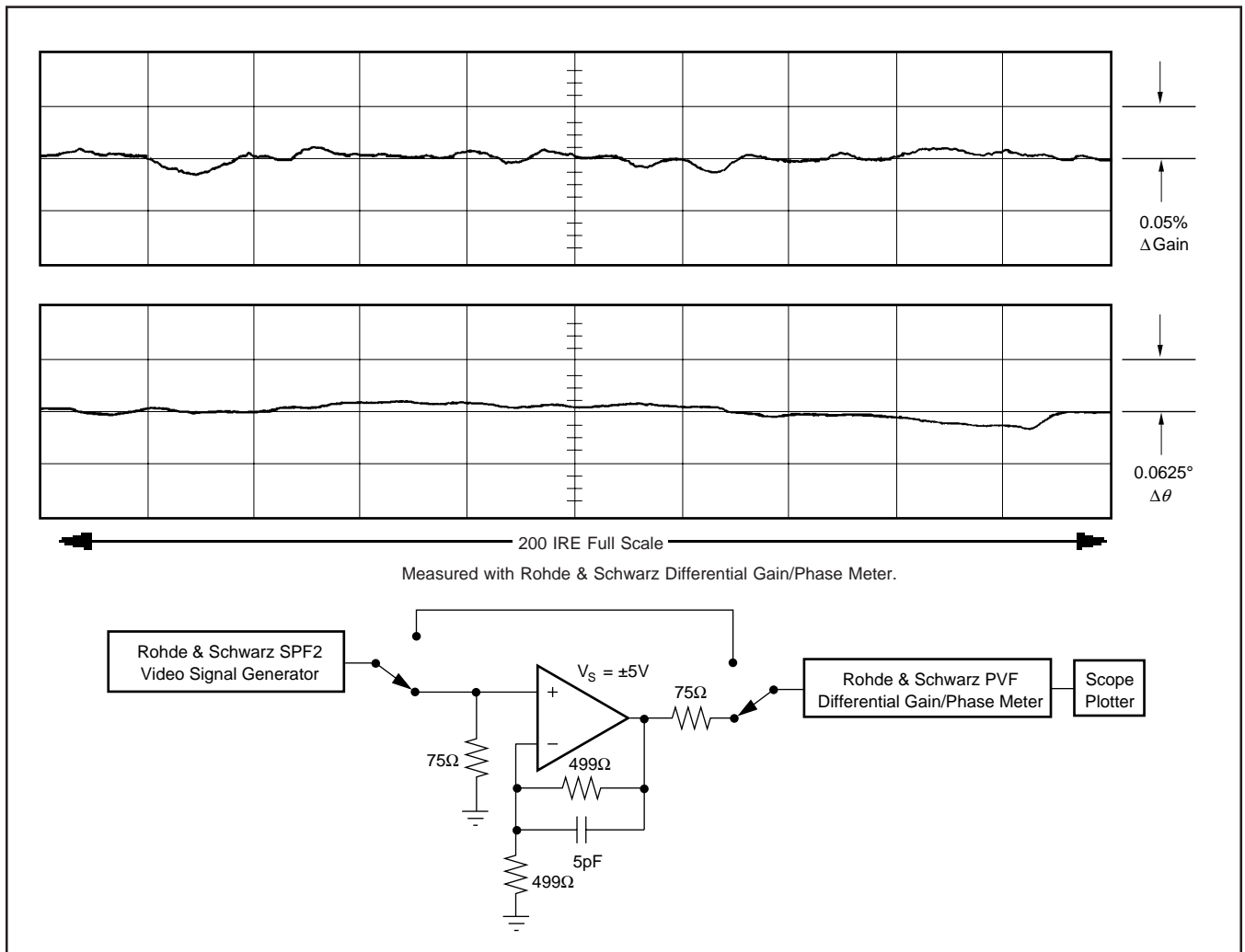
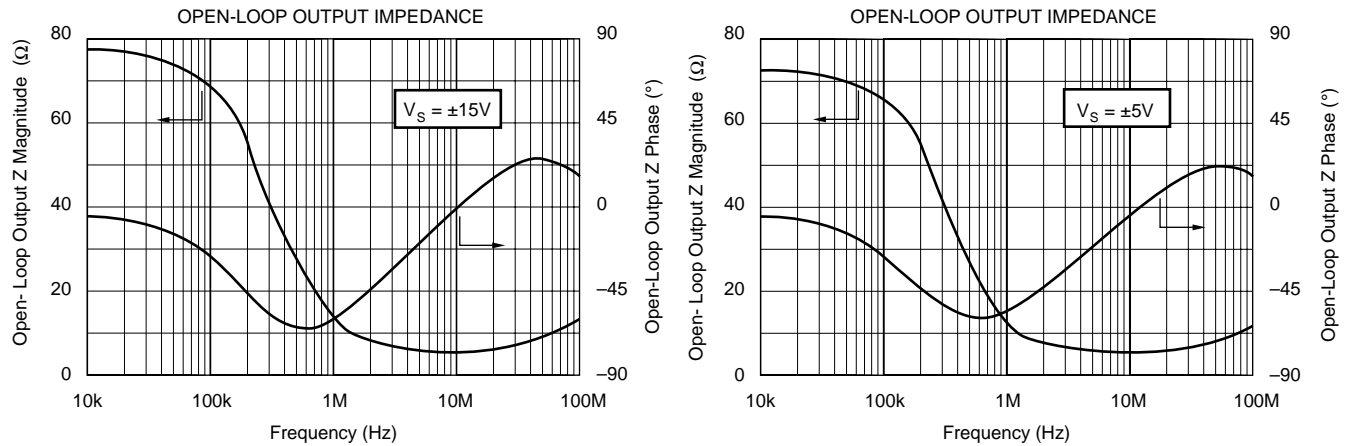

FIGURE 1. Video Differential Gain/Phase Performance.

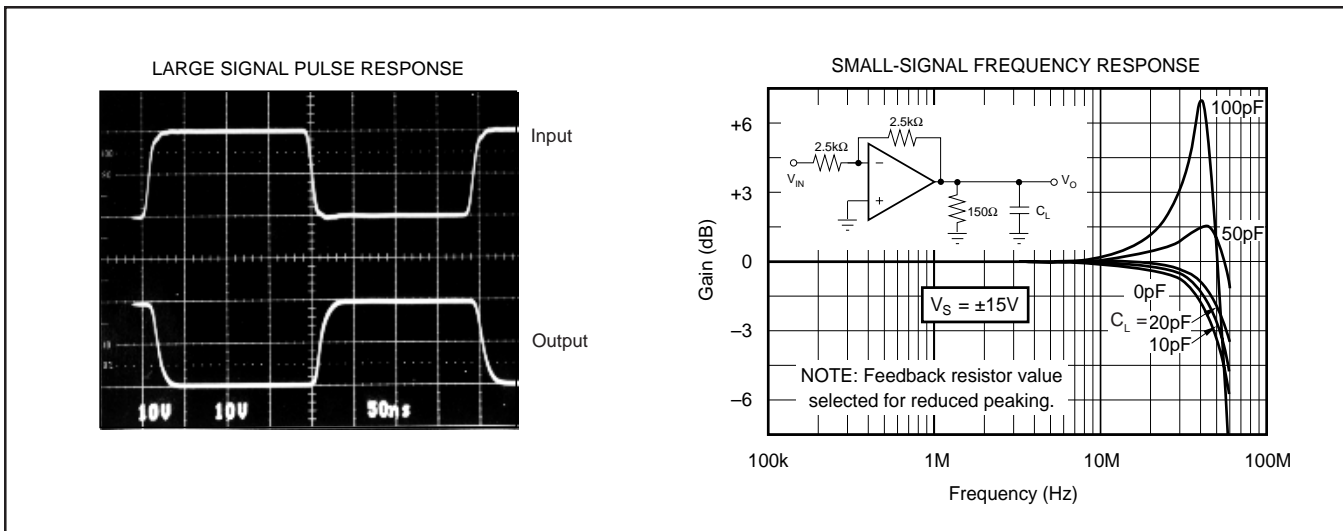

FIGURE 2. Dynamic Response, Inverting Unity-Gain.

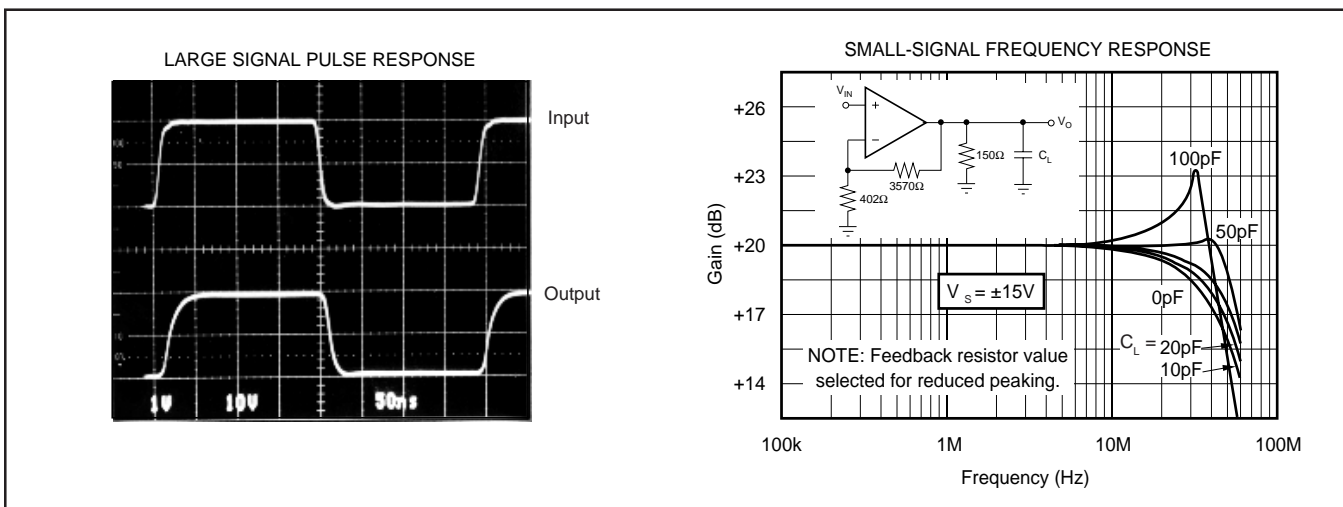

FIGURE 3. Dynamic Response, Gain = +10.

APPLICATIONS INFORMATION

For most circuit configurations, the OPA603 current-feedback op amp can be treated like a conventional op amp. As with a conventional op amp, the feedback network connected to the inverting input controls the closed-loop gain. But with a current-feedback op amp, the impedance of the feedback network also controls the open-loop gain and frequency response.

Feedback resistor values can be selected to provide a nearly constant closed-loop bandwidth over a very wide range of gain. This is in contrast to a conventional op amp where circuit bandwidth is inversely proportional to the closed-loop gain, sharply limiting bandwidth at high gain.

Figures 4a and 4b show appropriate feedback resistor values versus closed-loop gain for maximum bandwidth with minimal peaking. The dual vertical axes of these curves also show the resulting bandwidth. Note that the bandwidth remains nearly constant as gain is increased.

With control of the open-loop characteristics of the op amp, dynamic behavior can be tailored to an application's requirements. Lower feedback resistance gives wider bandwidth, more frequency-response peaking and more pulse response overshoot. The higher open-loop gain resulting from lower feedback network resistors also yields lower distortion. Higher feedback network resistance gives an over-damped response with little or no peaking and overshoot. This may be beneficial when driving capacitive loads. Feedback network impedance can also be varied to optimize dynamic performance. To achieve wider bandwidth, use a feedback resistor value somewhat lower than indicated in Figure 4.

EXTENDING BANDWIDTH

For gains less than approximately 20, bandwidth can be extended by adding a capacitor, C_F , in parallel with a lower value for R_F . The optimum feedback resistor value in this case is far lower than those shown in Figure 1. For $\pm 15V$ operation, select R_F with the following equation:

$$R_F (\Omega) = 30 \cdot (30 - G) \quad \text{for } V_S = \pm 15V$$

For example, for a gain of 10, use $R_F = 600\Omega$. Optimum values differ slightly for $\pm 5V$ operation:

$$R_F (\Omega) = 30 \cdot (23 - G) \quad \text{for } V_S = \pm 5V$$

C_F will range from 1pF to 10pF depending on the selected gain, load, and circuit layout. Adjust C_F to optimize bandwidth and minimize peaking. Figure 5 shows bandwidth which can be achieved using this technique.

Typical values for this capacitor range from 1pF to 10pF depending on closed-loop gain and load characteristics. Too large a value of C_F can cause instability.

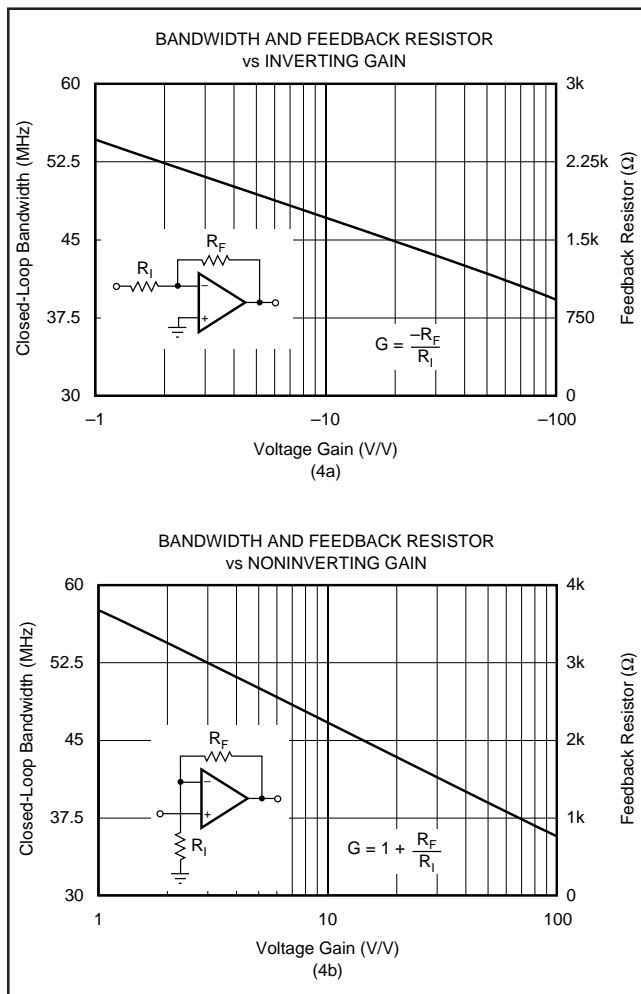

FIGURE 4. Feedback Resistor Selection Curves.

UNITY-GAIN OPERATION

As Figure 4b indicates, the OPA603 can be operated in unity gain. A feedback resistor (approximately 2.8k Ω) sets the appropriate open-loop characteristics and resistor R_1 is omitted. Just as with gains greater than one, the value of the feedback resistor (and capacitor if used) can be optimized for the desired dynamic response and load characteristics.

Care should be exercised not to exceed the maximum differential input voltage rating of $\pm 6V$. Large input voltage steps which exceed the device's slew rate of 1000V/ μ s can apply excessive differential input voltage.

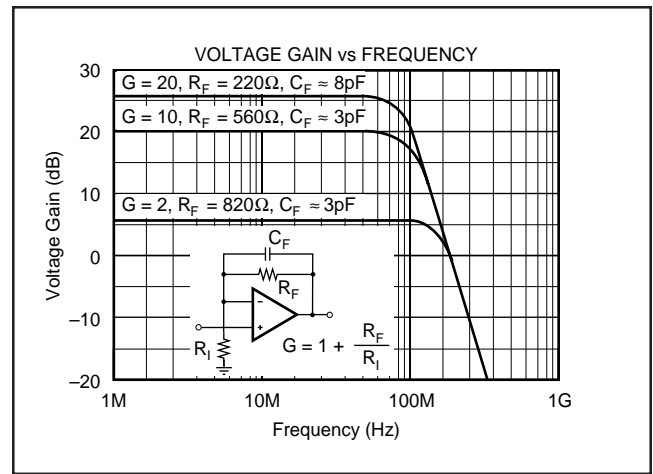

FIGURE 5. Bandwidth Results with Added Capacitor C_F .

CIRCUIT LAYOUT

With any high-speed, wide-bandwidth circuitry, careful circuit layout will ensure best performance. Make short, direct circuit interconnections and avoid stray wiring capacitance—especially at the inverting input pin. A component-side ground plane will help ensure low ground impedance. Do not place the ground plane under or near the inputs and feedback network.

Power supplies should be bypassed with good high-frequency capacitors positioned close to the op amp pins. In most cases, a 0.01 μ F ceramic capacitor in parallel with a 2.2 μ F solid tantalum capacitor at each power supply pin is adequate. The OPA603 can deliver high load current—up to 150mA peak. Applications with low impedance or capacitive loads demand large current transients from the power supplies. It is the power supply bypass capacitors which must supply these current transients. Larger bypass capacitors such as 10 μ F solid tantalum capacitors may improve performance in these applications.

POWER DISSIPATION

High output current causes increased internal power dissipation in the OPA603. Copper leadframe construction maximizes heat dissipation compared to conventional plastic packages. To achieve best heat dissipation, solder the device directly to the circuit board and use wide circuit board traces. Solder the unused pins, (1, 5 and 8) to a top-side ground plane for improved power dissipation. Limit the load and signal conditions depending on maximum ambient temperature to assure operation within the power derating curve.

The OPA603 may be operated at reduced power supply voltage to minimize power dissipation. Detailed specifications are provided for both $\pm 15V$ and $\pm 5V$ operation.

APPLICATIONS CIRCUITS

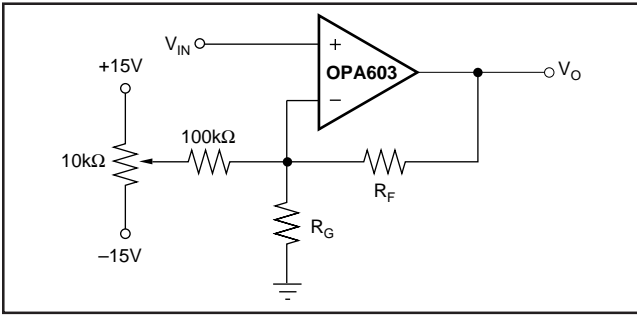

FIGURE 6. Offset Voltage Adjustment.

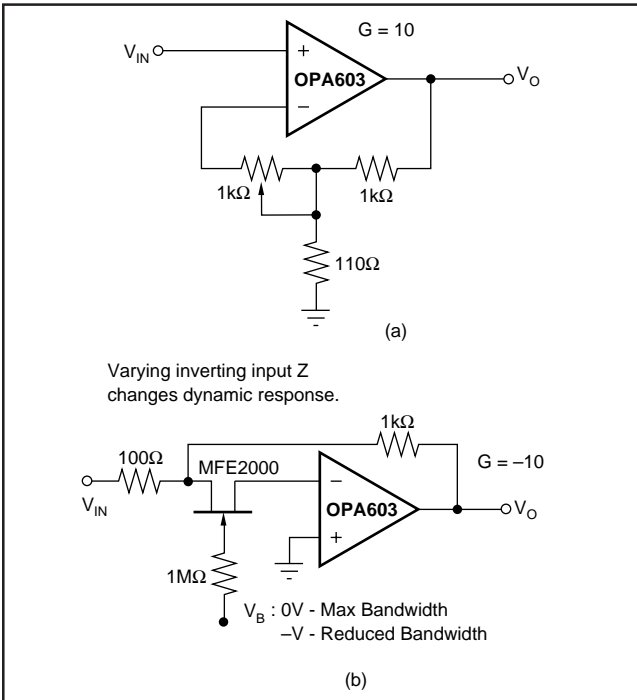

FIGURE 7. Controlling Dynamic Performance.

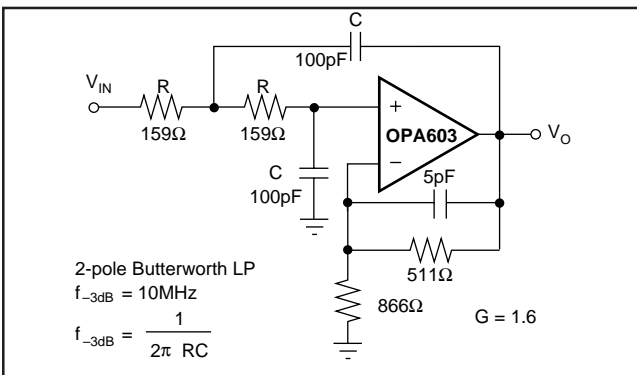

FIGURE 8. Low-Pass Filter — 10MHz.

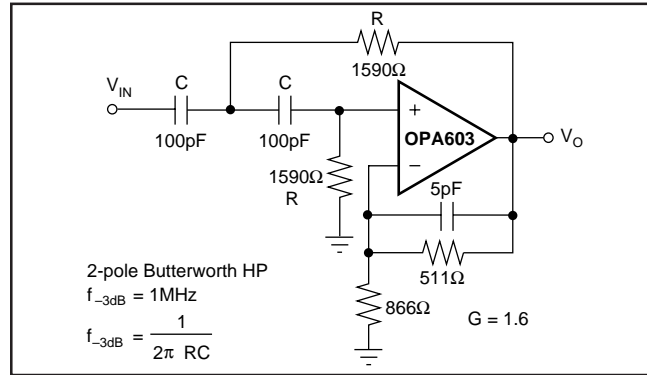

FIGURE 9. High-Pass Filter — 1MHz.

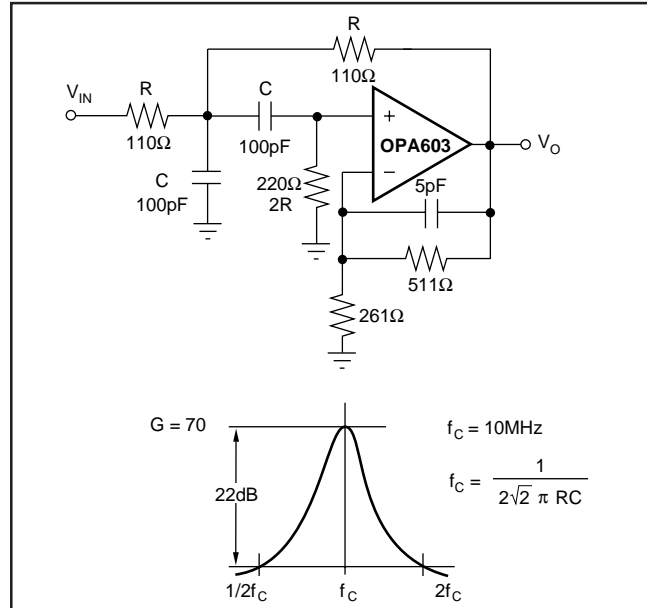

FIGURE 10. Bandpass Filter — 10MHz.

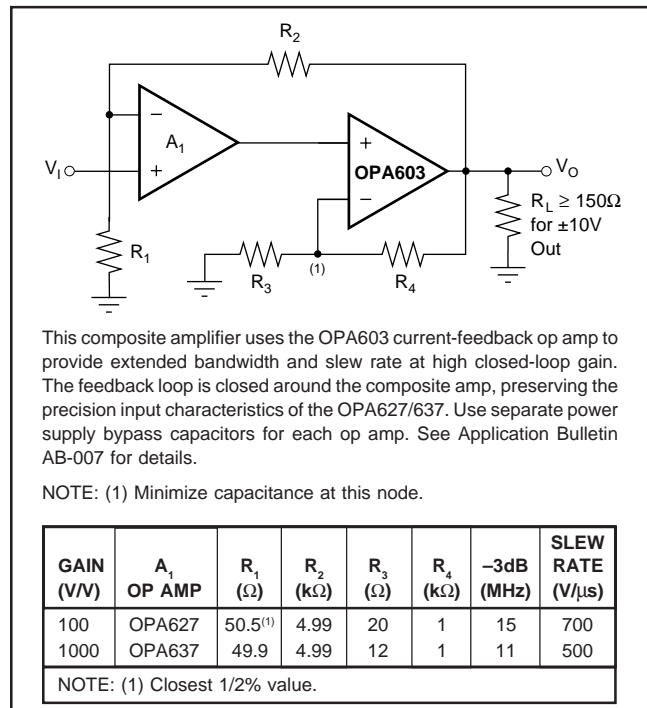

FIGURE 11. Precision-Input Composite Amplifier.

PACKAGING INFORMATION

Orderable Device	Status ⁽¹⁾	Package Type	Package Drawing	Pins	Package Qty	Eco Plan ⁽²⁾	Lead/Ball Finish	MSL Peak Temp ⁽³⁾
OPA603AP	OBSOLETE	PDIP	P	8		TBD	Call TI	Call TI
OPA603AU	OBSOLETE	SOIC	DW	16		TBD	Call TI	Call TI
OPA603AU/1K	OBSOLETE	SOIC	DW	16		TBD	Call TI	Call TI

⁽¹⁾ The marketing status values are defined as follows:

ACTIVE: Product device recommended for new designs.

LIFEBUY: TI has announced that the device will be discontinued, and a lifetime-buy period is in effect.

NRND: Not recommended for new designs. Device is in production to support existing customers, but TI does not recommend using this part in a new design.

PREVIEW: Device has been announced but is not in production. Samples may or may not be available.

OBSOLETE: TI has discontinued the production of the device.

⁽²⁾ Eco Plan - The planned eco-friendly classification: Pb-Free (RoHS) or Green (RoHS & no Sb/Br) - please check <http://www.ti.com/productcontent> for the latest availability information and additional product content details.

TBD: The Pb-Free/Green conversion plan has not been defined.

Pb-Free (RoHS): TI's terms "Lead-Free" or "Pb-Free" mean semiconductor products that are compatible with the current RoHS requirements for all 6 substances, including the requirement that lead not exceed 0.1% by weight in homogeneous materials. Where designed to be soldered at high temperatures, TI Pb-Free products are suitable for use in specified lead-free processes.

Green (RoHS & no Sb/Br): TI defines "Green" to mean Pb-Free (RoHS compatible), and free of Bromine (Br) and Antimony (Sb) based flame retardants (Br or Sb do not exceed 0.1% by weight in homogeneous material)

⁽³⁾ MSL, Peak Temp. -- The Moisture Sensitivity Level rating according to the JEDEC industry standard classifications, and peak solder temperature.

Important Information and Disclaimer:The information provided on this page represents TI's knowledge and belief as of the date that it is provided. TI bases its knowledge and belief on information provided by third parties, and makes no representation or warranty as to the accuracy of such information. Efforts are underway to better integrate information from third parties. TI has taken and continues to take reasonable steps to provide representative and accurate information but may not have conducted destructive testing or chemical analysis on incoming materials and chemicals. TI and TI suppliers consider certain information to be proprietary, and thus CAS numbers and other limited information may not be available for release.

In no event shall TI's liability arising out of such information exceed the total purchase price of the TI part(s) at issue in this document sold by TI to Customer on an annual basis.

IMPORTANT NOTICE

Texas Instruments Incorporated and its subsidiaries (TI) reserve the right to make corrections, modifications, enhancements, improvements, and other changes to its products and services at any time and to discontinue any product or service without notice. Customers should obtain the latest relevant information before placing orders and should verify that such information is current and complete. All products are sold subject to TI's terms and conditions of sale supplied at the time of order acknowledgment.

TI warrants performance of its hardware products to the specifications applicable at the time of sale in accordance with TI's standard warranty. Testing and other quality control techniques are used to the extent TI deems necessary to support this warranty. Except where mandated by government requirements, testing of all parameters of each product is not necessarily performed.

TI assumes no liability for applications assistance or customer product design. Customers are responsible for their products and applications using TI components. To minimize the risks associated with customer products and applications, customers should provide adequate design and operating safeguards.

TI does not warrant or represent that any license, either express or implied, is granted under any TI patent right, copyright, mask work right, or other TI intellectual property right relating to any combination, machine, or process in which TI products or services are used. Information published by TI regarding third-party products or services does not constitute a license from TI to use such products or services or a warranty or endorsement thereof. Use of such information may require a license from a third party under the patents or other intellectual property of the third party, or a license from TI under the patents or other intellectual property of TI.

Reproduction of information in TI data books or data sheets is permissible only if reproduction is without alteration and is accompanied by all associated warranties, conditions, limitations, and notices. Reproduction of this information with alteration is an unfair and deceptive business practice. TI is not responsible or liable for such altered documentation.

Resale of TI products or services with statements different from or beyond the parameters stated by TI for that product or service voids all express and any implied warranties for the associated TI product or service and is an unfair and deceptive business practice. TI is not responsible or liable for any such statements.

Following are URLs where you can obtain information on other Texas Instruments products and application solutions:

Products		Applications	
Amplifiers	amplifier.ti.com	Audio	www.ti.com/audio
Data Converters	dataconverter.ti.com	Automotive	www.ti.com/automotive
DSP	dsp.ti.com	Broadband	www.ti.com/broadband
Interface	interface.ti.com	Digital Control	www.ti.com/digitalcontrol
Logic	logic.ti.com	Military	www.ti.com/military
Power Mgmt	power.ti.com	Optical Networking	www.ti.com/opticalnetwork
Microcontrollers	microcontroller.ti.com	Security	www.ti.com/security
		Telephony	www.ti.com/telephony
		Video & Imaging	www.ti.com/video
		Wireless	www.ti.com/wireless

Mailing Address: Texas Instruments
Post Office Box 655303 Dallas, Texas 75265