

OPA404

Quad High-Speed Precision *Difet*[®] OPERATIONAL AMPLIFIER

FEATURES

- WIDE BANDWIDTH: 6.4MHz
- HIGH SLEW RATE: 35V/ μ s
- LOW OFFSET: $\pm 750\mu$ V max
- LOW BIAS CURRENT: ± 4 pA max
- LOW SETTLING: 1.5 μ s to 0.01%
- STANDARD QUAD PINOUT

APPLICATIONS

- PRECISION INSTRUMENTATION
- OPTOELECTRONICS
- SONAR, ULTRASOUND
- PROFESSIONAL AUDIO EQUIPMENT
- MEDICAL EQUIPMENT
- DETECTOR ARRAYS

DESCRIPTION

The OPA404 is a high performance monolithic *Difet*[®] (dielectrically-isolated FET) quad operational amplifier. It offers an unusual combination of very-low bias current together with wide bandwidth and fast slew rate.

Noise, bias current, voltage offset, drift, and speed are superior to BIFET[®] amplifiers.

Laser-trimming of thin-film resistors gives very low offset and drift—the best available in a quad FET op amp.

The OPA404's input cascode design allows high precision input specifications and uncompromised high-speed performance.

Standard quad op amp pin configuration allows upgrading of existing designs to higher performance levels. The OPA404 is unity-gain stable.

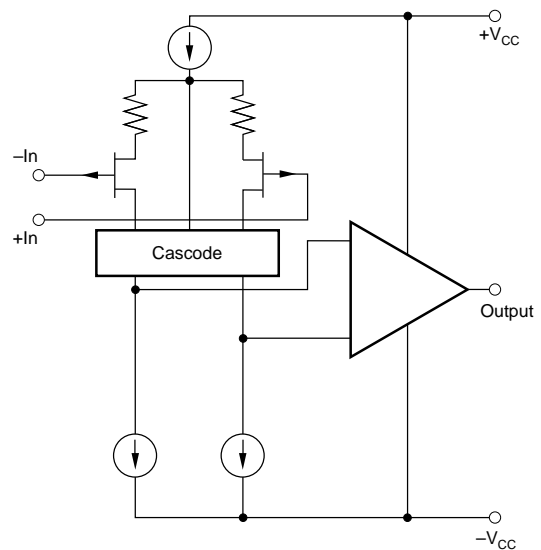

OPA404 Simplified Circuit
(Each Amplifier)

Difet[®], Burr-Brown Corp.
BIFET[®], National Semiconductor Corp.

International Airport Industrial Park • Mailing Address: PO Box 11400 • Tucson, AZ 85734 • Street Address: 6730 S. Tucson Blvd. • Tucson, AZ 85706
Tel: (520) 746-1111 • Twx: 910-952-1111 • Cable: BBRCORP • Telex: 066-6491 • FAX: (520) 889-1510 • Immediate Product Info: (800) 548-6132

SPECIFICATIONS

ELECTRICAL

At $V_{CC} = \pm 15\text{VDC}$ and $T_A = +25^\circ\text{C}$ unless otherwise noted.

PARAMETER	CONDITIONS	OPA404AG, KP, KU ⁽¹⁾			OPA404BG			OPA404SG			UNITS
		MIN	TYP	MAX	MIN	TYP	MAX	MIN	TYP	MAX	
INPUT NOISE Voltage: $f_o = 10\text{Hz}$ $f_o = 100\text{Hz}$ $f_o = 1\text{kHz}$ $f_o = 10\text{kHz}$ $f_B = 10\text{Hz to } 10\text{kHz}$ $f_B = 0.1\text{Hz to } 10\text{Hz}$ Current: $f_B = 0.1\text{Hz to } 10\text{Hz}$ $f_o = 0.1\text{Hz thru } 20\text{kHz}$			32			*			*		$\text{nV}/\sqrt{\text{Hz}}$
				19			*		*		$\text{nV}/\sqrt{\text{Hz}}$
				15			*		*		$\text{nV}/\sqrt{\text{Hz}}$
				12			*		*		$\text{nV}/\sqrt{\text{Hz}}$
				1.4			*		*		μVrms
				0.95			*		*		$\mu\text{Vp-p}$
				12			*		*		fA, p-p
			0.6			*		*		$\text{fA}/\sqrt{\text{Hz}}$	
OFFSET VOLTAGE Input Offset Voltage KP, KU Average Drift KP, KU Supply Rejection KP, KU Channel Separation	$V_{CM} = 0\text{VDC}$		± 260 ± 750	$\pm 1\text{mV}$ $\pm 2.5\text{mV}$		*	± 750		*	*	μV μV
	$T_A = T_{MIN}$ to T_{MAX}		± 3 ± 5			*			*		$\mu\text{V}/^\circ\text{C}$ $\mu\text{V}/^\circ\text{C}$
	$\pm V_{CC} = 12\text{V to } 18\text{V}$	80 76	100 100		86	*		*	*		dB dB
	$100\text{Hz, } R_L = 2\text{k}\Omega$		125			*			*		dB
							*			*	
BIAS CURRENT Input Bias Current KP, KU	$V_{CM} = 0\text{VDC}$		± 1 ± 1	± 8 ± 12		*	± 4		*	*	pA pA
						*			*	*	
OFFSET CURRENT Input Offset Current KP, KU	$V_{CM} = 0\text{VDC}$		0.5 0.5	8 12		*	4		*	*	pA pA
						*			*	*	
IMPEDANCE Differential Common-Mode			$10^{13} \parallel 1$ $10^{14} \parallel 3$			*			*		$\Omega \parallel \text{pF}$ $\Omega \parallel \text{pF}$
						*			*		
VOTAGE RANGE Common-Mode Input Range Common-Mode Rejection KP, KU	$V_{IN} = \pm 10\text{VDC}$	± 10.5 88 84	$+13, -11$ 100 100		*	*		*	*		V dB dB
						*			*		
						*			*		
OPEN-LOOP GAIN, DC Open-Loop Voltage Gain	$R_L \geq 2\text{k}\Omega$	88	100		92	*		*	*		dB
FREQUENCY RESPONSE Gain Bandwidth Full Power Response Slew Rate Settling Time: 0.1% 0.01%	Gain = 100 $20\text{Vp-p, } R_L = 2\text{k}\Omega$	4	6.4 570		5	*		*	*		MHz kHz
	$V_O = \pm 10\text{V, } R_L = 2\text{k}\Omega$	24	35		28	*		*	*		$\text{V}/\mu\text{s}$
	Gain = -1, $R_L = 2\text{k}\Omega$		0.6			*		*	*		μs
	$C_L = 100\text{ pF, } 10\text{V Step}$		1.5			*		*	*		μs
							*		*	*	
RATED OUTPUT Voltage Output Current Output Output Resistance Load Capacitance Stability Short Circuit Current	$R_L = 2\text{k}\Omega$ $V_O = \pm 10\text{VDC}$ 1MHz, Open Loop Gain = +1	± 11.5 ± 5	$+13.2, -13.8$ ± 10 80 1000		*	*		*	*		V mA Ω pF mA
				± 40	*	*	*	*	*	*	
						*	*		*	*	
						*	*		*	*	
						*	*		*	*	
POWER SUPPLY Rated Voltage Voltage Range, Derated Performance Current, Quiescent			± 15			*		*	*		VDC
		± 5		± 18	*		*	*	*		VDC
	$I_O = 0\text{mADC}$		9	10		*	*	*	*		mA
TEMPERATURE RANGE Specification KP, KU Operating KP, KU Storage KP, KU θ Junction-Ambient KP, KU	Ambient Temperature	-25 0		+85 +70	*		*	-55		+125	$^\circ\text{C}$ $^\circ\text{C}$
	Ambient Temperature	-55		+125	*		*	*		*	$^\circ\text{C}$
	Ambient Temperature	-25		+85	*		*	*		*	$^\circ\text{C}$
	Ambient Temperature	-65		+150	*		*	*		*	$^\circ\text{C}$
	Ambient Temperature	-40		+125						*	$^\circ\text{C}$
			100			*		*		*	$^\circ\text{C}/\text{W}$
			120/100							*	$^\circ\text{C}/\text{W}$

*Specifications same as OPA404AG.

NOTE: (1) OPA404KU may be marked OPA404U.

The information provided herein is believed to be reliable; however, BURR-BROWN assumes no responsibility for inaccuracies or omissions. BURR-BROWN assumes no responsibility for the use of this information, and all use of such information shall be entirely at the user's own risk. Prices and specifications are subject to change without notice. No patent rights or licenses to any of the circuits described herein are implied or granted to any third party. BURR-BROWN does not authorize or warrant any BURR-BROWN product for use in life support devices and/or systems.

ELECTRICAL (FULL TEMPERATURE RANGE SPECIFICATIONS)

At $V_{CC} = \pm 15\text{VDC}$ and $T_A = T_{MIN}$ to T_{MAX} unless otherwise noted.

PARAMETER	CONDITIONS	OPA404AG, KP, KU			OPA404BG			OPA404SG			UNITS
		MIN	TYP	MAX	MIN	TYP	MAX	MIN	TYP	MAX	
TEMPERATURE RANGE Specification Range KP, KU	Ambient Temperature	-25 0		+85 +70	*		*	-55		+125	°C °C
INPUT OFFSET VOLTAGE Input Offset Voltage KP KU Average Drift KP, KU Supply Rejection	$V_{CM} = 0\text{VDC}$		± 450 ± 1 ± 3 ± 5 96	2mV ± 3.5		*	$\pm 1.5\text{mV}$		± 550 *	$\pm 2.5\text{mV}$	μV mV $\mu\text{V}/^\circ\text{C}$ $\mu\text{V}/^\circ\text{C}$ dB
BIAS CURRENT Input Bias Current	$V_{CM} = 0\text{VDC}$		± 32	± 200		*	± 100		± 500	$\pm 5\text{nA}$	pA
OFFSET CURRENT Input Offset Current	$V_{CM} = 0\text{VDC}$		17	100		*	50		260	2.5nA	pA
VOLTAGE RANGE Common-Mode Input Range Common-Mode Rejection KP, KU	$V_{IN} = \pm 10\text{VDC}$	± 10 82 80	$\pm 12.7, -10.6$ 99 99		*	*		± 10 80	$+12.6, -10.5$ 88		V dB dB
OPEN-LOOP GAIN, DC Open-Loop Voltage Gain	$R_L \geq 2\text{k}\Omega$	82	94		86	*		80	88		dB
RATED OUTPUT Voltage Output Current Output Short Circuit Current	$R_L = 2\text{k}\Omega$ $V_O = \pm 10\text{VDC}$ $V_O = 0\text{VDC}$	± 11.5 ± 5 ± 8	$\pm 12.9, -13.8$ ± 9 ± 20	± 50	*	*	*	± 11 *	$+12.7, -13.8$ ± 8 *		V mA mA
POWER SUPPLY Current, Quiescent	$I_O = 0\text{mADC}$		9.3	10.5		*	*		9.4	11	mA

* Specification same as OPA404AG.

ORDERING INFORMATION

MODEL	PACKAGE	TEMPERATURE RANGE
OPA404KP	14-Pin Plastic DIP	0°C to +70°C
OPA404KU ⁽¹⁾	16-Pin Plastic SOIC	0°C to +70°C
OPA404AG	14-Pin Ceramic DIP	-25°C to +85°C
OPA404BG	14-Pin Ceramic DIP	-25°C to +85°C
OPA404SG	14-Pin Ceramic DIP	-55°C to +125°C

NOTE: (1) OPA404KU may be marked OPA404U.

PACKAGE INFORMATION

MODEL	PACKAGE	PACKAGE DRAWING NUMBER ⁽¹⁾
OPA404KP	14-Pin Plastic DIP	010
OPA404KU ⁽²⁾	16-Pin Plastic SOIC	211
OPA404AG	14-Pin Ceramic DIP	169
OPA404BG	14-Pin Ceramic DIP	169
OPA404SG	14-Pin Ceramic DIP	169

NOTE: (1) For detailed drawing and dimension table, please see end of data sheet, or Appendix D of Burr-Brown IC Data Book. (2) OPA404KU may be marked OPA404U.

ABSOLUTE MAXIMUM RATINGS

Supply	$\pm 18\text{VDC}$	Operating Temperature Range .. P, U = -25°C/+85°C, G = -55°C/+125°C	
Internal Power Dissipation ⁽¹⁾	1000mW	Lead Temperature (soldering, 10s)	300°C
Differential Input Voltage ⁽²⁾	$\pm 36\text{VDC}$	SOIC (soldering, 3s)	+260°C
Input Voltage Range ⁽²⁾	$\pm 18\text{VDC}$	Output Short-Circuit Duration ⁽³⁾	Continuous
Storage Temperature Range ... P, U = -40°C/+125°C, G = -65°C/+150°C		Junction Temperature	+175°C

NOTES: (1) Packages must be derated based on $\theta_{JC} = 30^\circ\text{C/W}$ or $\theta_{JA} = 120^\circ\text{C/W}$. (2) For supply voltages less than $\pm 18\text{VDC}$ the absolute maximum input voltage is equal to: $18\text{V} > V_{IN} > -V_{CC} - 8\text{V}$. See Figure 2. (3) Short circuit may be to power supply common only. Rating applies to +25°C ambient. Observe dissipation limit and T_J .

PIN CONFIGURATION

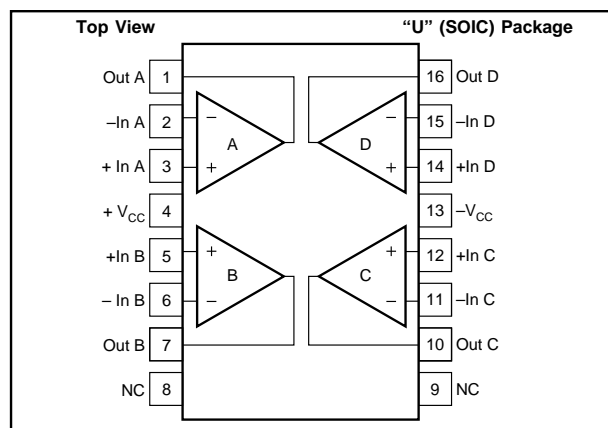
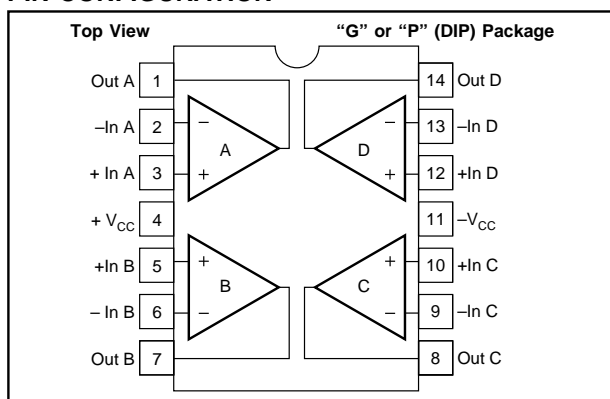

DICE INFORMATION

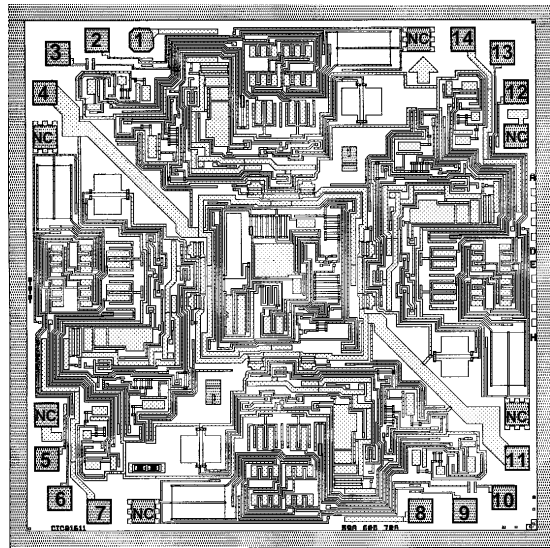

OPA404 DIE TOPOGRAPHY

PAD	FUNCTION	PAD	FUNCTION
1	Output A	8	Output C
2	-Input A	9	-Input C
3	+Input A	10	+Input C
4	+V _{CC}	11	-V _{CC}
5	+Input B	12	+Input D
6	-Input B	13	-Input D
7	Output B	14	Output D

Substrate Bias: -V_{CC}
 NC: No connection

MECHANICAL INFORMATION

	MILS (0.001")	MILLIMETERS
Die Size	108 x 108 ±5	2.74 x 2.74 ±0.13
Die Thickness	20 ±3	0.51 ±0.08
Min. Pad Size	4 x 4	0.10 x 0.10
Backing	None	

TYPICAL PERFORMANCE CURVES

T_A = +25°C, V_{CC} = ±15VDC unless otherwise noted.

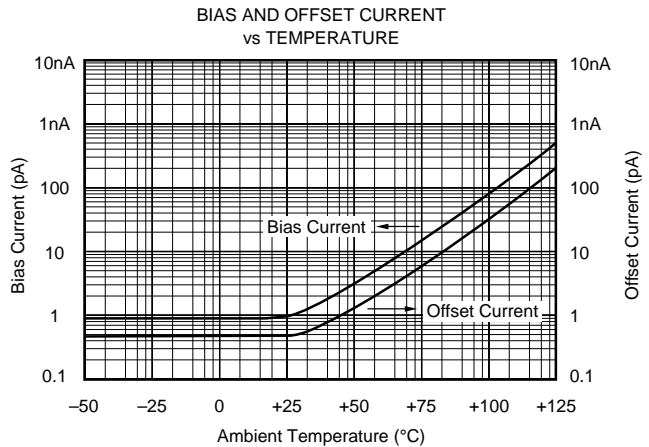
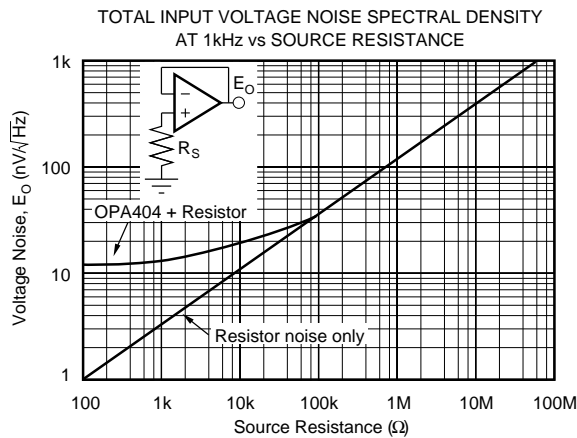
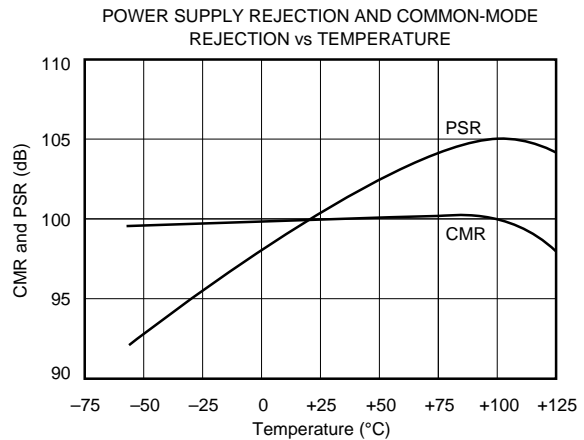
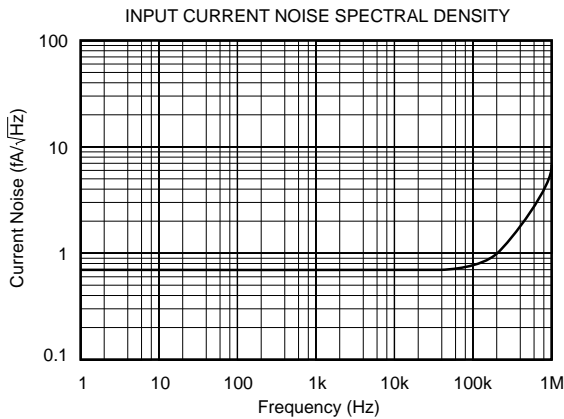

TYPICAL PERFORMANCE CURVES (CONT)

$T_A = +25^\circ\text{C}$, $V_{CC} = \pm 15\text{VDC}$ unless otherwise noted.

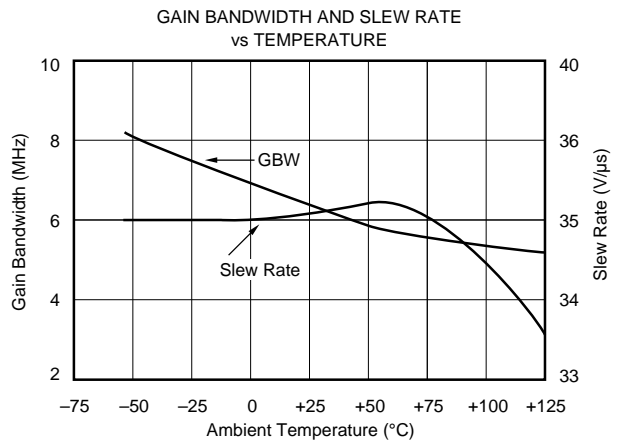
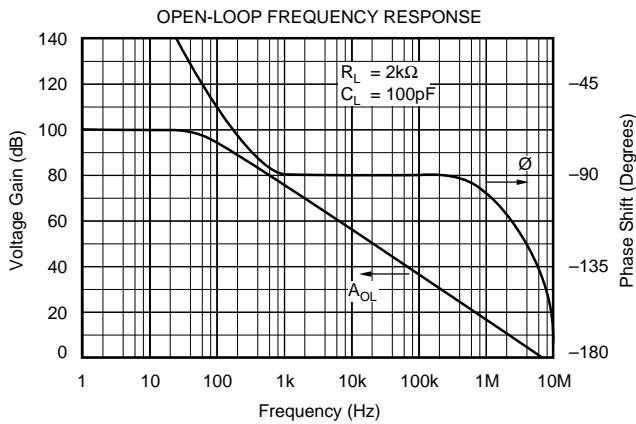
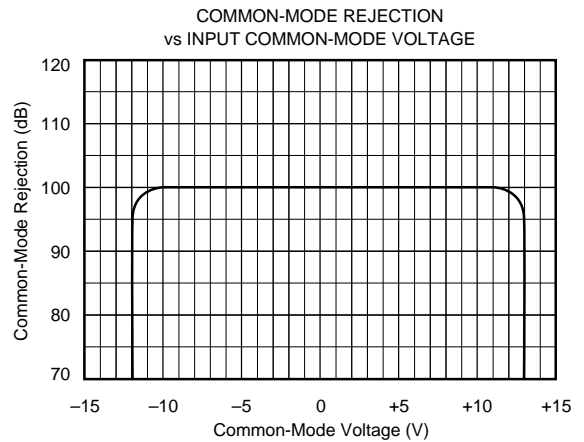
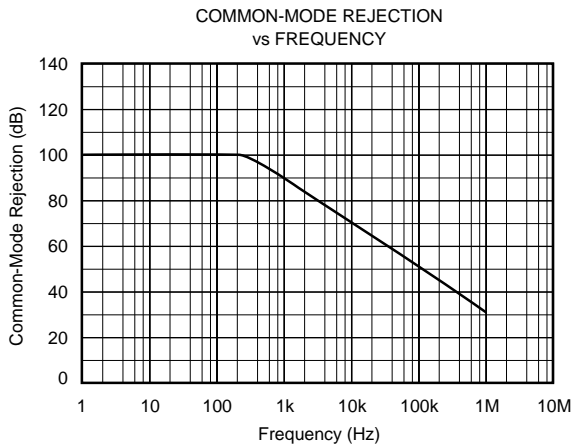
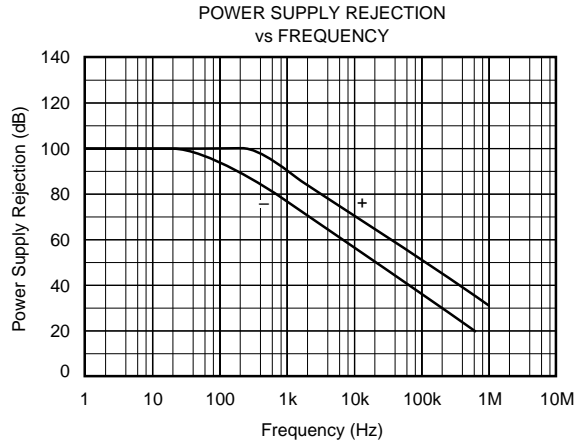
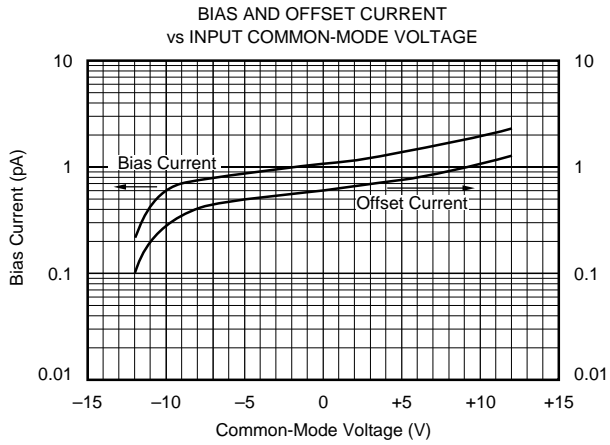

TYPICAL PERFORMANCE CURVES (CONT)

$T_A = +25^\circ\text{C}$, $V_{CC} = \pm 15\text{VDC}$ unless otherwise noted.

GAIN-BANDWIDTH AND SLEW RATE vs SUPPLY VOLTAGE

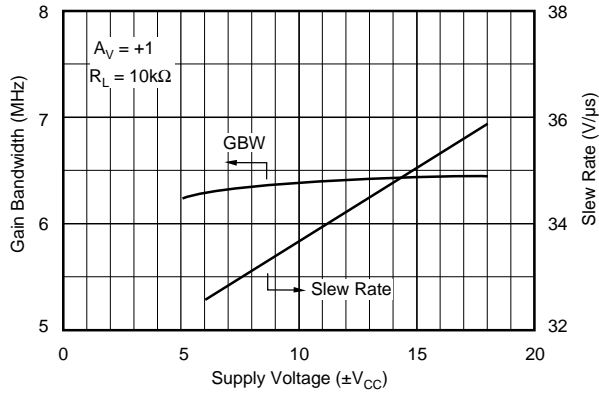

OPEN-LOOP GAIN vs TEMPERATURE

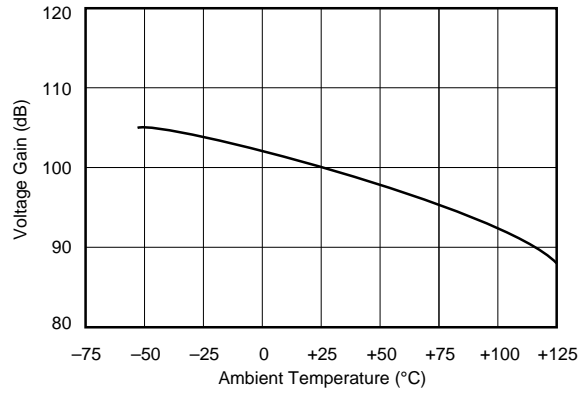

MAXIMUM OUTPUT VOLTAGE SWING vs FREQUENCY

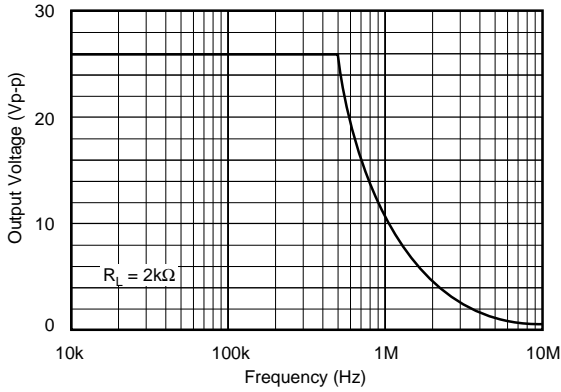

LARGE SIGNAL TRANSIENT RESPONSE

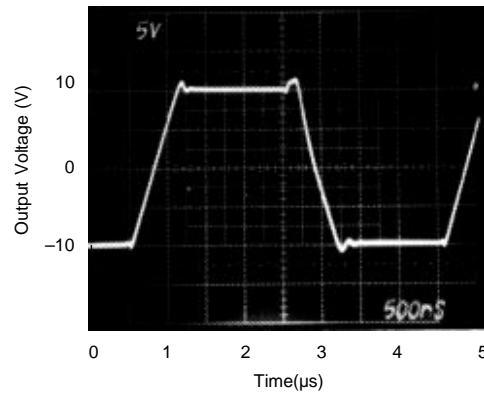

SMALL SIGNAL TRANSIENT RESPONSE

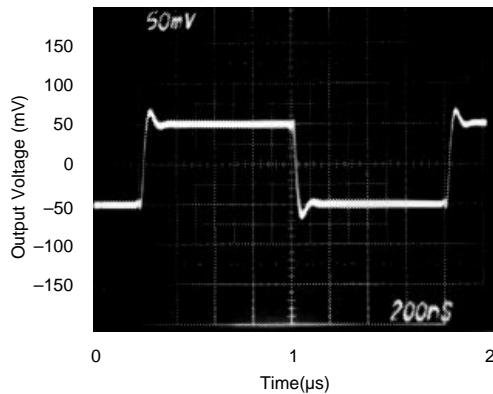

SETTLING TIME vs CLOSED-LOOP GAIN

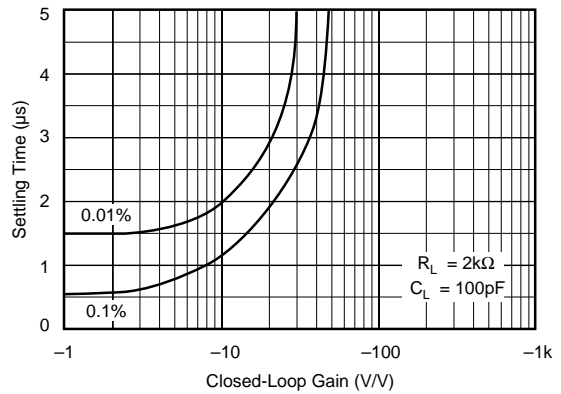

TYPICAL PERFORMANCE CURVES (CONT)

$T_A = +25^\circ\text{C}$, $V_{CC} = \pm 15\text{VDC}$ unless otherwise noted.

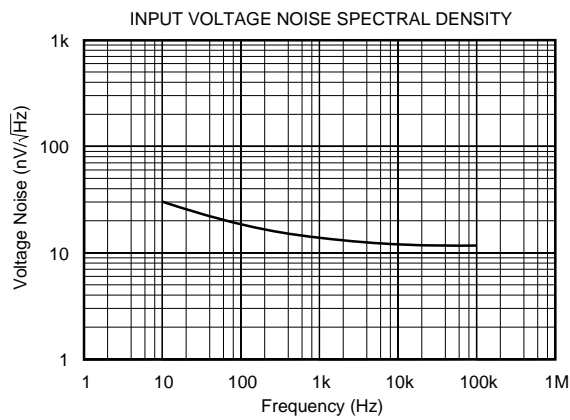
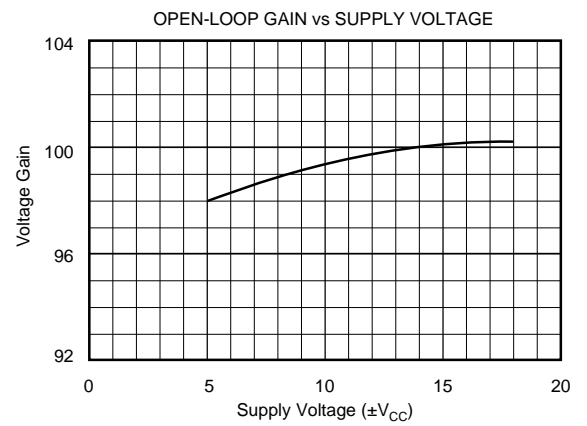
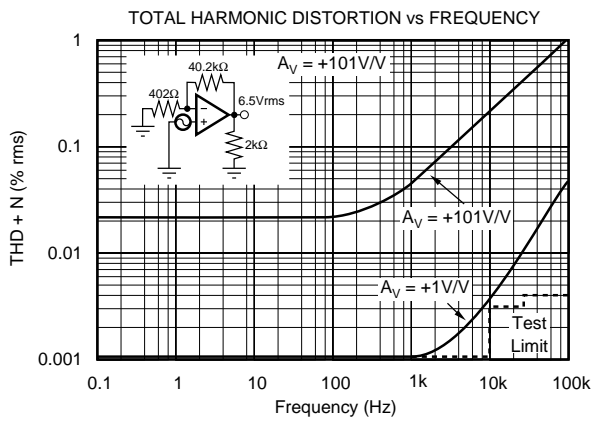
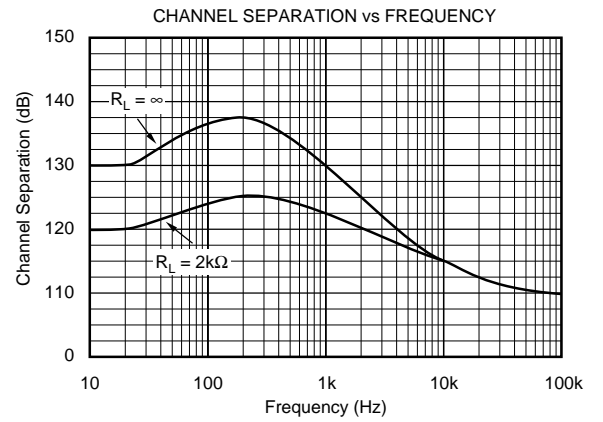
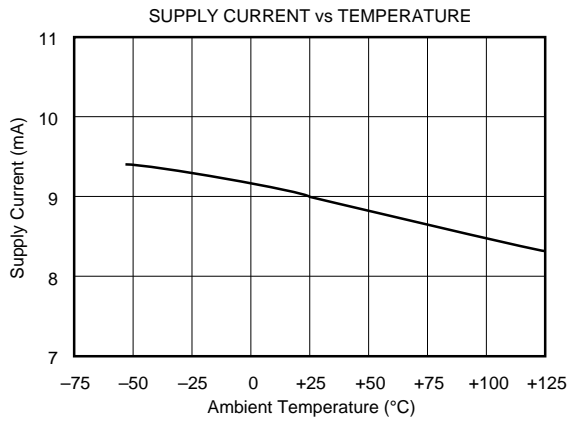

APPLICATIONS INFORMATION

OFFSET VOLTAGE ADJUSTMENT

The OPA404 offset voltage is laser-trimmed and will require no further trim for most applications. If desired, offset voltage can be trimmed by summing (see Figure 1). With this trim method there will be no degradation of input offset drift.

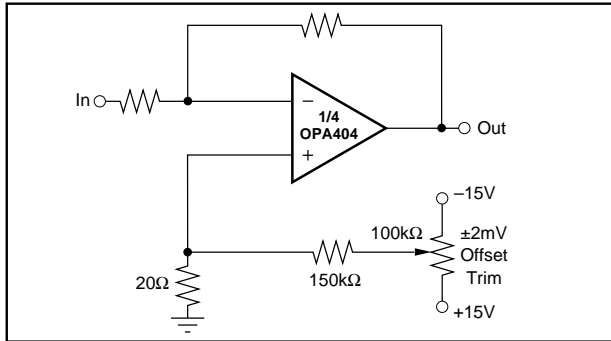

FIGURE 1. Offset Voltage Trim.

INPUT PROTECTION

Conventional monolithic FET operational amplifiers require external current-limiting resistors to protect their inputs against destructive currents that can flow when input FET gate-to-substrate isolation diodes are forward-biased. Most BIFET amplifiers can be destroyed by the loss of $-V_{CC}$.

Unlike BIFET amplifiers, the *Difet* OPA404 requires input current limiting resistors only if its input voltage is greater than 8 volts more negative than $-V_{CC}$. A 10kΩ series resistor will limit the input current to a safe value with up to $\pm 15V$ input levels even if both supply voltages are lost. (See Figure 2 and Absolute Maximum Ratings).

Static damage can cause subtle changes in amplifier input characteristics without necessarily destroying the device. In precision operational amplifiers (both bipolar and FET types), this may cause a noticeable degradation of offset voltage and drift.

Static protection is recommended when handling any precision IC operational amplifier.

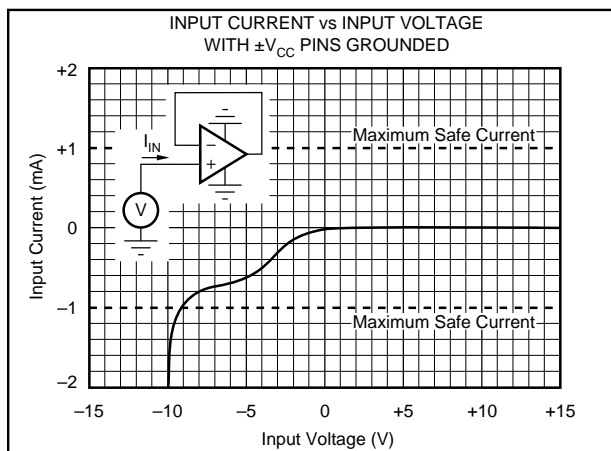

FIGURE 2. Input Current vs Input Voltage with $\pm V_{CC}$ Pins Grounded.

GUARDING AND SHIELDING

As in any situation where high impedances are involved, careful shielding is required to reduce “hum” pickup in input leads. If large feedback resistors are used, they should also be shielded along with the external input circuitry.

Leakage currents across printed circuit boards can easily exceed the bias current of the OPA404. To avoid leakage, utmost care must be used in planning the board layout. A “guard” pattern should completely surround the high impedance input leads and should be connected to a low-impedance point which is at the signal input potential. (See Figure 3).

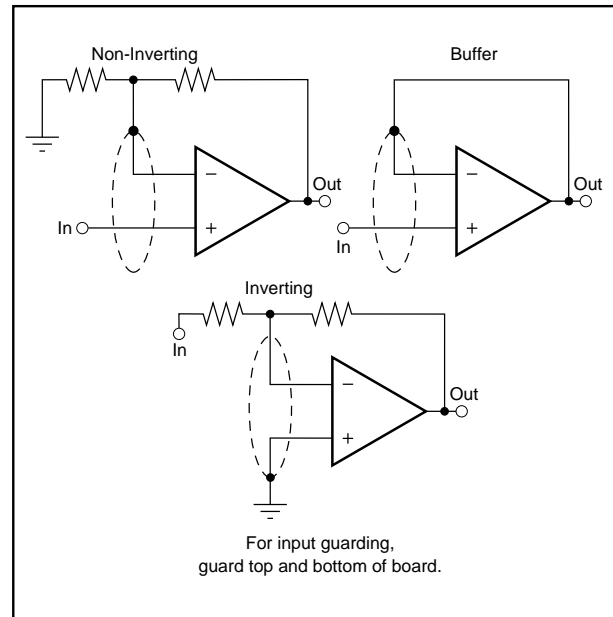

FIGURE 3. Connection of Input Guard.

HANDLING AND TESTING

Measuring the unusually low bias current of the OPA404 is difficult without specialized test equipment; most commercial benchtop testers cannot accurately measure the OPA404 bias current. Low-leakage test sockets and special test fixtures are recommended if incoming inspection of bias current is to be performed.

To prevent surface leakage between pins, the DIP package should not be handled by bare fingers. Oils and salts from fingerprints or careless handling can create leakage currents that exceed the specified OPA404 bias currents.

If necessary, DIP packages and PC board assemblies can be cleaned with Freon TF®, baked for 30 minutes at 85°C, rinsed with de-ionized water, and baked again for 30 minutes at 85°C. Surface contamination can be prevented by the application of a high-quality conformal coating to the cleaned PC board assembly.

BIAS CURRENT CHANGE vs COMMON-MODE VOLTAGE

The input bias currents of most popular BIFET operational amplifiers are affected by common-mode voltage (Figure 4). Higher input FET gate-to-drain voltage causes leakage and ionization (bias) currents to increase. Due to its cascode input stage, the extremely low bias current of the OPA404 is not compromised by common-mode voltage.

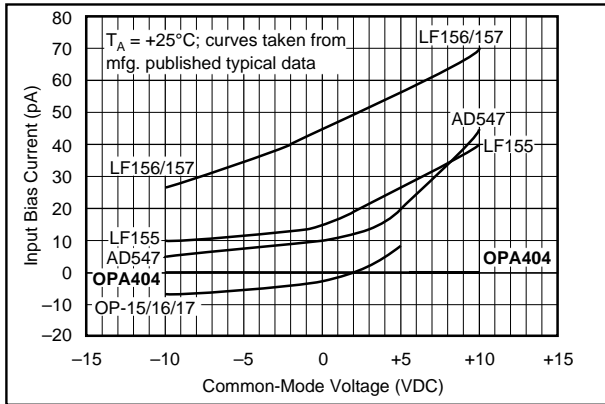

FIGURE 4. Input Bias Current vs Common-Mode Voltage.

APPLICATIONS CIRCUITS

Figures 5 through 11 are circuit diagrams of various applications for the OPA404.

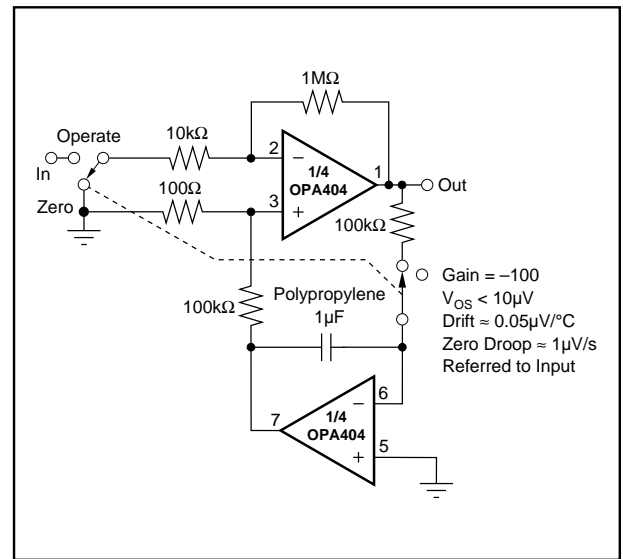

FIGURE 5. Auto-Zero Amplifier.

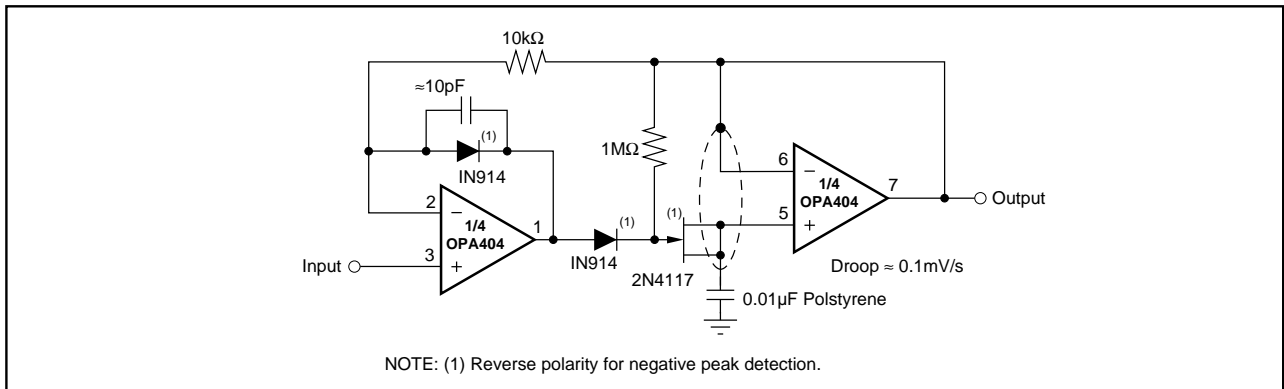

FIGURE 6. Low-Droop Positive Peak Detector.

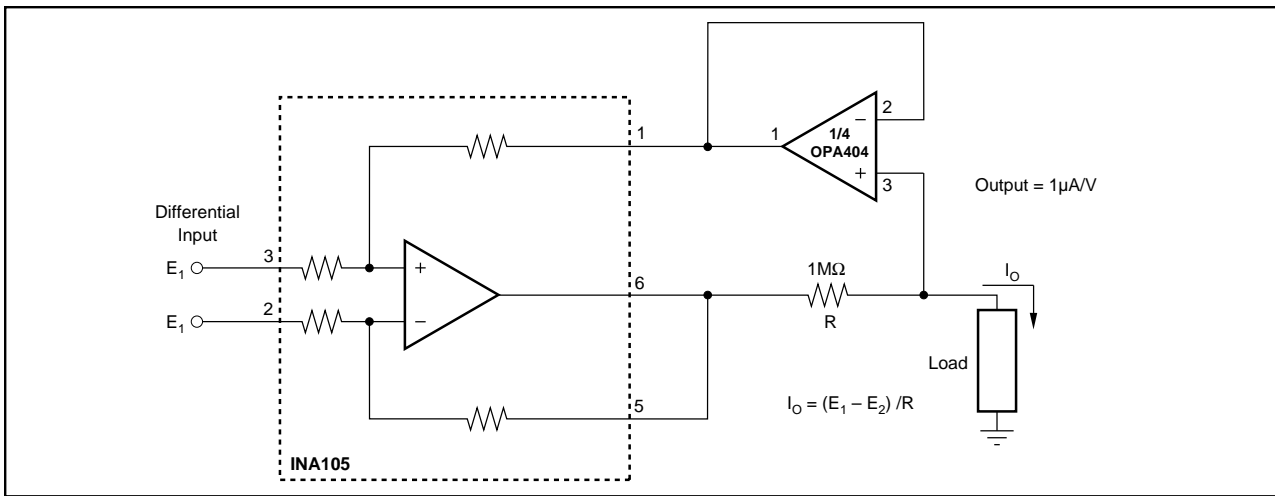

FIGURE 7. Voltage-Controlled Microamp Current Source.

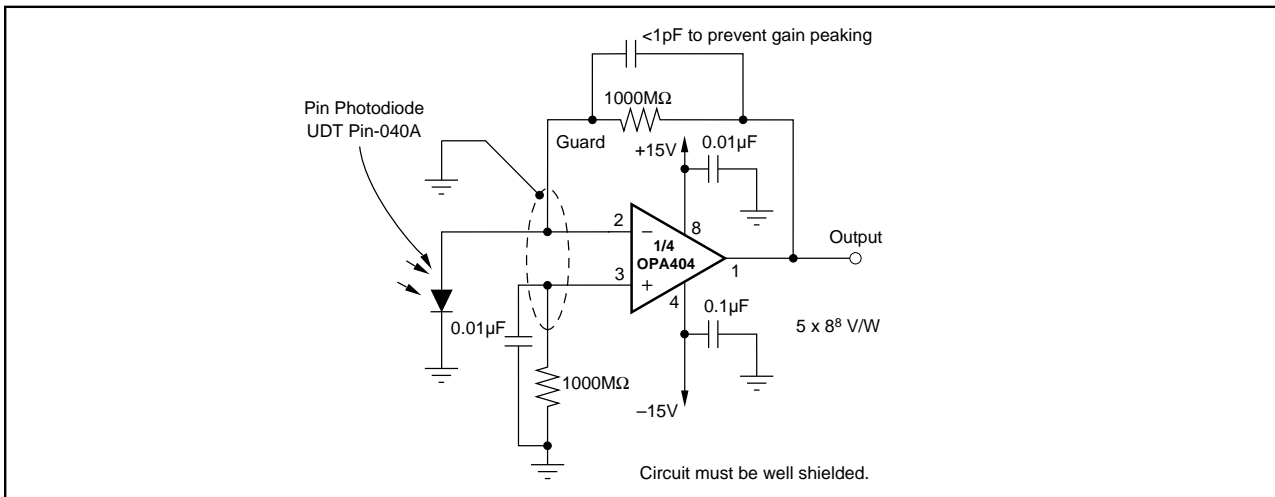

FIGURE 8. Sensitive Photodiode Amplifier.

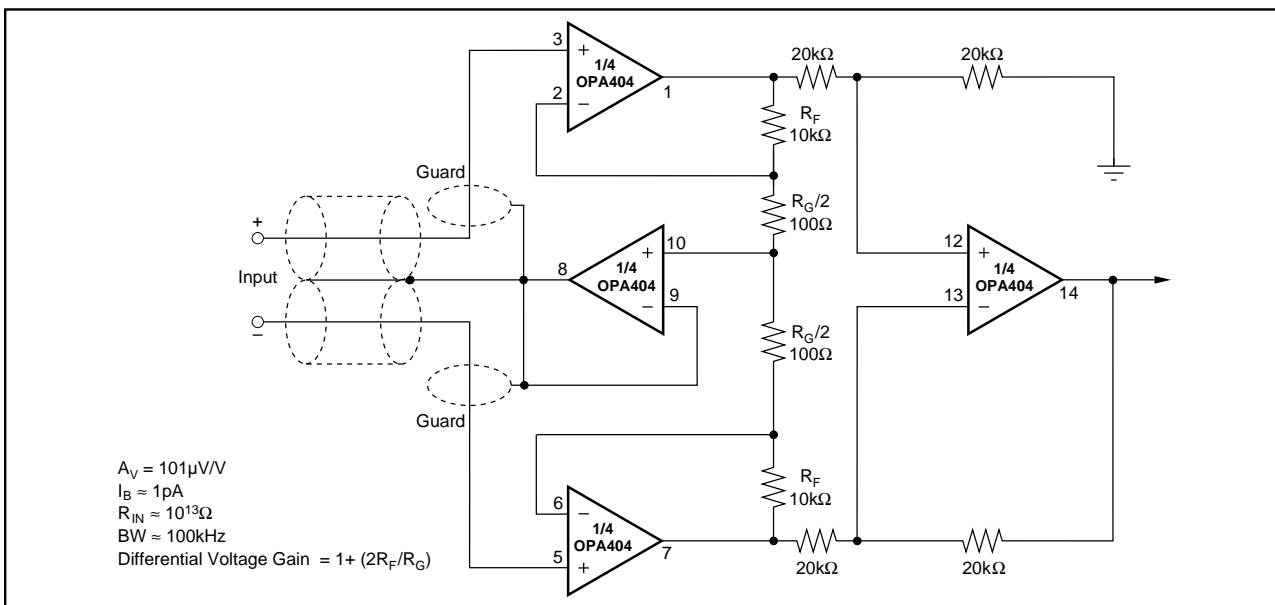

FIGURE 9. FET Instrumentation Amplifier with Shield Driver.

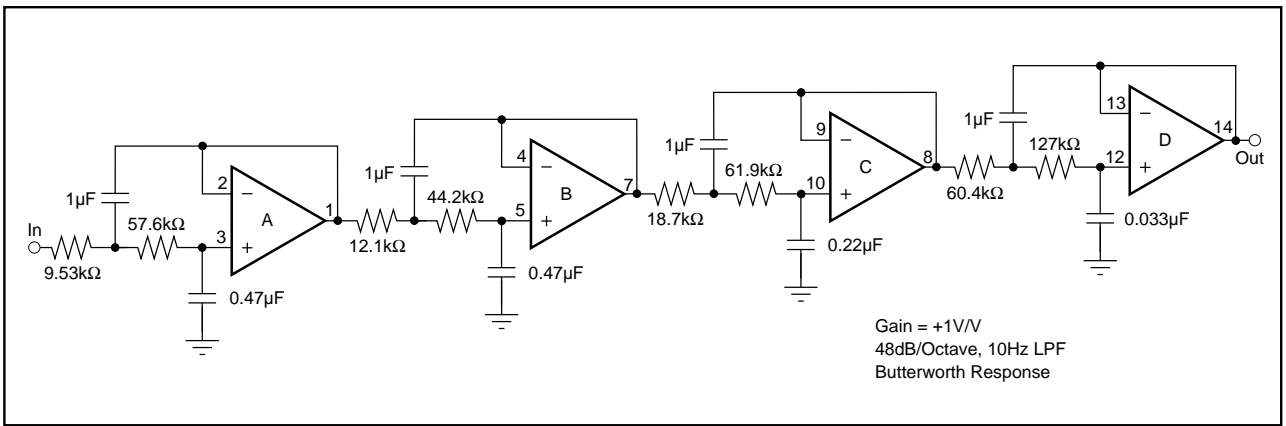

FIGURE 10. 8-Pole 10Hz Low-Pass Filter.

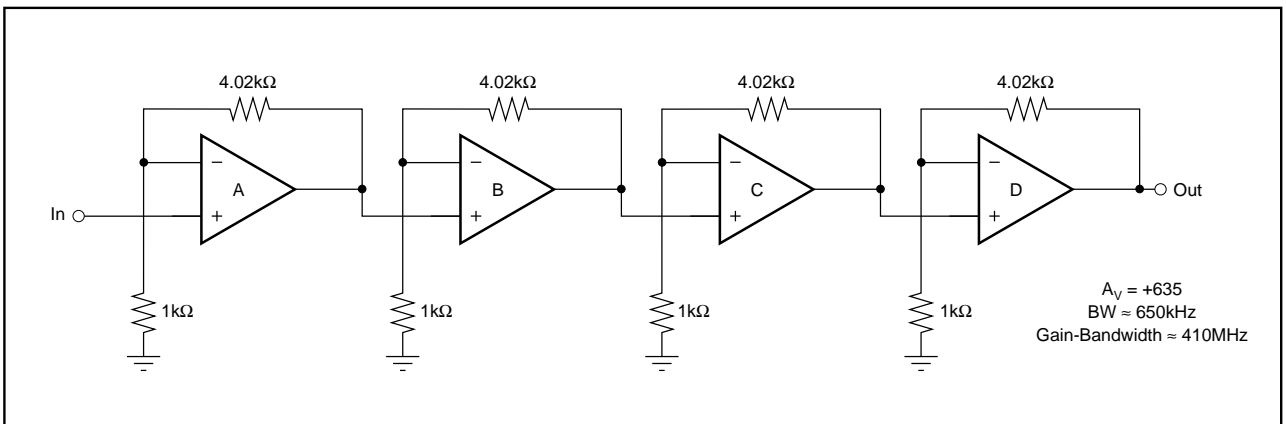

FIGURE 11. Wide-Band Amplifier.

PACKAGING INFORMATION

Orderable Device	Status ⁽¹⁾	Package Type	Package Drawing	Pins	Package Qty	Eco Plan ⁽²⁾	Lead/Ball Finish	MSL Peak Temp ⁽³⁾
OPA404AG	NRND	CDIP SB	JD	14	1	Green (RoHS & no Sb/Br)	AU	N / A for Pkg Type
OPA404BG	NRND	CDIP SB	JD	14	1	Green (RoHS & no Sb/Br)	AU	N / A for Pkg Type
OPA404KP	ACTIVE	PDIP	N	14	25	Green (RoHS & no Sb/Br)	CU NIPDAU	N / A for Pkg Type
OPA404KPG4	ACTIVE	PDIP	N	14	25	Green (RoHS & no Sb/Br)	CU NIPDAU	N / A for Pkg Type
OPA404KU	ACTIVE	SOIC	DW	16	40	Green (RoHS & no Sb/Br)	CU NIPDAU	Level-3-260C-168 HR
OPA404KU/1K	ACTIVE	SOIC	DW	16	1000	Green (RoHS & no Sb/Br)	CU NIPDAU	Level-3-260C-168 HR
OPA404KU/1KE4	ACTIVE	SOIC	DW	16	1000	Green (RoHS & no Sb/Br)	CU NIPDAU	Level-3-260C-168 HR
OPA404KUG4	ACTIVE	SOIC	DW	16	40	Green (RoHS & no Sb/Br)	CU NIPDAU	Level-3-260C-168 HR
OPA404SG	NRND	CDIP SB	JD	14	1	Green (RoHS & no Sb/Br)	AU	N / A for Pkg Type

⁽¹⁾ The marketing status values are defined as follows:

ACTIVE: Product device recommended for new designs.

LIFEBUY: TI has announced that the device will be discontinued, and a lifetime-buy period is in effect.

NRND: Not recommended for new designs. Device is in production to support existing customers, but TI does not recommend using this part in a new design.

PREVIEW: Device has been announced but is not in production. Samples may or may not be available.

OBSELETE: TI has discontinued the production of the device.

⁽²⁾ Eco Plan - The planned eco-friendly classification: Pb-Free (RoHS), Pb-Free (RoHS Exempt), or Green (RoHS & no Sb/Br) - please check <http://www.ti.com/productcontent> for the latest availability information and additional product content details.

TBD: The Pb-Free/Green conversion plan has not been defined.

Pb-Free (RoHS): TI's terms "Lead-Free" or "Pb-Free" mean semiconductor products that are compatible with the current RoHS requirements for all 6 substances, including the requirement that lead not exceed 0.1% by weight in homogeneous materials. Where designed to be soldered at high temperatures, TI Pb-Free products are suitable for use in specified lead-free processes.

Pb-Free (RoHS Exempt): This component has a RoHS exemption for either 1) lead-based flip-chip solder bumps used between the die and package, or 2) lead-based die adhesive used between the die and leadframe. The component is otherwise considered Pb-Free (RoHS compatible) as defined above.

Green (RoHS & no Sb/Br): TI defines "Green" to mean Pb-Free (RoHS compatible), and free of Bromine (Br) and Antimony (Sb) based flame retardants (Br or Sb do not exceed 0.1% by weight in homogeneous material)

⁽³⁾ MSL, Peak Temp. -- The Moisture Sensitivity Level rating according to the JEDEC industry standard classifications, and peak solder temperature.

Important Information and Disclaimer:The information provided on this page represents TI's knowledge and belief as of the date that it is provided. TI bases its knowledge and belief on information provided by third parties, and makes no representation or warranty as to the accuracy of such information. Efforts are underway to better integrate information from third parties. TI has taken and continues to take reasonable steps to provide representative and accurate information but may not have conducted destructive testing or chemical analysis on incoming materials and chemicals. TI and TI suppliers consider certain information to be proprietary, and thus CAS numbers and other limited information may not be available for release.

In no event shall TI's liability arising out of such information exceed the total purchase price of the TI part(s) at issue in this document sold by TI to Customer on an annual basis.

TAPE AND REEL INFORMATION

REEL DIMENSIONS

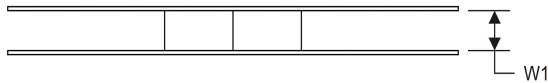
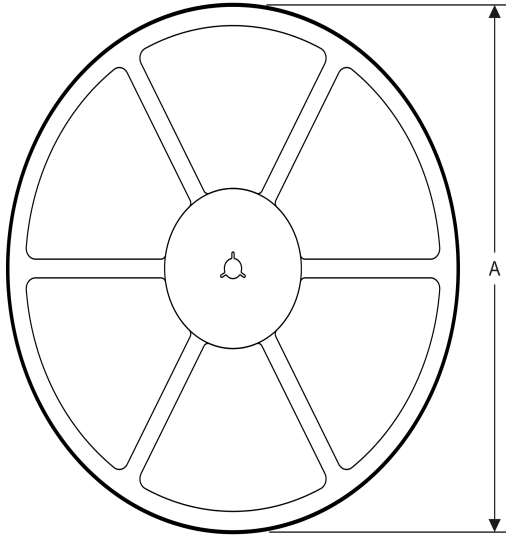

TAPE DIMENSIONS

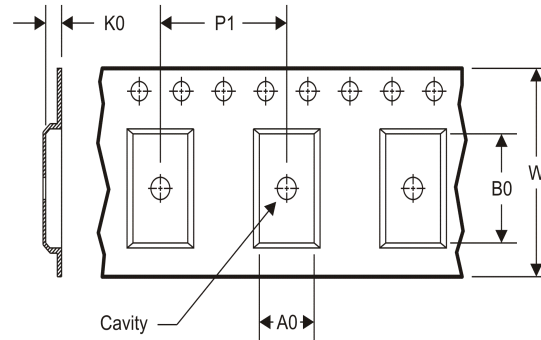

A0	Dimension designed to accommodate the component width
B0	Dimension designed to accommodate the component length
K0	Dimension designed to accommodate the component thickness
W	Overall width of the carrier tape
P1	Pitch between successive cavity centers

TAPE AND REEL INFORMATION

*All dimensions are nominal

Device	Package Type	Package Drawing	Pins	SPQ	Reel Diameter (mm)	Reel Width W1 (mm)	A0 (mm)	B0 (mm)	K0 (mm)	P1 (mm)	W (mm)	Pin1 Quadrant
OPA404KU/1K	SOIC	DW	16	1000	330.0	16.4	10.75	10.7	2.7	12.0	16.0	Q1

TAPE AND REEL BOX DIMENSIONS

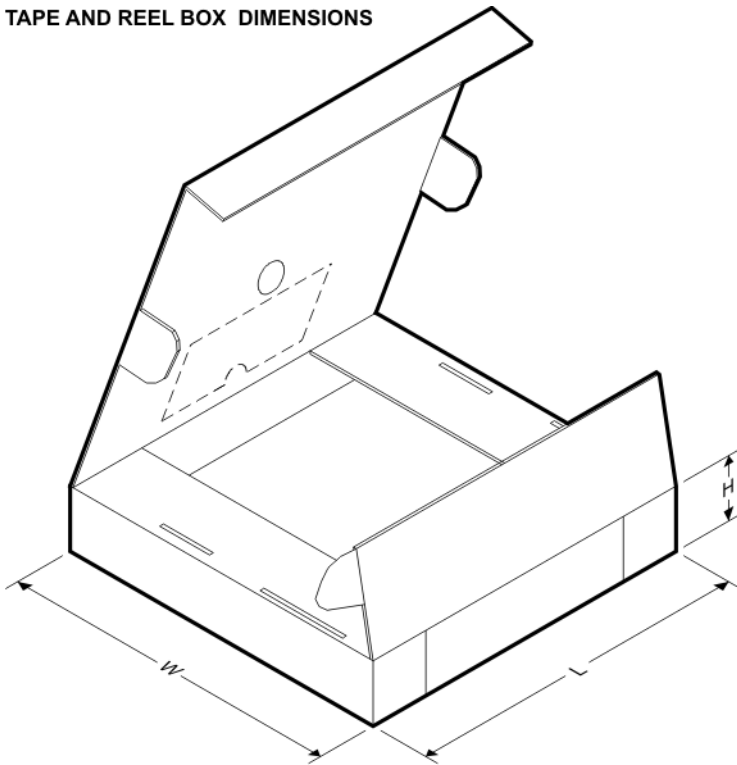

*All dimensions are nominal

Device	Package Type	Package Drawing	Pins	SPQ	Length (mm)	Width (mm)	Height (mm)
OPA404KU/1K	SOIC	DW	16	1000	367.0	367.0	38.0

IMPORTANT NOTICE

Texas Instruments Incorporated and its subsidiaries (TI) reserve the right to make corrections, enhancements, improvements and other changes to its semiconductor products and services per JESD46C and to discontinue any product or service per JESD48B. Buyers should obtain the latest relevant information before placing orders and should verify that such information is current and complete. All semiconductor products (also referred to herein as "components") are sold subject to TI's terms and conditions of sale supplied at the time of order acknowledgment.

TI warrants performance of its components to the specifications applicable at the time of sale, in accordance with the warranty in TI's terms and conditions of sale of semiconductor products. Testing and other quality control techniques are used to the extent TI deems necessary to support this warranty. Except where mandated by applicable law, testing of all parameters of each component is not necessarily performed.

TI assumes no liability for applications assistance or the design of Buyers' products. Buyers are responsible for their products and applications using TI components. To minimize the risks associated with Buyers' products and applications, Buyers should provide adequate design and operating safeguards.

TI does not warrant or represent that any license, either express or implied, is granted under any patent right, copyright, mask work right, or other intellectual property right relating to any combination, machine, or process in which TI components or services are used. Information published by TI regarding third-party products or services does not constitute a license to use such products or services or a warranty or endorsement thereof. Use of such information may require a license from a third party under the patents or other intellectual property of the third party, or a license from TI under the patents or other intellectual property of TI.

Reproduction of significant portions of TI information in TI data books or data sheets is permissible only if reproduction is without alteration and is accompanied by all associated warranties, conditions, limitations, and notices. TI is not responsible or liable for such altered documentation. Information of third parties may be subject to additional restrictions.

Resale of TI components or services with statements different from or beyond the parameters stated by TI for that component or service voids all express and any implied warranties for the associated TI component or service and is an unfair and deceptive business practice. TI is not responsible or liable for any such statements.

Buyer acknowledges and agrees that it is solely responsible for compliance with all legal, regulatory and safety-related requirements concerning its products, and any use of TI components in its applications, notwithstanding any applications-related information or support that may be provided by TI. Buyer represents and agrees that it has all the necessary expertise to create and implement safeguards which anticipate dangerous consequences of failures, monitor failures and their consequences, lessen the likelihood of failures that might cause harm and take appropriate remedial actions. Buyer will fully indemnify TI and its representatives against any damages arising out of the use of any TI components in safety-critical applications.

In some cases, TI components may be promoted specifically to facilitate safety-related applications. With such components, TI's goal is to help enable customers to design and create their own end-product solutions that meet applicable functional safety standards and requirements. Nonetheless, such components are subject to these terms.

No TI components are authorized for use in FDA Class III (or similar life-critical medical equipment) unless authorized officers of the parties have executed a special agreement specifically governing such use.

Only those TI components which TI has specifically designated as military grade or "enhanced plastic" are designed and intended for use in military/aerospace applications or environments. Buyer acknowledges and agrees that any military or aerospace use of TI components which have **not** been so designated is solely at the Buyer's risk, and that Buyer is solely responsible for compliance with all legal and regulatory requirements in connection with such use.

TI has specifically designated certain components which meet ISO/TS16949 requirements, mainly for automotive use. Components which have not been so designated are neither designed nor intended for automotive use; and TI will not be responsible for any failure of such components to meet such requirements.

Products

Audio	www.ti.com/audio
Amplifiers	amplifier.ti.com
Data Converters	dataconverter.ti.com
DLP® Products	www.dlp.com
DSP	dsp.ti.com
Clocks and Timers	www.ti.com/clocks
Interface	interface.ti.com
Logic	logic.ti.com
Power Mgmt	power.ti.com
Microcontrollers	microcontroller.ti.com
RFID	www.ti-rfid.com
OMAP Mobile Processors	www.ti.com/omap
Wireless Connectivity	www.ti.com/wirelessconnectivity

Applications

Automotive and Transportation	www.ti.com/automotive
Communications and Telecom	www.ti.com/communications
Computers and Peripherals	www.ti.com/computers
Consumer Electronics	www.ti.com/consumer-apps
Energy and Lighting	www.ti.com/energy
Industrial	www.ti.com/industrial
Medical	www.ti.com/medical
Security	www.ti.com/security
Space, Avionics and Defense	www.ti.com/space-avionics-defense
Video and Imaging	www.ti.com/video

TI E2E Community e2e.ti.com