

OPA128

Difet[®] Electrometer-Grade OPERATIONAL AMPLIFIER

FEATURES

- ULTRA-LOW BIAS CURRENT: 75fA max
- LOW OFFSET: 500 μ V max
- LOW DRIFT: 5 μ V/ $^{\circ}$ C max
- HIGH OPEN-LOOP GAIN: 110dB min
- HIGH COMMON-MODE REJECTION: 90dB min
- IMPROVED REPLACEMENT FOR AD515 AND AD549

APPLICATIONS

- ELECTROMETER
- MASS SPECTROMETER
- CHROMATOGRAPH
- ION GAUGE
- PHOTODETECTOR
- RADIATION-HARD EQUIPMENT

DESCRIPTION

The OPA128 is an ultra-low bias current monolithic operational amplifier. Using advanced geometry dielectrically-isolated FET (*Difet*[®]) inputs, this monolithic amplifier achieves a performance level exceeding even the best hybrid electrometer amplifiers.

Laser-trimmed thin-film resistors give outstanding voltage offset and drift performance.

A noise-free cascode and low-noise processing give the OPA128 excellent low-level signal handling capabilities. Flicker noise is very low.

The OPA128 is an improved pin-for-pin replacement for the AD515.

Difet[®] Burr-Brown Corp.

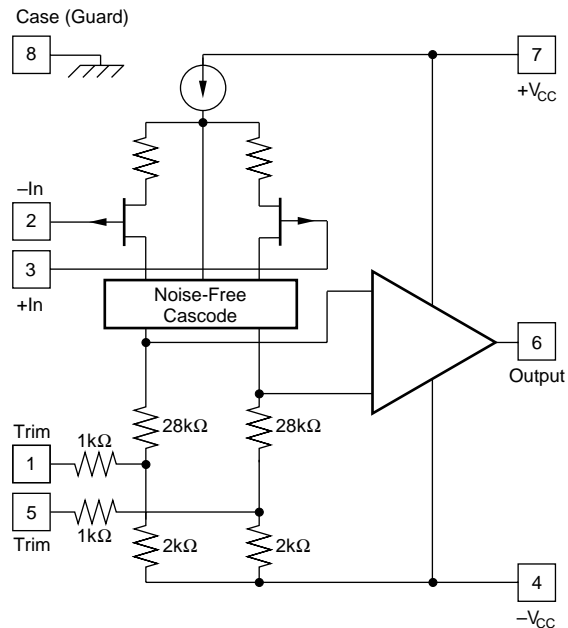

OPA128 Simplified Circuit

SPECIFICATIONS

ELECTRICAL

At $V_{CC} = \pm 15\text{VDC}$ and $T_A = +25^\circ\text{C}$, unless otherwise noted. Pin 8 connected to ground.

PARAMETER	CONDITIONS	OPA128JM			OPA128KM			OPA128LM			OPA128SM			UNITS
		MIN	TYP	MAX	MIN	TYP	MAX	MIN	TYP	MAX	MIN	TYP	MAX	
INPUT														
BIAS CURRENT⁽¹⁾ Input Bias Current	$V_{CM} = 0\text{VDC}$, $R_L \geq 10\text{k}\Omega$		± 150	± 300		± 75	± 150		± 40	± 75		± 75	± 150	fA
OFFSET CURRENT⁽¹⁾ Input Offset Current	$V_{CM} = 0\text{VDC}$, $R_L \geq 10\text{k}\Omega$		65			30			30			30		fA
OFFSET VOLTAGE⁽¹⁾ Input Offset Voltage Average Drift Supply Rejection	$V_{CM} = 0\text{VDC}$ $T_A = T_{MIN}$ to T_{MAX}	80	± 260 120 ± 1	± 1000 ± 20 ± 100	90	± 140 120 ± 1	± 500 ± 10 ± 32	90	± 140 120 ± 1	± 500 ± 5 ± 32	90	± 140 120 ± 1	± 500 ± 10 ± 32	μV $\mu\text{V}/^\circ\text{C}$ dB $\mu\text{V}/\text{V}$
NOISE Voltage: $f_O = 10\text{Hz}$ $f_O = 100\text{Hz}$ $f_O = 1\text{kHz}$ $f_O = 10\text{kHz}$ $f_B = 10\text{Hz}$ to 10kHz $f_B = 0.1\text{Hz}$ to 10Hz Current: $f_B = 0.1\text{Hz}$ to 10Hz $f_O = 0.1\text{Hz}$ to 20kHz			92 78 27 15 2.4 4 4.2 0.22			92 78 27 15 2.4 4 3 0.16			92 78 27 15 2.4 4 2.3 0.12			92 78 27 15 2.4 4 3 0.16	$\text{nV}/\sqrt{\text{Hz}}$ $\text{nV}/\sqrt{\text{Hz}}$ $\text{nV}/\sqrt{\text{Hz}}$ $\text{nV}/\sqrt{\text{Hz}}$ μVrms $\mu\text{Vp-p}$ fA, p-p $\text{fA}/\sqrt{\text{Hz}}$	
IMPEDANCE Differential Common-Mode			$10^{13} \parallel 1$ $10^{15} \parallel 2$			$10^{13} \parallel 1$ $10^{15} \parallel 2$			$10^{13} \parallel 1$ $10^{15} \parallel 2$			$10^{13} \parallel 1$ $10^{15} \parallel 2$		$\Omega \parallel \text{pF}$ $\Omega \parallel \text{pF}$
VOLTAGE RANGE⁽⁴⁾ Common-Mode Input Range Common-Mode Rejection	$V_{IN} = \pm 10\text{VDC}$	± 10 80	± 12 118		± 10 90	± 12 118		± 10 90	± 12 118		± 10 90	± 12 118		V dB
OPEN-LOOP GAIN, DC														
Open-Loop Voltage Gain	$R_L \geq 2\text{k}\Omega$	94	128		110	128		110	128		110	128		dB
FREQUENCY RESPONSE														
Unity Gain, Small Signal Full Power Response Slew Rate Settling Time, 0.1% 0.01% Overload Recovery, 50% Overdrive ⁽³⁾	⁽²⁾ 20Vp-p, $R_L = 2\text{k}\Omega$ $V_O = \pm 10\text{V}$, $R_L = 2\text{k}\Omega$ Gain = -1, $R_L = 2\text{k}\Omega$ 10V Step Gain = -1	0.5 0.5	1 47 3 5 10		0.5 1	1 47 3 5 10		0.5 1	1 47 3 5 10		0.5 1	1 47 3 5 10		MHz kHz V/ μs μs μs μs
RATED OUTPUT														
Voltage Output Current Output Output Resistance Load Capacitance Stability Short Circuit Current	$R_L = 2\text{k}\Omega$ $V_O = \pm 10\text{VDC}$ DC, Open Loop Gain = +1	± 10 ± 5	± 13 ± 10 100 1000		± 10 ± 5	± 13 ± 10 100 1000		± 10 ± 5	± 13 ± 10 100 1000		± 10 ± 5	± 13 ± 10 100 1000		V mA Ω pF mA
POWER SUPPLY														
Rated Voltage Voltage Range, Derated Performance Current, Quiescent			± 15 ± 5		± 15 ± 5		± 15 ± 5		± 15 ± 5		± 15 ± 5		± 15 ± 5	VDC VDC mA
TEMPERATURE RANGE														
Specification Operating Storage θ Junction-Ambient	Ambient Temp. Ambient Temp. Ambient Temp.	0 -55 -65		+70 +125 +150	0 -55 -65		+70 +125 +150	0 -55 -65		+70 +125 +150	-55 -55 -65		+125 +125 +150	$^\circ\text{C}$ $^\circ\text{C}$ $^\circ\text{C}$ $^\circ\text{C}/\text{W}$

NOTES: (1) Offset voltage, offset current, and bias current are measured with the units fully warmed up. Bias current doubles approximately every 11°C . (2) Small signal tested. (3) Overload recovery is defined as the time required for the output to return from saturation to linear operation following the removal of a 50% input overdrive. (4) If it is possible for the input voltage to exceed the supply voltage, a series protection resistor should be added to limit input current to 0.5mA. The input devices can withstand overload currents of 0.3mA indefinitely without damage.

The information provided herein is believed to be reliable; however, BURR-BROWN assumes no responsibility for inaccuracies or omissions. BURR-BROWN assumes no responsibility for the use of this information, and all use of such information shall be entirely at the user's own risk. Prices and specifications are subject to change without notice. No patent rights or licenses to any of the circuits described herein are implied or granted to any third party. BURR-BROWN does not authorize or warrant any BURR-BROWN product for use in life support devices and/or systems.

ELECTRICAL (FULL TEMPERATURE RANGE SPECIFICATIONS)

At $V_{CC} = \pm 15\text{VDC}$ and $T_A = T_{MIN}$ and T_{MAX} , unless otherwise noted.

PARAMETER	CONDITIONS	OPA128JM			OPA128KM			OPA128LM			OPA128SM			UNITS
		MIN	TYP	MAX	MIN	TYP	MAX	MIN	TYP	MAX	MIN	TYP	MAX	
TEMPERATURE RANGE														
Specification Range	Ambient Temp.	0		+70	0		+70	0		+70	-55		+125	°C
INPUT														
BIAS CURRENT⁽¹⁾ Input Bias Current	$V_{CM} = 0\text{VDC}$		± 2.5	± 8		± 1.3	± 4		± 0.7	± 2		± 43	± 170	pA
OFFSET CURRENT⁽¹⁾ Input Offset Current	$V_{CM} = 0\text{VDC}$		1.1			0.6			0.6			18		pA
OFFSET VOLTAGE⁽¹⁾ Input Offset Voltage Average Drift Supply Rejection	$V_{CM} = 0\text{VDC}$			$\pm 2.2\text{mV}$ ± 20			$\pm 1\text{mV}$ ± 10			± 750 ± 5			$\pm 1.5\text{mV}$ ± 10	μV $\mu\text{V}/^\circ\text{C}$ dB $\mu\text{V/V}$
VOLTAGE RANGE⁽²⁾ Common-Mode Input Range Common-Mode Rejection	$V_{IN} = \pm 10\text{VDC}$	± 10 74	± 11 114 ± 2		± 10 80	± 11 114 ± 2		± 10 80	± 11 114 ± 2		± 10 74	± 11 104		V dB
OPEN-LOOP GAIN, DC														
Open-Loop Voltage Gain	$R_L \geq 2\text{k}\Omega$	90	125		104	125		104	125		90	122		dB
RATED OUTPUT														
Voltage Output Current Output Short Circuit Current	$R_L = 2\text{k}\Omega$ $V_O = \pm 10\text{VDC}$ $V_O = 0\text{VDC}$	± 10 ± 5 10			± 10 ± 5 10			± 10 ± 5 10			± 10 ± 5 10			V mA mA
POWER SUPPLY														
Current, Quiescent	$I = 0\text{mADC}$		0.9	1.8		0.9	1.8		0.9	1.8		0.9	2	mA

NOTES: (1) Offset voltage, offset current, and bias current are measured with the units fully warmed up. (2) If it is possible for the input voltage to exceed the supply voltage, a series protection resistor should be added to limit input current to 0.5mA. The input devices can withstand overload currents of 0.3mA indefinitely without damage.

CONNECTION DIAGRAM

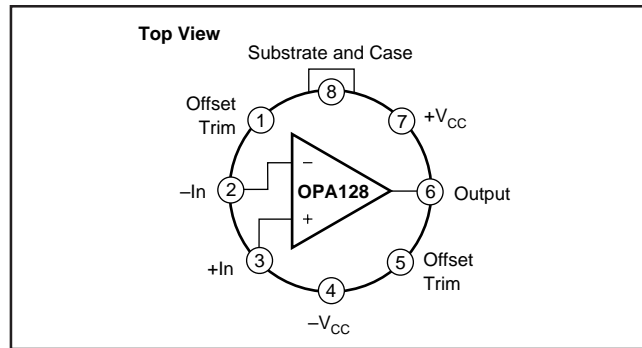

ABSOLUTE MAXIMUM RATINGS

Supply	$\pm 18\text{VDC}$
Internal Power Dissipation ⁽¹⁾	500mW
Differential Input Voltage	$\pm 36\text{VDC}$
Input Voltage Range	$\pm 18\text{VDC}$
Storage Temperature Range	-65°C to $+150^\circ\text{C}$
Operating Temperature Range	-55°C to $+125^\circ\text{C}$
Lead Temperature (soldering, 10s)	$+300^\circ\text{C}$
Output Short Circuit Duration ⁽²⁾	Continuous
Junction Temperature	$+175^\circ\text{C}$

NOTES: (1) Packages must be derated based on $\theta_{CA} = 150^\circ\text{C/W}$ or $\theta_{JA} = 200^\circ\text{C/W}$. (2) Short circuit may be to power supply common only. Rating applies to $+25^\circ\text{C}$ ambient. Observe dissipation limit and T_J .

ORDERING INFORMATION

PRODUCT	PACKAGE	TEMPERATURE RANGE	BIAS CURRENT, max (fA)
OPA128JM	TO-99	0°C to $+70^\circ\text{C}$	± 300
OPA128KM	TO-99	0°C to $+70^\circ\text{C}$	± 150
OPA128LM	TO-99	0°C to $+70^\circ\text{C}$	± 75
OPA128SM	TO-99	-55°C to $+125^\circ\text{C}$	± 150

PACKAGE INFORMATION

PRODUCT	PACKAGE	PACKAGE DRAWING NUMBER ⁽¹⁾
OPA128JM	TO-99	001
OPA128KM	TO-99	001
OPA128LM	TO-99	001
OPA128SM	TO-99	001

NOTE: (1) For detailed drawing and dimension table, please see end of data sheet, or Appendix C of Burr-Brown IC Data Book.

DICE INFORMATION

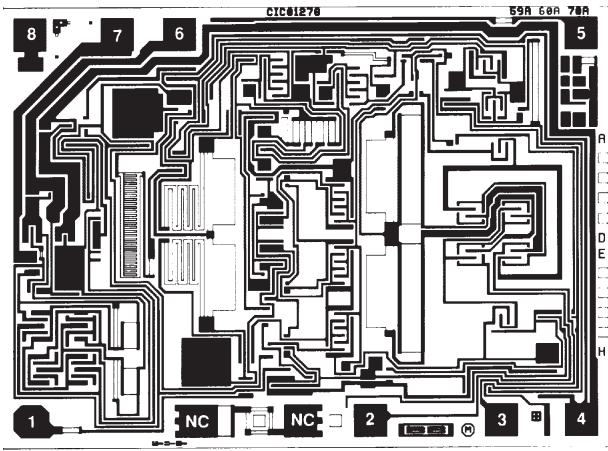

OPA128 DIE TOPOGRAPHY

PAD	FUNCTION
1	Offset Trim
2	-In
3	+In
4	-V _{CC}
5	Offset Trim
6	Output
7	+V _{CC}
8	Substrate
NC	No Connection

Substrate Bias: Isolated, normally connected to common.

MECHANICAL INFORMATION

	MILS (0.001")	MILLIMETERS
Die Size	96 x 71 ±5	2.44 x 1.80 ±0.13
Die Thickness	20 ±3	0.51 ±0.08
Min. Pad Size	4 x 4	0.10 x 0.10
Backing	None	

TYPICAL PERFORMANCE CURVES

At T_A = +25°C, ±15VDC, unless otherwise noted.

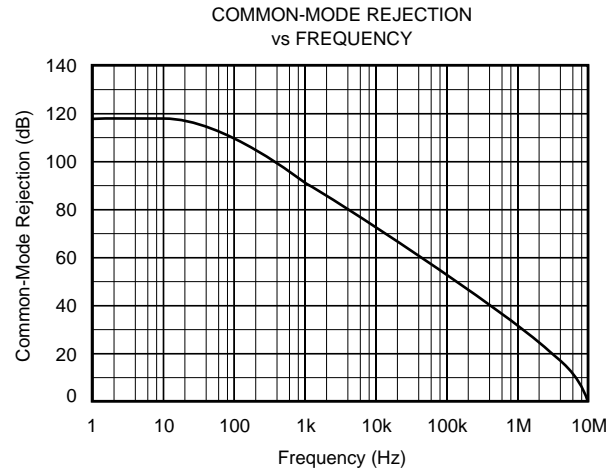
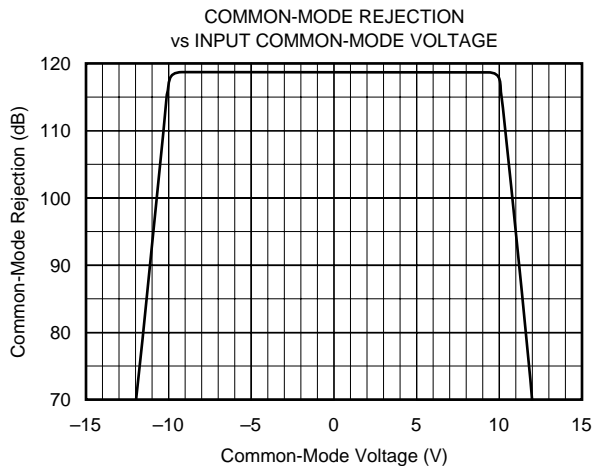
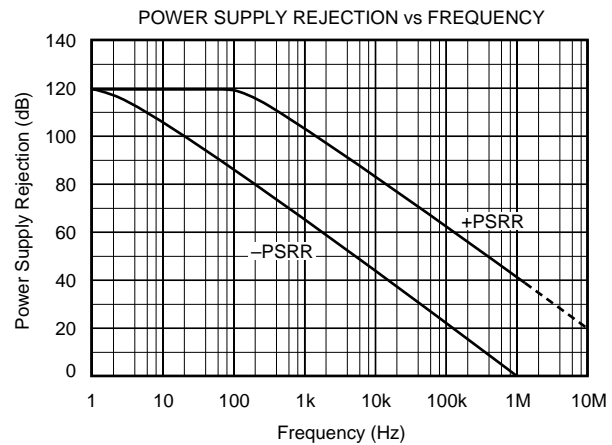
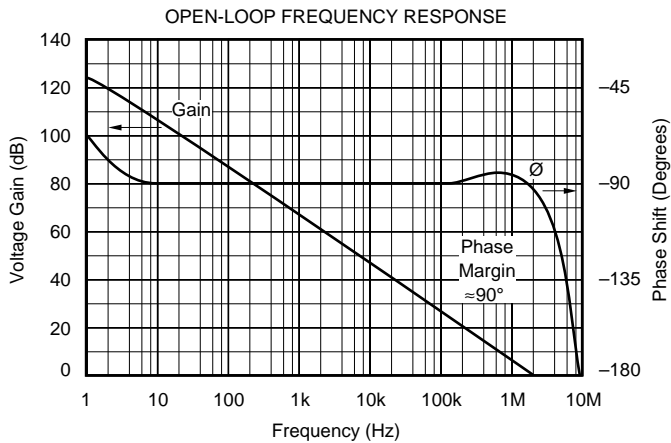

TYPICAL PERFORMANCE CURVES (CONT)

At $T_A = +25^\circ\text{C}$, $+15\text{VDC}$, unless otherwise noted.

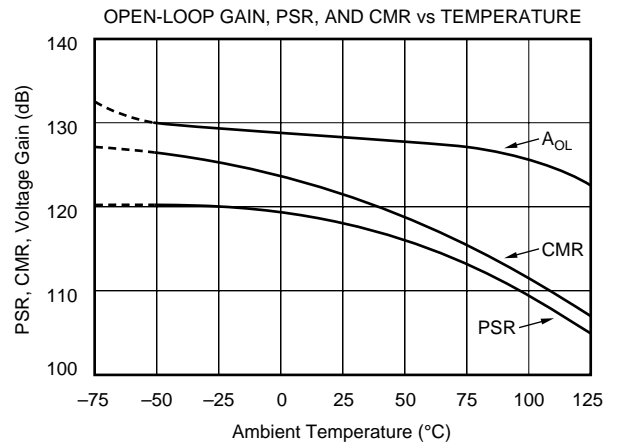
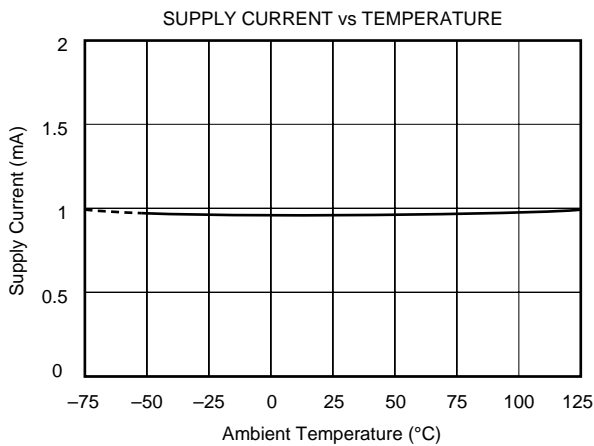
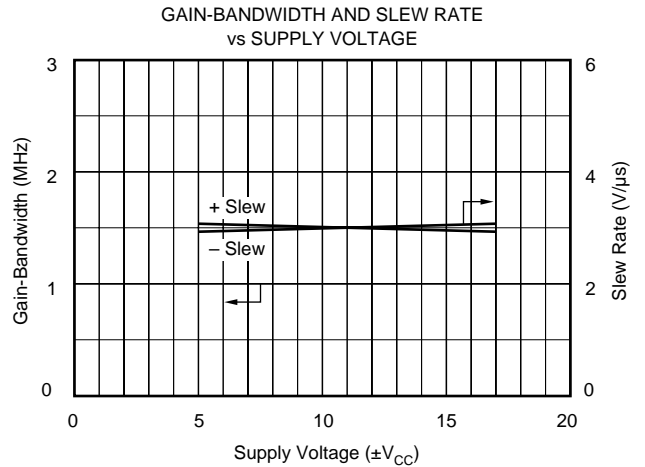
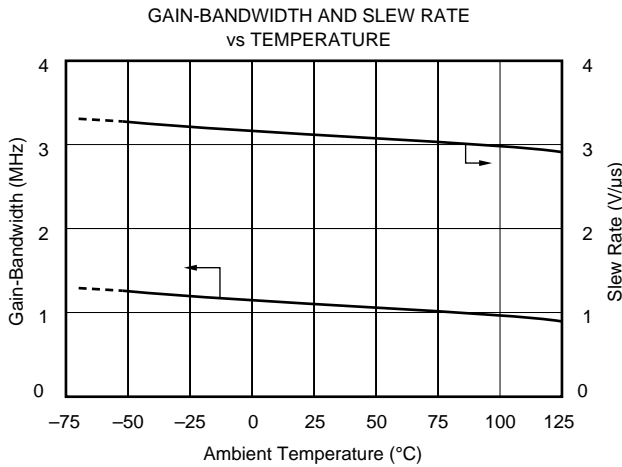
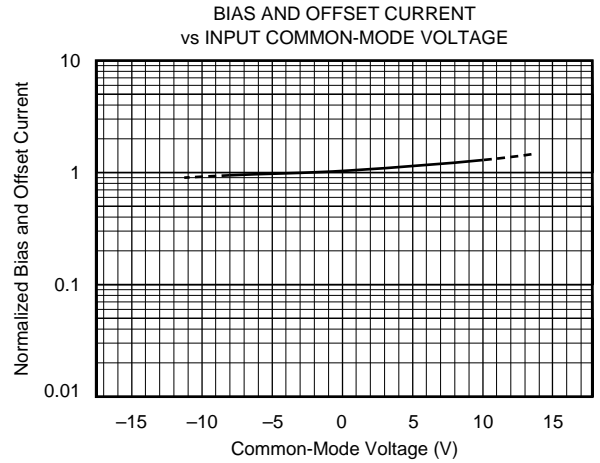
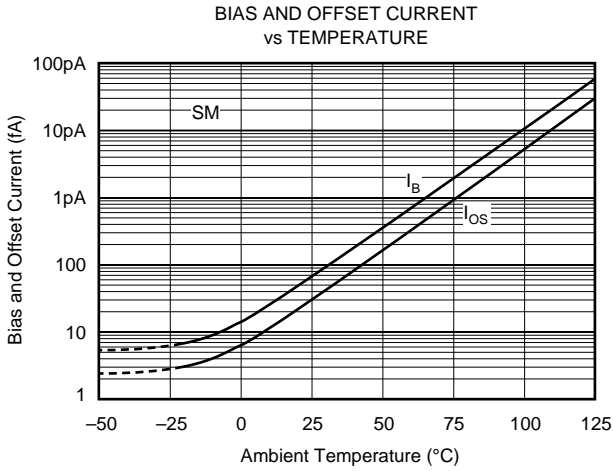

TYPICAL PERFORMANCE CURVES (CONT)

At $T_A = +25^\circ\text{C}$, $+15\text{VDC}$, unless otherwise noted.

LARGE SIGNAL TRANSIENT RESPONSE

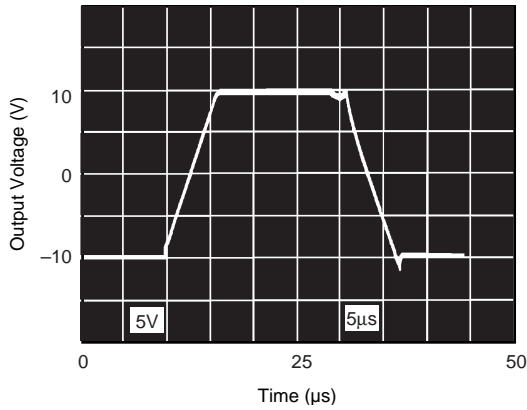

SMALL SIGNAL TRANSIENT RESPONSE

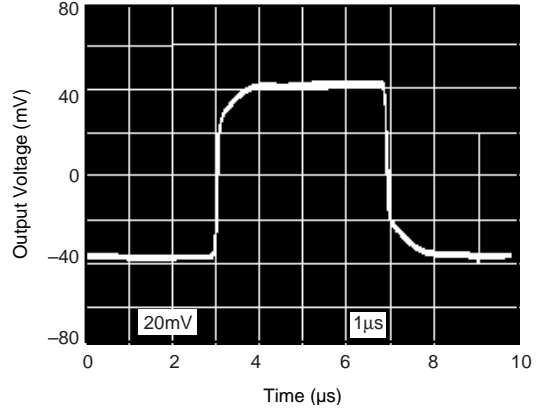

COMMON-MODE INPUT RANGE vs SUPPLY VOLTAGE

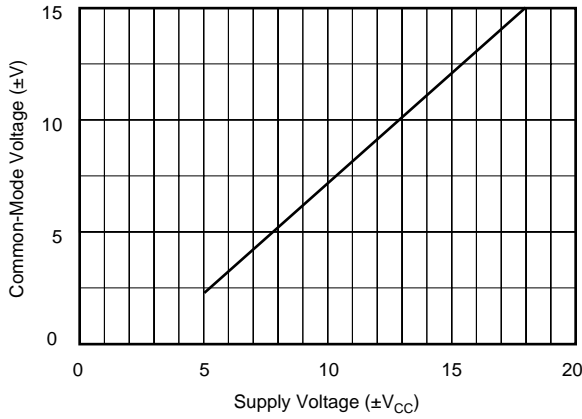

BIAS CURRENT vs ADDITIONAL POWER DISSIPATION

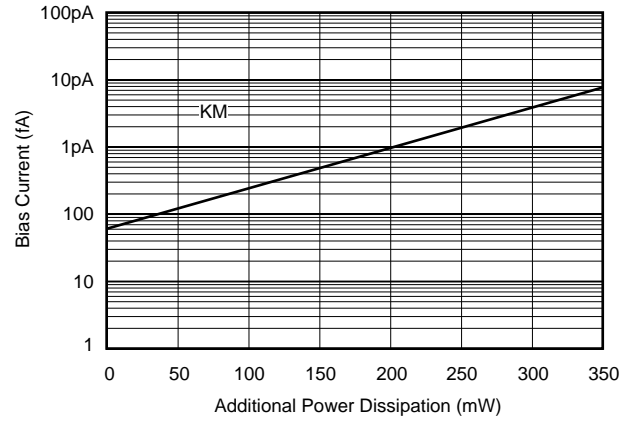

INPUT VOLTAGE NOISE SPECTRAL DENSITY

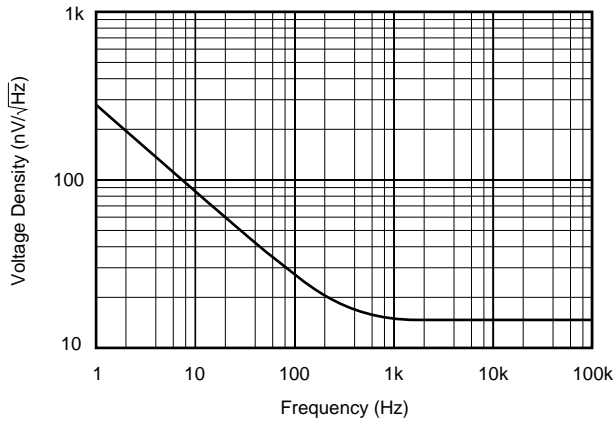

FULL-POWER OUTPUT vs FREQUENCY

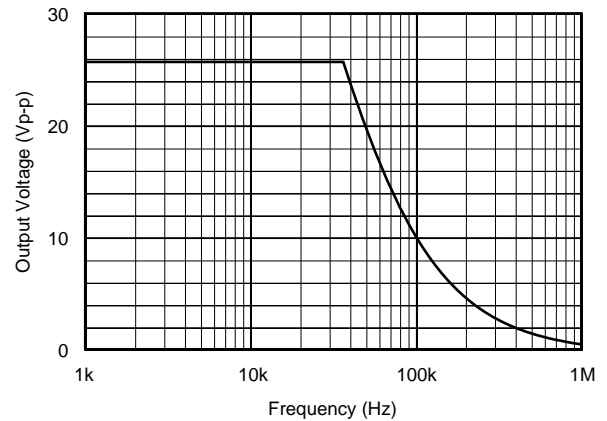

APPLICATIONS INFORMATION

OFFSET VOLTAGE ADJUSTMENT

The OPA128 offset voltage is laser-trimmed and will require no further trim for most applications. As with most amplifiers, externally trimming the remaining offset can change drift performance by about $0.3\mu\text{V}/^\circ\text{C}$ for each $100\mu\text{V}$ of adjusted effort. Note that the trim (Figure 1) is similar to operational amplifiers such as HA-5180 and AD515. The OPA128 can replace many other amplifiers by leaving the external null circuit unconnected.

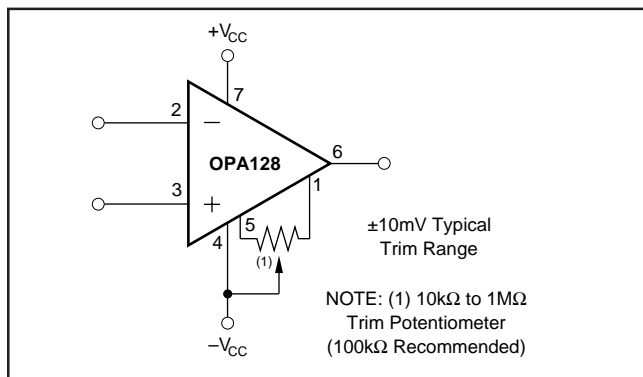

FIGURE 1. Offset Voltage Trim.

INPUT PROTECTION

Conventional monolithic FET operational amplifiers' inputs must be protected against destructive currents that can flow when input FET gate-to-substrate isolation diodes are forward-biased. Most BIFET® amplifiers can be destroyed by the loss of $-V_{CC}$.

Because of its dielectric isolation, no special protection is needed on the OPA128. Of course, the differential and common-mode voltage limits should be observed.

Static damage can cause subtle changes in amplifier input characteristics without necessarily destroying the device. In precision operational amplifiers (both bipolar and FET types), this may cause a noticeable degradation of offset voltage and drift.

Static protection is recommended when handling any precision IC operational amplifier.

GUARDING AND SHIELDING

As in any situation where high impedances are involved, careful shielding is required to reduce "hum" pickup in input leads. If large feedback resistors are used, they should also be shielded along with the external input circuitry. Leakage currents across printed circuit boards can easily exceed the bias current of the OPA128. To avoid leakage problems, it is recommended that the signal input lead of the OPA128 be wired to a Teflon standoff. If the input is to be soldered directly into a printed circuit board, utmost care must be used in planning the board layout. A "guard" pattern should completely surround the high impedance input leads and should be connected to a low impedance point which is at the signal input potential.

The amplifier case should be connected to any input shield or guard via pin 8. This insures that the amplifier itself is fully surrounded by guard potential, minimizing both leakage and noise pickup (see Figure 2).

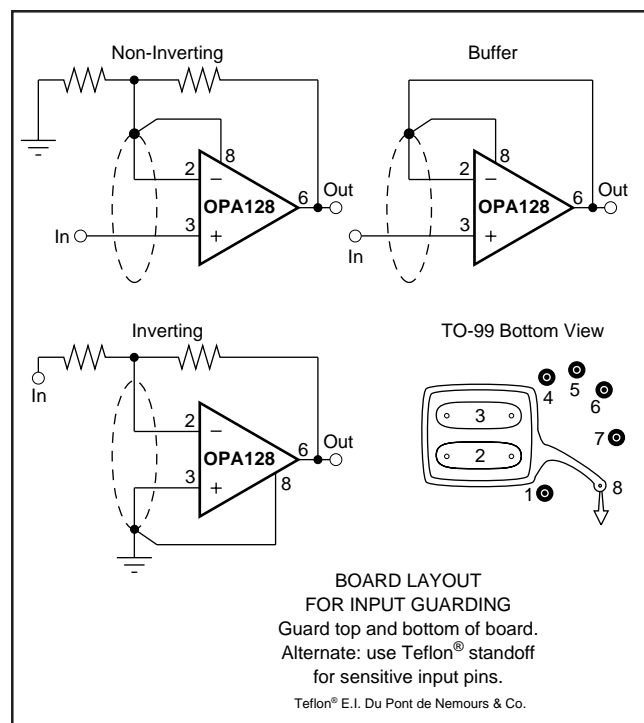

FIGURE 2. Connection of Input Guard.

Triboelectric charge (static electricity generated by friction) can be a troublesome noise source from cables connected to the input of an electrometer amplifier. Special low-noise cable will minimize this effect but the optimum solution is to mount the signal source directly at the electrometer input with short, rigid, wiring to preclude microphonic noise generation.

TESTING

Accurately testing the OPA128 is extremely difficult due to its high level of performance. Ordinary test equipment may not be able to resolve the amplifier's extremely low bias current.

Inaccurate bias current measurements can be due to:

1. Test socket leakage
2. Unclean package
3. Humidity or dew point condensation
4. Circuit contamination from fingerprints or anti-static treatment chemicals
5. Test ambient temperature
6. Load power dissipation

BIFET® National Semiconductor Corp.

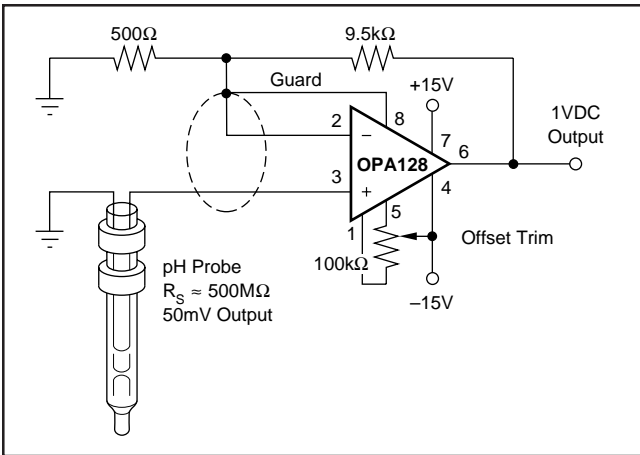

FIGURE 3. High Impedance ($10^{15}\Omega$) Amplifier.

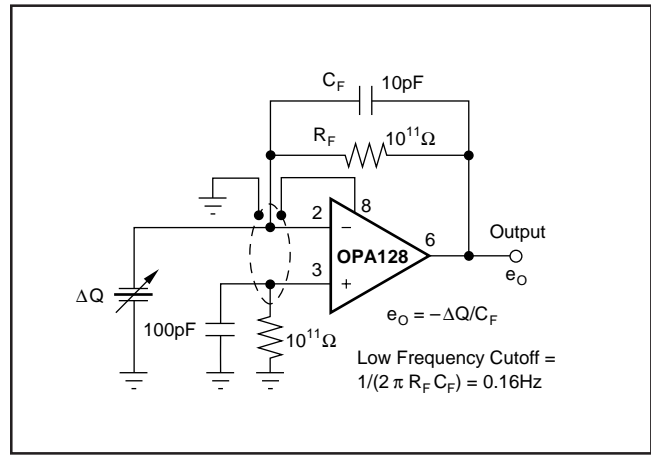

FIGURE 4. Piezoelectric Transducer Charge Amplifier.

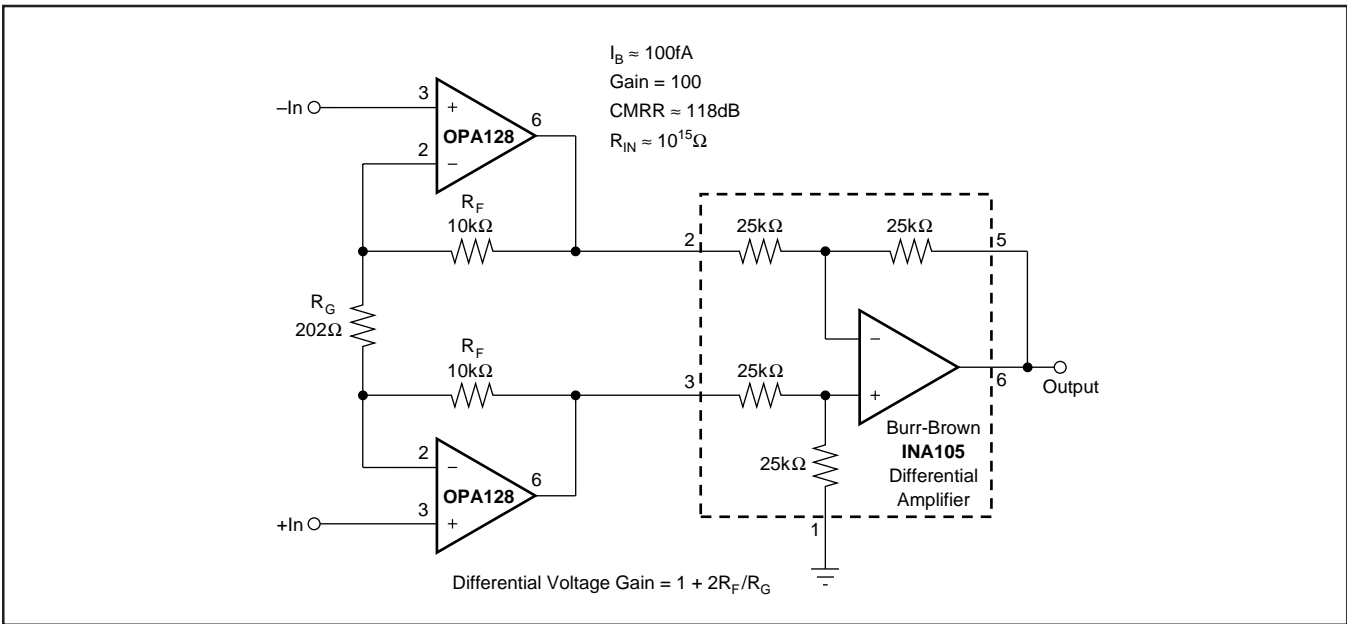

FIGURE 5. FET Input Instrumentation Amplifier for Biomedical Applications.

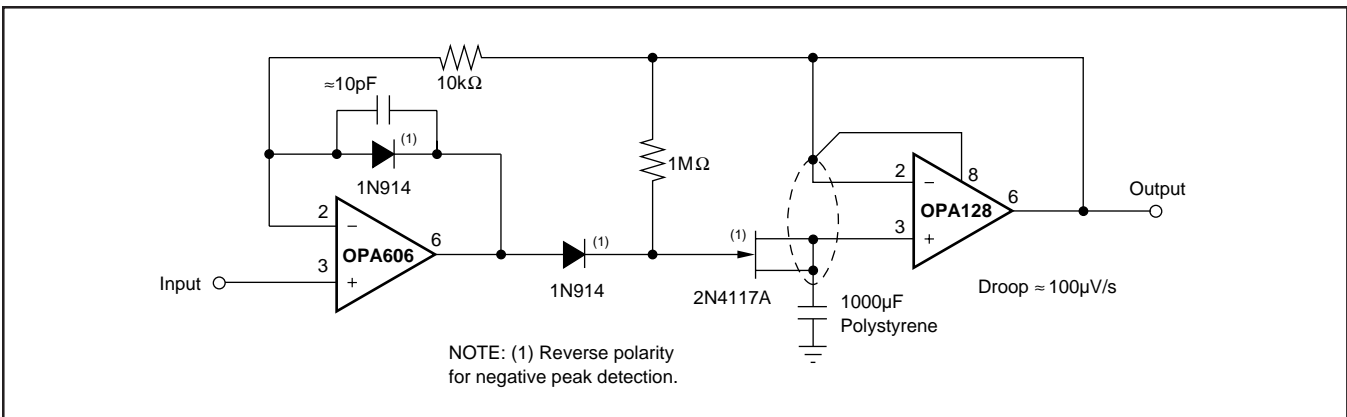

FIGURE 6. Low-Droop Positive Peak Detector.

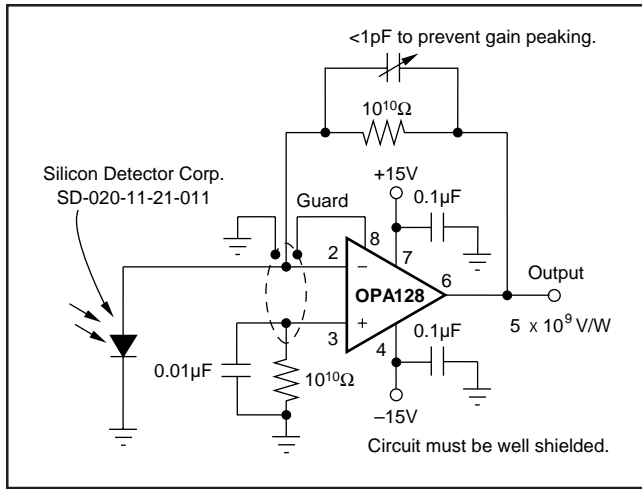

FIGURE 7. Sensitive Photodiode Amplifier.

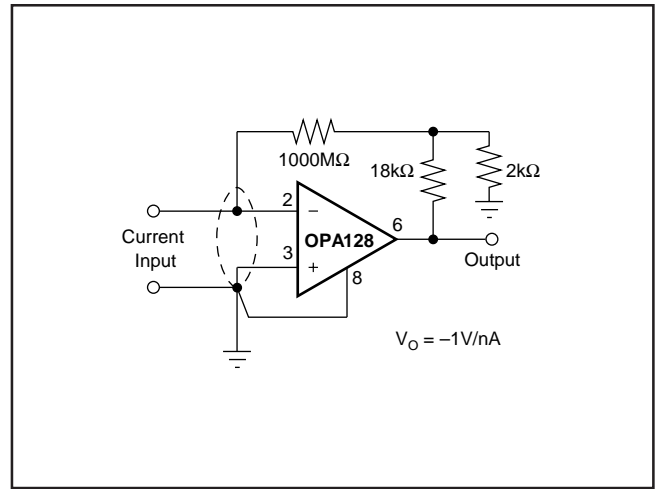

FIGURE 8. Current-to-Voltage Converter.

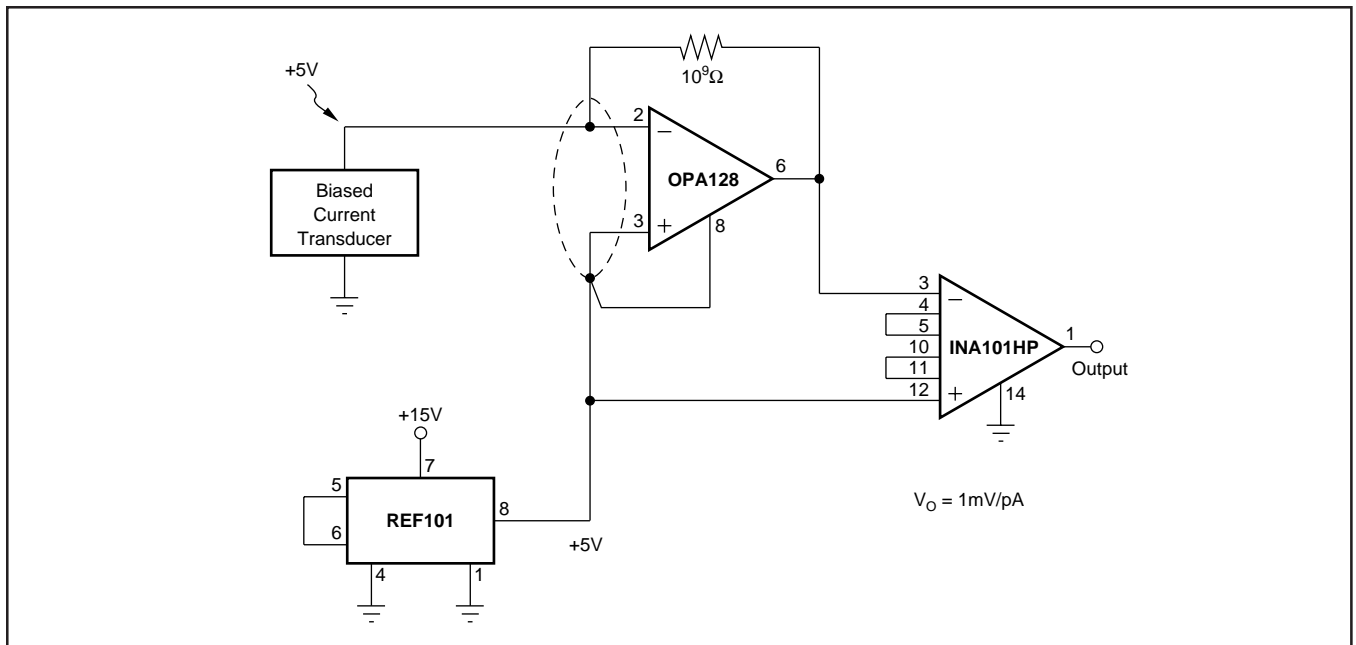

FIGURE 9. Biased Current-to-Voltage Converter.

PACKAGING INFORMATION

Orderable Device	Status ⁽¹⁾	Package Type	Package Drawing	Pins	Package Qty	Eco Plan ⁽²⁾	Lead/Ball Finish	MSL Peak Temp ⁽³⁾
OPA128JM	NRND	TO-99	LMC	8	20	Green (RoHS & no Sb/Br)	Call TI	N / A for Pkg Type
OPA128KM	NRND	TO-99	LMC	8	20	Green (RoHS & no Sb/Br)	Call TI	N / A for Pkg Type
OPA128LM	NRND	TO-99	LMC	8	20	Green (RoHS & no Sb/Br)	Call TI	N / A for Pkg Type
OPA128SM	NRND	TO-99	LMC	8	20	Green (RoHS & no Sb/Br)	Call TI	N / A for Pkg Type

⁽¹⁾ The marketing status values are defined as follows:

ACTIVE: Product device recommended for new designs.

LIFEBUY: TI has announced that the device will be discontinued, and a lifetime-buy period is in effect.

NRND: Not recommended for new designs. Device is in production to support existing customers, but TI does not recommend using this part in a new design.

PREVIEW: Device has been announced but is not in production. Samples may or may not be available.

OBSOLETE: TI has discontinued the production of the device.

⁽²⁾ Eco Plan - The planned eco-friendly classification: Pb-Free (RoHS), Pb-Free (RoHS Exempt), or Green (RoHS & no Sb/Br) - please check <http://www.ti.com/productcontent> for the latest availability information and additional product content details.

TBD: The Pb-Free/Green conversion plan has not been defined.

Pb-Free (RoHS): TI's terms "Lead-Free" or "Pb-Free" mean semiconductor products that are compatible with the current RoHS requirements for all 6 substances, including the requirement that lead not exceed 0.1% by weight in homogeneous materials. Where designed to be soldered at high temperatures, TI Pb-Free products are suitable for use in specified lead-free processes.

Pb-Free (RoHS Exempt): This component has a RoHS exemption for either 1) lead-based flip-chip solder bumps used between the die and package, or 2) lead-based die adhesive used between the die and leadframe. The component is otherwise considered Pb-Free (RoHS compatible) as defined above.

Green (RoHS & no Sb/Br): TI defines "Green" to mean Pb-Free (RoHS compatible), and free of Bromine (Br) and Antimony (Sb) based flame retardants (Br or Sb do not exceed 0.1% by weight in homogeneous material)

⁽³⁾ MSL, Peak Temp. -- The Moisture Sensitivity Level rating according to the JEDEC industry standard classifications, and peak solder temperature.

Important Information and Disclaimer:The information provided on this page represents TI's knowledge and belief as of the date that it is provided. TI bases its knowledge and belief on information provided by third parties, and makes no representation or warranty as to the accuracy of such information. Efforts are underway to better integrate information from third parties. TI has taken and continues to take reasonable steps to provide representative and accurate information but may not have conducted destructive testing or chemical analysis on incoming materials and chemicals. TI and TI suppliers consider certain information to be proprietary, and thus CAS numbers and other limited information may not be available for release.

In no event shall TI's liability arising out of such information exceed the total purchase price of the TI part(s) at issue in this document sold by TI to Customer on an annual basis.

IMPORTANT NOTICE

Texas Instruments Incorporated and its subsidiaries (TI) reserve the right to make corrections, modifications, enhancements, improvements, and other changes to its products and services at any time and to discontinue any product or service without notice. Customers should obtain the latest relevant information before placing orders and should verify that such information is current and complete. All products are sold subject to TI's terms and conditions of sale supplied at the time of order acknowledgment.

TI warrants performance of its hardware products to the specifications applicable at the time of sale in accordance with TI's standard warranty. Testing and other quality control techniques are used to the extent TI deems necessary to support this warranty. Except where mandated by government requirements, testing of all parameters of each product is not necessarily performed.

TI assumes no liability for applications assistance or customer product design. Customers are responsible for their products and applications using TI components. To minimize the risks associated with customer products and applications, customers should provide adequate design and operating safeguards.

TI does not warrant or represent that any license, either express or implied, is granted under any TI patent right, copyright, mask work right, or other TI intellectual property right relating to any combination, machine, or process in which TI products or services are used. Information published by TI regarding third-party products or services does not constitute a license from TI to use such products or services or a warranty or endorsement thereof. Use of such information may require a license from a third party under the patents or other intellectual property of the third party, or a license from TI under the patents or other intellectual property of TI.

Reproduction of information in TI data books or data sheets is permissible only if reproduction is without alteration and is accompanied by all associated warranties, conditions, limitations, and notices. Reproduction of this information with alteration is an unfair and deceptive business practice. TI is not responsible or liable for such altered documentation.

Resale of TI products or services with statements different from or beyond the parameters stated by TI for that product or service voids all express and any implied warranties for the associated TI product or service and is an unfair and deceptive business practice. TI is not responsible or liable for any such statements.

Following are URLs where you can obtain information on other Texas Instruments products and application solutions:

Products		Applications	
Amplifiers	amplifier.ti.com	Audio	www.ti.com/audio
Data Converters	dataconverter.ti.com	Automotive	www.ti.com/automotive
DSP	dsp.ti.com	Broadband	www.ti.com/broadband
Interface	interface.ti.com	Digital Control	www.ti.com/digitalcontrol
Logic	logic.ti.com	Military	www.ti.com/military
Power Mgmt	power.ti.com	Optical Networking	www.ti.com/opticalnetwork
Microcontrollers	microcontroller.ti.com	Security	www.ti.com/security
Low Power Wireless	www.ti.com/lpw	Telephony	www.ti.com/telephony
		Video & Imaging	www.ti.com/video
		Wireless	www.ti.com/wireless

Mailing Address: Texas Instruments
Post Office Box 655303 Dallas, Texas 75265