

LM150/LM350A/LM350 3-Amp Adjustable Regulators

Check for Samples: [LM150](#), [LM350-N](#), [LM350A](#)

FEATURES

- Adjustable output down to 1.2V
- Guaranteed 3A output current
- Guaranteed thermal regulation
- Output is short circuit protected
- Current limit constant with temperature
- P⁺ Product Enhancement tested
- 86 dB ripple rejection
- Guaranteed 1% output voltage tolerance (LM350A)
- Guaranteed max. 0.01%/V line regulation

(LM350A)

- Guaranteed max. 0.3% load regulation (LM350A)

APPLICATIONS

- Adjustable power supplies
- Constant current regulators
- Battery chargers

DESCRIPTION

The LM150 series of adjustable 3-terminal positive voltage regulators is capable of supplying in excess of 3A over a 1.2V to 33V output range. They are exceptionally easy to use and require only 2 external resistors to set the output voltage. Further, both line and load regulation are comparable to discrete designs. Also, the LM150 is packaged in standard transistor packages which are easily mounted and handled.

In addition to higher performance than fixed regulators, the LM150 series offers full overload protection available only in IC's. Included on the chip are current limit, thermal overload protection and safe area protection. All overload protection circuitry remains fully functional even if the adjustment terminal is accidentally disconnected.

Normally, no capacitors are needed unless the device is situated more than 6 inches from the input filter capacitors in which case an input bypass is needed. An output capacitor can be added to improve transient response, while bypassing the adjustment pin will increase the regulator's ripple rejection.

Besides replacing fixed regulators or discrete designs, the LM150 is useful in a wide variety of other applications. Since the regulator is "floating" and sees only the input-to-output differential voltage, supplies of several hundred volts can be regulated as long as the maximum input to output differential is not exceeded, i.e., avoid short-circuiting the output.

By connecting a fixed resistor between the adjustment pin and output, the LM150 can be used as a precision current regulator. Supplies with electronic shutdown can be achieved by clamping the adjustment terminal to ground which programs the output to 1.2V where most loads draw little current.

The part numbers in the LM150 series which have a K suffix are packaged in a standard Steel TO-3 package, while those with a T suffix are packaged in a TO-220 plastic package. The LM150 is rated for $-55^{\circ}\text{C} \leq T_J \leq +150^{\circ}\text{C}$, while the LM350A is rated for $-40^{\circ}\text{C} \leq T_J \leq +125^{\circ}\text{C}$, and the LM350 is rated for $0^{\circ}\text{C} \leq T_J \leq +125^{\circ}\text{C}$.



Please be aware that an important notice concerning availability, standard warranty, and use in critical applications of Texas Instruments semiconductor products and disclaimers thereto appears at the end of this data sheet.

All trademarks are the property of their respective owners.

Connection Diagram

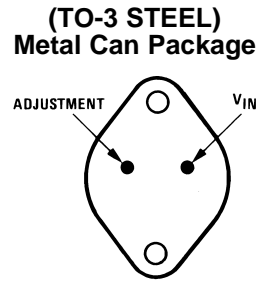

Case is Output

Figure 1. Bottom View

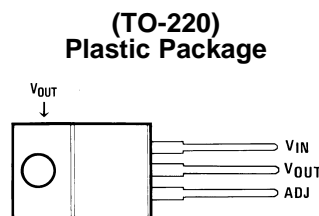

Figure 2. Front View



These devices have limited built-in ESD protection. The leads should be shorted together or the device placed in conductive foam during storage or handling to prevent electrostatic damage to the MOS gates.

Absolute Maximum Ratings ^{(1) (2)}

Power Dissipation	Internally Limited
Input-Output Voltage Differential	+35V
Storage Temperature	-65°C to +150°C
Lead Temperature	
Metal Package (Soldering, 10 sec.)	300°C
Plastic Package (Soldering, 4 sec.)	260°C
ESD Tolerance	TBD
Operating Temperature Range	
LM150	-55°C ≤ T _J ≤ +150°C
LM350A	-40°C ≤ T _J ≤ +125°C
LM350	0°C ≤ T _J ≤ +125°C

- (1) Absolute Maximum Ratings indicate limits beyond which damage to the device may occur. Operating Ratings indicate conditions for which the device is intended to be functional, but do not guarantee specific performance limits. For guaranteed specifications and test conditions, see the Electrical Characteristics.
- (2) Refer to RETS150K drawing for military specifications of the LM150K.

Electrical Characteristics

Specifications with standard type face are for $T_J = 25^\circ\text{C}$, and those with **boldface type** apply over **full Operating Temperature Range**. Unless otherwise specified, $V_{IN} - V_{OUT} = 5\text{V}$, and $I_{OUT} = 10\text{ mA}$. ⁽¹⁾

Parameter	Conditions	LM150			Units
		Min	Typ	Max	
Reference Voltage	$3\text{V} \leq (V_{IN} - V_{OUT}) \leq 35\text{V}$, $10\text{ mA} \leq I_{OUT} \leq 3\text{A}$, $P \leq 30\text{W}$	1.20	1.25	1.30	V
Line Regulation	$3\text{V} \leq (V_{IN} - V_{OUT}) \leq 35\text{V}$ ⁽²⁾		0.005	0.01	%/V
			0.02	0.05	%/V
Load Regulation	$10\text{ mA} \leq I_{OUT} \leq 3\text{A}$ ⁽²⁾		0.1	0.3	%
			0.3	1	%
Thermal Regulation	20 ms Pulse		0.002	0.01	%/W
Adjustment Pin Current			50	100	μA
Adjustment Pin Current Change	$10\text{ mA} \leq I_{OUT} \leq 3\text{A}$, $3\text{V} \leq (V_{IN} - V_{OUT}) \leq 35\text{V}$		0.2	5	μA
Temperature Stability	$T_{MIN} \leq T_J \leq T_{MAX}$		1		%
Minimum Load Current	$V_{IN} - V_{OUT} = 35\text{V}$		3.5	5	mA
Current Limit	$V_{IN} - V_{OUT} \leq 10\text{V}$	3.0	4.5		A
	$V_{IN} - V_{OUT} = 30\text{V}$	0.3	1		A
RMS Output Noise, % of V_{OUT}	$10\text{ Hz} \leq f \leq 10\text{ kHz}$		0.001		%
Ripple Rejection Ratio	$V_{OUT} = 10\text{V}$, $f = 120\text{ Hz}$, $C_{ADJ} = 0\text{ }\mu\text{F}$		65		dB
	$V_{OUT} = 10\text{V}$, $f = 120\text{ Hz}$, $C_{ADJ} = 10\text{ }\mu\text{F}$	66	86		dB
Long-Term Stability	$T_J = 125^\circ\text{C}$, 1000 hrs		0.3	1	%
Thermal Resistance, Junction to Case	K Package		1.2	1.5	$^\circ\text{C/W}$
Thermal Resistance, Junction to Ambient (No Heat Sink)	K Package		35		$^\circ\text{C/W}$

- (1) These specifications are applicable for power dissipations up to 30W for the TO-3 (K) package and 25W for the TO-220 (T) package. Power dissipation is guaranteed at these values up to 15V input-output differential. Above 15V differential, power dissipation will be limited by internal protection circuitry. All limits (i.e., the numbers in the Min. and Max. columns) are guaranteed to National's AOQL (Average Outgoing Quality Level).
- (2) Regulation is measured at a constant junction temperature, using pulse testing with a low duty cycle. Changes in output voltage due to heating effects are covered under the specifications for thermal regulation.

Electrical Characteristics

Specifications with standard type face are for $T_J = 25^\circ\text{C}$, and those with **boldface type** apply over **full Operating Temperature Range**. Unless otherwise specified, $V_{IN} - V_{OUT} = 5\text{V}$, and $I_{OUT} = 10\text{ mA}$. ⁽¹⁾

Parameter	Conditions	LM350A			LM350			Units
		Min	Typ	Max	Min	Typ	Max	
Reference Voltage	$I_{OUT} = 10\text{ mA}$, $T_J = 25^\circ\text{C}$ $3\text{V} \leq (V_{IN} - V_{OUT}) \leq 35\text{V}$, $10\text{ mA} \leq I_{OUT} \leq 3\text{A}$, $P \leq 30\text{W}$	1.23 8	1.25 0	1.26 2				V
		1.22 5	1.25 0	1.27 0	1.20	1.25	1.30	V
Line Regulation	$3\text{V} \leq (V_{IN} - V_{OUT}) \leq 35\text{V}$ ⁽²⁾		0.00 5	0.01		0.00 5	0.03	%/V
			0.02	0.05		0.02	0.07	%/V
Load Regulation	$10\text{ mA} \leq I_{OUT} \leq 3\text{A}$ ⁽²⁾		0.1	0.3		0.1	0.5	%
			0.3	1		0.3	1.5	%
Thermal Regulation	20 ms Pulse		0.00 2	0.01		0.00 2	0.03	%/W
Adjustment Pin Current			50	100		50	100	μA
Adjustment Pin Current Change	$10\text{ mA} \leq I_{OUT} \leq 3\text{A}$, $3\text{V} \leq (V_{IN} - V_{OUT}) \leq 35\text{V}$		0.2	5		0.2	5	μA
Temperature Stability	$T_{MIN} \leq T_J \leq T_{MAX}$		1			1		%
Minimum Load Current	$V_{IN} - V_{OUT} = 35\text{V}$		3.5	10		3.5	10	mA
Current Limit	$V_{IN} - V_{OUT} \leq 10\text{V}$	3.0	4.5		3.0	4.5		A
	$V_{IN} - V_{OUT} = 30\text{V}$	0.3	1		0.25	1		A
RMS Output Noise, % of V_{OUT}	$10\text{ Hz} \leq f \leq 10\text{ kHz}$		0.00 1			0.00 1		%
Ripple Rejection Ratio	$V_{OUT} = 10\text{V}$, $f = 120\text{ Hz}$, $C_{ADJ} = 0\text{ }\mu\text{F}$		65			65		dB
	$V_{OUT} = 10\text{V}$, $f = 120\text{ Hz}$, $C_{ADJ} = 10\text{ }\mu\text{F}$	66	86		66	86		dB
Long-Term Stability	$T_J = 125^\circ\text{C}$, 1000 hrs		0.25	1		0.25	1	%
Thermal Resistance, Junction to Case	K Package					1.2	1.5	$^\circ\text{C/W}$
	T Package		3	4		3	4	$^\circ\text{C/W}$
Thermal Resistance, Junction to Ambient (No Heat Sink)	K Package					35		$^\circ\text{C/W}$
	T Package		50			50		$^\circ\text{C/W}$

- (1) These specifications are applicable for power dissipations up to 30W for the TO-3 (K) package and 25W for the TO-220 (T) package. Power dissipation is guaranteed at these values up to 15V input-output differential. Above 15V differential, power dissipation will be limited by internal protection circuitry. All limits (i.e., the numbers in the Min. and Max. columns) are guaranteed to National's AOQL (Average Outgoing Quality Level).
- (2) Regulation is measured at a constant junction temperature, using pulse testing with a low duty cycle. Changes in output voltage due to heating effects are covered under the specifications for thermal regulation.

Typical Performance Characteristics

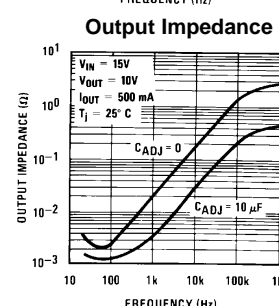
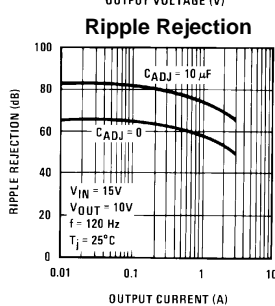
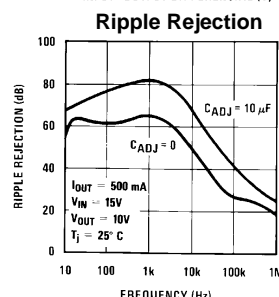
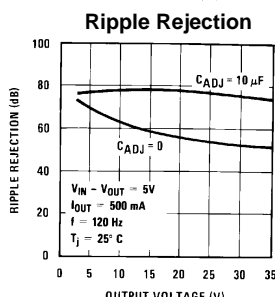
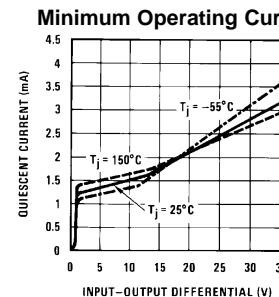
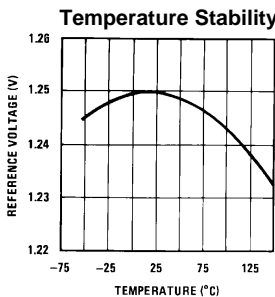
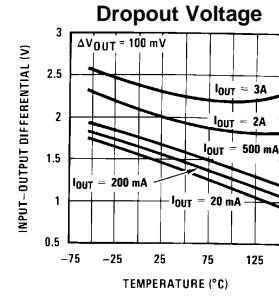
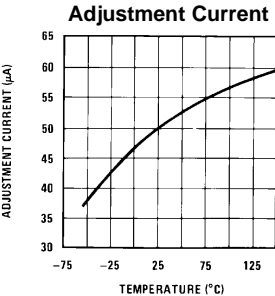
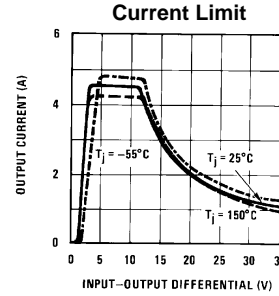
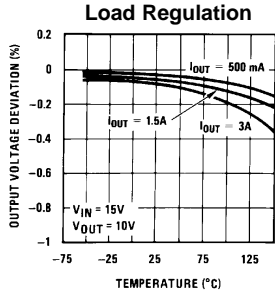

Typical Performance Characteristics (continued)



APPLICATION HINTS

In operation, the LM150 develops a nominal 1.25V reference voltage, V_{REF} , between the output and adjustment terminal. The reference voltage is impressed across program resistor R1 and, since the voltage is constant, a constant current I_1 then flows through the output set resistor R2, giving an output voltage of

$$V_{OUT} = V_{REF} \left(1 + \frac{R_2}{R_1} \right) + I_{ADJ} R_2. \quad (1)$$

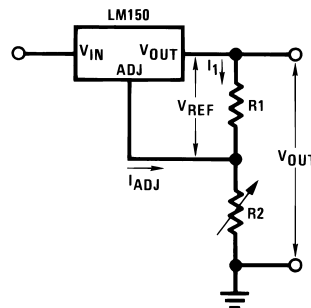

Since the 50 μ A current from the adjustment terminal represents an error term, the LM150 was designed to minimize I_{ADJ} and make it very constant with line and load changes. To do this, all quiescent operating current is returned to the output establishing a minimum load current requirement. If there is insufficient load on the output, the output will rise.

EXTERNAL CAPACITORS

An input bypass capacitor is recommended. A 0.1 μ F disc or 1 μ F solid tantalum on the input is suitable input bypassing for almost all applications. The device is more sensitive to the absence of input bypassing when adjustment or output capacitors are used but the above values will eliminate the possibility of problems.

The adjustment terminal can be bypassed to ground on the LM150 to improve ripple rejection. This bypass capacitor prevents ripple from being amplified as the output voltage is increased. With a 10 μ F bypass capacitor 86 dB ripple rejection is obtainable at any output level. Increases over 10 μ F do not appreciably improve the ripple rejection at frequencies above 120 Hz. If the bypass capacitor is used, it is sometimes necessary to include protection diodes to prevent the capacitor from discharging through internal low current paths and damaging the device.

In general, the best type of capacitors to use is solid tantalum. Solid tantalum capacitors have low impedance even at high frequencies. Depending upon capacitor construction, it takes about 25 μ F in aluminum electrolytic to equal 1 μ F solid tantalum at high frequencies. Ceramic capacitors are also good at high frequencies, but some types have a large decrease in capacitance at frequencies around 0.5 MHz. For this reason, 0.01 μ F disc may seem to work better than a 0.1 μ F disc as a bypass.

Although the LM150 is stable with no output capacitors, like any feedback circuit, certain values of external capacitance can cause excessive ringing. This occurs with values between 500 pF and 5000 pF. A 1 μ F solid tantalum (or 25 μ F aluminum electrolytic) on the output swamps this effect and insures stability.

LOAD REGULATION

The LM150 is capable of providing extremely good load regulation but a few precautions are needed to obtain maximum performance. The current set resistor connected between the adjustment terminal and the output terminal (usually 240Ω) should be tied directly to the output (case) of the regulator rather than near the load. This eliminates line drops from appearing effectively in series with the reference and degrading regulation. For example, a 15V regulator with 0.05Ω resistance between the regulator and load will have a load regulation due to line resistance of $0.05\Omega \times I_{OUT}$. If the set resistor is connected near the load the effective line resistance will be $0.05\Omega (1 + R2/R1)$ or in this case, 11.5 times worse.

Figure 3 shows the effect of resistance between the regulator and 240Ω set resistor.

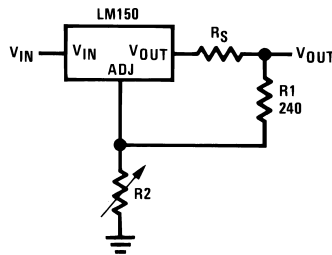

Figure 3. Regulator with Line Resistance in Output Lead

With the TO-3 package, it is easy to minimize the resistance from the case to the set resistor, by using two separate leads to the case. The ground of R2 can be returned near the ground of the load to provide remote ground sensing and improve load regulation.

PROTECTION DIODES

When external capacitors are used with *any* IC regulator it is sometimes necessary to add protection diodes to prevent the capacitors from discharging through low current points into the regulator. Most 10 μF capacitors have low enough internal series resistance to deliver 20A spikes when shorted. Although the surge is short, there is enough energy to damage parts of the IC.

When an output capacitor is connected to a regulator and the input is shorted, the output capacitor will discharge into the output of the regulator. The discharge current depends on the value of the capacitor, the output voltage of the regulator, and the rate of decrease of V_{IN} . In the LM150, this discharge path is through a large junction that is able to sustain 25A surge with no problem. This is not true of other types of positive regulators. For output capacitors of 25 μF or less, there is no need to use diodes.

The bypass capacitor on the adjustment terminal can discharge through a low current junction. Discharge occurs when *either* the input or output is shorted. Internal to the LM150 is a 50Ω resistor which limits the peak discharge current. No protection is needed for output voltages of 25V or less and 10 μF capacitance. Figure 4 shows an LM150 with protection diodes included for use with outputs greater than 25V and high values of output capacitance.

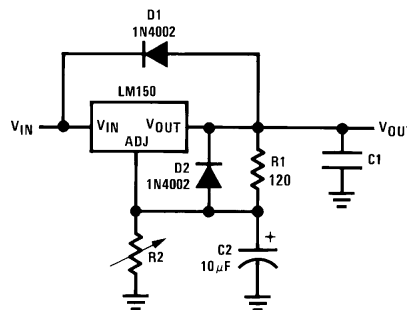

D1 protects against C1
D2 protects against C2

Figure 4. Regulator with Protection Diodes

$$V_{OUT} = 1.25V \left(1 + \frac{R2}{R1} \right) + I_{ADJ}R2 \tag{2}$$

Schematic Diagram

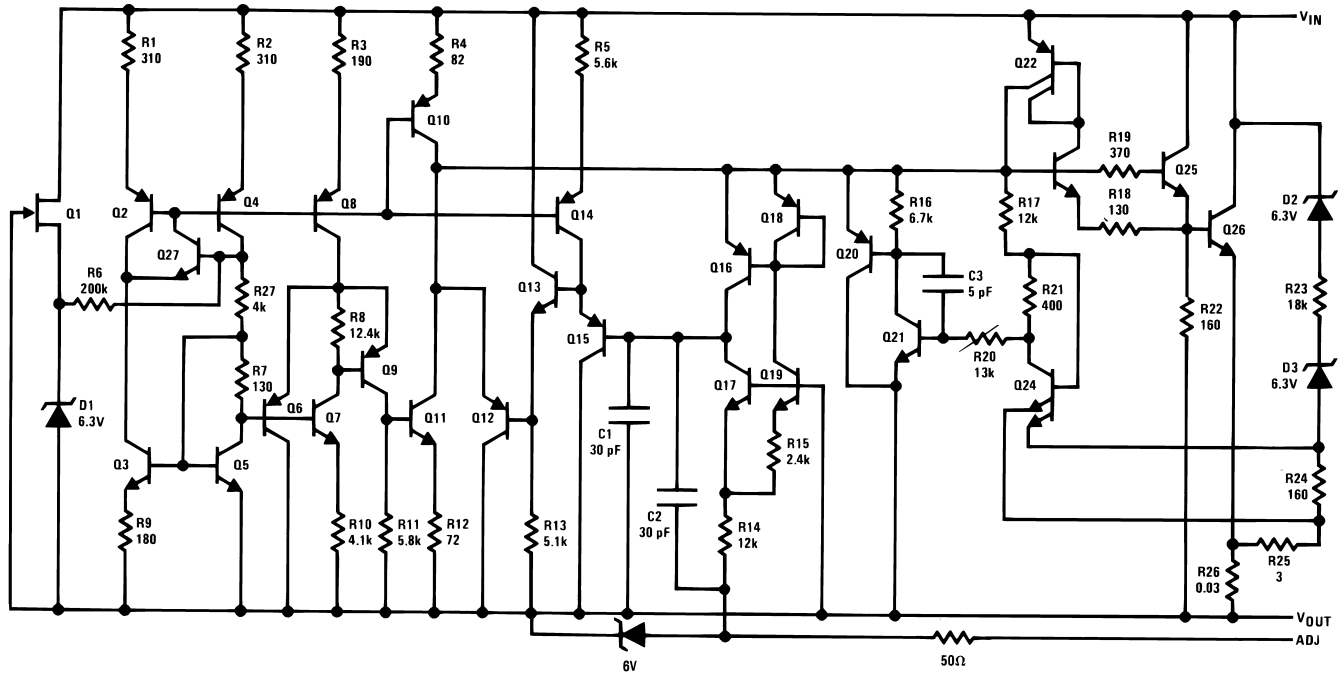
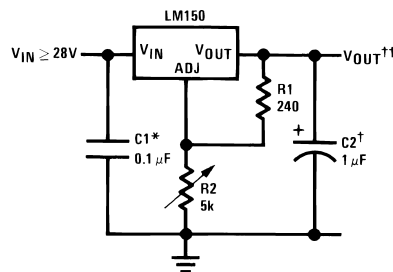

Figure 5. Schematic Diagram

Typical Applications

Figure 6. 1.2V–25V Adjustable Regulator



Full output current not available at high input-output voltages.

†Optional—improves transient response. Output capacitors in the range of 1 μF to 1000 μF of aluminum or tantalum electrolytic are commonly used to provide improved output impedance and rejection of transients.

*Needed if device is more than 6 inches from filter capacitors.

$$\dagger\dagger V_{OUT} = 1.25V \left(1 + \frac{R2}{R1} \right) + I_{ADJ} (R2)$$

Note: Usually R1 = 240Ω for LM150 and R1 = 120Ω for LM350.

(3)

Figure 7. Precision Power Regulator with Low Temperature Coefficient

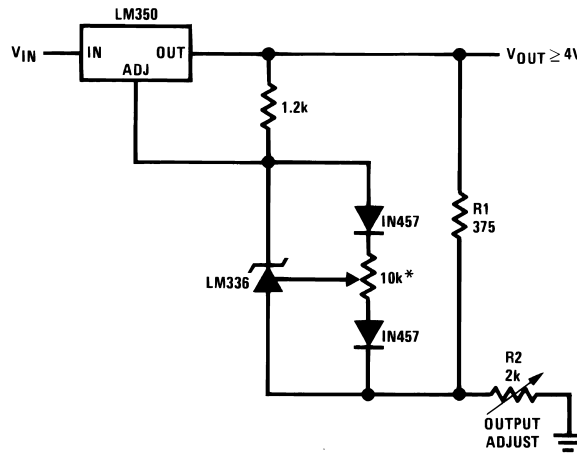

*Adjust for 3.75V across R1

Figure 8. Slow Turn-ON 15V Regulator

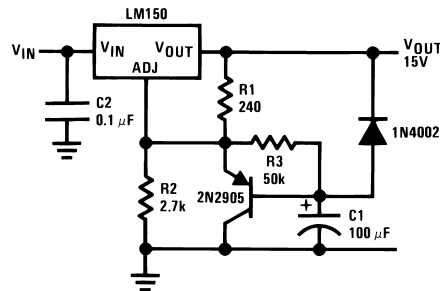
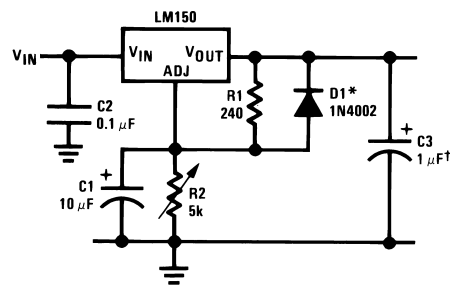

Figure 9. Adjustable Regulator with Improved Ripple Rejection



†Solid tantalum

*Discharges C1 if output is shorted to ground

Figure 10. High Stability 10V Regulator

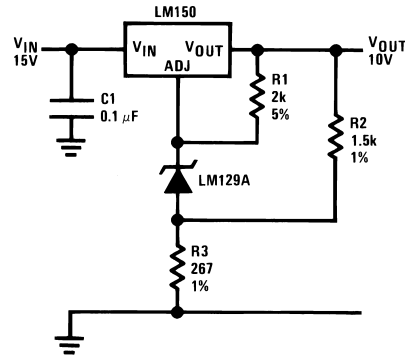
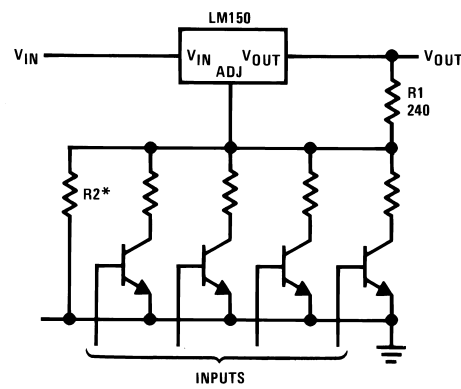

Figure 11. Digitally Selected Outputs



*Sets maximum V_{OUT}

Figure 12. Regulator and Voltage Reference

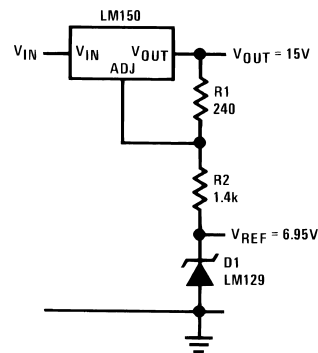
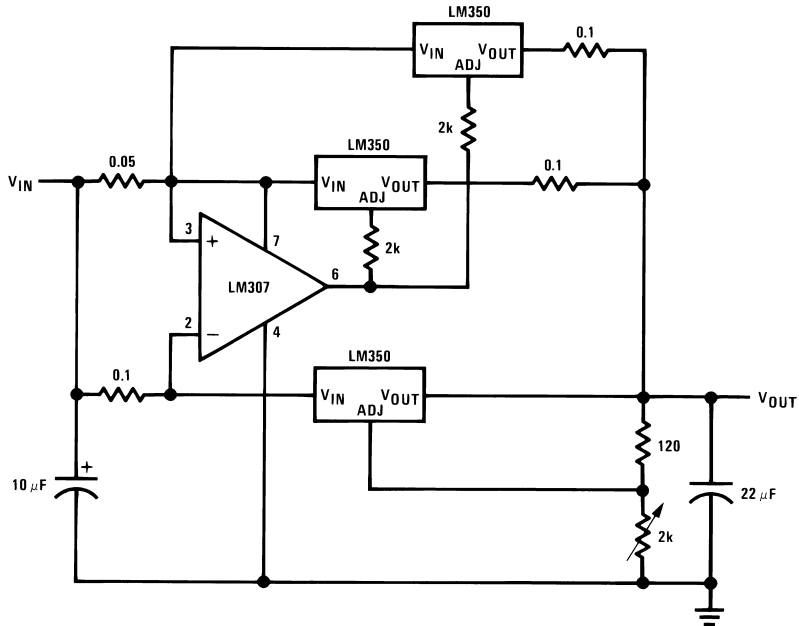
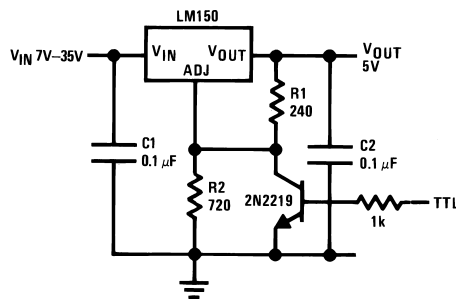

Figure 13. 10A Regulator



*Minimum load current 50 mA

Figure 14. 5V Logic Regulator with Electronic Shutdown*



*Min output \approx 1.2V

Figure 15. 0 to 30V Regulator

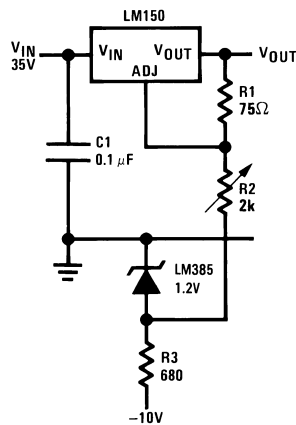

Full output current not available at high input-output voltages

Figure 16. 5A Constant Voltage/Constant Current Regulator

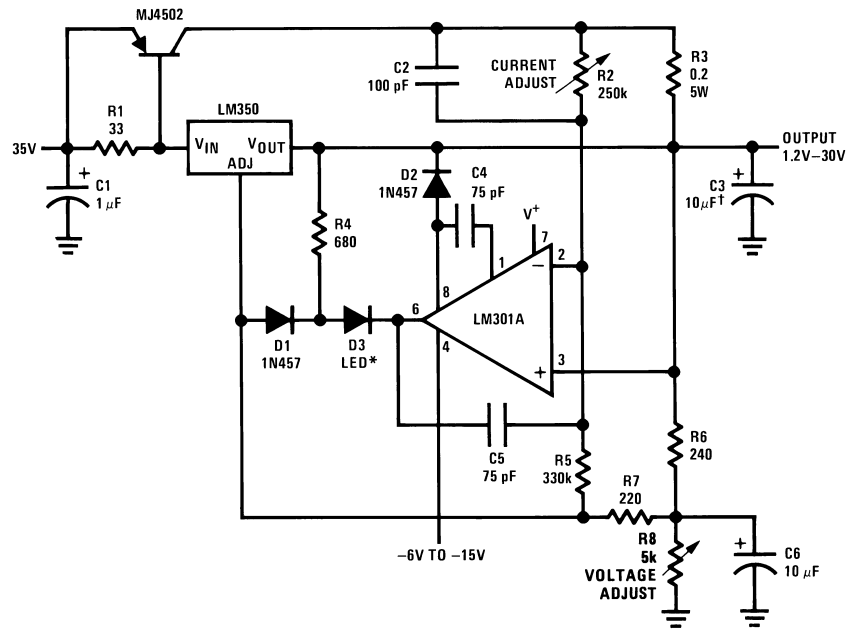

†Solid tantalum

*Lights in constant current mode

Figure 17. 12V Battery Charger

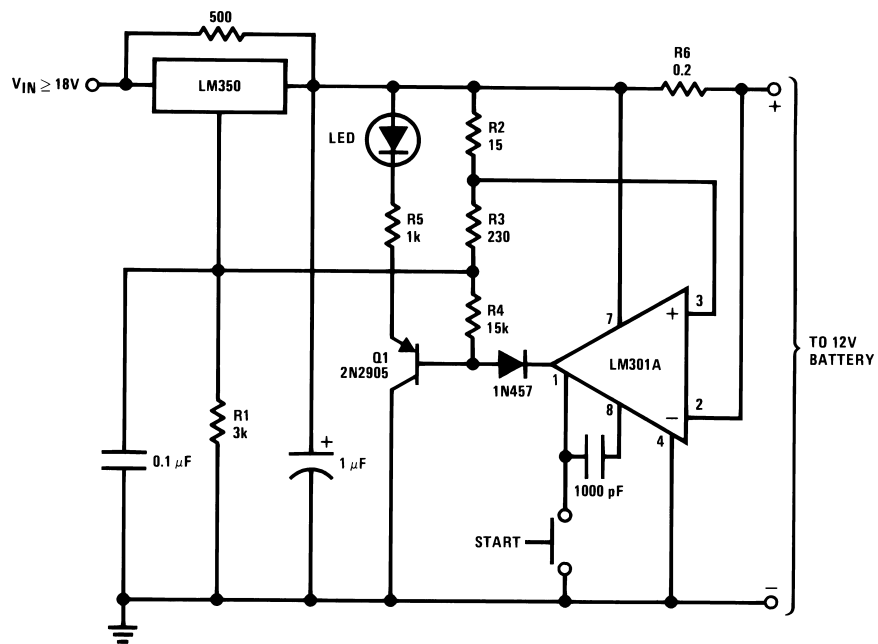

Figure 22. Tracking Preregulator

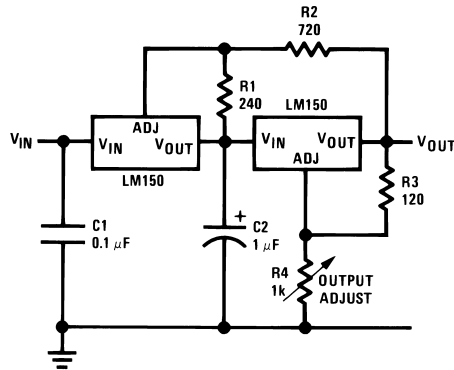
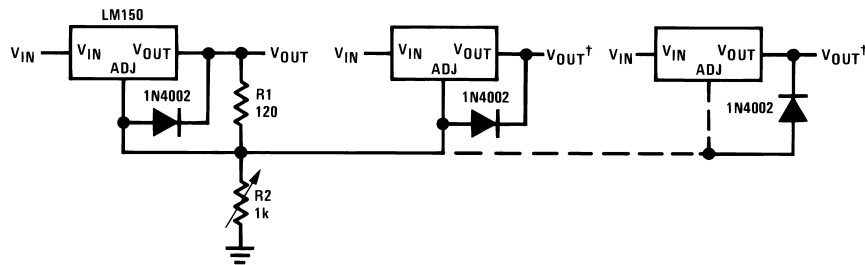

Figure 23. Adjusting Multiple On-Card Regulators with Single Control*



†Minimum load—10 mA
 *All outputs within ± 100 mV

Figure 24. AC Voltage Regulator

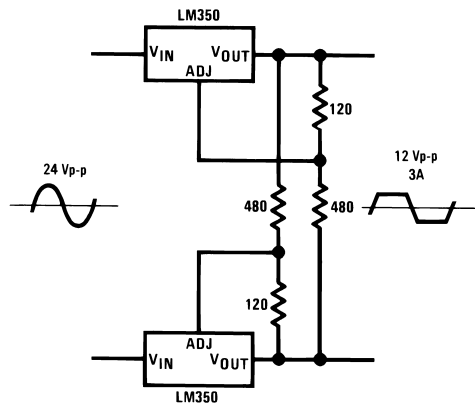
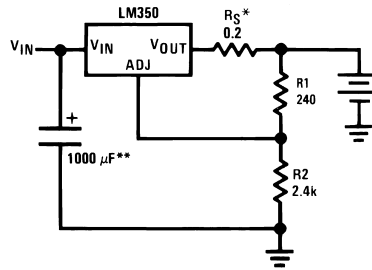

Figure 25. Simple 12V Battery Charger



* R_S —sets output impedance of charger: $Z_{OUT} = R_S \left(1 + \frac{R_2}{R_1} \right)$

Use of R_S allows low charging rates with fully charged battery.

**1000 μ F is recommended to filter out any input transients

Figure 26. Temperature Controller

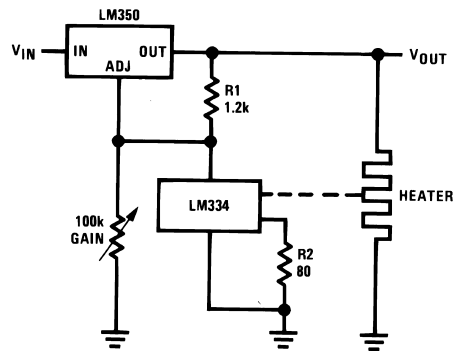

Figure 27. Light Controller

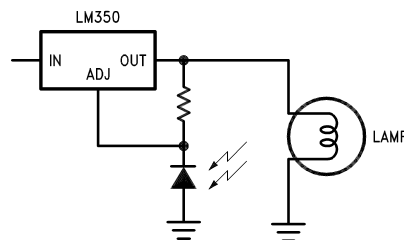

Figure 28. Adjustable 10A Regulator

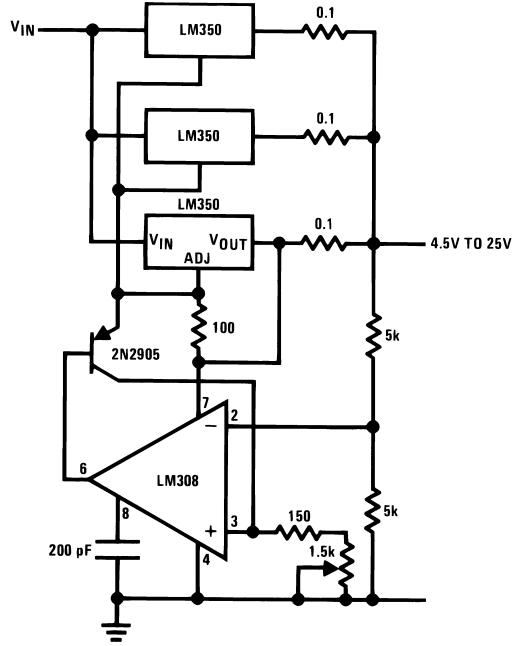
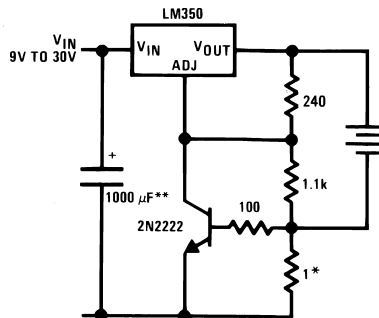

Figure 29. Current Limited 6V Charger



*Sets peak current (2A for 0.3Ω)

**1000 μF is recommended to filter out any input transients.

Figure 30. 6A Regulator

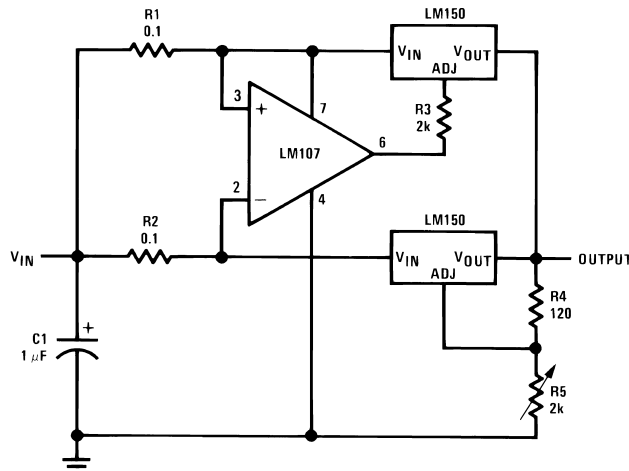

PACKAGING INFORMATION

Orderable Device	Status (1)	Package Type	Package Drawing	Pins	Package Qty	Eco Plan (2)	Lead/Ball Finish	MSL Peak Temp (3)	Samples (Requires Login)
LM350AT	ACTIVE	TO-220	NDE	3	45	TBD	CU SNPB	Level-1-NA-UNLIM	
LM350AT/NOPB	ACTIVE	TO-220	NDE	3	45	Green (RoHS & no Sb/Br)	CU SN	Level-1-NA-UNLIM	
LM350K STEEL	ACTIVE	TO-3	NDS	2	50	TBD	POST-PLATE	Level-1-NA-UNLIM	
LM350K STEEL/NOPB	ACTIVE	TO-3	NDS	2	50	Green (RoHS & no Sb/Br)	POST-PLATE	Level-1-NA-UNLIM	
LM350T	ACTIVE	TO-220	NDE	3	45	TBD	CU SNPB	Level-1-NA-UNLIM	
LM350T/NOPB	ACTIVE	TO-220	NDE	3	45	Green (RoHS & no Sb/Br)	CU SN	Level-1-NA-UNLIM	

(1) The marketing status values are defined as follows:

ACTIVE: Product device recommended for new designs.

LIFEBUY: TI has announced that the device will be discontinued, and a lifetime-buy period is in effect.

NRND: Not recommended for new designs. Device is in production to support existing customers, but TI does not recommend using this part in a new design.

PREVIEW: Device has been announced but is not in production. Samples may or may not be available.

OBSOLETE: TI has discontinued the production of the device.

(2) Eco Plan - The planned eco-friendly classification: Pb-Free (RoHS), Pb-Free (RoHS Exempt), or Green (RoHS & no Sb/Br) - please check <http://www.ti.com/productcontent> for the latest availability information and additional product content details.

TBD: The Pb-Free/Green conversion plan has not been defined.

Pb-Free (RoHS): TI's terms "Lead-Free" or "Pb-Free" mean semiconductor products that are compatible with the current RoHS requirements for all 6 substances, including the requirement that lead not exceed 0.1% by weight in homogeneous materials. Where designed to be soldered at high temperatures, TI Pb-Free products are suitable for use in specified lead-free processes.

Pb-Free (RoHS Exempt): This component has a RoHS exemption for either 1) lead-based flip-chip solder bumps used between the die and package, or 2) lead-based die adhesive used between the die and leadframe. The component is otherwise considered Pb-Free (RoHS compatible) as defined above.

Green (RoHS & no Sb/Br): TI defines "Green" to mean Pb-Free (RoHS compatible), and free of Bromine (Br) and Antimony (Sb) based flame retardants (Br or Sb do not exceed 0.1% by weight in homogeneous material)

(3) MSL, Peak Temp. -- The Moisture Sensitivity Level rating according to the JEDEC industry standard classifications, and peak solder temperature.

Important Information and Disclaimer: The information provided on this page represents TI's knowledge and belief as of the date that it is provided. TI bases its knowledge and belief on information provided by third parties, and makes no representation or warranty as to the accuracy of such information. Efforts are underway to better integrate information from third parties. TI has taken and continues to take reasonable steps to provide representative and accurate information but may not have conducted destructive testing or chemical analysis on incoming materials and chemicals. TI and TI suppliers consider certain information to be proprietary, and thus CAS numbers and other limited information may not be available for release.

In no event shall TI's liability arising out of such information exceed the total purchase price of the TI part(s) at issue in this document sold by TI to Customer on an annual basis.

NDS0002A

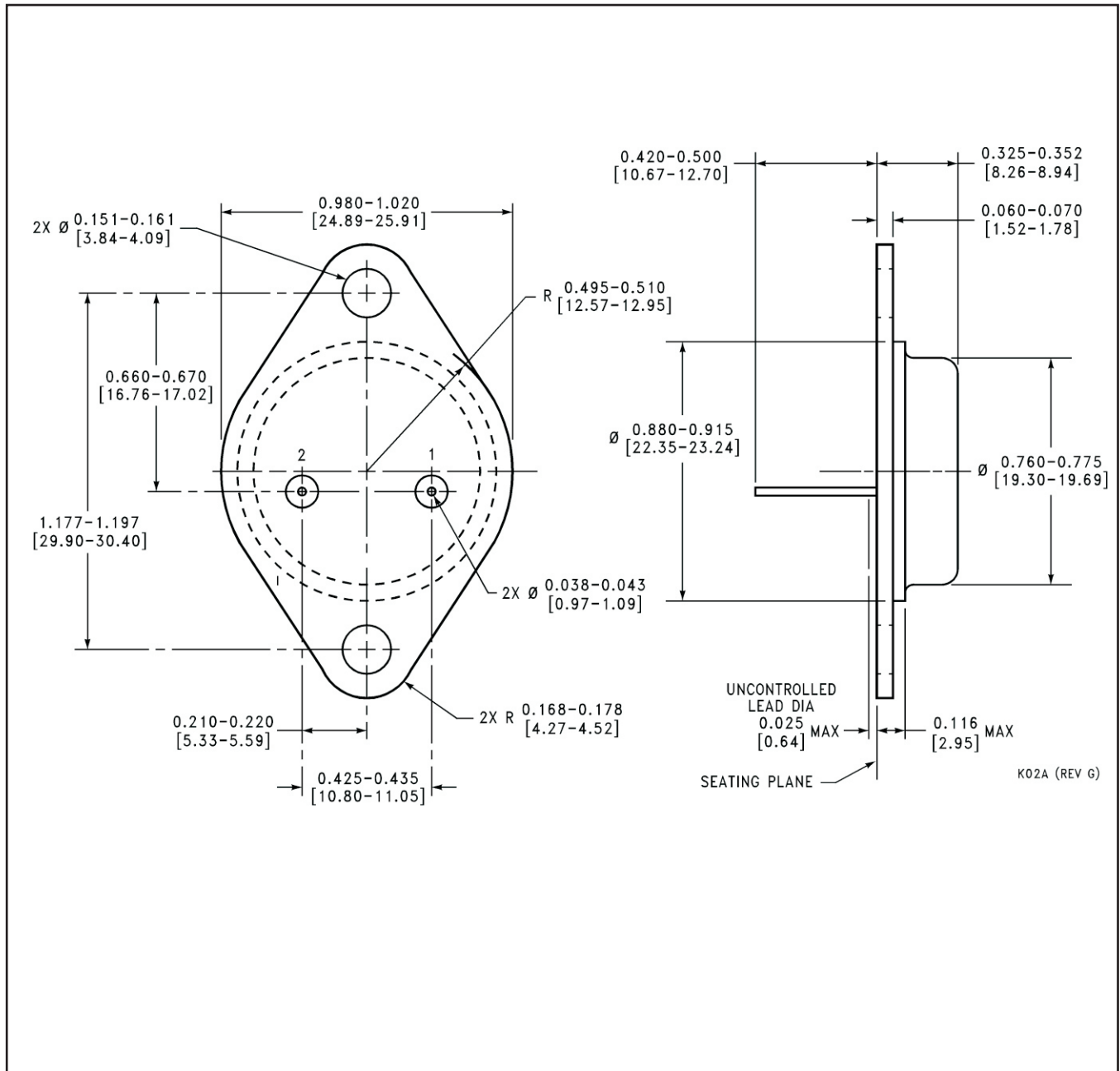

NDE0003B

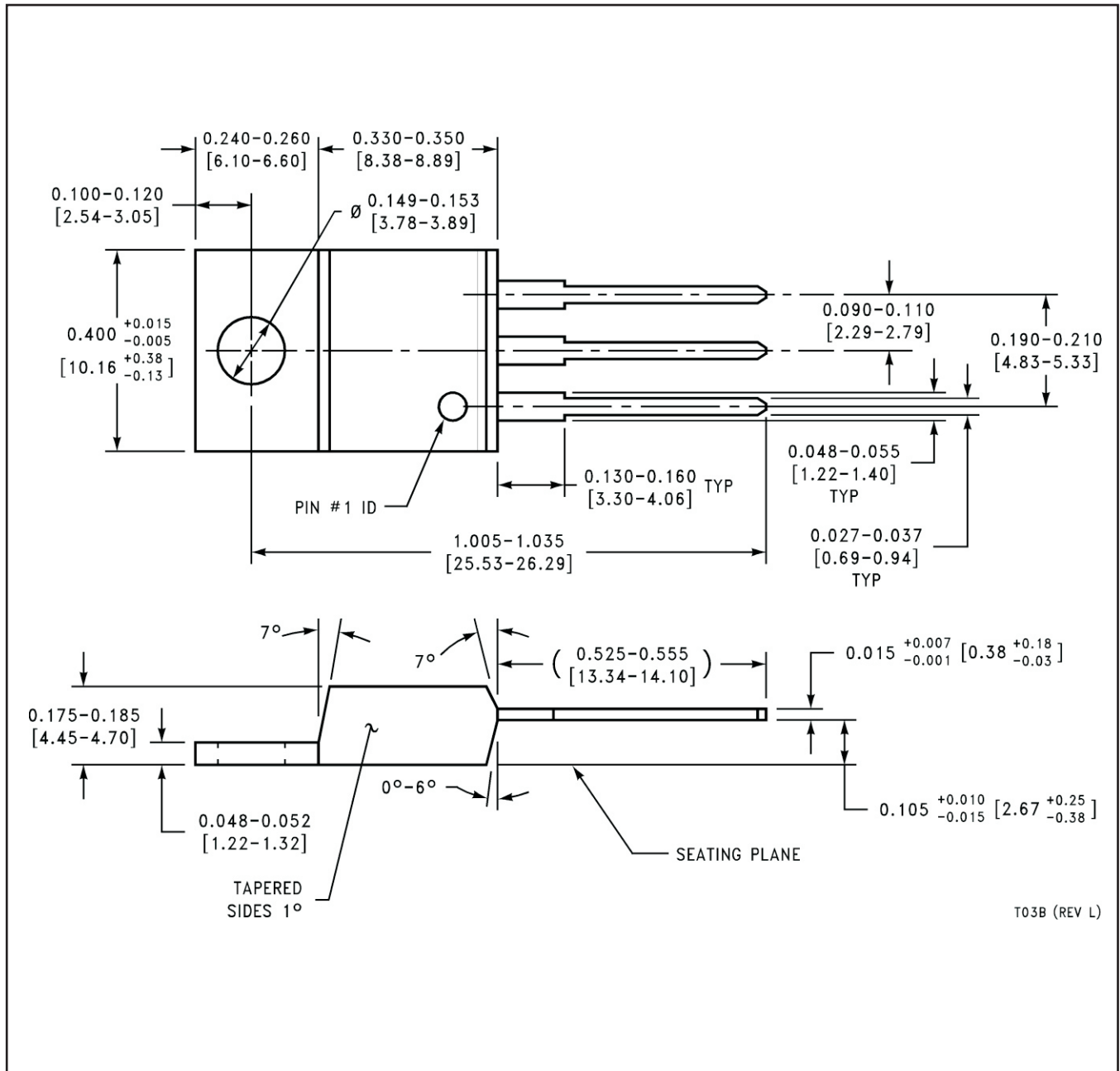

IMPORTANT NOTICE

Texas Instruments Incorporated and its subsidiaries (TI) reserve the right to make corrections, enhancements, improvements and other changes to its semiconductor products and services per JESD46, latest issue, and to discontinue any product or service per JESD48, latest issue. Buyers should obtain the latest relevant information before placing orders and should verify that such information is current and complete. All semiconductor products (also referred to herein as "components") are sold subject to TI's terms and conditions of sale supplied at the time of order acknowledgment.

TI warrants performance of its components to the specifications applicable at the time of sale, in accordance with the warranty in TI's terms and conditions of sale of semiconductor products. Testing and other quality control techniques are used to the extent TI deems necessary to support this warranty. Except where mandated by applicable law, testing of all parameters of each component is not necessarily performed.

TI assumes no liability for applications assistance or the design of Buyers' products. Buyers are responsible for their products and applications using TI components. To minimize the risks associated with Buyers' products and applications, Buyers should provide adequate design and operating safeguards.

TI does not warrant or represent that any license, either express or implied, is granted under any patent right, copyright, mask work right, or other intellectual property right relating to any combination, machine, or process in which TI components or services are used. Information published by TI regarding third-party products or services does not constitute a license to use such products or services or a warranty or endorsement thereof. Use of such information may require a license from a third party under the patents or other intellectual property of the third party, or a license from TI under the patents or other intellectual property of TI.

Reproduction of significant portions of TI information in TI data books or data sheets is permissible only if reproduction is without alteration and is accompanied by all associated warranties, conditions, limitations, and notices. TI is not responsible or liable for such altered documentation. Information of third parties may be subject to additional restrictions.

Resale of TI components or services with statements different from or beyond the parameters stated by TI for that component or service voids all express and any implied warranties for the associated TI component or service and is an unfair and deceptive business practice. TI is not responsible or liable for any such statements.

Buyer acknowledges and agrees that it is solely responsible for compliance with all legal, regulatory and safety-related requirements concerning its products, and any use of TI components in its applications, notwithstanding any applications-related information or support that may be provided by TI. Buyer represents and agrees that it has all the necessary expertise to create and implement safeguards which anticipate dangerous consequences of failures, monitor failures and their consequences, lessen the likelihood of failures that might cause harm and take appropriate remedial actions. Buyer will fully indemnify TI and its representatives against any damages arising out of the use of any TI components in safety-critical applications.

In some cases, TI components may be promoted specifically to facilitate safety-related applications. With such components, TI's goal is to help enable customers to design and create their own end-product solutions that meet applicable functional safety standards and requirements. Nonetheless, such components are subject to these terms.

No TI components are authorized for use in FDA Class III (or similar life-critical medical equipment) unless authorized officers of the parties have executed a special agreement specifically governing such use.

Only those TI components which TI has specifically designated as military grade or "enhanced plastic" are designed and intended for use in military/aerospace applications or environments. Buyer acknowledges and agrees that any military or aerospace use of TI components which have **not** been so designated is solely at the Buyer's risk, and that Buyer is solely responsible for compliance with all legal and regulatory requirements in connection with such use.

TI has specifically designated certain components as meeting ISO/TS16949 requirements, mainly for automotive use. In any case of use of non-designated products, TI will not be responsible for any failure to meet ISO/TS16949.

Products

Audio	www.ti.com/audio
Amplifiers	amplifier.ti.com
Data Converters	dataconverter.ti.com
DLP® Products	www.dlp.com
DSP	dsp.ti.com
Clocks and Timers	www.ti.com/clocks
Interface	interface.ti.com
Logic	logic.ti.com
Power Mgmt	power.ti.com
Microcontrollers	microcontroller.ti.com
RFID	www.ti-rfid.com
OMAP Applications Processors	www.ti.com/omap
Wireless Connectivity	www.ti.com/wirelessconnectivity

Applications

Automotive and Transportation	www.ti.com/automotive
Communications and Telecom	www.ti.com/communications
Computers and Peripherals	www.ti.com/computers
Consumer Electronics	www.ti.com/consumer-apps
Energy and Lighting	www.ti.com/energy
Industrial	www.ti.com/industrial
Medical	www.ti.com/medical
Security	www.ti.com/security
Space, Avionics and Defense	www.ti.com/space-avionics-defense
Video and Imaging	www.ti.com/video

TI E2E Community

e2e.ti.com