

**6-Lead Ultra Thin Dual Flat, No Lead Package (HXA) - 1.3x2x0.60 mm Body [UDFN]
Micrel Legacy Package TDFN2013-6LD-PL-1**

Note: For the most current package drawings, please see the Microchip Packaging Specification located at <http://www.microchip.com/packaging>

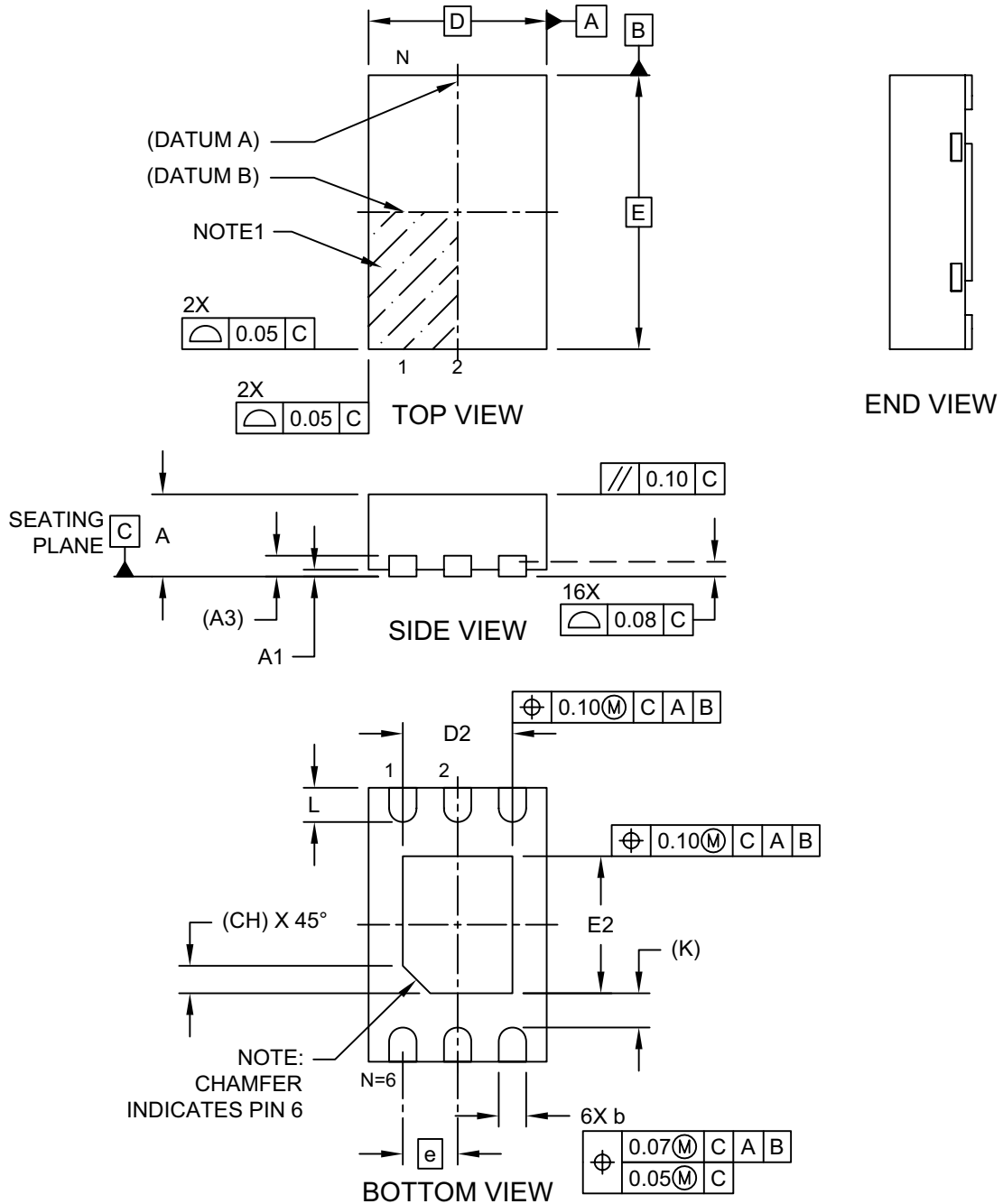

**6-Lead Ultra Thin Dual Flat, No Lead Package (HXA) - 1.3x2x0.60 mm Body [UDFN]
Micrel Legacy Package TDFN2013-6LD-PL-1**

Note: For the most current package drawings, please see the Microchip Packaging Specification located at <http://www.microchip.com/packaging>

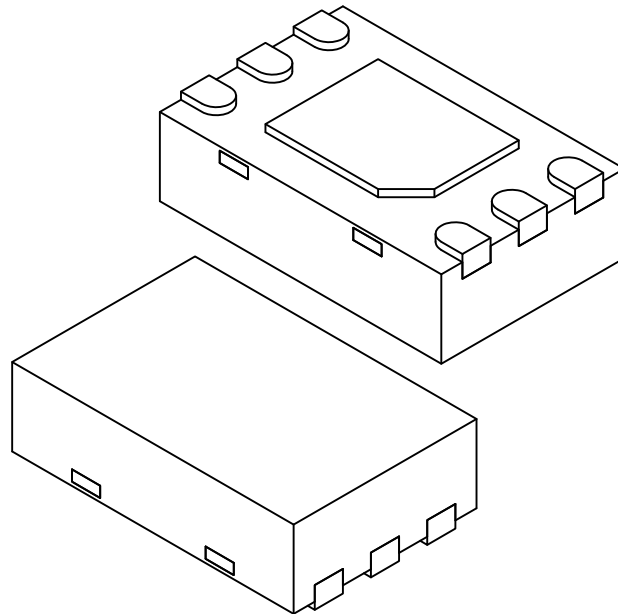

Units		MILLIMETERS		
		MIN	NOM	MAX
Dimension Limits				
Number of Terminals	N	6		
Pitch	e	0.40 BSC		
Overall Height	A	0.50	0.55	0.60
Standoff	A1	0.00	0.02	0.05
Terminal Thickness	A3	0.152 REF		
Overall Length	D	1.30 BSC		
Exposed Pad Length	D2	0.75	0.80	0.85
Overall Width	E	2.00 BSC		
Exposed Pad Width	E2	0.95	1.00	1.05
Terminal Width	b	0.15	0.20	0.25
Terminal Length	L	0.20	0.25	0.30
Exposed Pad Index Chamfer	CH	0.20 REF		
Terminal-to-Exposed-Pad	K	0.25 REF		

Notes:

1. Pin 1 visual index feature may vary, but must be located within the hatched area.
2. Package is saw singulated
3. Dimensioning and tolerancing per ASME Y14.5M
 - BSC: Basic Dimension. Theoretically exact value shown without tolerances.
 - REF: Reference Dimension, usually without tolerance, for information purposes only.

**6-Lead Ultra Thin Dual Flat, No Lead Package (HXA) - 1.3x2x0.60 mm Body [UDFN]
Micrel Legacy Package TDFN2013-6LD-PL-1**

Note: For the most current package drawings, please see the Microchip Packaging Specification located at <http://www.microchip.com/packaging>

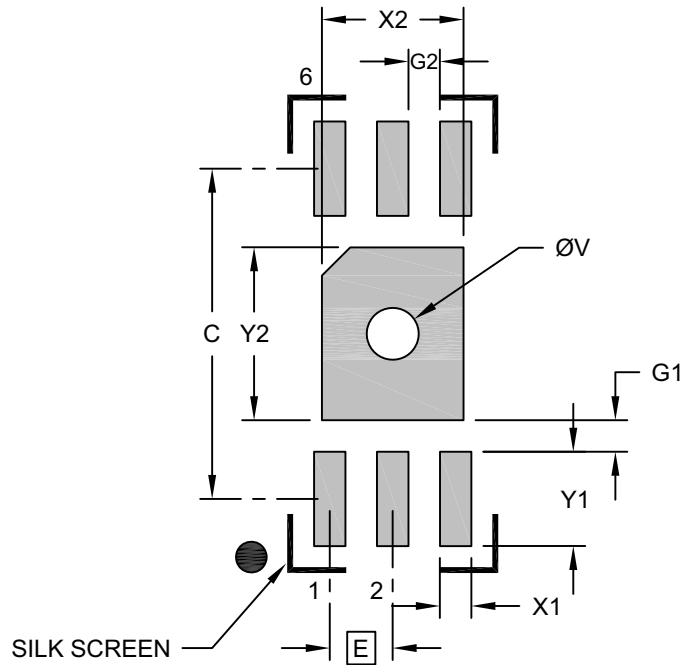

RECOMMENDED LAND PATTERN

		Units	MILLIMETERS		
Dimension Limits			MIN	NOM	MAX
Contact Pitch	E		0.40 BSC		
Optional Center Pad Width	X2				0.90
Optional Center Pad Length	Y2				1.10
Contact Pad Spacing	C		2.10		
Contact Pad Width (Xnn)	X1				0.20
Contact Pad Length (Xnn)	Y1				0.60
Contact Pad to Center Pad (Xnn)	G1		0.20		
Contact Pad to Contact Pad (Xnn)	G2		0.20		
Thermal Via Diameter	V		0.33		

Notes:

- Dimensioning and tolerancing per ASME Y14.5M
BSC: Basic Dimension. Theoretically exact value shown without tolerances.
- For best soldering results, thermal vias, if used, should be filled or tented to avoid solder loss during reflow process