

1 Mbit SPI Bus Serial EEPROM

Device Selection Table

Part Number	Vcc Range	Page Size	Temp. Ranges	Packages
25LC1024	2.5-5.5V	256 Byte	I,E	P, SM, MF

Features:

- 20 MHz max. Clock Speed
- Byte and Page-level Write Operations:
 - 256 byte page
 - 6 ms max. write cycle time
 - No page or sector erase required
- Low-Power CMOS Technology:
 - Max. Write current: 5 mA at 5.5V, 20 MHz
 - Read current: 7 mA at 5.5V, 20 MHz
 - Standby current: 1µA at 2.5V (Deep power-down)
- Electronic Signature for Device ID
- Self-Timed Erase and Write Cycles:
 - Page Erase (6 ms max.)
 - Sector Erase (10 ms max.)
 - Chip Erase (10 ms max.)
- Sector Write Protection (32K byte/sector):
 - Protect none, 1/4, 1/2 or all of array
- Built-In Write Protection:
 - Power-on/off data protection circuitry
 - Write enable latch
 - Write-protect pin
- High Reliability:
 - Endurance: 1M erase/write cycles
 - Data Retention: >200 years
 - ESD Protection: >4000V
- Temperature Ranges Supported:
 - Industrial (I): -40°C to +85°C
 - Automotive (E): -40°C to +125°C
- Pb-Free and RoHS Compliant

Description:

The Microchip Technology Inc. 25LC1024 is a 1024 Kbit serial EEPROM memory with byte-level and page-level serial EEPROM functions. It also features Page, Sector and Chip erase functions typically associated with Flash-based products. These functions are not required for byte or page write operations. The memory is accessed via a simple Serial Peripheral Interface (SPI) compatible serial bus. The bus signals required are a clock input (SCK) plus separate data in (SI) and data out (SO) lines. Access to the device is controlled by a Chip Select (CS) input.

Communication to the device can be paused via the hold pin ($\overline{\text{HOLD}}$). While the device is paused, transitions on its inputs will be ignored, with the exception of Chip Select, allowing the host to service higher priority interrupts.

The 25LC1024 is available in standard packages including 8-lead PDIP and SOIJ, and advanced 8-lead DFN package. All devices are Pb-free.

Package Types (not to scale)

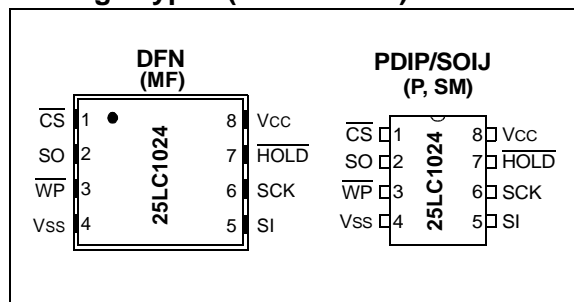

25LC1024

1.0 ELECTRICAL CHARACTERISTICS

Absolute Maximum Ratings (†)

V _{CC}	6.5V
All inputs and outputs w.r.t. V _{SS}	-0.6V to V _{CC} +1.0V
Storage temperature	-65°C to 150°C
Ambient temperature under bias.....	-40°C to 125°C
ESD protection on all pins.....	4 kV

† NOTICE: Stresses above those listed under “Absolute Maximum Ratings” may cause permanent damage to the device. This is a stress rating only and functional operation of the device at those or any other conditions above those indicated in the operational listings of this specification is not implied. Exposure to maximum rating conditions for an extended period of time may affect device reliability.

TABLE 1-1: DC CHARACTERISTICS

DC CHARACTERISTICS			Industrial (I):	TA = -40°C to +85°C	V _{CC} = 2.5V to 5.5V	
			Automotive (E):	TA = -40°C to +125°C	V _{CC} = 2.5V to 5.5V	
Param. No.	Sym.	Characteristic	Min.	Max.	Units	Test Conditions
D001	V _{IH1}	High-level input voltage	.7 V _{CC}	V _{CC} +1	V	
D002	V _{IL1}	Low-level input voltage	-0.3	0.3 V _{CC}	V	V _{CC} ≥ 2.7V
D003	V _{IL2}		-0.3	0.2 V _{CC}	V	V _{CC} < 2.7V
D004	V _{OL}	Low-level output voltage	—	0.4	V	I _{OL} = 2.1 mA
D005	V _{OH}	High-level output voltage	V _{CC} -0.2	—	V	I _{OH} = -400 μA
D006	I _{LI}	Input leakage current	—	±1	μA	\overline{CS} = V _{CC} , V _{IN} = V _{SS} or V _{CC}
D007	I _{LO}	Output leakage current	—	±1	μA	\overline{CS} = V _{CC} , V _{OUT} = V _{SS} or V _{CC}
D008	C _{INT}	Internal capacitance (all inputs and outputs)	—	7	pF	TA = 25°C, CLK = 1.0 MHz, V _{CC} = 5.0V (Note)
D009	I _{CC} Read	Operating current	—	10	mA	V _{CC} = 5.5V; F _{CLK} = 20.0 MHz; SO = Open
D010	I _{CC} Write		—	5	mA	V _{CC} = 2.5V; F _{CLK} = 10.0 MHz; SO = Open
D011	I _{CCS}	Standby current	—	20	μA	\overline{CS} = V _{CC} = 5.5V, Inputs tied to V _{CC} or V _{SS} , 125°C
			—	12	μA	\overline{CS} = V _{CC} = 5.5V, Inputs tied to V _{CC} or V _{SS} , 85°C
D012	I _{CCSPD}	Deep power-down current	—	1	μA	\overline{CS} = V _{CC} = 2.5V, Inputs tied to V _{CC} or V _{SS} , 85°C
			—	2	μA	\overline{CS} = V _{CC} = 2.5V, Inputs tied to V _{CC} or V _{SS} , 125°C

Note: This parameter is periodically sampled and not 100% tested.

TABLE 1-2: AC CHARACTERISTICS

AC CHARACTERISTICS			Industrial (I): TA = -40°C to +85°C		VCC = 2.5V to 5.5V	
			Automotive (E): TA = -40°C to +125°C		VCC = 2.5V to 5.5V	
Param. No.	Sym.	Characteristic	Min.	Max.	Units	Conditions
1	FCLK	Clock frequency	—	20	MHz	4.5V ≤ VCC ≤ 5.5V (I)
			—	10	MHz	2.5V ≤ VCC < 5.5V (I, E)
2	TCSS	$\overline{\text{CS}}$ setup time	25	—	ns	4.5V ≤ VCC ≤ 5.5V (I)
			50	—	ns	2.5V ≤ VCC < 5.5V (I, E)
3	TCSH	$\overline{\text{CS}}$ hold time	50	—	ns	4.5V ≤ VCC ≤ 5.5V (I)
			100	—	ns	2.5V ≤ VCC < 5.5V (I, E)
4	TCSD	$\overline{\text{CS}}$ disable time	50	—	ns	—
5	Tsu	Data setup time	5	—	ns	4.5V ≤ VCC ≤ 5.5V (I)
			10	—	ns	2.5V ≤ VCC < 5.5V (I, E)
6	THD	Data hold time	10	—	ns	4.5V ≤ VCC ≤ 5.5V (I)
			20	—	ns	2.5V ≤ VCC < 5.5V (I, E)
7	TR	CLK rise time	—	20	ns	(Note 1)
8	TF	CLK fall time	—	20	ns	(Note 1)
9	THI	Clock high time	25	—	ns	4.5V ≤ VCC ≤ 5.5V (I)
			50	—	ns	2.5V ≤ VCC < 5.5V (I, E)
10	TLO	Clock low time	25	—	ns	4.5V ≤ VCC ≤ 5.5V (I)
			50	—	ns	2.5V ≤ VCC < 5.5V (I, E)
11	TCLD	Clock delay time	50	—	ns	—
12	TCLE	Clock enable time	50	—	ns	—
13	TV	Output valid from clock low	—	25	ns	4.5V ≤ VCC ≤ 5.5V (I)
			—	50	ns	2.5V ≤ VCC < 5.5V (I, E)
14	THO	Output hold time	0	—	ns	(Note 1)
15	TDIS	Output disable time	—	25	ns	4.5V ≤ VCC ≤ 5.5V (I)
			—	50	ns	2.5V ≤ VCC < 5.5V (I, E)
16	THS	$\overline{\text{HOLD}}$ setup time	10	—	ns	4.5V ≤ VCC ≤ 5.5V (I)
			20	—	ns	2.5V ≤ VCC < 5.5V (I, E)
17	THH	$\overline{\text{HOLD}}$ hold time	10	—	ns	4.5V ≤ VCC ≤ 5.5V (I)
			20	—	ns	2.5V ≤ VCC < 5.5V (I, E)
18	THZ	$\overline{\text{HOLD}}$ low to output High-Z	15	—	ns	4.5V ≤ VCC ≤ 5.5V (I)
			30	—	ns	2.5V ≤ VCC < 5.5V (I, E)
19	THV	$\overline{\text{HOLD}}$ high to output valid	15	—	ns	4.5V ≤ VCC ≤ 5.5V (I)
			30	—	ns	2.5V ≤ VCC < 5.5V (I, E)
20	TREL	$\overline{\text{CS}}$ High to Standby mode	—	100	μs	—
21	TPD	$\overline{\text{CS}}$ High to Deep power-down	—	100	μs	—
22	TCE	Chip erase cycle time	—	10	ms	—
23	TSE	Sector erase cycle time	—	10	ms	—
24	TWC	Internal write cycle time	—	6	ms	Byte or Page mode and Page Erase

Note 1: This parameter is periodically sampled and not 100% tested.

2: This parameter is not tested but established by characterization and qualification. For endurance estimates in a specific application, please consult the Total Endurance™ Model which can be obtained from Microchip's web site

25LC1024

TABLE 1-2: AC CHARACTERISTICS (CONTINUED)

AC CHARACTERISTICS			Industrial (I): TA = -40°C to +85°C		VCC = 2.5V to 5.5V	
			Automotive (E): TA = -40°C to +125°C		VCC = 2.5V to 5.5V	
Param. No.	Sym.	Characteristic	Min.	Max.	Units	Conditions
25	—	Endurance	1M	—	E/W Cycles	(Note 2) Per Page

Note 1: This parameter is periodically sampled and not 100% tested.

2: This parameter is not tested but established by characterization and qualification. For endurance estimates in a specific application, please consult the Total Endurance™ Model which can be obtained from Microchip's web site

TABLE 1-3: AC TEST CONDITIONS

AC Waveform:	
VLO = 0.2V	—
VHI = VCC - 0.2V	(Note 1)
VHI = 4.0V	(Note 2)
CL = 30 pF	—
Timing Measurement Reference Level	
Input	0.5 VCC
Output	0.5 VCC

Note 1: For VCC ≤ 4.0V

2: For VCC > 4.0V

8-Lead Plastic Dual Flat, No Lead Package (MF) – 6x5 mm Body [DFN-S]

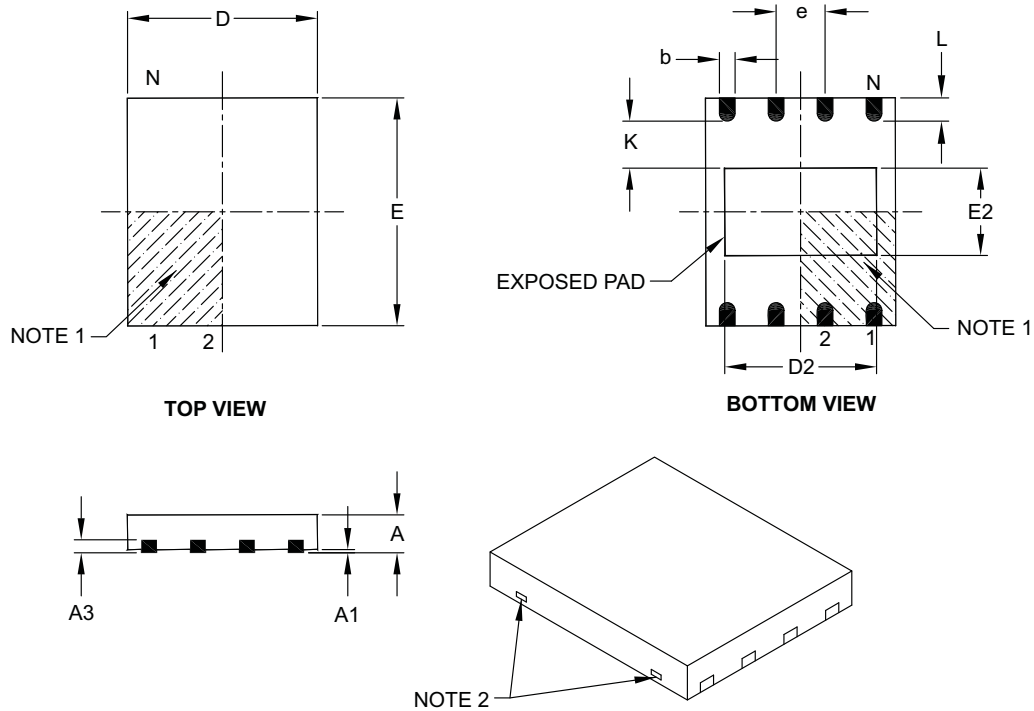

Dimension Limits	Units	MILLIMETERS		
		MIN	NOM	MAX
Number of Pins	N	8		
Pitch	e	1.27 BSC		
Overall Height	A	0.80	0.85	1.00
Standoff	A1	0.00	0.01	0.05
Contact Thickness	A3	0.20 REF		
Overall Length	D	5.00 BSC		
Overall Width	E	6.00 BSC		
Exposed Pad Length	D2	3.90	4.00	4.10
Exposed Pad Width	E2	2.20	2.30	2.40
Contact Width	b	0.35	0.40	0.48
Contact Length	L	0.50	0.60	0.75
Contact-to-Exposed Pad	K	0.20	-	-

Notes:

- Pin 1 visual index feature may vary, but must be located within the hatched area.
- Package may have one or more exposed tie bars at ends.
- Package is saw singulated.
- Dimensioning and tolerancing per ASME Y14.5M.

BSC: Basic Dimension. Theoretically exact value shown without tolerances.

REF: Reference Dimension, usually without tolerance, for information purposes only.

Microchip Technology Drawing C04-122B

25LC1024

8-Lead Plastic Dual Flat, No Lead Package (MF) - 6x5 mm Body [DFN-S]

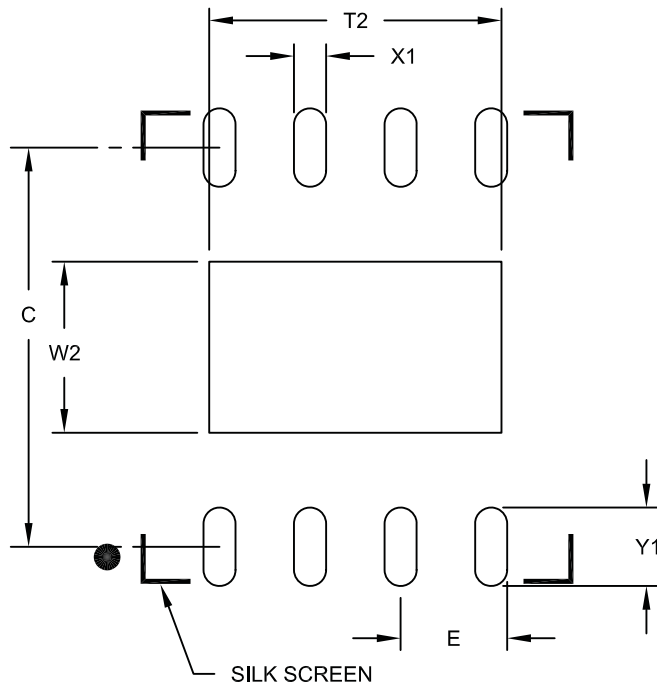

RECOMMENDED LAND PATTERN

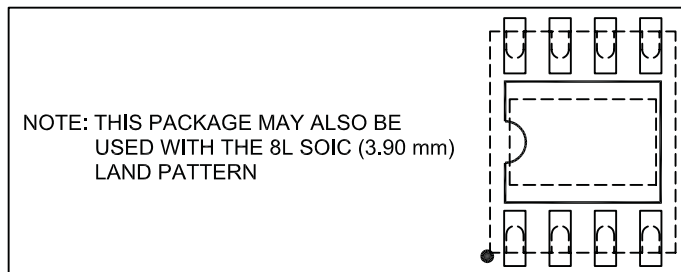

Dimension Limits	Units	MILLIMETERS		
		MIN	NOM	MAX
Contact Pitch	E	1.27 BSC		
Optional Center Pad Width	W2			2.40
Optional Center Pad Length	T2			4.10
Contact Pad Spacing	C		5.60	
Contact Pad Width (X8)	X1			0.45
Contact Pad Length (X8)	Y1			1.10

Notes:

1. Dimensioning and tolerancing per ASME Y14.5M

BSC: Basic Dimension. Theoretically exact value shown without tolerances.

Microchip Technology Drawing No. C04-2122A

PRODUCT IDENTIFICATION SYSTEM

To order or obtain information, e.g., on pricing or delivery, refer to the factory or the listed sales office.

<u>PART NO.</u>	X	-	X	/XX
Device	Tape & Reel		Temp Range	Package
Device:	25LC1024		1 Mbit, 2.5V, SPI Serial EEPROM	
Tape & Reel:	Blank =		Standard packaging (tube)	
	T =		Tape & Reel	
Temperature Range:	I =		-40°C to+85°C	
	E =		-40°C to+125°C	
Package:	MF =		Micro Lead Frame (6 x 5 mm body), 8-lead	
	P =		Plastic DIP (300 mil body), 8-lead	
	SM =		Plastic SOIJ (5.28 mm), 8-lead	

Examples:

- a) 25LC1024-I/P = 1 Mbit, 2.5V Serial EEPROM, Industrial temp., P-DIP package
- b) 25LC1024T-E/MF = 1 Mbit, 2.5V Serial EEPROM, Extended temp., Tape & Reel, DFN package