

MC79L00 SERIES NEGATIVE-VOLTAGE REGULATORS

SLVS011D – OCTOBER 1982 – REVISED AUGUST 2003

- 3-Terminal Regulators
- Output Current Up To 100 mA
- No External Components Required
- Internal Thermal-Overload Protection
- Internal Short-Circuit Current Limiting
- Direct Replacement for Industry-Standard MC79L00 Series
- Available in 5% or 10% Selections

**D PACKAGE
(TOP VIEW)**

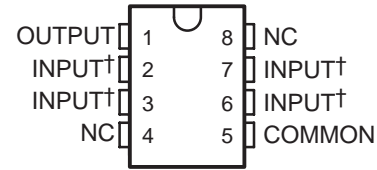

† Internally connected
NC – No internal connection

description/ordering information

This series of fixed negative-voltage integrated-circuit voltage regulators is designed for a wide range of applications. These include on-card regulation for elimination of noise and distribution problems associated with single-point regulation. In addition, they can be used to control series pass elements to make high-current voltage-regulator circuits. One of these regulators can deliver up to 100 mA of output current. The internal current-limiting and thermal-shutdown features essentially make the regulators immune to overload. When used as a replacement for a Zener-diode and resistor combination, these devices can provide an effective improvement in output impedance of two orders of magnitude, with lower bias current.

**LP PACKAGE
(TOP VIEW)**



ORDERING INFORMATION

T _J	OUTPUT VOLTAGE TOLERANCE	NOMINAL OUTPUT VOLTAGE (V)	PACKAGE†		ORDERABLE PART NUMBER	TOP-SIDE MARKING
0°C to 125°C	5%	-5	SOIC (D)	Tube of 75	MC79L05ACD	79L05A
				Reel of 2500	MC79L05ACDR	
			TO-226 / TO-92 (LP)	Bulk of 1000	MC79L05ACL	79L05AC
		Reel of 2000		MC79L05ACLPR		
		-12	SOIC (D)	Tube of 75	MC79L12ACD	79L12A
				Reel of 2500	MC79L12ACDR	
	TO-226 / TO-92 (LP)		Bulk of 1000	MC79L12ACL	79L12AC	
		Reel of 2000	MC79L12ACLPR			
	-15	TO-226 / TO-92 (LP)	Bulk of 1000	MC79L15ACL	79L15AC	
			Ammo of 2000	MC79L15ACLPM		
			Reel of 2000	MC79L15ACLPR		
	10%	-12	TO-226 / TO-92 (LP)	Bulk of 1000	MC79L12CLP	79L12C
-15		SOIC (D)	Tube of 75	MC79L15CD	79L15C	

† Package drawings, standard packing quantities, thermal data, symbolization, and PCB design guidelines are available at www.ti.com/sc/package.



Please be aware that an important notice concerning availability, standard warranty, and use in critical applications of Texas Instruments semiconductor products and disclaimers thereto appears at the end of this data sheet.

PRODUCTION DATA information is current as of publication date. Products conform to specifications per the terms of Texas Instruments standard warranty. Production processing does not necessarily include testing of all parameters.

**TEXAS
INSTRUMENTS**

POST OFFICE BOX 655303 • DALLAS, TEXAS 75265

Copyright © 2003, Texas Instruments Incorporated

MC79L00 SERIES NEGATIVE-VOLTAGE REGULATORS

SLVS011D – OCTOBER 1982 – REVISED AUGUST 2003

equivalent schematic

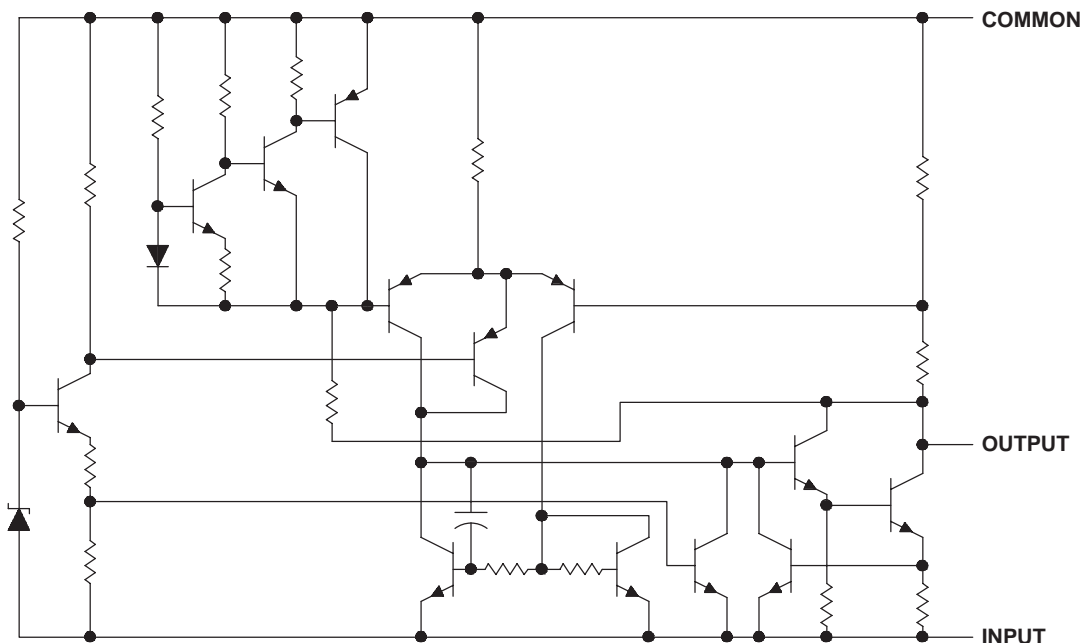

absolute maximum ratings over operating free-air temperature range (unless otherwise noted)[†]

Input voltage: MC79L05	-30 V
MC79L12, MC79L15	-35 V
Package thermal impedance, θ_{JA} (see Notes 1 and 2): D package	97°C/W
LP package	140°C/W
Operating free-air, case, or virtual junction temperature	150°C
Lead temperature 1.6 mm (1/16 inch) from case for 10 seconds	260°C
Storage temperature range, T_{stg}	-65°C to 150°C

[†] Stresses beyond those listed under “absolute maximum ratings” may cause permanent damage to the device. These are stress ratings only, and functional operation of the device at these or any other conditions beyond those indicated under “recommended operating conditions” is not implied. Exposure to absolute-maximum-rated conditions for extended periods may affect device reliability.

- NOTES: 1. Maximum power dissipation is a function of $T_J(\max)$, θ_{JA} , and T_A . The maximum allowable power dissipation at any allowable ambient temperature is $P_D = (T_J(\max) - T_A)/\theta_{JA}$. Operating at the absolute maximum T_J of 150°C can affect reliability.
2. The package thermal impedance is calculated in accordance with JESD 51-7.

recommended operating conditions

		MIN	MAX	UNIT	
V_I	Input voltage	MC79L05	-7	-20	V
		MC79L12	-14.5	-27	
		MC79L15	-17.5	-30	
I_O	Output current		100	mA	
T_J	Operating virtual junction temperature	0	125	°C	



POST OFFICE BOX 655303 • DALLAS, TEXAS 75265

MC79L00 SERIES NEGATIVE-VOLTAGE REGULATORS

SLVS011D – OCTOBER 1982 – REVISED AUGUST 2003

electrical characteristics at specified virtual junction temperature, $V_I = -10\text{ V}$, $I_O = 40\text{ mA}$ (unless otherwise noted)

PARAMETER	TEST CONDITION [†]	T _J	MC79L05C			MC79L05AC			UNIT
			MIN	TYP	MAX	MIN	TYP	MAX	
Output voltage [‡]		25°C	-4.6	-5	-5.4	-4.8	-5	-5.2	V
	$V_I = -7\text{ V to }-20\text{ V}$, $I_O = 1\text{ mA to }40\text{ mA}$	0°C to 125°C	-4.5		-5.5	-4.75		-5.25	
	$V_I = -10\text{ V}$, $I_O = 1\text{ mA to }70\text{ mA}$	0°C to 125°C	-4.5		-5.5	-4.75		-5.25	
Input regulation	$V_I = -7\text{ V to }-20\text{ V}$	25°C			200			150	mV
	$V_I = -8\text{ V to }-20\text{ V}$				150			100	
Ripple rejection	$V_I = -8\text{ V to }-18\text{ V}$, $f = 120\text{ Hz}$	25°C	40	49		41	49		dB
Output regulation	$I_O = 1\text{ mA to }100\text{ mA}$	25°C			60			60	mV
	$I_O = 1\text{ mA to }40\text{ mA}$				30			30	
Output noise voltage	$f = 10\text{ Hz to }100\text{ kHz}$	25°C		40		40			μV
Dropout voltage	$I_O = 40\text{ mA}$	25°C		1.7		1.7			V
Bias current		25°C			6			6	mA
		125°C			5.5			5.5	
Bias current change	$V_I = -8\text{ V to }-20\text{ V}$	0°C to 125°C			1.5			1.5	mA
	$I_O = 1\text{ mA to }40\text{ mA}$				0.2			0.1	

[†] All characteristics are measured with a 0.33-μF capacitor across the input and a 0.1-μF capacitor across the output. Pulse-testing techniques are used to maintain the junction temperature as close to the ambient temperature as possible. Thermal effects must be taken into account separately.

[‡] This specification applies only for dc power dissipation permitted by absolute maximum ratings.

electrical characteristics at specified virtual junction temperature, $V_I = -19\text{ V}$, $I_O = 40\text{ mA}$ (unless otherwise noted)

PARAMETER	TEST CONDITION [†]	T _J	MC79L12C			MC79L12AC			UNIT
			MIN	TYP	MAX	MIN	TYP	MAX	
Output voltage [‡]		25°C	-11.1	-12	-12.9	-11.5	-12	-12.5	V
	$V_I = -14.5\text{ V to }-27\text{ V}$, $I_O = 1\text{ mA to }40\text{ mA}$	0°C to 125°C	-10.8		-13.2	-11.4		-12.6	
	$V_I = -19\text{ V}$, $I_O = 1\text{ mA to }70\text{ mA}$	0°C to 125°C	-10.8		-13.2	-11.4		-12.6	
Input regulation	$V_I = -14.5\text{ V to }-27\text{ V}$	25°C			250			250	mV
	$V_I = -16\text{ V to }-27\text{ V}$				200			200	
Ripple rejection	$V_I = -15\text{ V to }-25\text{ V}$, $f = 120\text{ Hz}$	25°C	36	42		37	42		dB
Output regulation	$I_O = 1\text{ mA to }100\text{ mA}$	25°C			100			100	mV
	$I_O = 1\text{ mA to }40\text{ mA}$				50			50	
Output noise voltage	$f = 10\text{ Hz to }100\text{ kHz}$	25°C		80		80			μV
Dropout voltage	$I_O = 40\text{ mA}$	25°C		1.7		1.7			V
Bias current		25°C			6.5			6.5	mA
		125°C			6			6	
Bias current change	$V_I = -16\text{ V to }-27\text{ V}$	0°C to 125°C			1.5			1.5	mA
	$I_O = 1\text{ mA to }40\text{ mA}$				0.2			0.1	

[†] All characteristics are measured with a 0.33-μF capacitor across the input and a 0.1-μF capacitor across the output. Pulse-testing techniques are used to maintain the junction temperature as close to the ambient temperature as possible. Thermal effects must be taken into account separately.

[‡] This specification applies only for dc power dissipation permitted by absolute maximum ratings.



MC79L00 SERIES NEGATIVE-VOLTAGE REGULATORS

SLVS011D – OCTOBER 1982 – REVISED AUGUST 2003

electrical characteristics at specified virtual junction temperature, $V_I = -23\text{ V}$, $I_O = 40\text{ mA}$ (unless otherwise noted)

PARAMETER	TEST CONDITION†	T _J	MC79L15C			MC79L15AC			UNIT
			MIN	TYP	MAX	MIN	TYP	MAX	
Output voltage‡		25°C	-13.8	-15	-16.2	-14.4	-15	-15.6	V
	$V_I = -17.5\text{ V to }-30\text{ V}$, $I_O = 1\text{ mA to }40\text{ mA}$	0°C to 125°C	-13.5		-16.5	-14.25		-15.75	
	$V_I = -23\text{ V}$, $I_O = 1\text{ mA to }70\text{ mA}$	0°C to 125°C	-13.5		-16.5	-14.25		-15.75	
Input regulation	$V_I = -17.5\text{ V to }-30\text{ V}$	25°C	300			300			mV
	$V_I = -17.5\text{ V to }-30\text{ V}$		250			250			
Ripple rejection	$V_I = -18.5\text{ V to }-28.5\text{ V}$, $f = 120\text{ Hz}$	25°C	33	39		34	39		dB
Output regulation	$I_O = 1\text{ mA to }100\text{ mA}$	25°C	150			150			mV
	$I_O = 1\text{ mA to }40\text{ mA}$		75			75			
Output noise voltage	$f = 10\text{ Hz to }100\text{ kHz}$	25°C	90			90			μV
Dropout voltage	$I_O = 40\text{ mA}$	25°C	1.7			1.7			V
Bias current		25°C	6.5			6.5			mA
		125°C	6			6			
Bias current change	$V_I = -20\text{ V to }-30\text{ V}$	0°C to 125°C	1.5			1.5			mA
	$I_O = 1\text{ mA to }40\text{ mA}$		0.2			0.1			

† All characteristics are measured with a 0.33-μF capacitor across the input and a 0.1-μF capacitor across the output. Pulse-testing techniques are used to maintain the junction temperature as close to the ambient temperature as possible. Thermal effects must be taken into account separately.

‡ This specification applies only for dc power dissipation permitted by absolute maximum ratings.



PACKAGING INFORMATION

Orderable Device	Status (1)	Package Type	Package Drawing	Pins	Package Qty	Eco Plan (2)	Lead/Ball Finish (6)	MSL Peak Temp (3)	Op Temp (°C)	Device Marking (4/5)	Samples
MC79L05ACD	ACTIVE	SOIC	D	8	75	Green (RoHS & no Sb/Br)	CU NIPDAU	Level-1-260C-UNLIM	0 to 125	79L05A	Samples
MC79L05ACDE4	ACTIVE	SOIC	D	8	75	Green (RoHS & no Sb/Br)	CU NIPDAU	Level-1-260C-UNLIM	0 to 125	79L05A	Samples
MC79L05ACDG4	ACTIVE	SOIC	D	8	75	Green (RoHS & no Sb/Br)	CU NIPDAU	Level-1-260C-UNLIM	0 to 125	79L05A	Samples
MC79L05ACDR	ACTIVE	SOIC	D	8	2500	Green (RoHS & no Sb/Br)	CU NIPDAU	Level-1-260C-UNLIM	0 to 125	79L05A	Samples
MC79L05ACDRE4	ACTIVE	SOIC	D	8	2500	Green (RoHS & no Sb/Br)	CU NIPDAU	Level-1-260C-UNLIM	0 to 125	79L05A	Samples
MC79L05ACDRG4	ACTIVE	SOIC	D	8	2500	Green (RoHS & no Sb/Br)	CU NIPDAU	Level-1-260C-UNLIM	0 to 125	79L05A	Samples
MC79L05ACLP	ACTIVE	TO-92	LP	3	1000	Pb-Free (RoHS)	CU SN	N / A for Pkg Type	0 to 125	79L05AC	Samples
MC79L05ACLPE3	ACTIVE	TO-92	LP	3	1000	Pb-Free (RoHS)	CU SN	N / A for Pkg Type	0 to 125	79L05AC	Samples
MC79L05ACLPR	ACTIVE	TO-92	LP	3	2000	Pb-Free (RoHS)	CU SN	N / A for Pkg Type	0 to 125	79L05AC	Samples
MC79L05ACLPRE3	ACTIVE	TO-92	LP	3	2000	Pb-Free (RoHS)	CU SN	N / A for Pkg Type	0 to 125	79L05AC	Samples
MC79L05AILP	OBSOLETE	TO-92	LP	3		TBD	Call TI	Call TI	0 to 125		
MC79L05CD	OBSOLETE	SOIC	D	8		TBD	Call TI	Call TI	0 to 125		
MC79L05CDR	OBSOLETE	SOIC	D	8		TBD	Call TI	Call TI	0 to 125		
MC79L05CLP	OBSOLETE	TO-92	LP	3		TBD	Call TI	Call TI	0 to 125		
MC79L12ACD	ACTIVE	SOIC	D	8	75	Green (RoHS & no Sb/Br)	CU NIPDAU	Level-1-260C-UNLIM	0 to 125	79L12A	Samples
MC79L12ACDE4	ACTIVE	SOIC	D	8	75	Green (RoHS & no Sb/Br)	CU NIPDAU	Level-1-260C-UNLIM	0 to 125	79L12A	Samples
MC79L12ACDG4	ACTIVE	SOIC	D	8	75	Green (RoHS & no Sb/Br)	CU NIPDAU	Level-1-260C-UNLIM	0 to 125	79L12A	Samples
MC79L12ACDR	ACTIVE	SOIC	D	8	2500	Green (RoHS & no Sb/Br)	CU NIPDAU	Level-1-260C-UNLIM	0 to 125	79L12A	Samples
MC79L12ACDRE4	ACTIVE	SOIC	D	8	2500	Green (RoHS & no Sb/Br)	CU NIPDAU	Level-1-260C-UNLIM	0 to 125	79L12A	Samples

Orderable Device	Status (1)	Package Type	Package Drawing	Pins	Package Qty	Eco Plan (2)	Lead/Ball Finish (6)	MSL Peak Temp (3)	Op Temp (°C)	Device Marking (4/5)	Samples
MC79L12ACDRG4	ACTIVE	SOIC	D	8		TBD	Call TI	Call TI	0 to 125		Samples
MC79L12ACLP	ACTIVE	TO-92	LP	3	1000	Pb-Free (RoHS)	CU SN	N / A for Pkg Type	0 to 125	79L12AC	Samples
MC79L12ACLPE3	ACTIVE	TO-92	LP	3	1000	Pb-Free (RoHS)	CU SN	N / A for Pkg Type	0 to 125	79L12AC	Samples
MC79L12ACLPR	ACTIVE	TO-92	LP	3	2000	Pb-Free (RoHS)	CU SN	N / A for Pkg Type	0 to 125	79L12AC	Samples
MC79L12ACLPRE3	ACTIVE	TO-92	LP	3	2000	Pb-Free (RoHS)	CU SN	N / A for Pkg Type	0 to 125	79L12AC	Samples
MC79L12CD	OBSOLETE	SOIC	D	8		TBD	Call TI	Call TI	0 to 125		
MC79L12CLP	ACTIVE	TO-92	LP	3	1000	Pb-Free (RoHS)	CU SN	N / A for Pkg Type	0 to 125	79L12C	Samples
MC79L12CLPE3	ACTIVE	TO-92	LP	3		TBD	Call TI	Call TI	0 to 125		Samples
MC79L15ACD	OBSOLETE	SOIC	D	8		TBD	Call TI	Call TI	0 to 125		
MC79L15ACLP	ACTIVE	TO-92	LP	3	1000	Pb-Free (RoHS)	CU SN	N / A for Pkg Type	0 to 125	79L15AC	Samples
MC79L15ACLPE3	ACTIVE	TO-92	LP	3	1000	Pb-Free (RoHS)	CU SN	N / A for Pkg Type	0 to 125	79L15AC	Samples
MC79L15ACLPR	ACTIVE	TO-92	LP	3	2000	Pb-Free (RoHS)	CU SN	N / A for Pkg Type	0 to 125	79L15AC	Samples
MC79L15ACLPRE3	ACTIVE	TO-92	LP	3	2000	Pb-Free (RoHS)	CU SN	N / A for Pkg Type	0 to 125	79L15AC	Samples
MC79L15CLP	OBSOLETE	TO-92	LP	3		TBD	Call TI	Call TI			

(1) The marketing status values are defined as follows:

ACTIVE: Product device recommended for new designs.

LIFEBUY: TI has announced that the device will be discontinued, and a lifetime-buy period is in effect.

NRND: Not recommended for new designs. Device is in production to support existing customers, but TI does not recommend using this part in a new design.

PREVIEW: Device has been announced but is not in production. Samples may or may not be available.

OBSOLETE: TI has discontinued the production of the device.

(2) Eco Plan - The planned eco-friendly classification: Pb-Free (RoHS), Pb-Free (RoHS Exempt), or Green (RoHS & no Sb/Br) - please check <http://www.ti.com/productcontent> for the latest availability information and additional product content details.

TBD: The Pb-Free/Green conversion plan has not been defined.

Pb-Free (RoHS): TI's terms "Lead-Free" or "Pb-Free" mean semiconductor products that are compatible with the current RoHS requirements for all 6 substances, including the requirement that lead not exceed 0.1% by weight in homogeneous materials. Where designed to be soldered at high temperatures, TI Pb-Free products are suitable for use in specified lead-free processes.

Pb-Free (RoHS Exempt): This component has a RoHS exemption for either 1) lead-based flip-chip solder bumps used between the die and package, or 2) lead-based die adhesive used between the die and leadframe. The component is otherwise considered Pb-Free (RoHS compatible) as defined above.

Green (RoHS & no Sb/Br): TI defines "Green" to mean Pb-Free (RoHS compatible), and free of Bromine (Br) and Antimony (Sb) based flame retardants (Br or Sb do not exceed 0.1% by weight in homogeneous material)

⁽³⁾ MSL, Peak Temp. - The Moisture Sensitivity Level rating according to the JEDEC industry standard classifications, and peak solder temperature.

⁽⁴⁾ There may be additional marking, which relates to the logo, the lot trace code information, or the environmental category on the device.

⁽⁵⁾ Multiple Device Markings will be inside parentheses. Only one Device Marking contained in parentheses and separated by a "~" will appear on a device. If a line is indented then it is a continuation of the previous line and the two combined represent the entire Device Marking for that device.

⁽⁶⁾ Lead/Ball Finish - Orderable Devices may have multiple material finish options. Finish options are separated by a vertical ruled line. Lead/Ball Finish values may wrap to two lines if the finish value exceeds the maximum column width.

Important Information and Disclaimer:The information provided on this page represents TI's knowledge and belief as of the date that it is provided. TI bases its knowledge and belief on information provided by third parties, and makes no representation or warranty as to the accuracy of such information. Efforts are underway to better integrate information from third parties. TI has taken and continues to take reasonable steps to provide representative and accurate information but may not have conducted destructive testing or chemical analysis on incoming materials and chemicals. TI and TI suppliers consider certain information to be proprietary, and thus CAS numbers and other limited information may not be available for release.

In no event shall TI's liability arising out of such information exceed the total purchase price of the TI part(s) at issue in this document sold by TI to Customer on an annual basis.

TAPE AND REEL INFORMATION



QUADRANT ASSIGNMENTS FOR PIN 1 ORIENTATION IN TAPE



*All dimensions are nominal

Device	Package Type	Package Drawing	Pins	SPQ	Reel Diameter (mm)	Reel Width W1 (mm)	A0 (mm)	B0 (mm)	K0 (mm)	P1 (mm)	W (mm)	Pin1 Quadrant
MC79L05ACDR	SOIC	D	8	2500	330.0	12.4	6.4	5.2	2.1	8.0	12.0	Q1
MC79L12ACDR	SOIC	D	8	2500	330.0	12.4	6.4	5.2	2.1	8.0	12.0	Q1

TAPE AND REEL BOX DIMENSIONS



*All dimensions are nominal

Device	Package Type	Package Drawing	Pins	SPQ	Length (mm)	Width (mm)	Height (mm)
MC79L05ACDR	SOIC	D	8	2500	340.5	338.1	20.6
MC79L12ACDR	SOIC	D	8	2500	340.5	338.1	20.6

D (R-PDSO-G8)

PLASTIC SMALL OUTLINE

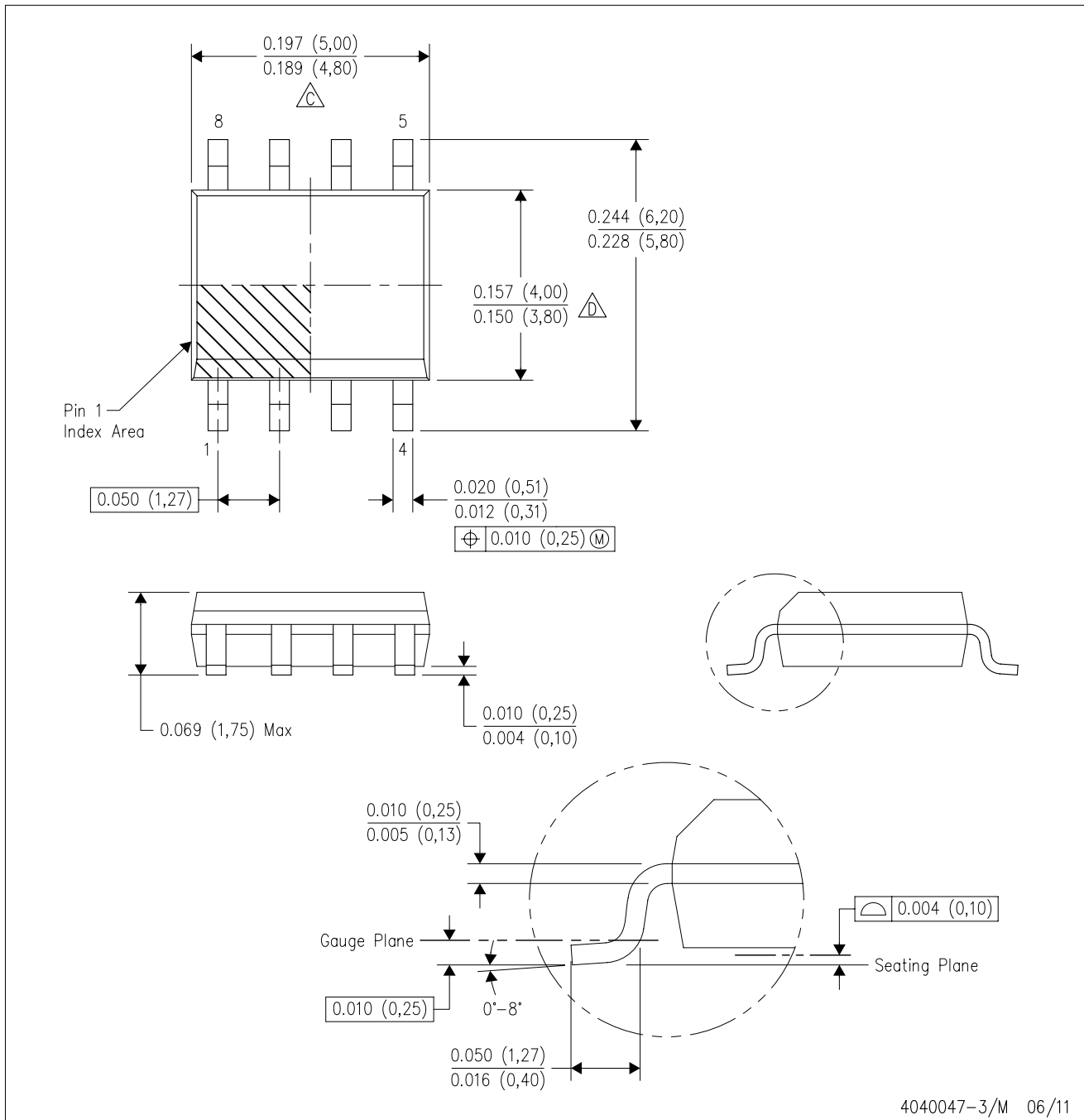

- NOTES:
- A. All linear dimensions are in inches (millimeters).
 - B. This drawing is subject to change without notice.
 - C. Body length does not include mold flash, protrusions, or gate burrs. Mold flash, protrusions, or gate burrs shall not exceed 0.006 (0,15) each side.
 - D. Body width does not include interlead flash. Interlead flash shall not exceed 0.017 (0,43) each side.
 - E. Reference JEDEC MS-012 variation AA.

D (R-PDSO-G8)

PLASTIC SMALL OUTLINE

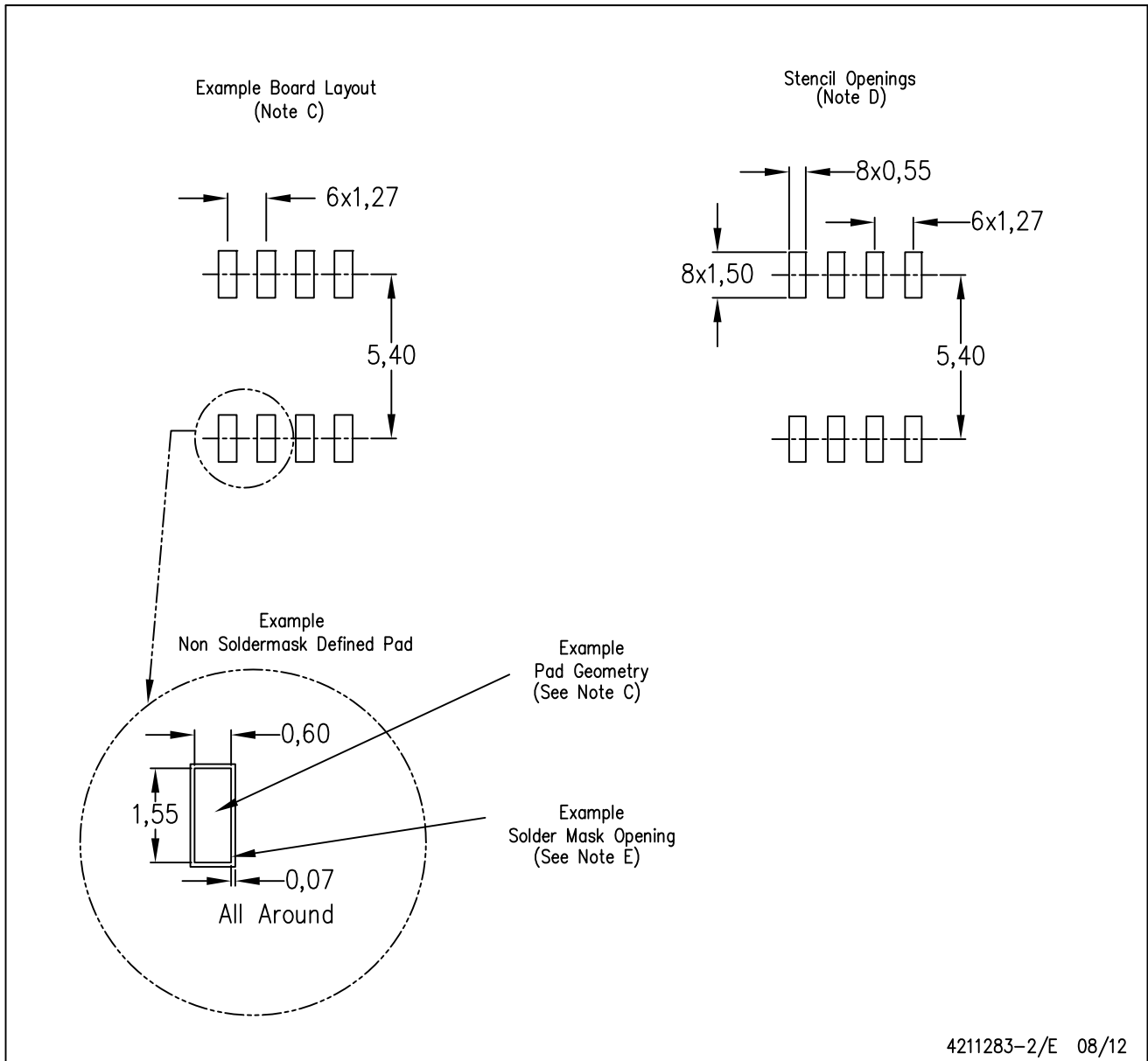

- NOTES:
- All linear dimensions are in millimeters.
 - This drawing is subject to change without notice.
 - Publication IPC-7351 is recommended for alternate designs.
 - Laser cutting apertures with trapezoidal walls and also rounding corners will offer better paste release. Customers should contact their board assembly site for stencil design recommendations. Refer to IPC-7525 for other stencil recommendations.
 - Customers should contact their board fabrication site for solder mask tolerances between and around signal pads.

LP (O-PBCY-W3)

PLASTIC CYLINDRICAL PACKAGE

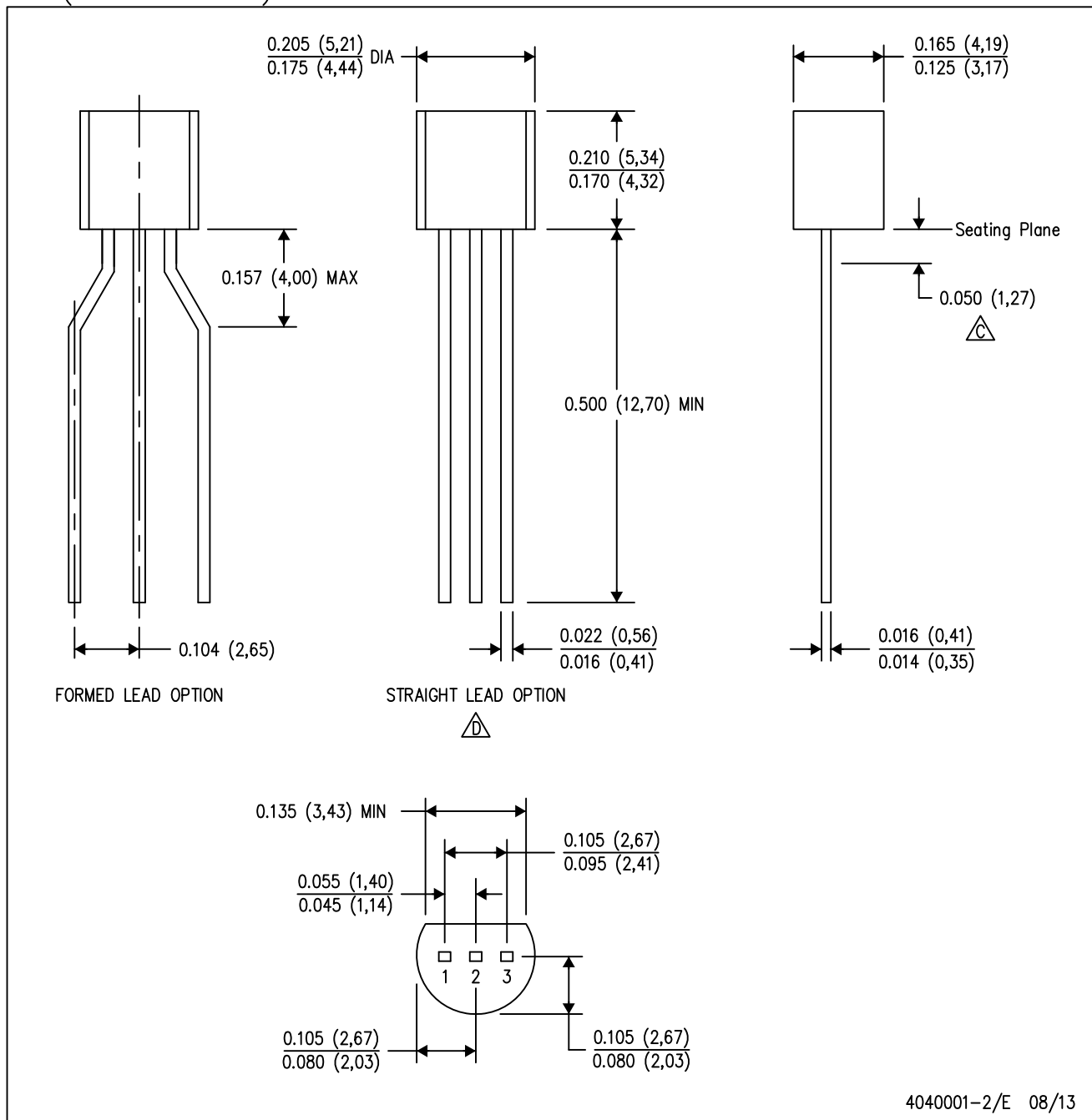

4040001-2/E 08/13

MECHANICAL DATA

LP (O-PBCY-W3)

PLASTIC CYLINDRICAL PACKAGE

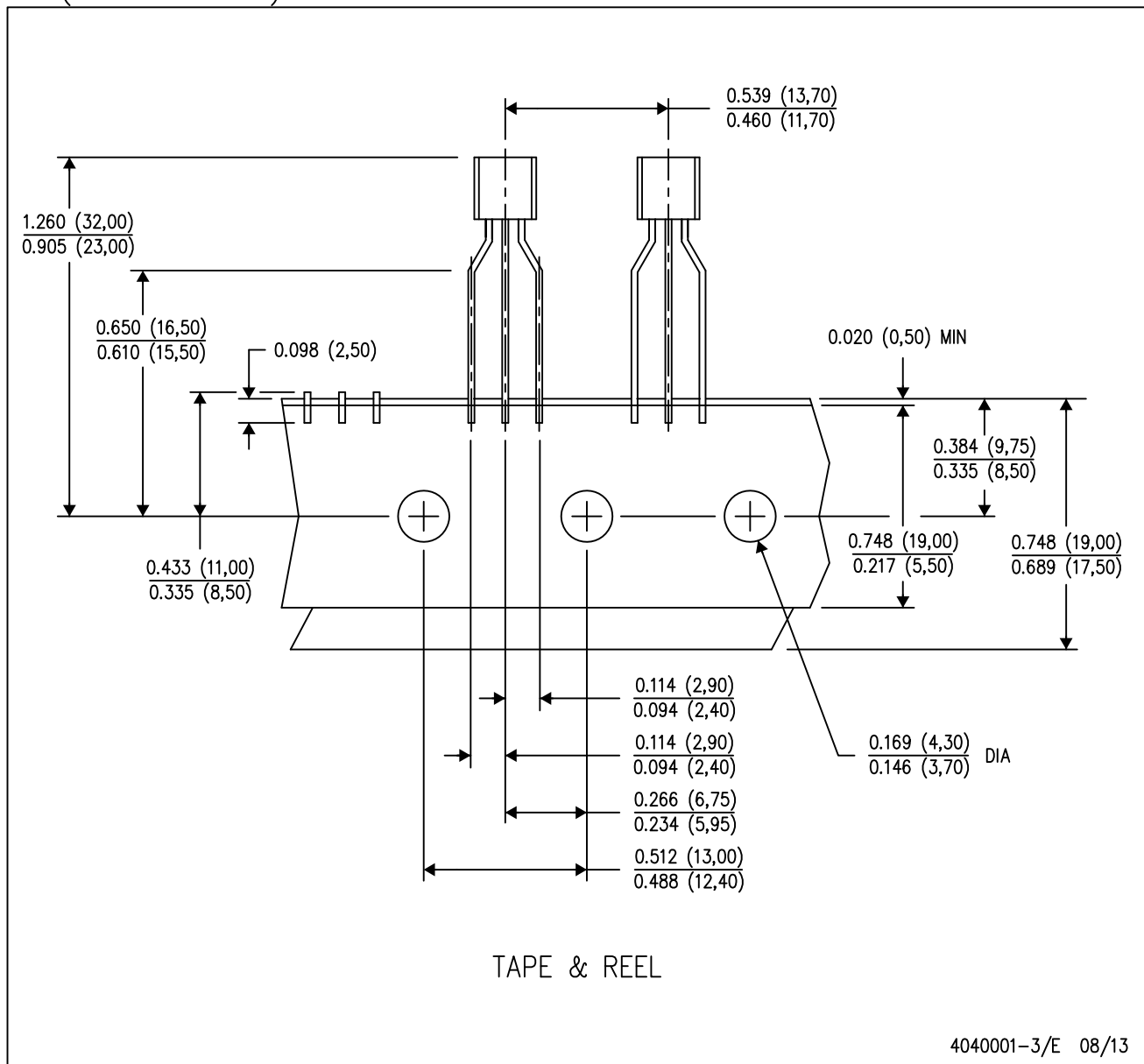

- NOTES:
- A. All linear dimensions are in inches (millimeters).
 - B. This drawing is subject to change without notice.
 - C. Tape and Reel information for the Formed Lead Option package.

IMPORTANT NOTICE

Texas Instruments Incorporated and its subsidiaries (TI) reserve the right to make corrections, enhancements, improvements and other changes to its semiconductor products and services per JESD46, latest issue, and to discontinue any product or service per JESD48, latest issue. Buyers should obtain the latest relevant information before placing orders and should verify that such information is current and complete. All semiconductor products (also referred to herein as "components") are sold subject to TI's terms and conditions of sale supplied at the time of order acknowledgment.

TI warrants performance of its components to the specifications applicable at the time of sale, in accordance with the warranty in TI's terms and conditions of sale of semiconductor products. Testing and other quality control techniques are used to the extent TI deems necessary to support this warranty. Except where mandated by applicable law, testing of all parameters of each component is not necessarily performed.

TI assumes no liability for applications assistance or the design of Buyers' products. Buyers are responsible for their products and applications using TI components. To minimize the risks associated with Buyers' products and applications, Buyers should provide adequate design and operating safeguards.

TI does not warrant or represent that any license, either express or implied, is granted under any patent right, copyright, mask work right, or other intellectual property right relating to any combination, machine, or process in which TI components or services are used. Information published by TI regarding third-party products or services does not constitute a license to use such products or services or a warranty or endorsement thereof. Use of such information may require a license from a third party under the patents or other intellectual property of the third party, or a license from TI under the patents or other intellectual property of TI.

Reproduction of significant portions of TI information in TI data books or data sheets is permissible only if reproduction is without alteration and is accompanied by all associated warranties, conditions, limitations, and notices. TI is not responsible or liable for such altered documentation. Information of third parties may be subject to additional restrictions.

Resale of TI components or services with statements different from or beyond the parameters stated by TI for that component or service voids all express and any implied warranties for the associated TI component or service and is an unfair and deceptive business practice. TI is not responsible or liable for any such statements.

Buyer acknowledges and agrees that it is solely responsible for compliance with all legal, regulatory and safety-related requirements concerning its products, and any use of TI components in its applications, notwithstanding any applications-related information or support that may be provided by TI. Buyer represents and agrees that it has all the necessary expertise to create and implement safeguards which anticipate dangerous consequences of failures, monitor failures and their consequences, lessen the likelihood of failures that might cause harm and take appropriate remedial actions. Buyer will fully indemnify TI and its representatives against any damages arising out of the use of any TI components in safety-critical applications.

In some cases, TI components may be promoted specifically to facilitate safety-related applications. With such components, TI's goal is to help enable customers to design and create their own end-product solutions that meet applicable functional safety standards and requirements. Nonetheless, such components are subject to these terms.

No TI components are authorized for use in FDA Class III (or similar life-critical medical equipment) unless authorized officers of the parties have executed a special agreement specifically governing such use.

Only those TI components which TI has specifically designated as military grade or "enhanced plastic" are designed and intended for use in military/aerospace applications or environments. Buyer acknowledges and agrees that any military or aerospace use of TI components which have **not** been so designated is solely at the Buyer's risk, and that Buyer is solely responsible for compliance with all legal and regulatory requirements in connection with such use.

TI has specifically designated certain components as meeting ISO/TS16949 requirements, mainly for automotive use. In any case of use of non-designated products, TI will not be responsible for any failure to meet ISO/TS16949.

Products

Audio	www.ti.com/audio
Amplifiers	amplifier.ti.com
Data Converters	dataconverter.ti.com
DLP® Products	www.dlp.com
DSP	dsp.ti.com
Clocks and Timers	www.ti.com/clocks
Interface	interface.ti.com
Logic	logic.ti.com
Power Mgmt	power.ti.com
Microcontrollers	microcontroller.ti.com
RFID	www.ti-rfid.com
OMAP Applications Processors	www.ti.com/omap
Wireless Connectivity	www.ti.com/wirelessconnectivity

Applications

Automotive and Transportation	www.ti.com/automotive
Communications and Telecom	www.ti.com/communications
Computers and Peripherals	www.ti.com/computers
Consumer Electronics	www.ti.com/consumer-apps
Energy and Lighting	www.ti.com/energy
Industrial	www.ti.com/industrial
Medical	www.ti.com/medical
Security	www.ti.com/security
Space, Avionics and Defense	www.ti.com/space-avionics-defense
Video and Imaging	www.ti.com/video

TI E2E Community

e2e.ti.com