

MC3486 QUADRUPLE DIFFERENTIAL LINE RECEIVER WITH 3-STATE OUTPUTS

SLLS097C – JUNE 1980 – REVISED FEBRUARY 2002

- Meets or Exceeds the Requirements of ANSI Standards EIA/TIA-422-B and EIA/TIA-423-B and ITU Recommendations V.10 and V.11
- 3-State, TTL-Compatible Outputs
- Fast Transition Times
- Operates From Single 5-V Supply
- Designed to Be Interchangeable With Motorola™ MC3486

D, N, OR NS PACKAGE
(TOP VIEW)

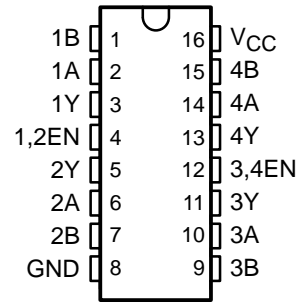

description

The MC3486 is a monolithic quadruple differential line receiver designed to meet the specifications of ANSI Standards TIA/EIA-422-B and TIA/EIA-423-B and ITU Recommendations V.10 and V.11. The MC3486 offers four independent differential-input line receivers that have TTL-compatible outputs. The outputs utilize 3-state circuitry to provide a high-impedance state at any output when the appropriate output enable is at a low logic level.

The MC3486 is designed for optimum performance when used with the MC3487 quadruple differential line driver. It is supplied in a 16-pin package and operates from a single 5-V supply.

The MC3486 is characterized for operation from 0°C to 70°C.

AVAILABLE OPTIONS

T _A	PACKAGED DEVICES	
	PLASTIC SMALL OUTLINE (D, NS)	PLASTIC DIP (N)
0°C to 70°C	MC3486D MC3486NS	MC3486N

The D package is available taped and reeled. Add the suffix R to the device type (e.g., MC3486DR). The NS package is only available taped and reeled.



Please be aware that an important notice concerning availability, standard warranty, and use in critical applications of Texas Instruments semiconductor products and disclaimers thereto appears at the end of this data sheet.

Motorola is a trademark of Motorola, Incorporated.

PRODUCTION DATA information is current as of publication date. Products conform to specifications per the terms of Texas Instruments standard warranty. Production processing does not necessarily include testing of all parameters.



POST OFFICE BOX 655303 • DALLAS, TEXAS 75265

Copyright © 2002, Texas Instruments Incorporated

MC3486 QUADRUPLE DIFFERENTIAL LINE RECEIVER WITH 3-STATE OUTPUTS

SLLS097C – JUNE 1980 – REVISED FEBRUARY 2002

FUNCTION TABLE
(each receiver)

DIFFERENTIAL INPUTS A-B	ENABLE	OUTPUT Y
$V_{ID} \leq 0.2\text{ V}$	H	H
$-0.2\text{ V} < V_{ID} < 0.2\text{ V}$	H	?
$V_{ID} \leq -0.2\text{ V}$	H	L
Irrelevant	L	Z
Open	H	?

H = high level, L = low level, Z = high impedance (off),
? = indeterminate

logic diagram (positive logic)

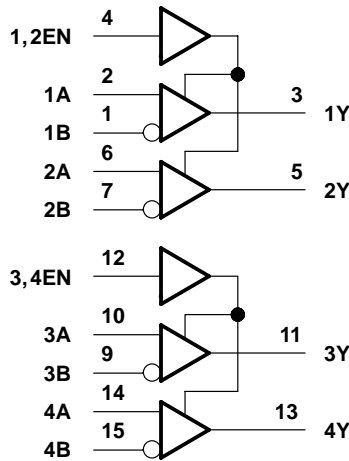

schematics of inputs and outputs

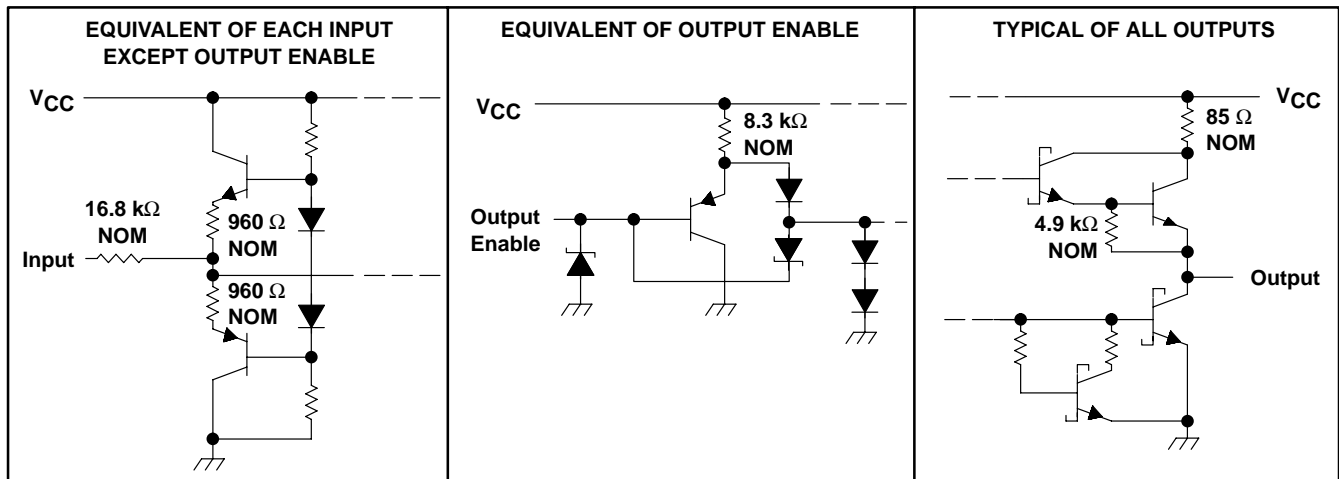

MC3486 QUADRUPLE DIFFERENTIAL LINE RECEIVER WITH 3-STATE OUTPUTS

SLLS097C – JUNE 1980 – REVISED FEBRUARY 2002

absolute maximum ratings over operating free-air temperature range (unless otherwise noted)†

Supply voltage, V_{CC} (see Note 1)	8 V
Input voltage, V_I (A or B inputs)	± 15 V
Differential input voltage, V_{ID} (see Note 2)	± 25 V
Enable input voltage	8 V
Low-level output current, I_{OL}	50 mA
Package thermal impedance, θ_{JA} (see Note 3): D package	73°C/W
N package	67°C/W
NS package	67°C/W
Lead temperature 1,6 mm (1/16 inch) from case for 10 seconds	260°C
Storage temperature range, T_{stg}	–65°C to 150°C

† Stresses beyond those listed under “absolute maximum ratings” may cause permanent damage to the device. These are stress ratings only, and functional operation of the device at these or any other conditions beyond those indicated under “recommended operating conditions” is not implied. Exposure to absolute-maximum-rated conditions for extended periods may affect device reliability.

- NOTES: 1. All voltage values, except differential-input voltage, are with respect to network ground terminal.
 2. Differential-input voltage is measured at the noninverting input with respect to the corresponding inverting input.
 3. The package thermal impedance is calculated in accordance with JESD 51-7.

recommended operating conditions

	MIN	NOM	MAX	UNIT
V_{CC} Supply voltage	4.75	5	5.25	V
V_{IC} Common-mode input voltage			± 7	V
V_{ID} Differential input voltage			± 6	V
V_{IH} High-level enable input voltage	2			V
V_{IL} Low-level enable input voltage			0.8	V
T_A Operating free-air temperature	0		70	°C



MC3486

QUADRUPLE DIFFERENTIAL LINE RECEIVER WITH 3-STATE OUTPUTS

SLLS097C – JUNE 1980 – REVISED FEBRUARY 2002

electrical characteristics over recommended ranges of common-mode input voltage, supply voltage, and operating free-air temperature (unless otherwise noted)

PARAMETER		TEST CONDITIONS	MIN	MAX	UNIT
V_{IT+}	Differential input high-threshold voltage	$V_O = 2.7\text{ V}$, $I_O = -0.4\text{ mA}$		0.2	V
V_{IT-}	Differential input low-threshold voltage	$V_O = 0.5\text{ V}$, $I_O = -8\text{ mA}$	-0.2^\dagger		V
V_{IK}	Enable-input clamp voltage	$I_I = -10\text{ mA}$		-1.5	V
V_{OH}	High-level output voltage	$V_{ID} = 0.4\text{ V}$, $I_O = -0.4\text{ mA}$, See Note 4 and Figure 1	2.7		V
V_{OL}	Low-level output voltage	$V_{ID} = -0.4\text{ V}$, $I_O = 8\text{ mA}$, See Note 4 and Figure 1		0.5	V
I_{OZ}	High-impedance-state output current	$V_{IL} = 0.8\text{ V}$, $V_{ID} = -3\text{ V}$, $V_O = 2.7\text{ V}$		40	μA
		$V_{IL} = 0.8\text{ V}$, $V_{ID} = 3\text{ V}$, $V_O = 0.5\text{ V}$		-40	
I_{IB}	Differential-input bias current	$V_{CC} = 0\text{ V}$ or 5.25 V , Other inputs at 0 V	$V_I = -10\text{ V}$	-3.25	mA
			$V_I = -3\text{ V}$	-1.5	
			$V_I = 3\text{ V}$	1.5	
			$V_I = 10\text{ V}$	3.25	
I_{IH}	High-level enable input current	$V_I = 5.25\text{ V}$		100	μA
		$V_I = 2.7\text{ V}$		20	
I_{IL}	Low-level enable input current	$V_I = -0.5\text{ V}$		-100	μA
I_{OS}	Short-circuit output current	$V_{ID} = 3\text{ V}$, $V_O = 0$, See Note 5	-15	-100	mA
I_{CC}	Supply current	$V_{IL} = 0$		85	mA

† The algebraic convention, in which the least positive (most negative) limit is designated as minimum, is used in this data sheet for threshold voltages only.

NOTES: 4. Refer to ANSI Standards TIA/EIA-422-B and TIA/EIA-423-B for exact conditions.

5. Only one output should be shorted at a time.

switching characteristics, $V_{CC} = 5\text{ V}$, $C_L = 15\text{ pF}$, $T_A = 25^\circ\text{C}$

PARAMETER		TEST CONDITIONS	MIN	TYP	MAX	UNIT
t_{PHL}	Propagation delay time, high- to low-level output	See Figure 2		28	35	ns
t_{PLH}	Propagation delay time, low- to high-level output			27	30	ns
t_{pZH}	Output enable time to high level	See Figure 3		13	30	ns
t_{pZL}	Output enable time to low level			20	30	ns
t_{PHZ}	Output disable time from high level			26	35	ns
t_{PLZ}	Output disable time from low level			27	35	ns



MC3486 QUADRUPLE DIFFERENTIAL LINE RECEIVER WITH 3-STATE OUTPUTS

SLLS097C – JUNE 1980 – REVISED FEBRUARY 2002

PARAMETER MEASUREMENT INFORMATION

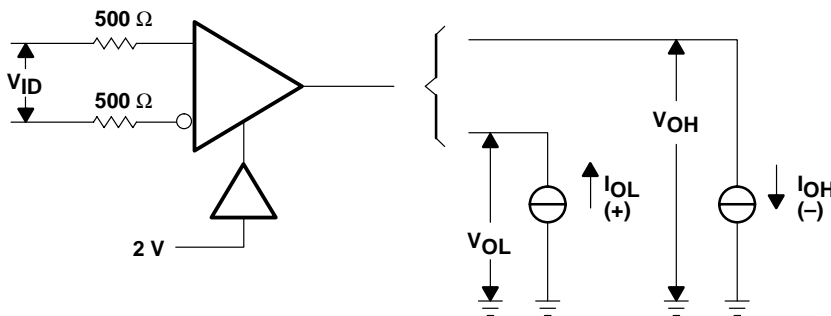
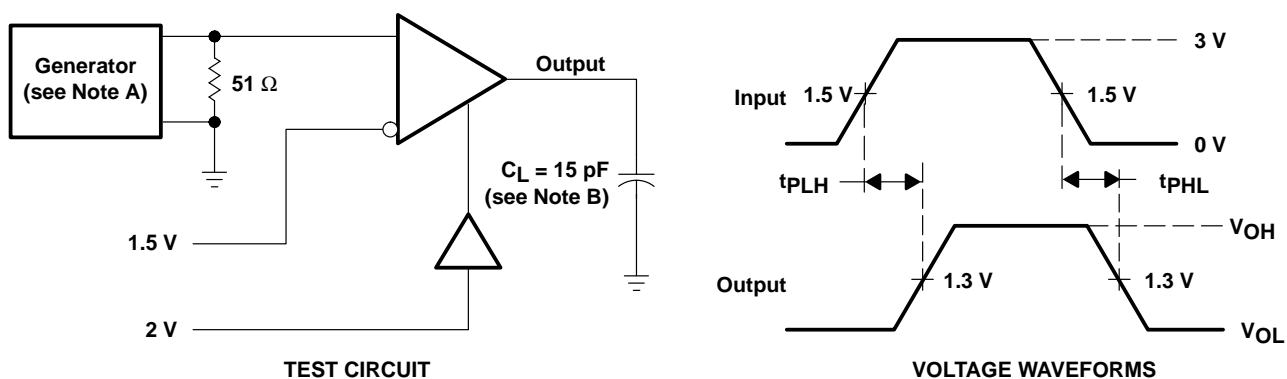

Figure 1. V_{OH} , V_{OL}



- NOTES: A. The input pulse is supplied by a generator having the following characteristics: $PRR \leq 1 \text{ MHz}$, duty cycle = 50%, $t_r \leq 6 \text{ ns}$, $t_f \leq 6 \text{ ns}$.
 B. C_L includes probe and stray capacitance.

Figure 2. Test Circuit and Voltage Waveforms

MC3486 QUADRUPLE DIFFERENTIAL LINE RECEIVER WITH 3-STATE OUTPUTS

SLLS097C – JUNE 1980 – REVISED FEBRUARY 2002

PARAMETER MEASUREMENT INFORMATION

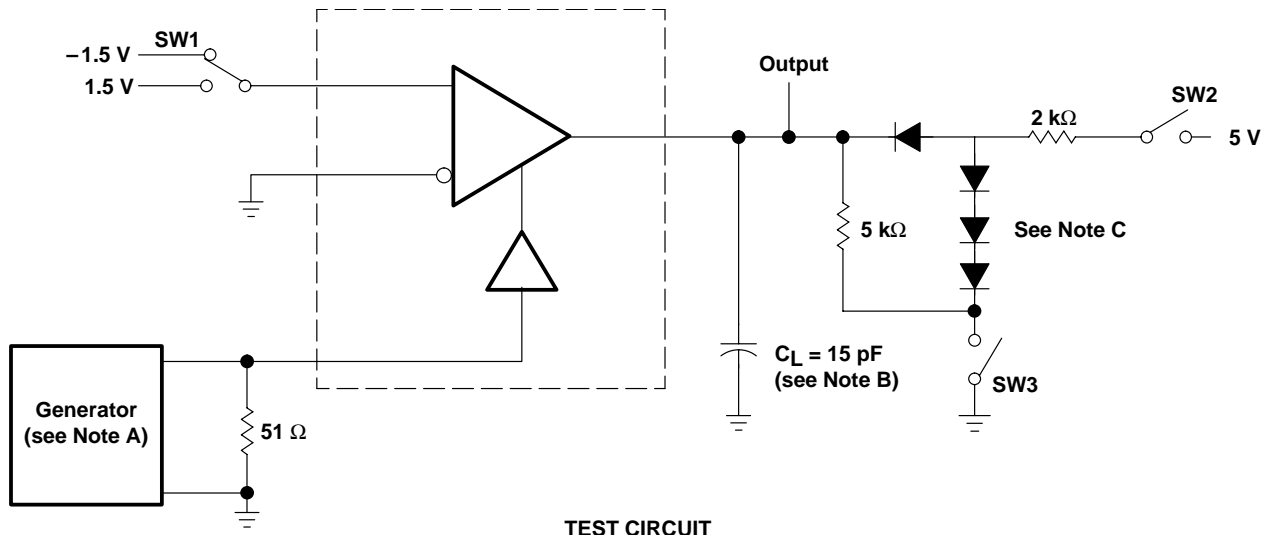

TEST CIRCUIT

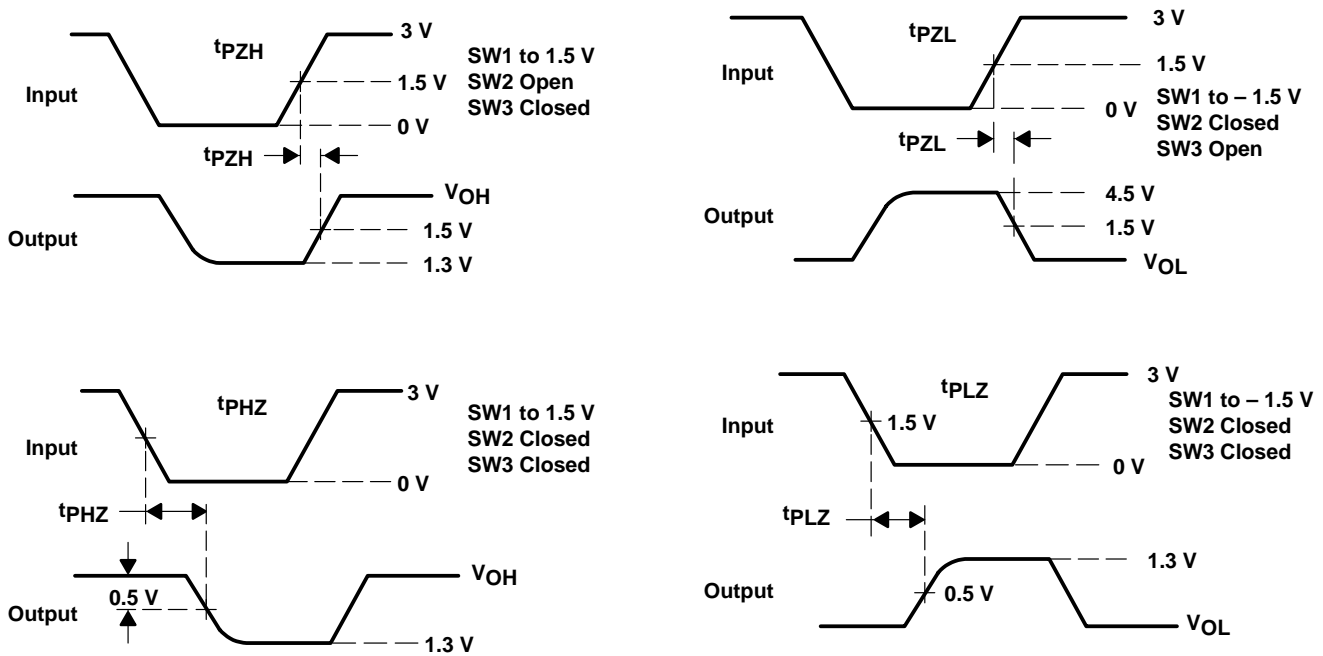

- NOTES: A. The input pulse is supplied by a generator having the following characteristics: PRR \leq 1 MHz, duty cycle = 50%, $t_r \leq$ 6 ns, $t_f \leq$ 6 ns.
 B. C_L includes probe and stray capacitance.
 C. All diodes are 1N916 or equivalent.

Figure 3. Test Circuit and Voltage Waveforms

PACKAGING INFORMATION

Orderable Device	Status ⁽¹⁾	Package Type	Package Drawing	Pins	Package Qty	Eco Plan ⁽²⁾	Lead/Ball Finish	MSL Peak Temp ⁽³⁾
MC3486D	ACTIVE	SOIC	D	16	40	Green (RoHS & no Sb/Br)	CU NIPDAU	Level-1-260C-UNLIM
MC3486DE4	ACTIVE	SOIC	D	16	40	Green (RoHS & no Sb/Br)	CU NIPDAU	Level-1-260C-UNLIM
MC3486DG4	ACTIVE	SOIC	D	16	40	Green (RoHS & no Sb/Br)	CU NIPDAU	Level-1-260C-UNLIM
MC3486DR	ACTIVE	SOIC	D	16	2500	Green (RoHS & no Sb/Br)	CU NIPDAU	Level-1-260C-UNLIM
MC3486DRE4	ACTIVE	SOIC	D	16	2500	Green (RoHS & no Sb/Br)	CU NIPDAU	Level-1-260C-UNLIM
MC3486DRG4	ACTIVE	SOIC	D	16	2500	Green (RoHS & no Sb/Br)	CU NIPDAU	Level-1-260C-UNLIM
MC3486J	OBSOLETE	CDIP	J	16		TBD	Call TI	Call TI
MC3486N	ACTIVE	PDIP	N	16	25	Pb-Free (RoHS)	CU NIPDAU	N / A for Pkg Type
MC3486NE4	ACTIVE	PDIP	N	16	25	Pb-Free (RoHS)	CU NIPDAU	N / A for Pkg Type
MC3486NSR	ACTIVE	SO	NS	16	2000	Green (RoHS & no Sb/Br)	CU NIPDAU	Level-1-260C-UNLIM
MC3486NSRE4	ACTIVE	SO	NS	16	2000	Green (RoHS & no Sb/Br)	CU NIPDAU	Level-1-260C-UNLIM
MC3486NSRG4	ACTIVE	SO	NS	16	2000	Green (RoHS & no Sb/Br)	CU NIPDAU	Level-1-260C-UNLIM

⁽¹⁾ The marketing status values are defined as follows:

ACTIVE: Product device recommended for new designs.

LIFEBUY: TI has announced that the device will be discontinued, and a lifetime-buy period is in effect.

NRND: Not recommended for new designs. Device is in production to support existing customers, but TI does not recommend using this part in a new design.

PREVIEW: Device has been announced but is not in production. Samples may or may not be available.

OBSOLETE: TI has discontinued the production of the device.

⁽²⁾ Eco Plan - The planned eco-friendly classification: Pb-Free (RoHS), Pb-Free (RoHS Exempt), or Green (RoHS & no Sb/Br) - please check <http://www.ti.com/productcontent> for the latest availability information and additional product content details.

TBD: The Pb-Free/Green conversion plan has not been defined.

Pb-Free (RoHS): TI's terms "Lead-Free" or "Pb-Free" mean semiconductor products that are compatible with the current RoHS requirements for all 6 substances, including the requirement that lead not exceed 0.1% by weight in homogeneous materials. Where designed to be soldered at high temperatures, TI Pb-Free products are suitable for use in specified lead-free processes.

Pb-Free (RoHS Exempt): This component has a RoHS exemption for either 1) lead-based flip-chip solder bumps used between the die and package, or 2) lead-based die adhesive used between the die and leadframe. The component is otherwise considered Pb-Free (RoHS compatible) as defined above.

Green (RoHS & no Sb/Br): TI defines "Green" to mean Pb-Free (RoHS compatible), and free of Bromine (Br) and Antimony (Sb) based flame retardants (Br or Sb do not exceed 0.1% by weight in homogeneous material)

⁽³⁾ MSL, Peak Temp. -- The Moisture Sensitivity Level rating according to the JEDEC industry standard classifications, and peak solder temperature.

Important Information and Disclaimer: The information provided on this page represents TI's knowledge and belief as of the date that it is provided. TI bases its knowledge and belief on information provided by third parties, and makes no representation or warranty as to the accuracy of such information. Efforts are underway to better integrate information from third parties. TI has taken and continues to take reasonable steps to provide representative and accurate information but may not have conducted destructive testing or chemical analysis on incoming materials and chemicals. TI and TI suppliers consider certain information to be proprietary, and thus CAS numbers and other limited information may not be available for release.

In no event shall TI's liability arising out of such information exceed the total purchase price of the TI part(s) at issue in this document sold by TI to Customer on an annual basis.

TAPE AND REEL INFORMATION
REEL DIMENSIONS

TAPE DIMENSIONS

A0	Dimension designed to accommodate the component width
B0	Dimension designed to accommodate the component length
K0	Dimension designed to accommodate the component thickness
W	Overall width of the carrier tape
P1	Pitch between successive cavity centers

TAPE AND REEL INFORMATION

*All dimensions are nominal

Device	Package Type	Package Drawing	Pins	SPQ	Reel Diameter (mm)	Reel Width W1 (mm)	A0 (mm)	B0 (mm)	K0 (mm)	P1 (mm)	W (mm)	Pin1 Quadrant
MC3486DR	SOIC	D	16	2500	330.0	16.4	6.5	10.3	2.1	8.0	16.0	Q1
MC3486NSR	SO	NS	16	2000	330.0	16.4	8.2	10.5	2.5	12.0	16.0	Q1

TAPE AND REEL BOX DIMENSIONS



*All dimensions are nominal

Device	Package Type	Package Drawing	Pins	SPQ	Length (mm)	Width (mm)	Height (mm)
MC3486DR	SOIC	D	16	2500	333.2	345.9	28.6
MC3486NSR	SO	NS	16	2000	367.0	367.0	38.0

J (R-GDIP-T**)

14 LEADS SHOWN

CERAMIC DUAL IN-LINE PACKAGE



DIM \ PINS **	14	16	18	20
A	0.300 (7,62) BSC	0.300 (7,62) BSC	0.300 (7,62) BSC	0.300 (7,62) BSC
B MAX	0.785 (19,94)	.840 (21,34)	0.960 (24,38)	1.060 (26,92)
B MIN	—	—	—	—
C MAX	0.300 (7,62)	0.300 (7,62)	0.310 (7,87)	0.300 (7,62)
C MIN	0.245 (6,22)	0.245 (6,22)	0.220 (5,59)	0.245 (6,22)



4040083/F 03/03

- NOTES:
- All linear dimensions are in inches (millimeters).
 - This drawing is subject to change without notice.
 - This package is hermetically sealed with a ceramic lid using glass frit.
 - Index point is provided on cap for terminal identification only on press ceramic glass frit seal only.
 - Falls within MIL STD 1835 GDIP1-T14, GDIP1-T16, GDIP1-T18 and GDIP1-T20.

N (R-PDIP-T**)

PLASTIC DUAL-IN-LINE PACKAGE

16 PINS SHOWN



- NOTES:
- A. All linear dimensions are in inches (millimeters).
 - B. This drawing is subject to change without notice.
 - Falls within JEDEC MS-001, except 18 and 20 pin minimum body length (Dim A).
 - The 20 pin end lead shoulder width is a vendor option, either half or full width.

D (R-PDSO-G16)

PLASTIC SMALL OUTLINE



- NOTES:
- A. All linear dimensions are in inches (millimeters).
 - B. This drawing is subject to change without notice.
 - C. Body length does not include mold flash, protrusions, or gate burrs. Mold flash, protrusions, or gate burrs shall not exceed 0.006 (0,15) each side.
 - D. Body width does not include interlead flash. Interlead flash shall not exceed 0.017 (0,43) each side.
 - E. Reference JEDEC MS-012 variation AC.

D (R-PDSO-G16)

PLASTIC SMALL OUTLINE

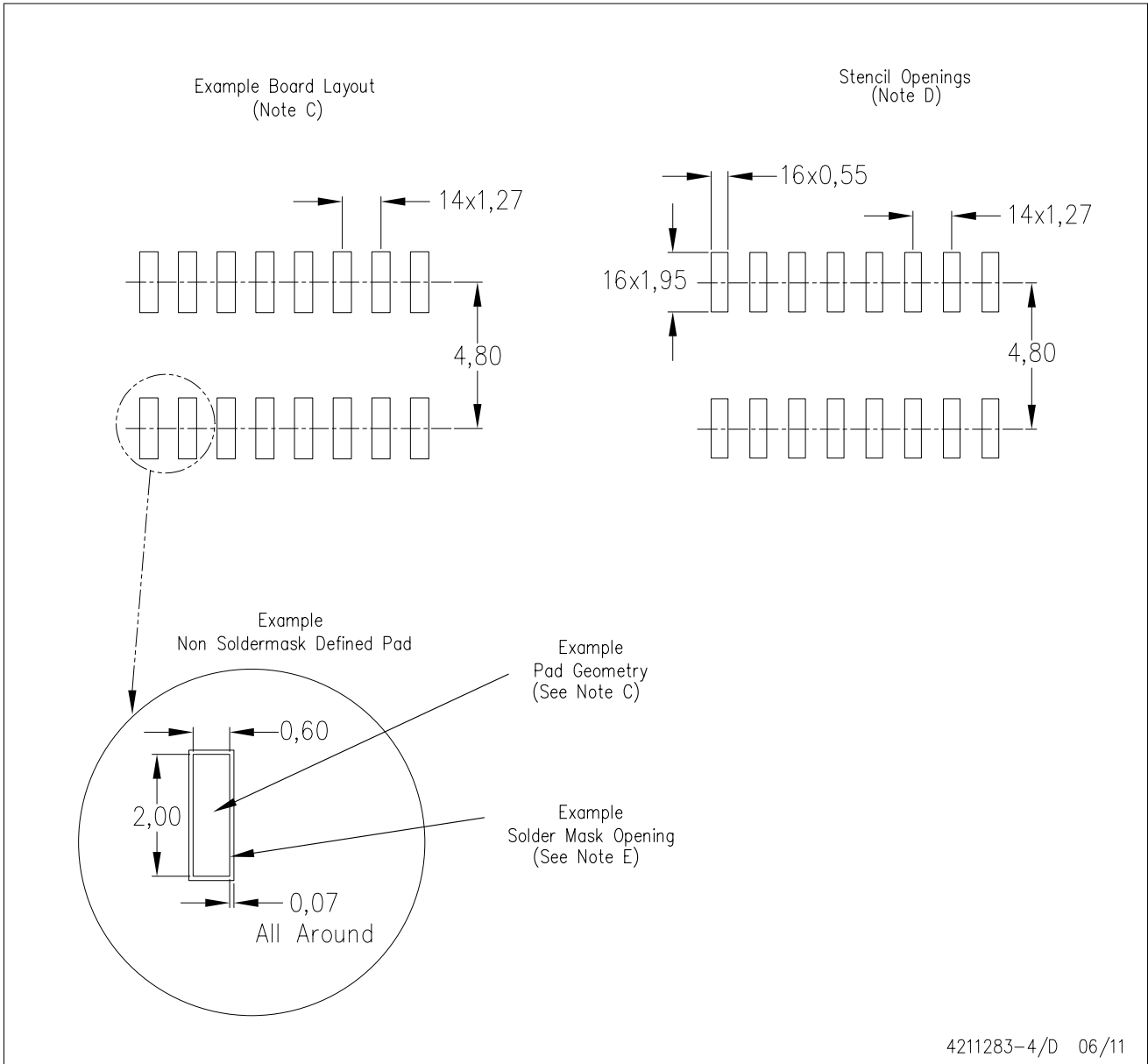

- NOTES:
- All linear dimensions are in millimeters.
 - This drawing is subject to change without notice.
 - Publication IPC-7351 is recommended for alternate designs.
 - Laser cutting apertures with trapezoidal walls and also rounding corners will offer better paste release. Customers should contact their board assembly site for stencil design recommendations. Refer to IPC-7525 for other stencil recommendations.
 - Customers should contact their board fabrication site for solder mask tolerances between and around signal pads.

MECHANICAL DATA

NS (R-PDSO-G)**

PLASTIC SMALL-OUTLINE PACKAGE

14-PINS SHOWN



- NOTES:
- A. All linear dimensions are in millimeters.
 - B. This drawing is subject to change without notice.
 - C. Body dimensions do not include mold flash or protrusion, not to exceed 0,15.

IMPORTANT NOTICE

Texas Instruments Incorporated and its subsidiaries (TI) reserve the right to make corrections, enhancements, improvements and other changes to its semiconductor products and services per JESD46C and to discontinue any product or service per JESD48B. Buyers should obtain the latest relevant information before placing orders and should verify that such information is current and complete. All semiconductor products (also referred to herein as "components") are sold subject to TI's terms and conditions of sale supplied at the time of order acknowledgment.

TI warrants performance of its components to the specifications applicable at the time of sale, in accordance with the warranty in TI's terms and conditions of sale of semiconductor products. Testing and other quality control techniques are used to the extent TI deems necessary to support this warranty. Except where mandated by applicable law, testing of all parameters of each component is not necessarily performed.

TI assumes no liability for applications assistance or the design of Buyers' products. Buyers are responsible for their products and applications using TI components. To minimize the risks associated with Buyers' products and applications, Buyers should provide adequate design and operating safeguards.

TI does not warrant or represent that any license, either express or implied, is granted under any patent right, copyright, mask work right, or other intellectual property right relating to any combination, machine, or process in which TI components or services are used. Information published by TI regarding third-party products or services does not constitute a license to use such products or services or a warranty or endorsement thereof. Use of such information may require a license from a third party under the patents or other intellectual property of the third party, or a license from TI under the patents or other intellectual property of TI.

Reproduction of significant portions of TI information in TI data books or data sheets is permissible only if reproduction is without alteration and is accompanied by all associated warranties, conditions, limitations, and notices. TI is not responsible or liable for such altered documentation. Information of third parties may be subject to additional restrictions.

Resale of TI components or services with statements different from or beyond the parameters stated by TI for that component or service voids all express and any implied warranties for the associated TI component or service and is an unfair and deceptive business practice. TI is not responsible or liable for any such statements.

Buyer acknowledges and agrees that it is solely responsible for compliance with all legal, regulatory and safety-related requirements concerning its products, and any use of TI components in its applications, notwithstanding any applications-related information or support that may be provided by TI. Buyer represents and agrees that it has all the necessary expertise to create and implement safeguards which anticipate dangerous consequences of failures, monitor failures and their consequences, lessen the likelihood of failures that might cause harm and take appropriate remedial actions. Buyer will fully indemnify TI and its representatives against any damages arising out of the use of any TI components in safety-critical applications.

In some cases, TI components may be promoted specifically to facilitate safety-related applications. With such components, TI's goal is to help enable customers to design and create their own end-product solutions that meet applicable functional safety standards and requirements. Nonetheless, such components are subject to these terms.

No TI components are authorized for use in FDA Class III (or similar life-critical medical equipment) unless authorized officers of the parties have executed a special agreement specifically governing such use.

Only those TI components which TI has specifically designated as military grade or "enhanced plastic" are designed and intended for use in military/aerospace applications or environments. Buyer acknowledges and agrees that any military or aerospace use of TI components which have **not** been so designated is solely at the Buyer's risk, and that Buyer is solely responsible for compliance with all legal and regulatory requirements in connection with such use.

TI has specifically designated certain components which meet ISO/TS16949 requirements, mainly for automotive use. Components which have not been so designated are neither designed nor intended for automotive use; and TI will not be responsible for any failure of such components to meet such requirements.

Products

Audio	www.ti.com/audio
Amplifiers	amplifier.ti.com
Data Converters	dataconverter.ti.com
DLP® Products	www.dlp.com
DSP	dsp.ti.com
Clocks and Timers	www.ti.com/clocks
Interface	interface.ti.com
Logic	logic.ti.com
Power Mgmt	power.ti.com
Microcontrollers	microcontroller.ti.com
RFID	www.ti-rfid.com
OMAP Mobile Processors	www.ti.com/omap
Wireless Connectivity	www.ti.com/wirelessconnectivity

Applications

Automotive and Transportation	www.ti.com/automotive
Communications and Telecom	www.ti.com/communications
Computers and Peripherals	www.ti.com/computers
Consumer Electronics	www.ti.com/consumer-apps
Energy and Lighting	www.ti.com/energy
Industrial	www.ti.com/industrial
Medical	www.ti.com/medical
Security	www.ti.com/security
Space, Avionics and Defense	www.ti.com/space-avionics-defense
Video and Imaging	www.ti.com/video

TI E2E Community e2e.ti.com