

## FEATURES

- ESD Protection for RS-232 I/O Pins
  - $\pm 15$  kV (Human-Body Model)
  - $\pm 8$  kV (IEC 61000-4-2, Contact Discharge)
  - $\pm 15$  kV (IEC 61000-4-2, Air-Gap Discharge)
- 300- $\mu$ A Operating Supply Current
- 1- $\mu$ A Low-Power Standby (With Receivers Active) Mode
- Designed to Transmit at a Data Rate of 460 kbps
- Auto-Power-Down Plus Option Features Flexible Power-Saving Mode
- Operates From a Single 2.25-V to 3-V  $V_{CC}$  Supply

## APPLICATIONS

- Battery-Powered Systems
- PDAs
- Cellular Phones
- Notebooks
- Hand-Held Equipment
- Pagers

## DESCRIPTION/ORDERING INFORMATION

The MAX3318E is a dual-driver, dual-receiver, RS-232-compatible transceiver. The device features auto-power-down plus and enhanced electrostatic discharge (ESD) protection integrated into the chip. Driver output and receiver input are protected to  $\pm 15$  kV using the IEC 61000-4-2 Air-Gap Discharge method,  $\pm 8$  kV using the IEC 61000-4-2 Contact Discharge method, and  $\pm 15$  kV using the Human-Body Model (HBM).

The device operates at a data rate of 460 kbps. The transceiver has a proprietary low-dropout driver output stage, enabling RS-232-compatible operation from a 2.25-V to 3-V supply with a dual charge pump. The charge pump requires only four 0.1- $\mu$ F capacitors and features a logic-level output (READY) that asserts when the charge pump is regulating and the device is ready to begin transmitting.

The MAX3318E achieves a 1- $\mu$ A supply current using the auto-power-down feature. This device automatically enters a low-power power-down mode when the RS-232 cable is disconnected or the drivers of the connected peripherals are inactive for more than 30 s. The device turns on again when it senses a valid transition at any driver or receiver input. Auto power down saves power without changes to the existing BIOS or operating system.

This device is available in two space-saving packages: 20-pin SSOP and 20-pin TSSOP.

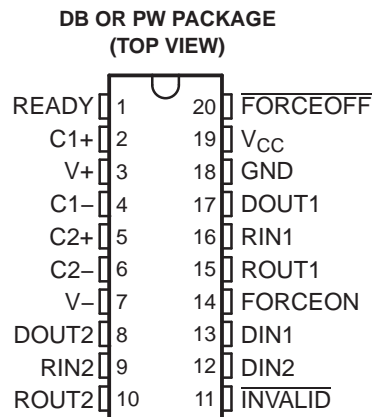

Please be aware that an important notice concerning availability, standard warranty, and use in critical applications of Texas Instruments semiconductor products and disclaimers thereto appears at the end of this data sheet.

**MAX3318E**  
**2.5-V 460-kbps RS-232 TRANSCEIVER**  
**WITH ±15-kV ESD PROTECTION**



SLLS741–JUNE 2006

**ORDERING INFORMATION**

T <sub>A</sub>	PACKAGE <sup>(1)</sup>		ORDERABLE PART NUMBER	TOP-SIDE MARKING
–0°C to 70°C	SSOP – DB	Tube of 70	MAX3318ECDB	MP318EC
		Reel of 2000	MAX3318ECDBR	
	TSSOP – PW	Tube of 70	MAX3318ECPW	MP318EC
		Reel of 2000	MAX3318ECPWR	
–40°C to 85°C	SSOP – DB	Tube of 70	MAX3318EIDB	MP318EI
		Reel of 2000	MAX3318EIDBR	
	TSSOP – PW	Tube of 70	MAX3318EIPW	MP318EI
		Reel of 2000	MAX3318EIPWR	

(1) Package drawings, standard packing quantities, thermal data, symbolization, and PCB design guidelines are available at [www.ti.com/sc/package](http://www.ti.com/sc/package).

**DETAILED DESCRIPTION**

Flexible control options for power management are featured when the serial port and driver inputs are inactive. The auto-power-down plus feature functions when FORCEON is low and FORCEOFF is high. During this mode of operation, if the device does not sense valid signal transitions on all receiver and driver inputs for approximately 30 s, the built-in charge pump and drivers are powered down, reducing the supply current to 1 μA. By disconnecting the serial port or placing the peripheral drivers off, auto-power-down plus can be disabled when FORCEON and FORCEOFF are high. With auto-power-down plus enabled, the device activates automatically when a valid signal is applied to any receiver or driver input. INVALID is high (valid data) if any receiver input voltage is greater than 2.7 V or less than –2.7 V, or has been between –0.3 V and 0.3 V for less than 30 μs (typical number). INVALID is low (invalid data) if all receiver input voltage are between –0.3 V and 0.3 V for more than 30 μs (typical number).

**FUNCTION TABLE<sup>(1)</sup>**

INPUT CONDITIONS				OUTPUT STATES				OPERATING MODE
FORCEON	$\overline{\text{FORCEOFF}}$	RECEIVER OR DRIVER EDGE WITHIN 30 s	VALID RS-232 LEVEL PRESENT AT RECEIVER	DRIVER	RECEIVER	$\overline{\text{INVALID}}$	READY	
<b>Auto-Power-Down Plus Conditions</b>								
H	H	No	No	Active	Active	L	H	Normal operation, auto-power-down plus disabled
H	H	No	Yes	Active	Active	H	H	Normal operation, auto-power-down plus disabled
L	H	Yes	No	Active	Active	L	H	Normal operation, auto-power-down plus enabled
L	H	Yes	Yes	Active	Active	H	H	Normal operation, auto-power-down plus enabled
L	H	No	No	Z	Active	L	L	Power down, auto-power-down plus enabled
L	H	No	Yes	Z	Active	H	L	Power down, auto-power-down plus enabled
X	L	X	No	Z	Active	L	L	Manual power down
X	L	X	Yes	Z	Active	H	L	Manual power down
<b>Auto-Power-Down Conditions</b>								
$\overline{\text{INVALID}}$	$\overline{\text{INVALID}}$	X	No	Z	Active	L	L	Power down, auto power down enabled
$\overline{\text{INVALID}}$	$\overline{\text{INVALID}}$	X	Yes	Active	Active	H	H	Normal operation, auto power down enabled

(1) H = high level, L = low level, X = irrelevant, Z = high impedance

**MAX3318E**  
**2.5-V 460-kbps RS-232 TRANSCEIVER**  
**WITH  $\pm 15$ -kV ESD PROTECTION**

SLLS741-JUNE 2006

**LOGIC DIAGRAM (POSITIVE LOGIC)**

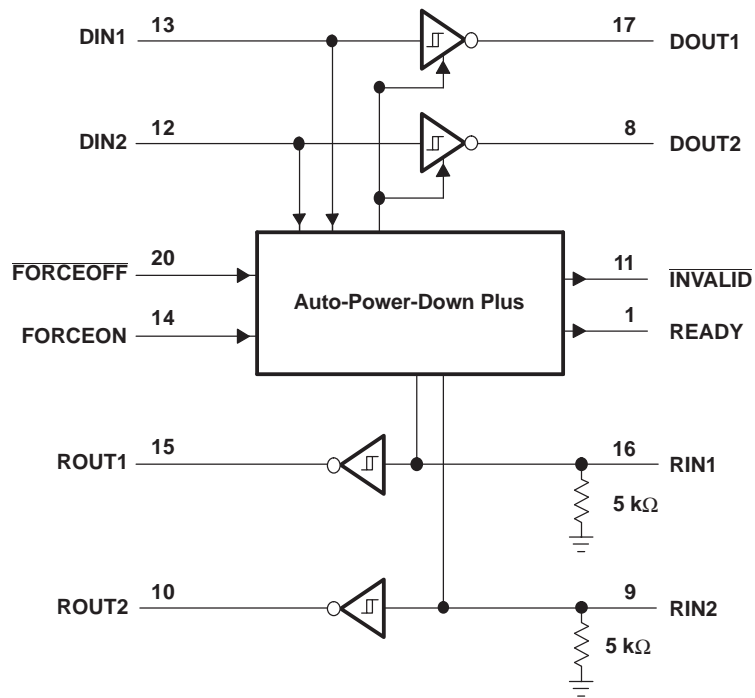

**TERMINAL FUNCTIONS**

TERMINAL		DESCRIPTION
NAME	NO.	
C1+	2	Positive voltage-doubler charge-pump capacitor
C1–	4	Negative voltage-doubler charge-pump capacitor
C2+	5	Positive inverting charge-pump capacitor
C2–	6	Negative inverting charge-pump capacitor
DIN	12, 13	CMOS driver inputs
DOUT	8, 17	RS-232 driver outputs
$\overline{\text{FORCEOFF}}$	20	Force-off input, active low. Drive low to power down transmitters, receivers, and charge pump. This overrides auto power down and FORCEON (see Function Table).
FORCEON	14	Force-on input, active high. Drive high to override auto power down, keeping transmitters and receivers on (FORCEOFF must be high) (see Function Table).
GND	18	Ground
$\overline{\text{INVALID}}$	11	Valid signal detector output, active low. A logic high indicates that a valid RS-232 level is present on a receiver input.
READY	1	Ready to transmit output, active high. READY is enabled high when V– goes below –3.5 V and the device is ready to transmit.
RIN	9, 16	RS-232 receiver inputs
ROUT	10, 15	CMOS receiver outputs
V+	3	$2 \times V_{\text{CC}}$ generated by the charge pump
V–	7	$-2 \times V_{\text{CC}}$ generated by the charge pump
V <sub>CC</sub>	19	2.25-V to 3-V single-supply voltage

**MAX3318E**  
**2.5-V 460-kbps RS-232 TRANSCEIVER**  
**WITH  $\pm 15$ -kV ESD PROTECTION**

SLLS741–JUNE 2006

**Absolute Maximum Ratings<sup>(1)</sup>**

over operating free-air temperature range (unless otherwise noted)

		MIN	MAX	UNIT
V <sub>CC</sub> to GND		-0.3	6	V
V+ to GND <sup>(2)</sup>		-0.3	7	V
V- to GND <sup>(2)</sup>		-7	0.3	V
V+ + IV-I <sup>(2)</sup>			13	V
Input voltage	DIN, FORCEON, FORCEOFF to GND	-0.3	6	V
	RIN to GND		$\pm 25$	
Output voltage	DOUT to GND		$\pm 13.2$	V
	ROUT, INVALID, READY to GND	-0.3	V <sub>CC</sub> + 0.3	
Short-circuit duration	DOUT to GND		Continuous	
Continuous power dissipation (T <sub>A</sub> = 70°C)	16-pin SSOP (derate 7.14 mW/°C above 70°C)		571	mW
	20-pin SSOP (derate 8 mW/°C above 70°C)		640	
	20-pin TSSOP (derate 7 mW/°C above 70°C)		559	
Storage temperature range		-65	150	°C
Lead temperature (soldering, 10 s)			300	°C

- (1) Stresses beyond those listed under "absolute maximum ratings" may cause permanent damage to the device. These are stress ratings only, and functional operation of the device at these or any other conditions beyond those indicated under "recommended operating conditions" is not implied. Exposure to absolute-maximum-rated conditions for extended periods may affect device reliability.
- (2) V+ and V- can have maximum magnitudes of 7 V, but their absolute difference cannot exceed 13 V.

**Recommended Operating Conditions**

See Figure 4

				MIN	NOM	MAX	UNIT
Supply voltage				2.25	2.5	3	V
V <sub>IH</sub>	Driver and control high-level input voltage	DIN, FORCEOFF, FORCEON	V <sub>CC</sub> = 2.5 V to 3 V	0.7 × V <sub>CC</sub>		5.5	V
V <sub>IL</sub>	Driver and control low-level input voltage	DIN, FORCEOFF, FORCEON	V <sub>CC</sub> = 2.5 V to 3 V	0		0.3 × V <sub>CC</sub>	V
V <sub>I</sub>	Receiver input voltage			-25		25	V
T <sub>A</sub>	Operating free-air temperature	MAX3318EC		0		70	°C
		MAX3318EI		-40		85	

**Supply Current Section Electrical Characteristics**
 $V_{CC} = 2.25\text{ V to }3\text{ V}$ ,  $C1\text{--}C4 = 0.1\ \mu\text{F}$ ,  $T_A = T_{MIN}\text{ to }T_{MAX}$  (unless otherwise noted)

PARAMETER	TEST CONDITIONS	MIN	TYP <sup>(1)</sup>	MAX	UNIT
<b>DC Characteristics (<math>V_{CC} = 2.5\text{ V}</math>, <math>T_A = 25^\circ\text{C}</math>)</b>					
Auto-power-down plus supply current	FORCEON = GND, FORCEOFF = $V_{CC}$ , All RIN and DIN idle		1	10	$\mu\text{A}$
Auto-power-down supply current	FORCEOFF = GND		1	10	$\mu\text{A}$
Supply current	FORCEON = $\overline{\text{FORCEOFF}} = V_{CC}$ , No load		0.3	2	mA

 (1) Typical values are at  $V_{CC} = 2.5\text{ V}$ ,  $T_A = 25^\circ\text{C}$ .

**ESD Protection**

PARAMETER	TEST CONDITIONS	TYP	UNIT
RIN, DOUT	HBM	$\pm 15$	kV
	IEC 61000-4-2 Air-Gap Discharge method	$\pm 15$	
	IEC 61000-4-2 Contact Discharge method	$\pm 8$	

**MAX3318E**  
**2.5-V 460-kbps RS-232 TRANSCEIVER**  
**WITH  $\pm 15$ -kV ESD PROTECTION**

SLLS741–JUNE 2006

**Driver Section Electrical Characteristics**

over recommended ranges of supply voltage and operating free-air temperature,  
 $V_{CC} = 2.25\text{ V to }3\text{ V}$ ,  $C1\text{--}C4 = 0.1\ \mu\text{F}$ ,  $T_A = T_{MIN}$  to  $T_{MAX}$  (unless otherwise noted) (see [Figure 4](#))

PARAMETER	TEST CONDITIONS	MIN	TYP <sup>(1)</sup>	MAX	UNIT
Driver input hysteresis			0.3		V
Input leakage current	FORCEON, DIN, $\overline{\text{FORCEOFF}}$		$\pm 0.01$	$\pm 1$	$\mu\text{A}$
Output voltage swing	All driver outputs loaded with 3 k $\Omega$ to ground	$\pm 3.7$	$\pm 4$		V
Output resistance	$V_{CC} = 0$ , Driver output = $\pm 2\text{ V}$	300	10M		$\Omega$
Output short-circuit current <sup>(2)</sup>			$\pm 25$	$\pm 60$	mA
Output leakage current	$V_{CC} = 0$ or 2.25 V to 3 V, $V_{OUT} = \pm 12\text{ V}$ , Drivers disabled			$\pm 25$	$\mu\text{A}$

(1) Typical values are at  $V_{CC} = 2.5\text{ V}$ ,  $T_A = 25^\circ\text{C}$ .

(2) Short-circuit durations should be controlled to prevent exceeding the device absolute power dissipation ratings, and not more than one output should be shorted at a time.

**Driver Section Switching Characteristics**

over recommended ranges of supply voltage and operating free-air temperature,  
 $V_{CC} = 2.25\text{ V to }3\text{ V}$ ,  $C1\text{--}C4 = 0.1\ \mu\text{F}$ ,  $T_A = T_{MIN}$  to  $T_{MAX}$  (unless otherwise noted) (see [Figure 1](#))

PARAMETER	TEST CONDITIONS	MIN	TYP <sup>(1)</sup>	MAX	UNIT
Maximum data rate	$R_L = 3\text{ k}\Omega$ , $C_L = 1000\text{ pF}$ , One transmitter switching	460			kbps
$ t_{PHL} - t_{PLH} $ Driver skew <sup>(2)</sup>			100		ns
Transition-region slew rate	$V_{CC} = 2.5\text{ V}$ , $T_A = 25^\circ\text{C}$ , $R_L = 3\text{ k}\Omega$ to 7 k $\Omega$ , Measured from 3 V to $-3\text{ V}$ or $-3\text{ V}$ to 3 V, $C_L = 150\text{ pF}$ to 2500 pF	4		30	V/ $\mu\text{s}$

(1) Typical values are at  $V_{CC} = 2.5\text{ V}$ ,  $T_A = 25^\circ\text{C}$ .

(2) Pulse skew is defined as  $|t_{PLH} - t_{PHL}|$  of each channel of the same device.

### Receiver Section Electrical Characteristics

over recommended ranges of supply voltage and operating free-air temperature,  
 $V_{CC} = 2.25\text{ V to }3\text{ V}$ ,  $C1\text{--}C4 = 0.1\ \mu\text{F}$ ,  $T_A = T_{MIN}$  to  $T_{MAX}$  (unless otherwise noted) (see [Figure 4](#))

PARAMETER	TEST CONDITIONS	MIN	TYP <sup>(1)</sup>	MAX	UNIT
Input voltage range		-25		25	V
Input threshold low	$T_A = 25^\circ\text{C}$			$0.3 \times V_{CC}$	V
Input threshold high	$T_A = 25^\circ\text{C}$	$0.7 \times V_{CC}$			V
Input hysteresis			0.3		V
Input resistance	$T_A = 25^\circ\text{C}$	3	5	7	k $\Omega$
Output leakage current			$\pm 0.05$	$\pm 10$	$\mu\text{A}$
Output voltage low	$I_{OUT} = 0.5\text{ mA}$			$0.1 \times V_{CC}$	V
Output voltage high	$I_{OUT} = -0.5\text{ mA}$	$0.9 \times V_{CC}$			V

(1) Typical values are at  $V_{CC} = 2.5\text{ V}$ ,  $T_A = 25^\circ\text{C}$ .

### Receiver Section Switching Characteristics

over recommended ranges of supply voltage and operating free-air temperature,  
 $V_{CC} = 2.25\text{ V to }3\text{ V}$ ,  $C1\text{--}C4 = 0.1\ \mu\text{F}$ ,  $T_A = T_{MIN}$  to  $T_{MAX}$  (unless otherwise noted) (see [Figure 4](#))

PARAMETER		TEST CONDITIONS	TYP <sup>(1)</sup>	UNIT
$t_{PHL}$	Receiver propagation delay	RIN to ROUT, $C_L = 150\text{ pF}$	0.175	$\mu\text{s}$
$t_{PLH}$			0.175	
$ t_{PHL} - t_{PLH} $	Receiver skew <sup>(2)</sup>		50	ns

(1) Typical values are at  $V_{CC} = 2.5\text{ V}$ ,  $T_A = 25^\circ\text{C}$ .

(2) Pulse skew is defined as  $|t_{PLH} - t_{PHL}|$  of each channel of the same device.

**MAX3318E**  
**2.5-V 460-kbps RS-232 TRANSCEIVER**  
**WITH  $\pm 15$ -kV ESD PROTECTION**

SLLS741–JUNE 2006

**Auto-Power-Down Plus Section Electrical Characteristics**

over recommended ranges of supply voltage and operating free-air temperature,  
 $V_{CC} = 2.25\text{ V to }3\text{ V}$ ,  $C1\text{--}C4 = 0.1\ \mu\text{F}$ ,  $T_A = T_{MIN}$  to  $T_{MAX}$  (unless otherwise noted) (see [Figure 4](#))

PARAMETER	TEST CONDITIONS	MIN	MAX	UNIT
Receiver input threshold to $\overline{\text{INVALID}}$ high	Positive threshold		2.7	V
	Negative threshold	-2.7		
Receiver input threshold $\overline{\text{INVALID}}$ low		-0.3	0.3	V
$\overline{\text{INVALID}}$ , READY voltage low	$I_{OUT} = 0.5\text{ mA}$		$0.1 \times V_{CC}$	V
$\overline{\text{INVALID}}$ , READY voltage high	$I_{OUT} = -0.5\text{ mA}$	$0.8 \times V_{CC}$		V

**Auto-Power-Down Plus Section Switching Characteristics**

over recommended ranges of supply voltage and operating free-air temperature,  
 $V_{CC} = 2.25\text{ V to }3\text{ V}$ ,  $C1\text{--}C4 = 0.1\ \mu\text{F}$ ,  $T_A = T_{MIN}$  to  $T_{MAX}$  (unless otherwise noted) (see [Figure 4](#))

PARAMETER	TEST CONDITIONS	MIN	TYP <sup>(1)</sup>	MAX	UNIT
$t_{INVH}$ Receiver positive or negative threshold to $\overline{\text{INVALID}}$ high	$V_{CC} = 2.5\text{ V}$		1		$\mu\text{s}$
$t_{INVL}$ Receiver positive or negative threshold to $\overline{\text{INVALID}}$ low	$V_{CC} = 2.5\text{ V}$		30		$\mu\text{s}$
$t_{WU}$ Receiver or driver edge to driver enabled	$V_{CC} = 2.5\text{ V}$		100		$\mu\text{s}$
$t_{AUTOPRDN}$ Receiver or driver edge to driver shutdown	$V_{CC} = 2.5\text{ V}$	15	30	60	s

(1) Typical values are at  $V_{CC} = 2.5\text{ V}$ ,  $T_A = 25^\circ\text{C}$ .

**PARAMETER MEASUREMENT INFORMATION**

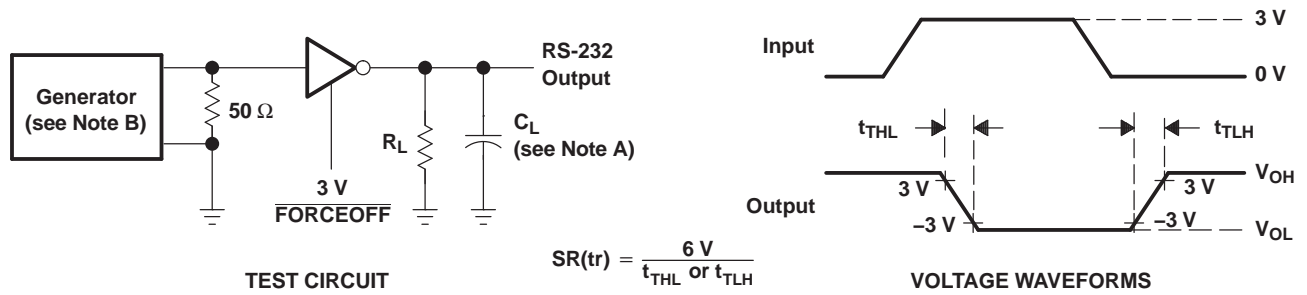

NOTES: A.  $C_L$  includes probe and jig capacitance.  
 B. The pulse generator has the following characteristics: PRR = 250 kbit/s,  $Z_O = 50\ \Omega$ , 50% duty cycle,  $t_r \leq 10\text{ ns}$ ,  $t_f \leq 10\text{ ns}$ .

**Figure 1. Driver Slew Rate**

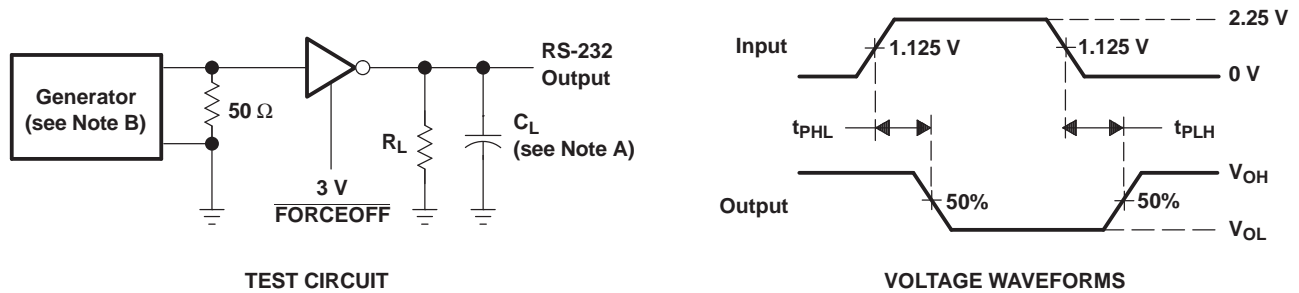

NOTES: A.  $C_L$  includes probe and jig capacitance.  
 B. The pulse generator has the following characteristics: PRR = 250 kbit/s,  $Z_O = 50\ \Omega$ , 50% duty cycle,  $t_r \leq 10\text{ ns}$ ,  $t_f \leq 10\text{ ns}$ .

**Figure 2. Driver Pulse Skew**

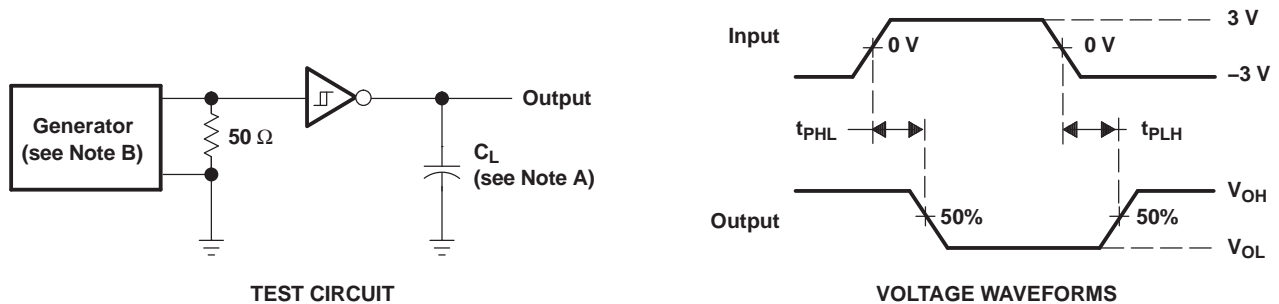

NOTES: A.  $C_L$  includes probe and jig capacitance.  
 B. The pulse generator has the following characteristics:  $Z_O = 50\ \Omega$ , 50% duty cycle,  $t_r \leq 10\text{ ns}$ ,  $t_f \leq 10\text{ ns}$ .

**Figure 3. Receiver Propagation Delay Times**

**PARAMETER MEASUREMENT INFORMATION**

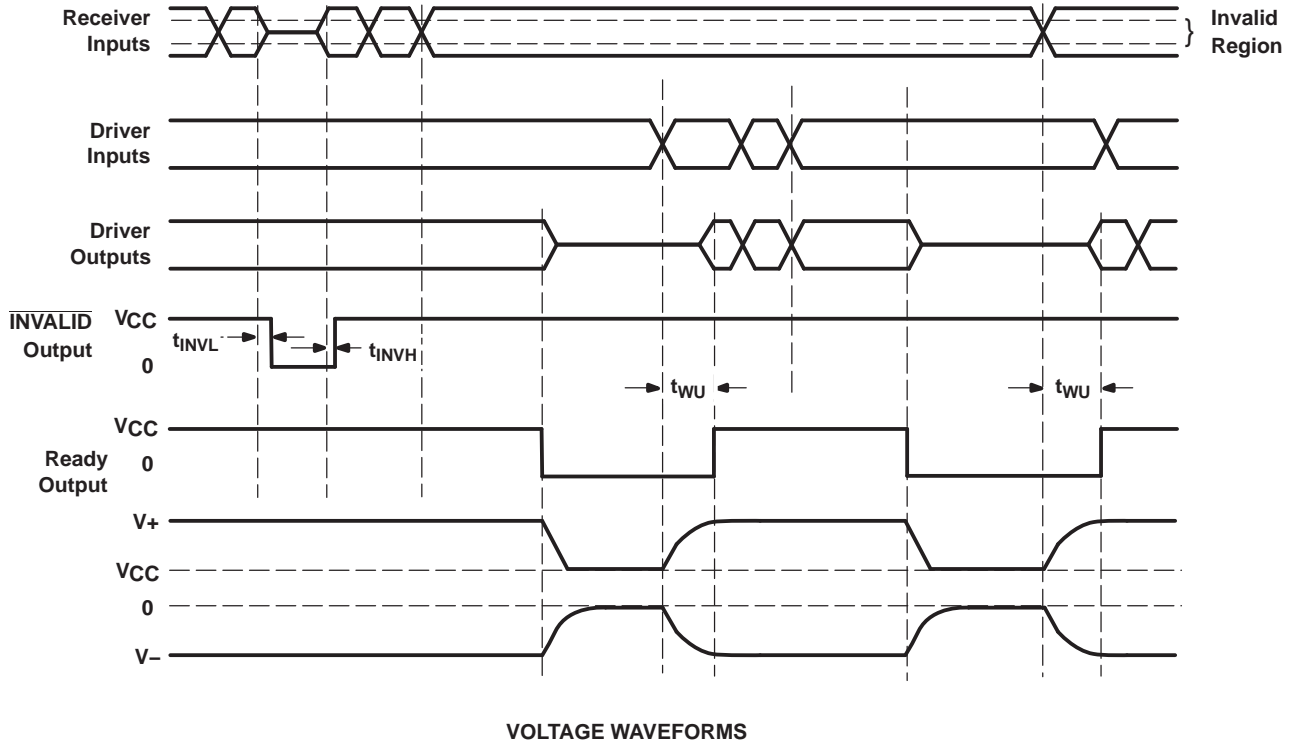

**VOLTAGE WAVEFORMS**

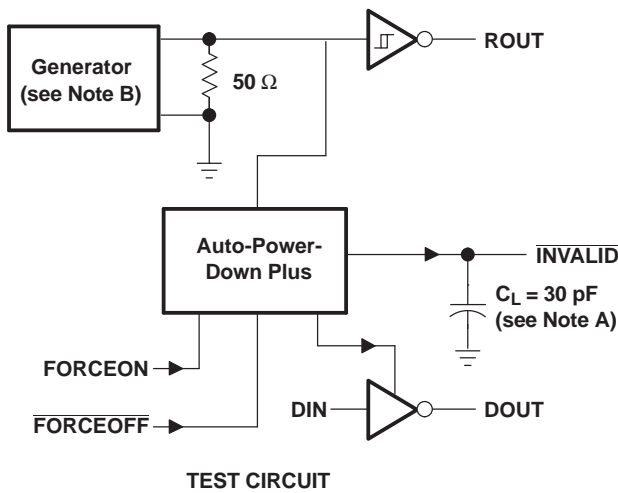

**TEST CIRCUIT**

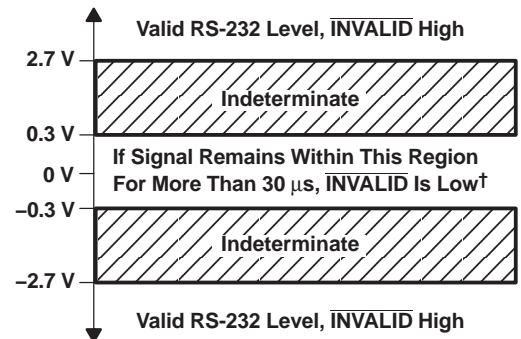

† Auto power down disables drivers and reduces supply current to 1 μA.

**Figure 4. INVALID Propagation Delay Times and Supply Enabling Time**

**PARAMETER MEASUREMENT INFORMATION**

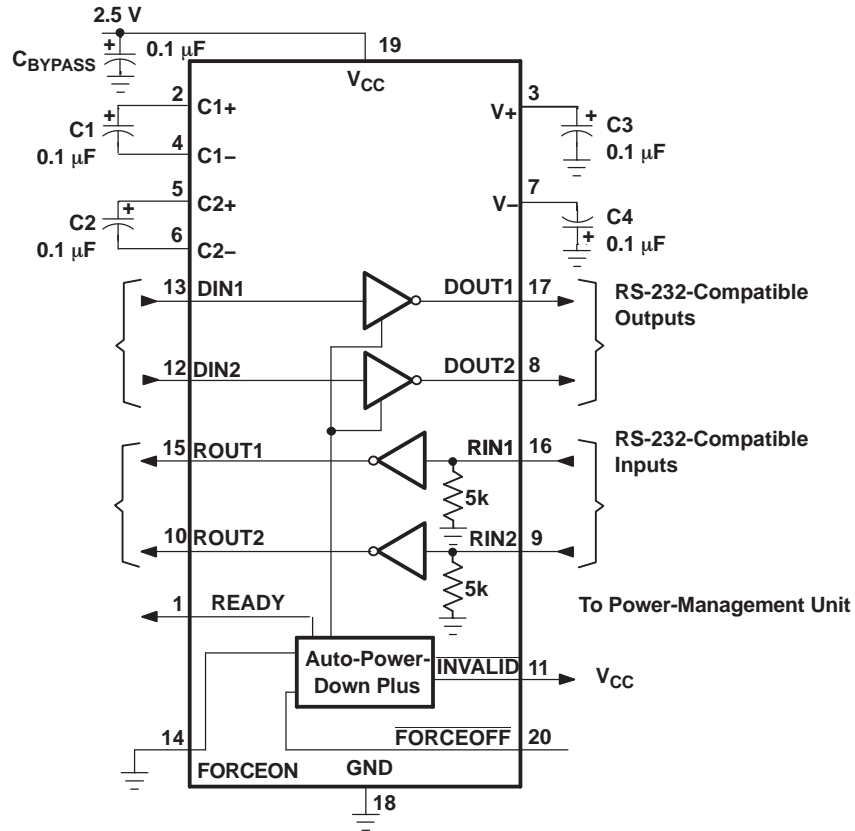

**Figure 5. Typical Application Circuit**

**PACKAGING INFORMATION**

Orderable Device	Status <sup>(1)</sup>	Package Type	Package Drawing	Pins	Package Qty	Eco Plan <sup>(2)</sup>	Lead/Ball Finish	MSL Peak Temp <sup>(3)</sup>
MAX3318ECDB	ACTIVE	SSOP	DB	20	70	Green (RoHS & no Sb/Br)	CU NIPDAU	Level-1-260C-UNLIM
MAX3318ECDBG4	ACTIVE	SSOP	DB	20	70	Green (RoHS & no Sb/Br)	CU NIPDAU	Level-1-260C-UNLIM
MAX3318ECDBR	ACTIVE	SSOP	DB	20	2000	Green (RoHS & no Sb/Br)	CU NIPDAU	Level-1-260C-UNLIM
MAX3318ECDBRG4	ACTIVE	SSOP	DB	20	2000	Green (RoHS & no Sb/Br)	CU NIPDAU	Level-1-260C-UNLIM
MAX3318ECPW	ACTIVE	TSSOP	PW	20	70	Green (RoHS & no Sb/Br)	CU NIPDAU	Level-1-260C-UNLIM
MAX3318ECPWG4	ACTIVE	TSSOP	PW	20	70	Green (RoHS & no Sb/Br)	CU NIPDAU	Level-1-260C-UNLIM
MAX3318ECPWR	ACTIVE	TSSOP	PW	20	2000	Green (RoHS & no Sb/Br)	CU NIPDAU	Level-1-260C-UNLIM
MAX3318ECPWRG4	ACTIVE	TSSOP	PW	20	2000	Green (RoHS & no Sb/Br)	CU NIPDAU	Level-1-260C-UNLIM
MAX3318EIDB	ACTIVE	SSOP	DB	20	70	Green (RoHS & no Sb/Br)	CU NIPDAU	Level-1-260C-UNLIM
MAX3318EIDBG4	ACTIVE	SSOP	DB	20	70	Green (RoHS & no Sb/Br)	CU NIPDAU	Level-1-260C-UNLIM
MAX3318EIDBR	ACTIVE	SSOP	DB	20	2000	Green (RoHS & no Sb/Br)	CU NIPDAU	Level-1-260C-UNLIM
MAX3318EIDBRG4	ACTIVE	SSOP	DB	20	2000	Green (RoHS & no Sb/Br)	CU NIPDAU	Level-1-260C-UNLIM
MAX3318EIPW	ACTIVE	TSSOP	PW	20	70	Green (RoHS & no Sb/Br)	CU NIPDAU	Level-1-260C-UNLIM
MAX3318EIPWG4	ACTIVE	TSSOP	PW	20	70	Green (RoHS & no Sb/Br)	CU NIPDAU	Level-1-260C-UNLIM
MAX3318EIPWR	ACTIVE	TSSOP	PW	20	2000	Green (RoHS & no Sb/Br)	CU NIPDAU	Level-1-260C-UNLIM
MAX3318EIPWRG4	ACTIVE	TSSOP	PW	20	2000	Green (RoHS & no Sb/Br)	CU NIPDAU	Level-1-260C-UNLIM

<sup>(1)</sup> The marketing status values are defined as follows:

**ACTIVE:** Product device recommended for new designs.

**LIFEBUY:** TI has announced that the device will be discontinued, and a lifetime-buy period is in effect.

**NRND:** Not recommended for new designs. Device is in production to support existing customers, but TI does not recommend using this part in a new design.

**PREVIEW:** Device has been announced but is not in production. Samples may or may not be available.

**OBSOLETE:** TI has discontinued the production of the device.

<sup>(2)</sup> Eco Plan - The planned eco-friendly classification: Pb-Free (RoHS), Pb-Free (RoHS Exempt), or Green (RoHS & no Sb/Br) - please check <http://www.ti.com/productcontent> for the latest availability information and additional product content details.

**TBD:** The Pb-Free/Green conversion plan has not been defined.

**Pb-Free (RoHS):** TI's terms "Lead-Free" or "Pb-Free" mean semiconductor products that are compatible with the current RoHS requirements for all 6 substances, including the requirement that lead not exceed 0.1% by weight in homogeneous materials. Where designed to be soldered at high temperatures, TI Pb-Free products are suitable for use in specified lead-free processes.

**Pb-Free (RoHS Exempt):** This component has a RoHS exemption for either 1) lead-based flip-chip solder bumps used between the die and package, or 2) lead-based die adhesive used between the die and leadframe. The component is otherwise considered Pb-Free (RoHS compatible) as defined above.

**Green (RoHS & no Sb/Br):** TI defines "Green" to mean Pb-Free (RoHS compatible), and free of Bromine (Br) and Antimony (Sb) based flame retardants (Br or Sb do not exceed 0.1% by weight in homogeneous material)

<sup>(3)</sup> MSL, Peak Temp. -- The Moisture Sensitivity Level rating according to the JEDEC industry standard classifications, and peak solder temperature.

**Important Information and Disclaimer:**The information provided on this page represents TI's knowledge and belief as of the date that it is provided. TI bases its knowledge and belief on information provided by third parties, and makes no representation or warranty as to the accuracy of such information. Efforts are underway to better integrate information from third parties. TI has taken and continues to take reasonable steps to provide representative and accurate information but may not have conducted destructive testing or chemical analysis on incoming materials and chemicals. TI and TI suppliers consider certain information to be proprietary, and thus CAS numbers and other limited information may not be available for release.

In no event shall TI's liability arising out of such information exceed the total purchase price of the TI part(s) at issue in this document sold by TI to Customer on an annual basis.

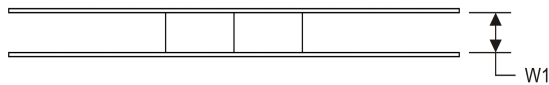
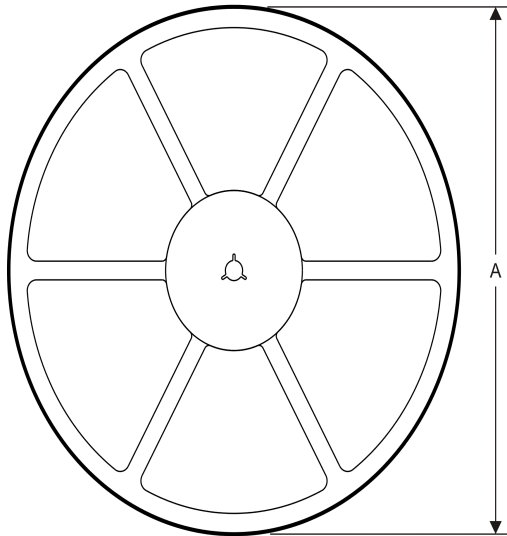
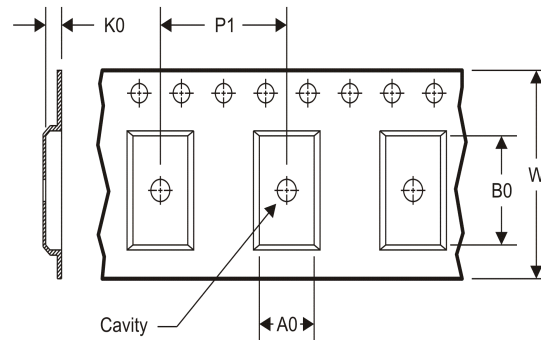
**TAPE AND REEL INFORMATION**
**REEL DIMENSIONS**

**TAPE DIMENSIONS**

A0	Dimension designed to accommodate the component width
B0	Dimension designed to accommodate the component length
K0	Dimension designed to accommodate the component thickness
W	Overall width of the carrier tape
P1	Pitch between successive cavity centers

**TAPE AND REEL INFORMATION**

\*All dimensions are nominal

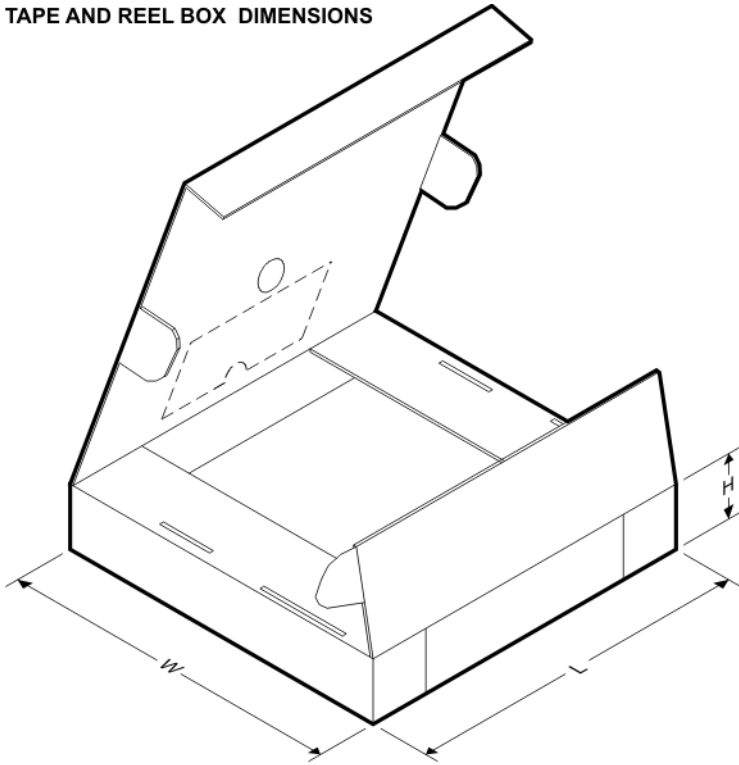
Device	Package Type	Package Drawing	Pins	SPQ	Reel Diameter (mm)	Reel Width W1 (mm)	A0 (mm)	B0 (mm)	K0 (mm)	P1 (mm)	W (mm)	Pin1 Quadrant
MAX3318ECDBR	SSOP	DB	20	2000	330.0	16.4	8.2	7.5	2.5	12.0	16.0	Q1
MAX3318ECPWR	TSSOP	PW	20	2000	330.0	16.4	6.95	7.1	1.6	8.0	16.0	Q1
MAX3318EIDBR	SSOP	DB	20	2000	330.0	16.4	8.2	7.5	2.5	12.0	16.0	Q1
MAX3318EIPWR	TSSOP	PW	20	2000	330.0	16.4	6.95	7.1	1.6	8.0	16.0	Q1

**TAPE AND REEL BOX DIMENSIONS**

\*All dimensions are nominal



Device	Package Type	Package Drawing	Pins	SPQ	Length (mm)	Width (mm)	Height (mm)
MAX3318ECDBR	SSOP	DB	20	2000	367.0	367.0	38.0
MAX3318ECPWR	TSSOP	PW	20	2000	367.0	367.0	38.0
MAX3318EIDBR	SSOP	DB	20	2000	367.0	367.0	38.0
MAX3318EIPWR	TSSOP	PW	20	2000	367.0	367.0	38.0

PW (R-PDSO-G20)

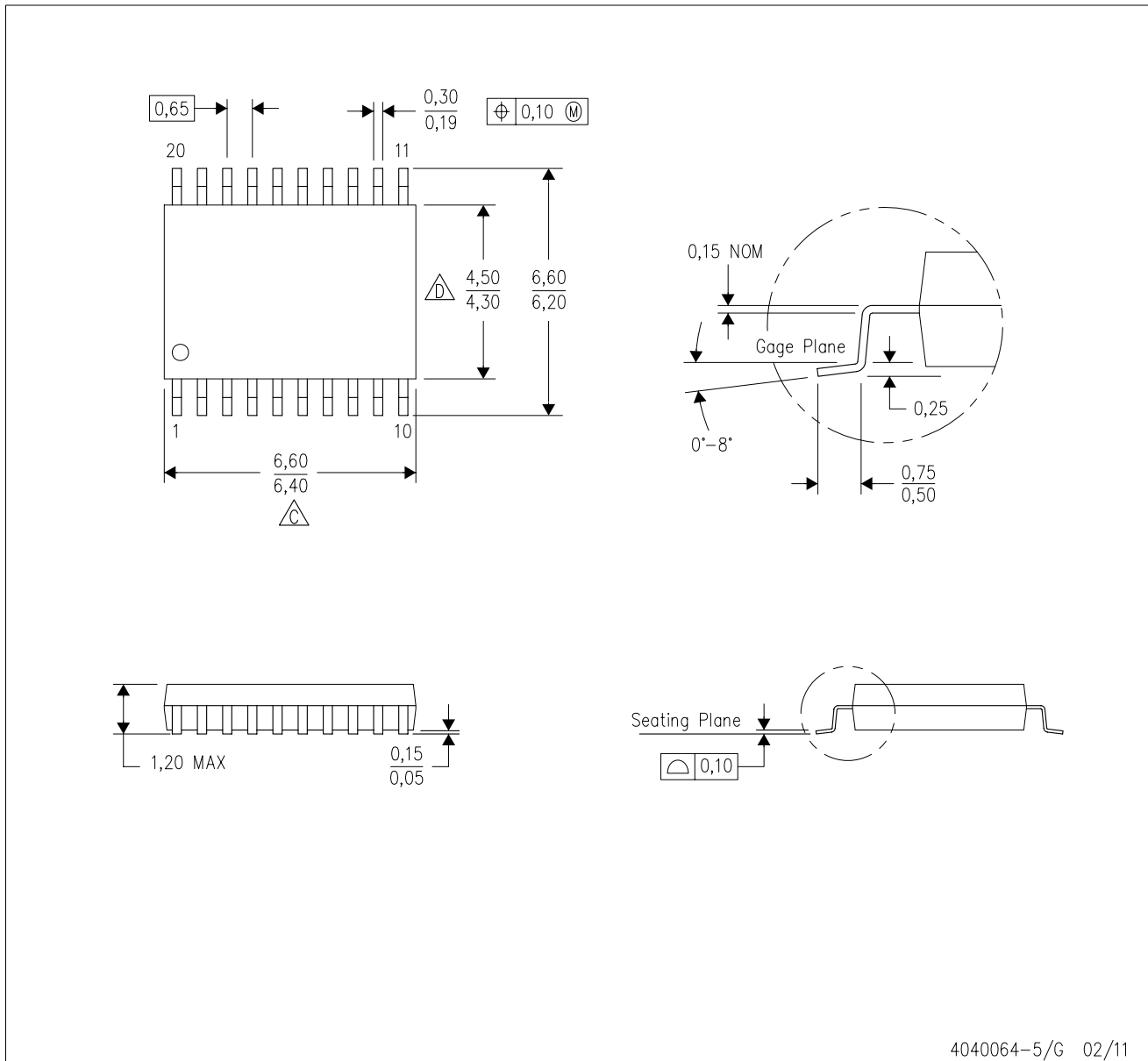
PLASTIC SMALL OUTLINE



4040064-5/G 02/11

- NOTES:
- A. All linear dimensions are in millimeters. Dimensioning and tolerancing per ASME Y14.5M-1994.
  - B. This drawing is subject to change without notice.
  -  Body length does not include mold flash, protrusions, or gate burrs. Mold flash, protrusions, or gate burrs shall not exceed 0,15 each side.
  -  Body width does not include interlead flash. Interlead flash shall not exceed 0,25 each side.
  - E. Falls within JEDEC MO-153

PW (R-PDSO-G20)

PLASTIC SMALL OUTLINE

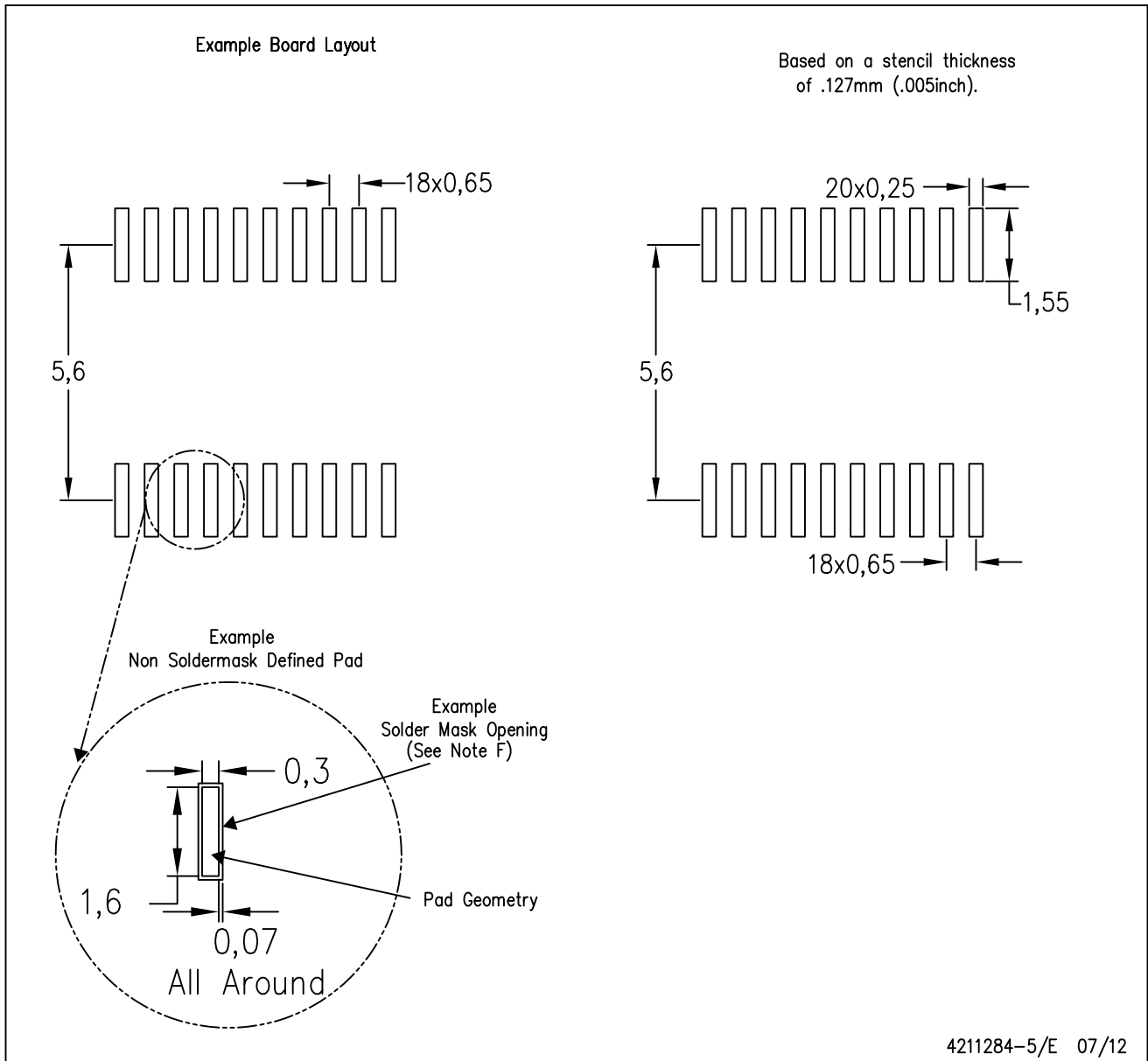

- NOTES:
- A. All linear dimensions are in millimeters.
  - B. This drawing is subject to change without notice.
  - C. Publication IPC-7351 is recommended for alternate design.
  - D. Laser cutting apertures with trapezoidal walls and also rounding corners will offer better paste release. Customers should contact their board assembly site for stencil design recommendations. Refer to IPC-7525 for other stencil recommendations.
  - E. Customers should contact their board fabrication site for solder mask tolerances between and around signal pads.

DB (R-PDSO-G\*\*)

PLASTIC SMALL-OUTLINE

28 PINS SHOWN

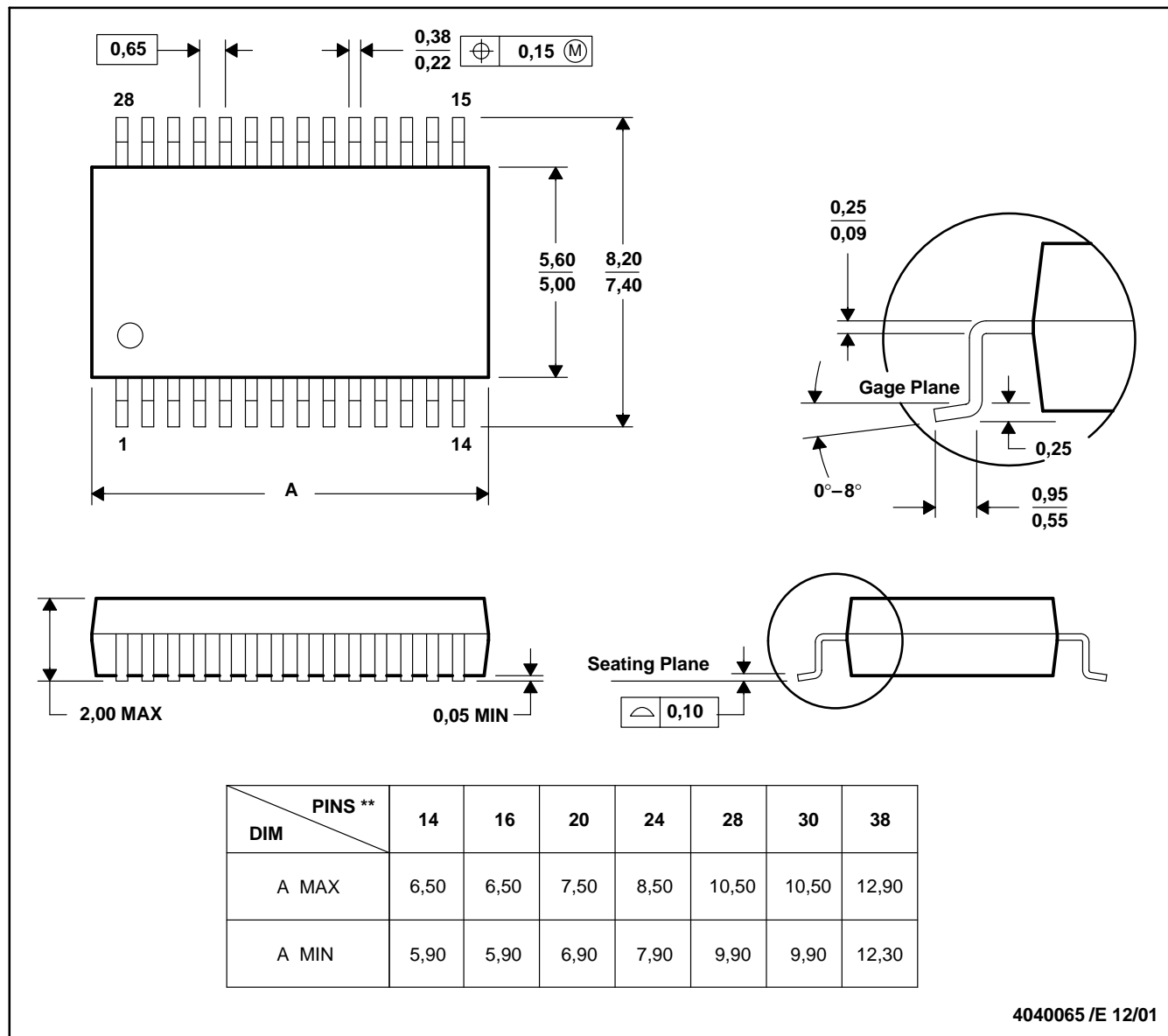

- NOTES: A. All linear dimensions are in millimeters.  
 B. This drawing is subject to change without notice.  
 C. Body dimensions do not include mold flash or protrusion not to exceed 0,15.  
 D. Falls within JEDEC MO-150

## IMPORTANT NOTICE

Texas Instruments Incorporated and its subsidiaries (TI) reserve the right to make corrections, enhancements, improvements and other changes to its semiconductor products and services per JESD46C and to discontinue any product or service per JESD48B. Buyers should obtain the latest relevant information before placing orders and should verify that such information is current and complete. All semiconductor products (also referred to herein as "components") are sold subject to TI's terms and conditions of sale supplied at the time of order acknowledgment.

TI warrants performance of its components to the specifications applicable at the time of sale, in accordance with the warranty in TI's terms and conditions of sale of semiconductor products. Testing and other quality control techniques are used to the extent TI deems necessary to support this warranty. Except where mandated by applicable law, testing of all parameters of each component is not necessarily performed.

TI assumes no liability for applications assistance or the design of Buyers' products. Buyers are responsible for their products and applications using TI components. To minimize the risks associated with Buyers' products and applications, Buyers should provide adequate design and operating safeguards.

TI does not warrant or represent that any license, either express or implied, is granted under any patent right, copyright, mask work right, or other intellectual property right relating to any combination, machine, or process in which TI components or services are used. Information published by TI regarding third-party products or services does not constitute a license to use such products or services or a warranty or endorsement thereof. Use of such information may require a license from a third party under the patents or other intellectual property of the third party, or a license from TI under the patents or other intellectual property of TI.

Reproduction of significant portions of TI information in TI data books or data sheets is permissible only if reproduction is without alteration and is accompanied by all associated warranties, conditions, limitations, and notices. TI is not responsible or liable for such altered documentation. Information of third parties may be subject to additional restrictions.

Resale of TI components or services with statements different from or beyond the parameters stated by TI for that component or service voids all express and any implied warranties for the associated TI component or service and is an unfair and deceptive business practice. TI is not responsible or liable for any such statements.

Buyer acknowledges and agrees that it is solely responsible for compliance with all legal, regulatory and safety-related requirements concerning its products, and any use of TI components in its applications, notwithstanding any applications-related information or support that may be provided by TI. Buyer represents and agrees that it has all the necessary expertise to create and implement safeguards which anticipate dangerous consequences of failures, monitor failures and their consequences, lessen the likelihood of failures that might cause harm and take appropriate remedial actions. Buyer will fully indemnify TI and its representatives against any damages arising out of the use of any TI components in safety-critical applications.

In some cases, TI components may be promoted specifically to facilitate safety-related applications. With such components, TI's goal is to help enable customers to design and create their own end-product solutions that meet applicable functional safety standards and requirements. Nonetheless, such components are subject to these terms.

No TI components are authorized for use in FDA Class III (or similar life-critical medical equipment) unless authorized officers of the parties have executed a special agreement specifically governing such use.

Only those TI components which TI has specifically designated as military grade or "enhanced plastic" are designed and intended for use in military/aerospace applications or environments. Buyer acknowledges and agrees that any military or aerospace use of TI components which have **not** been so designated is solely at the Buyer's risk, and that Buyer is solely responsible for compliance with all legal and regulatory requirements in connection with such use.

TI has specifically designated certain components which meet ISO/TS16949 requirements, mainly for automotive use. Components which have not been so designated are neither designed nor intended for automotive use; and TI will not be responsible for any failure of such components to meet such requirements.

### Products

Audio	<a href="http://www.ti.com/audio">www.ti.com/audio</a>
Amplifiers	<a href="http://amplifier.ti.com">amplifier.ti.com</a>
Data Converters	<a href="http://dataconverter.ti.com">dataconverter.ti.com</a>
DLP® Products	<a href="http://www.dlp.com">www.dlp.com</a>
DSP	<a href="http://dsp.ti.com">dsp.ti.com</a>
Clocks and Timers	<a href="http://www.ti.com/clocks">www.ti.com/clocks</a>
Interface	<a href="http://interface.ti.com">interface.ti.com</a>
Logic	<a href="http://logic.ti.com">logic.ti.com</a>
Power Mgmt	<a href="http://power.ti.com">power.ti.com</a>
Microcontrollers	<a href="http://microcontroller.ti.com">microcontroller.ti.com</a>
RFID	<a href="http://www.ti-rfid.com">www.ti-rfid.com</a>
OMAP Mobile Processors	<a href="http://www.ti.com/omap">www.ti.com/omap</a>
Wireless Connectivity	<a href="http://www.ti.com/wirelessconnectivity">www.ti.com/wirelessconnectivity</a>

### Applications

Automotive and Transportation	<a href="http://www.ti.com/automotive">www.ti.com/automotive</a>
Communications and Telecom	<a href="http://www.ti.com/communications">www.ti.com/communications</a>
Computers and Peripherals	<a href="http://www.ti.com/computers">www.ti.com/computers</a>
Consumer Electronics	<a href="http://www.ti.com/consumer-apps">www.ti.com/consumer-apps</a>
Energy and Lighting	<a href="http://www.ti.com/energy">www.ti.com/energy</a>
Industrial	<a href="http://www.ti.com/industrial">www.ti.com/industrial</a>
Medical	<a href="http://www.ti.com/medical">www.ti.com/medical</a>
Security	<a href="http://www.ti.com/security">www.ti.com/security</a>
Space, Avionics and Defense	<a href="http://www.ti.com/space-avionics-defense">www.ti.com/space-avionics-defense</a>
Video and Imaging	<a href="http://www.ti.com/video">www.ti.com/video</a>

**TI E2E Community** [e2e.ti.com](http://e2e.ti.com)