

FEATURES

- ESD Protection for RS-232 I/O Pins
 - ± 15 kV (Human-Body Model)
 - ± 8 kV (IEC 61000, Contact Discharge)
 - ± 8 kV (IEC 61000, Air-Gap Discharge)
- 300- μ A Operating Supply Current
- 1- μ A Low-Power Standby (With Receivers Active) Mode
- Designed to Transmit at a Data Rate of 460 kbps
- Auto-Power-Down Plus Option Features Flexible Power-Saving Mode
- Operates From a Single 2.25-V to 3-V V_{CC} Supply

- Cellular Phones
- Notebooks
- Hand-Held Equipment
- Pagers

APPLICATIONS

- Battery-Powered Systems
- PDAs

DB OR PW PACKAGE
(TOP VIEW)

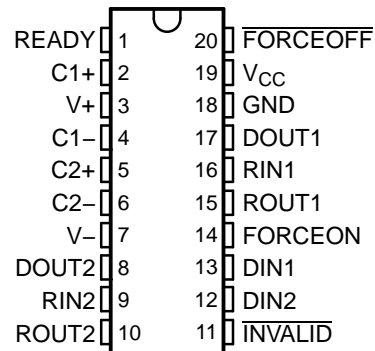

DESCRIPTION/ORDERING INFORMATION

The MAX3318 is a dual-driver, dual-receiver, RS-232 compatible transceiver. The device features auto-power-down plus and enhanced electrostatic discharge (ESD) protection integrated into the chip. Driver output and receiver input are protected to ± 8 kV using the IEC 61000 Air-Gap Discharge method, ± 8 kV using the IEC 61000 Contact Discharge method, and ± 15 kV using the Human-Body Model (HBM).

The device operates at a data rate of 460 kbps. The transceiver has a proprietary low-dropout driver output stage enabling RS-232-compatible operation from a 2.25-V to 3-V supply with a dual charge pump. The charge pump requires only four 0.1- μ F capacitors and features a logic-level output (READY) that asserts when the charge pump is regulating and the device is ready to begin transmitting.

The MAX3318 achieves a 1- μ A supply current using the auto-power-down feature. This device automatically enters a low-power power-down mode when the RS-232 cable is disconnected or the drivers of the connected peripherals are inactive for more than 30 s. The device turns on again when it senses a valid transition at any driver or receiver input. Auto power down saves power without changes to the existing BIOS or operating system.

This device is available in two space-saving packages: 20-pin SSOP and 20-pin TSSOP.



Please be aware that an important notice concerning availability, standard warranty, and use in critical applications of Texas Instruments semiconductor products and disclaimers thereto appears at the end of this data sheet.

MAX3318
2.5-V 460-kbps RS-232 TRANSCEIVER
WITH ± 15 -kV ESD PROTECTION

SLLS687–OCTOBER 2005

ORDERING INFORMATION

T _A	PACKAGE ⁽¹⁾		ORDERABLE PART NUMBER	TOP-SIDE MARKING
–0°C to 70°C	SSOP – DB	Tube of 70	MAX3318CDB	MA3318C
		Reel of 2000	MAX3318CDBR	
	TSSOP – PW	Tube of 70	MAX3318CPW	MA3318C
		Reel of 2000	MAX3318CPWR	
–40°C to 85°C	SSOP – DB	Tube of 70	MAX3318IDB	MA3318I
		Reel of 2000	MAX3318IDBR	
	TSSOP – PW	Tube of 70	MAX3318IPW	MA3318I
		Reel of 2000	MAX3318IPWR	

(1) Package drawings, standard packing quantities, thermal data, symbolization, and PCB design guidelines are available at www.ti.com/sc/package.

DETAILED DESCRIPTION

Flexible control options for power management are featured when the serial port and driver inputs are inactive. The auto-power-down plus feature functions when FORCEON is low and FORCEOFF is high. During this mode of operation, if the device does not sense valid signal transitions on all receiver and driver inputs for approximately 30 s, the built-in charge pump and drivers are powered down, reducing the supply current to 1 μ A. By disconnecting the serial port or placing the peripheral drivers off, auto-power-down plus can be disabled when FORCEON and FORCEOFF are high. With auto-power-down plus enabled, the device activates automatically when a valid signal is applied to any receiver or driver input. INVALID is high (valid data) if any receiver input voltage is greater than 2.7 V or less than –2.7 V, or has been between –0.3 V and 0.3 V for less than 30 μ s (typical number). INVALID is low (invalid data) if all receiver input voltage are between –0.3 V and 0.3 V for more than 30 μ s (typical number).

FUNCTION TABLE⁽¹⁾

INPUT CONDITIONS				OUTPUT STATES				OPERATING MODE
FORCEON	$\overline{\text{FORCEOFF}}$	RECEIVER OR DRIVER EDGE WITHIN 30 s	VALID RS-232 LEVEL PRESENT AT RECEIVER	DRIVER	RECEIVER	$\overline{\text{INVALID}}$	READY	
Auto-Power-Down Plus Conditions								
H	H	No	No	Active	Active	L	H	Normal operation, auto-power-down plus disabled
H	H	No	Yes	Active	Active	H	H	Normal operation, auto-power-down plus disabled
L	H	Yes	No	Active	Active	L	H	Normal operation, auto-power-down plus enabled
L	H	Yes	Yes	Active	Active	H	H	Normal operation, auto-power-down plus enabled
L	H	No	No	Z	Active	L	L	Power down, auto-power-down plus enabled
L	H	No	Yes	Z	Active	H	L	Power down, auto-power-down plus enabled
X	L	X	No	Z	Active	L	L	Manual power down
X	L	X	Yes	Z	Active	H	L	Manual power down
Auto-Power-Down Conditions								
$\overline{\text{INVALID}}$	$\overline{\text{INVALID}}$	X	No	Z	Active	L	L	Power down, auto power down enabled
$\overline{\text{INVALID}}$	$\overline{\text{INVALID}}$	X	Yes	Active	Active	H	H	Normal operation, auto power down enabled

(1) H = high level, L = low level, X = irrelevant, Z = high impedance

MAX3318
2.5-V 460-kbps RS-232 TRANSCEIVER
WITH ± 15 -kV ESD PROTECTION

SLLS687—OCTOBER 2005

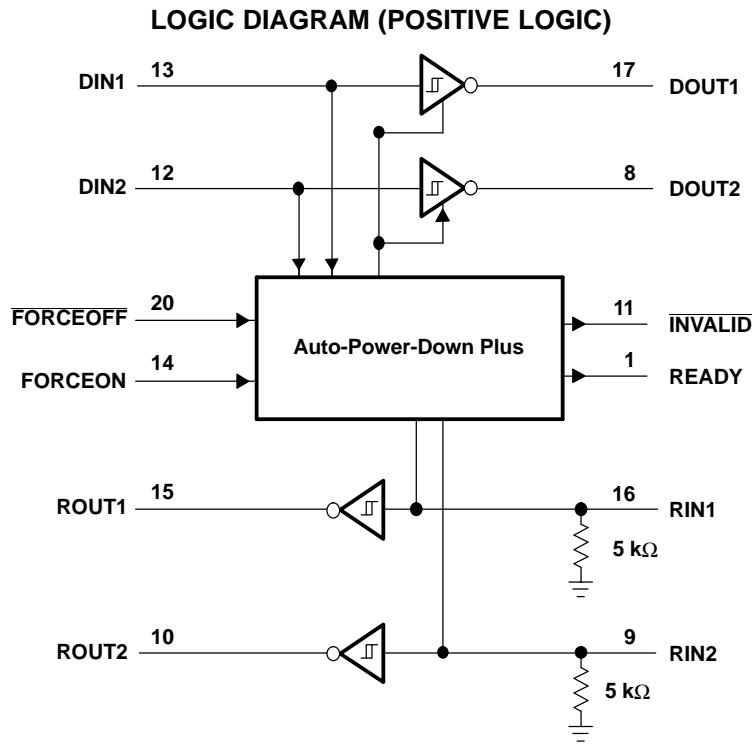

TERMINAL FUNCTIONS

TERMINAL		DESCRIPTION
NAME	NO.	
C1+	2	Positive voltage-doubler charge-pump capacitor
C1–	4	Negative voltage-doubler charge-pump capacitor
C2+	5	Positive inverting charge-pump capacitor
C2–	6	Negative inverting charge-pump capacitor
DIN	12, 13	CMOS driver inputs
DOUT	8, 17	RS-232 driver outputs
$\overline{\text{FORCEOFF}}$	20	Force-off input, active low. Drive low to power down transmitters, receivers, and charge pump. This overrides auto power down and FORCEON (see Function Table).
FORCEON	14	Force-on input, active high. Drive high to override auto power down, keeping transmitters and receivers on (FORCEOFF must be high) (see Function Table).
GND	18	Ground
$\overline{\text{INVALID}}$	11	Valid signal detector output, active low. A logic high indicates that a valid RS-232 level is present on a receiver input.
READY	1	Ready to transmit output, active high. READY is enabled high when V– goes below –3.5 V and the device is ready to transmit.
RIN	9, 16	RS-232 receiver inputs
ROUT	10, 15	CMOS receiver outputs
V+	3	$2 \times V_{\text{CC}}$ generated by the charge pump
V–	7	$-2 \times V_{\text{CC}}$ generated by the charge pump
V _{CC}	19	2.25-V to 3-V single-supply voltage

MAX3318
2.5-V 460-kbps RS-232 TRANSCEIVER
WITH ±15-kV ESD PROTECTION

SLLS687–OCTOBER 2005

Absolute Maximum Ratings⁽¹⁾

over operating free-air temperature range (unless otherwise noted)

		MIN	MAX	UNIT
V _{CC} to GND		-0.3	6	V
V+ to GND ⁽²⁾		-0.3	7	V
V- to GND ⁽²⁾		-7	0.3	V
V+ + IV-I ⁽²⁾			13	V
Input voltage	DIN, FORCEON, FORCEOFF to GND	-0.3	6	V
	RIN to GND		±25	
Output voltage	DOUT to GND		±13.2	V
	ROUT, INVALID, READY to GND	-0.3	V _{CC} + 0.3	
Short-circuit duration	DOUT to GND		Continuous	
Continuous power dissipation (T _A = 70°C)	16-pin SSOP (derate 7.14 mW/°C above 70°C)		571	mW
	20-pin SSOP (derate 8 mW/°C above 70°C)		640	
	20-pin TSSOP (derate 7 mW/°C above 70°C)		559	
Storage temperature range		-65	150	°C
Lead temperature (soldering, 10 s)			300	°C

- (1) Stresses beyond those listed under "absolute maximum ratings" may cause permanent damage to the device. These are stress ratings only, and functional operation of the device at these or any other conditions beyond those indicated under "recommended operating conditions" is not implied. Exposure to absolute-maximum-rated conditions for extended periods may affect device reliability.
- (2) V+ and V- can have maximum magnitudes of 7 V, but their absolute difference cannot exceed 13 V.

Recommended Operating Conditions

See Figure 4

			MIN	NOM	MAX	UNIT
Supply voltage			2.25	2.5	3	V
V _{IH}	Driver and control high-level input voltage	DIN, FORCEOFF, FORCEON V _{CC} = 2.5 V to 3 V	0.7 × V _{CC}		5.5	V
V _{IL}	Driver and control low-level input voltage	DIN, FORCEOFF, FORCEON V _{CC} = 2.5 V to 3 V	0		0.3 × V _{CC}	V
V _I	Receiver input voltage		-25		25	V
T _A	Operating free-air temperature	MAX3318C			70	°C
		MAX3318I			85	

Supply Current Section Electrical Characteristics
 $V_{CC} = 2.25\text{ V to }3\text{ V}$, $C1\text{--}C4 = 0.1\ \mu\text{F}$, $T_A = T_{MIN}$ to T_{MAX} (unless otherwise noted)

PARAMETER	TEST CONDITIONS	MIN	TYP ⁽¹⁾	MAX	UNIT
DC Characteristics ($V_{CC} = 2.5\text{ V}$, $T_A = 25^\circ\text{C}$)					
Auto-power-down plus supply current	FORCEON = GND, FORCEOFF = V_{CC} , All RIN and DIN idle		1	10	μA
Auto-power-down supply current	FORCEOFF = GND		1	10	μA
Supply current	FORCEON = FORCEOFF = V_{CC} , No load		0.3	2	mA

 (1) Typical values are at $V_{CC} = 2.5\text{ V}$, $T_A = 25^\circ\text{C}$.

ESD Protection

PARAMETER	TEST CONDITIONS	TYP	UNIT
RIN, DOUT	Human-Body Model (HBM)	± 15	kV
	IEC G1000-4-2 Air-Gap Discharge method	± 8	
	IEC G1000-4-2 Contact Discharge method	± 8	

MAX3318
2.5-V 460-kbps RS-232 TRANSCEIVER
WITH ± 15 -kV ESD PROTECTION

SLLS687–OCTOBER 2005

Driver Section Electrical Characteristics

over recommended ranges of supply voltage and operating free-air temperature,
 $V_{CC} = 2.25\text{ V to }3\text{ V}$, $C1\text{--}C4 = 0.1\ \mu\text{F}$, $T_A = T_{MIN}$ to T_{MAX} (unless otherwise noted) (see [Figure 4](#))

PARAMETER	TEST CONDITIONS	MIN	TYP ⁽¹⁾	MAX	UNIT
Driver input hysteresis			0.3		V
Input leakage current	FORCEON, DIN, $\overline{\text{FORCEOFF}}$		± 0.01	± 1	μA
Output voltage swing	All driver outputs loaded with 3 k Ω to ground	± 3.7	± 4		V
Output resistance	$V_{CC} = 0$, Driver output = $\pm 2\text{ V}$	300	10M		Ω
Output short-circuit current ⁽²⁾			± 25	± 60	mA
Output leakage current	$V_{CC} = 0$ or 2.25 V to 3 V, $V_{OUT} = \pm 12\text{ V}$, Drivers disabled			± 25	μA

- (1) Typical values are at $V_{CC} = 2.5\text{ V}$, $T_A = 25^\circ\text{C}$.
(2) Short-circuit durations should be controlled to prevent exceeding the device absolute power dissipation ratings, and not more than one output should be shorted at a time.

Driver Section Switching Characteristics

over recommended ranges of supply voltage and operating free-air temperature,
 $V_{CC} = 2.25\text{ V to }3\text{ V}$, $C1\text{--}C4 = 0.1\ \mu\text{F}$, $T_A = T_{MIN}$ to T_{MAX} (unless otherwise noted) (see [Figure 1](#))

PARAMETER	TEST CONDITIONS	MIN	TYP ⁽¹⁾	MAX	UNIT
Maximum data rate	$R_L = 3\text{ k}\Omega$, $C_L = 1000\text{ pF}$, One transmitter switching	460			kbps
$ t_{PHL} - t_{PLH} $ Driver skew ⁽²⁾			100		ns
Transition-region slew rate	$V_{CC} = 2.5\text{ V}$, $T_A = 25^\circ\text{C}$, $R_L = 3\text{ k}\Omega$ to 7 k Ω , Measured from 3 V to -3 V or -3 V to 3 V, $C_L = 150\text{ pF}$ to 2500 pF	4		30	V/ μs

- (1) Typical values are at $V_{CC} = 2.5\text{ V}$, $T_A = 25^\circ\text{C}$.
(2) Pulse skew is defined as $|t_{PLH} - t_{PHL}|$ of each channel of the same device.

Receiver Section Electrical Characteristics

over recommended ranges of supply voltage and operating free-air temperature,
 $V_{CC} = 2.25\text{ V to }3\text{ V}$, $C1\text{--}C4 = 0.1\ \mu\text{F}$, $T_A = T_{MIN}$ to T_{MAX} (unless otherwise noted) (see [Figure 4](#))

PARAMETER	TEST CONDITIONS	MIN	TYP ⁽¹⁾	MAX	UNIT
Input voltage range		-25		25	V
Input threshold low	$T_A = 25^\circ\text{C}$			$0.3 \times V_{CC}$	V
Input threshold high	$T_A = 25^\circ\text{C}$	$0.7 \times V_{CC}$			V
Input hysteresis			0.3		V
Input resistance	$T_A = 25^\circ\text{C}$	3	5	7	k Ω
Output leakage current			± 0.05	± 10	μA
Output voltage low	$I_{OUT} = 0.5\text{ mA}$			$0.1 \times V_{CC}$	V
Output voltage high	$I_{OUT} = -0.5\text{ mA}$	$0.9 \times V_{CC}$			V

(1) Typical values are at $V_{CC} = 2.5\text{ V}$, $T_A = 25^\circ\text{C}$.

Receiver Section Switching Characteristics

over recommended ranges of supply voltage and operating free-air temperature,
 $V_{CC} = 2.25\text{ V to }3\text{ V}$, $C1\text{--}C4 = 0.1\ \mu\text{F}$, $T_A = T_{MIN}$ to T_{MAX} (unless otherwise noted) (see [Figure 4](#))

PARAMETER	TEST CONDITIONS	TYP ⁽¹⁾	UNIT
t_{PHL}	Receiver propagation delay	RIN to ROUT, $C_L = 150\text{ pF}$	μs
t_{PLH}			
$ t_{PHL} - t_{PLH} $	Receiver skew ⁽²⁾	50	ns

(1) Typical values are at $V_{CC} = 2.5\text{ V}$, $T_A = 25^\circ\text{C}$.

(2) Pulse skew is defined as $|t_{PLH} - t_{PHL}|$ of each channel of the same device.

MAX3318
2.5-V 460-kbps RS-232 TRANSCEIVER
WITH ± 15 -kV ESD PROTECTION

SLLS687–OCTOBER 2005

Auto-Power-Down Plus Section Electrical Characteristics

over recommended ranges of supply voltage and operating free-air temperature,
 $V_{CC} = 2.25\text{ V to }3\text{ V}$, $C1\text{--}C4 = 0.1\text{ }\mu\text{F}$, $T_A = T_{MIN}$ to T_{MAX} (unless otherwise noted) (see [Figure 4](#))

PARAMETER	TEST CONDITIONS	MIN	MAX	UNIT
Receiver input threshold to $\overline{\text{INVALID}}$ high	Positive threshold		2.7	V
	Negative threshold	-2.7		
Receiver input threshold $\overline{\text{INVALID}}$ low		-0.3	0.3	V
$\overline{\text{INVALID}}$, READY voltage low	$I_{OUT} = 0.5\text{ mA}$		$0.1 \times V_{CC}$	V
$\overline{\text{INVALID}}$, READY voltage high	$I_{OUT} = -0.5\text{ mA}$	$0.8 \times V_{CC}$		V

Auto-Power-Down Plus Section Switching Characteristics

over recommended ranges of supply voltage and operating free-air temperature,
 $V_{CC} = 2.25\text{ V to }3\text{ V}$, $C1\text{--}C4 = 0.1\text{ }\mu\text{F}$, $T_A = T_{MIN}$ to T_{MAX} (unless otherwise noted) (see [Figure 4](#))

PARAMETER	TEST CONDITIONS	MIN	TYP ⁽¹⁾	MAX	UNIT
t_{INVH} Receiver positive or negative threshold to $\overline{\text{INVALID}}$ high	$V_{CC} = 2.5\text{ V}$		1		μs
t_{INVL} Receiver positive or negative threshold to $\overline{\text{INVALID}}$ low	$V_{CC} = 2.5\text{ V}$		30		μs
t_{WU} Receiver or driver edge to driver enabled	$V_{CC} = 2.5\text{ V}$		100		μs
$t_{AUTOPRDN}$ Receiver or driver edge to driver shutdown	$V_{CC} = 2.5\text{ V}$	15	30	60	s

(1) Typical values are at $V_{CC} = 2.5\text{ V}$, $T_A = 25^\circ\text{C}$.

PARAMETER MEASUREMENT INFORMATION

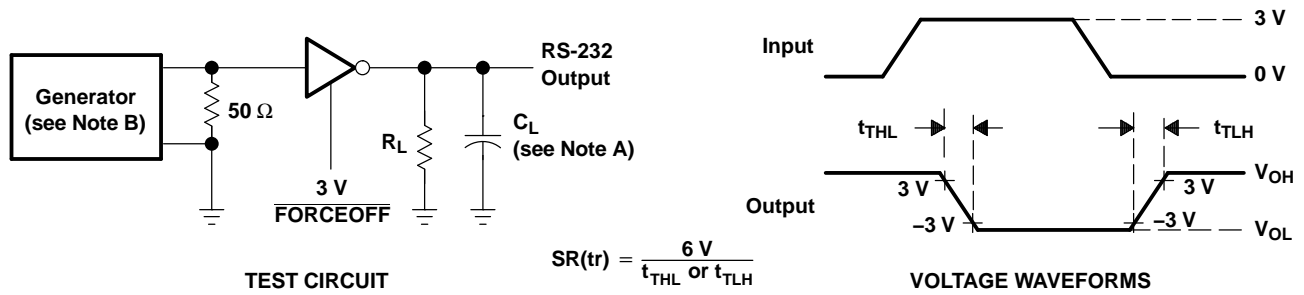

NOTES: A. C_L includes probe and jig capacitance.
 B. The pulse generator has the following characteristics: PRR = 250 kbit/s, $Z_O = 50\ \Omega$, 50% duty cycle, $t_r \leq 10\text{ ns}$, $t_f \leq 10\text{ ns}$.

Figure 1. Driver Slew Rate

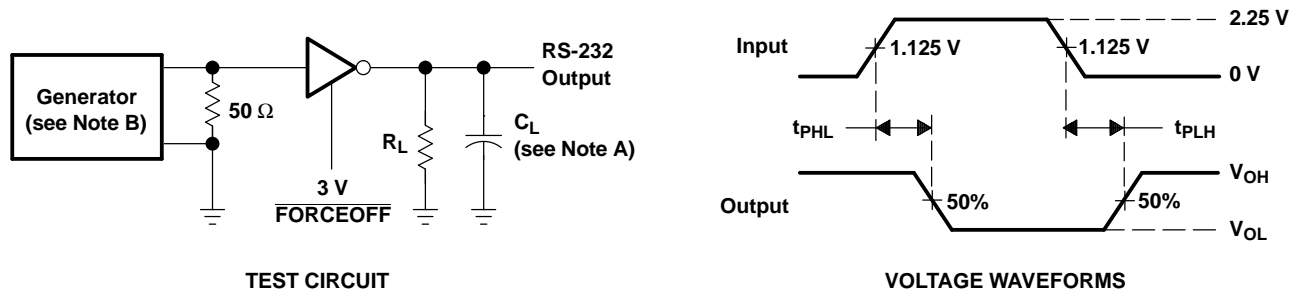

NOTES: A. C_L includes probe and jig capacitance.
 B. The pulse generator has the following characteristics: PRR = 250 kbit/s, $Z_O = 50\ \Omega$, 50% duty cycle, $t_r \leq 10\text{ ns}$, $t_f \leq 10\text{ ns}$.

Figure 2. Driver Pulse Skew

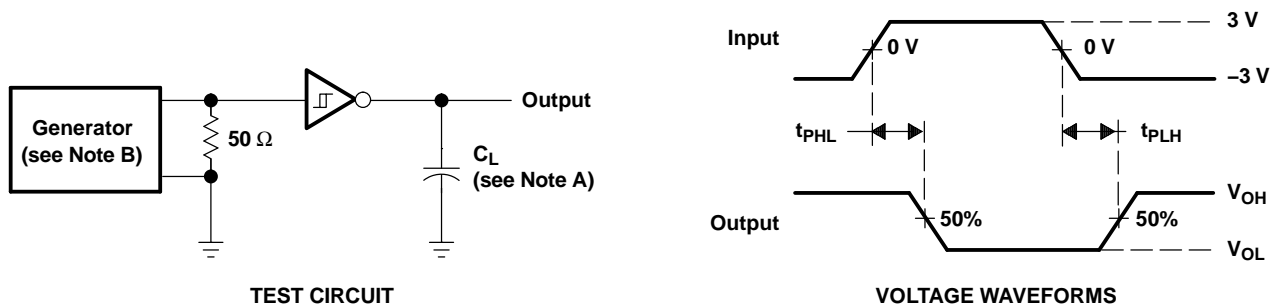

NOTES: A. C_L includes probe and jig capacitance.
 B. The pulse generator has the following characteristics: $Z_O = 50\ \Omega$, 50% duty cycle, $t_r \leq 10\text{ ns}$, $t_f \leq 10\text{ ns}$.

Figure 3. Receiver Propagation Delay Times

PARAMETER MEASUREMENT INFORMATION

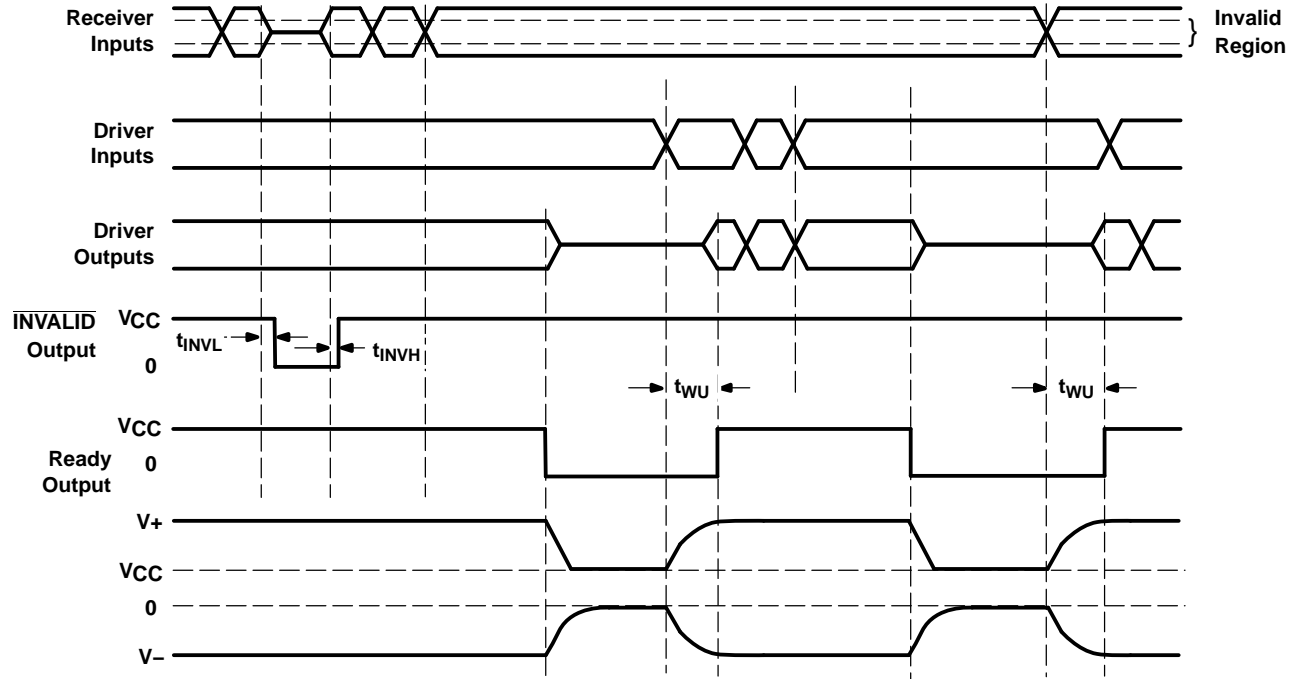

VOLTAGE WAVEFORMS

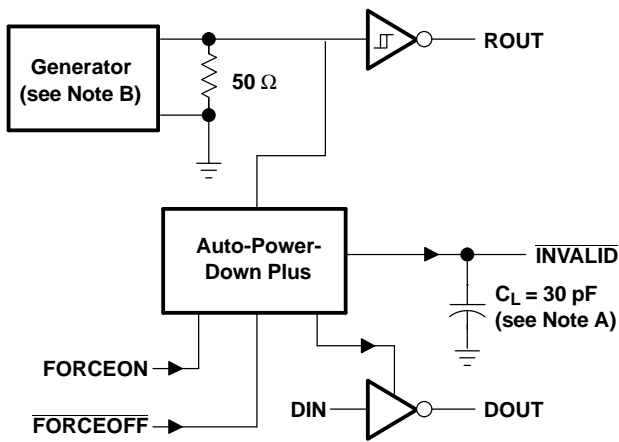

TEST CIRCUIT

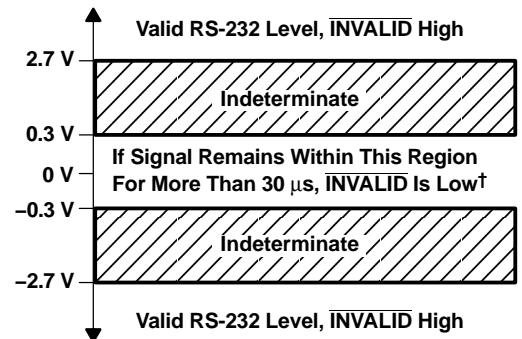

† Auto power down disables drivers and reduces supply current to 1 μ A.

Figure 4. $\overline{\text{INVALID}}$ Propagation Delay Times and Supply Enabling Time

PARAMETER MEASUREMENT INFORMATION

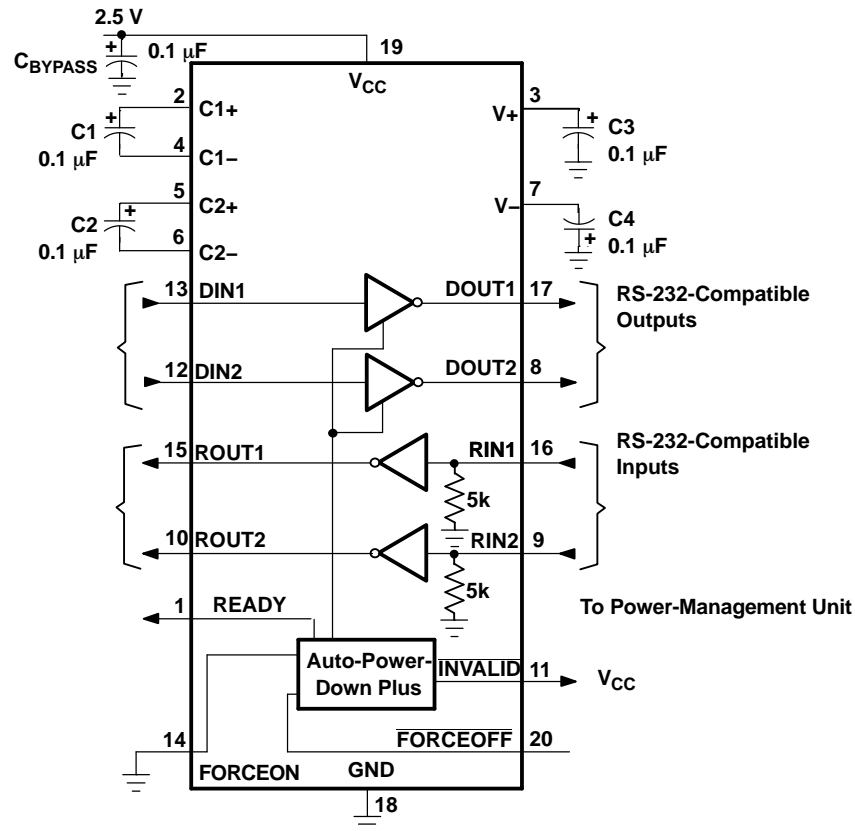

Figure 5. Typical Application Circuit

PACKAGING INFORMATION

Orderable Device	Status ⁽¹⁾	Package Type	Package Drawing	Pins	Package Qty	Eco Plan ⁽²⁾	Lead/Ball Finish	MSL Peak Temp ⁽³⁾
MAX3318CDB	ACTIVE	SSOP	DB	20	70	Green (RoHS & no Sb/Br)	CU NIPDAU	Level-1-260C-UNLIM
MAX3318CDBE4	ACTIVE	SSOP	DB	20	70	Green (RoHS & no Sb/Br)	CU NIPDAU	Level-1-260C-UNLIM
MAX3318CDBG4	ACTIVE	SSOP	DB	20	70	Green (RoHS & no Sb/Br)	CU NIPDAU	Level-1-260C-UNLIM
MAX3318CDBR	ACTIVE	SSOP	DB	20	2000	Green (RoHS & no Sb/Br)	CU NIPDAU	Level-1-260C-UNLIM
MAX3318CDBRE4	ACTIVE	SSOP	DB	20	2000	Green (RoHS & no Sb/Br)	CU NIPDAU	Level-1-260C-UNLIM
MAX3318CDBRG4	ACTIVE	SSOP	DB	20	2000	Green (RoHS & no Sb/Br)	CU NIPDAU	Level-1-260C-UNLIM
MAX3318CPW	ACTIVE	TSSOP	PW	20	70	Green (RoHS & no Sb/Br)	CU NIPDAU	Level-1-260C-UNLIM
MAX3318CPWE4	ACTIVE	TSSOP	PW	20	70	Green (RoHS & no Sb/Br)	CU NIPDAU	Level-1-260C-UNLIM
MAX3318CPWG4	ACTIVE	TSSOP	PW	20	70	Green (RoHS & no Sb/Br)	CU NIPDAU	Level-1-260C-UNLIM
MAX3318CPWR	ACTIVE	TSSOP	PW	20	2000	Green (RoHS & no Sb/Br)	CU NIPDAU	Level-1-260C-UNLIM
MAX3318CPWRE4	ACTIVE	TSSOP	PW	20	2000	Green (RoHS & no Sb/Br)	CU NIPDAU	Level-1-260C-UNLIM
MAX3318CPWRG4	ACTIVE	TSSOP	PW	20	2000	Green (RoHS & no Sb/Br)	CU NIPDAU	Level-1-260C-UNLIM
MAX3318IDB	ACTIVE	SSOP	DB	20	70	Green (RoHS & no Sb/Br)	CU NIPDAU	Level-1-260C-UNLIM
MAX3318IDBE4	ACTIVE	SSOP	DB	20	70	Green (RoHS & no Sb/Br)	CU NIPDAU	Level-1-260C-UNLIM
MAX3318IDBG4	ACTIVE	SSOP	DB	20	70	Green (RoHS & no Sb/Br)	CU NIPDAU	Level-1-260C-UNLIM
MAX3318IDBR	ACTIVE	SSOP	DB	20	2000	Green (RoHS & no Sb/Br)	CU NIPDAU	Level-1-260C-UNLIM
MAX3318IDBRE4	ACTIVE	SSOP	DB	20	2000	Green (RoHS & no Sb/Br)	CU NIPDAU	Level-1-260C-UNLIM
MAX3318IDBRG4	ACTIVE	SSOP	DB	20	2000	Green (RoHS & no Sb/Br)	CU NIPDAU	Level-1-260C-UNLIM
MAX3318IPW	ACTIVE	TSSOP	PW	20	70	Green (RoHS & no Sb/Br)	CU NIPDAU	Level-1-260C-UNLIM
MAX3318IPWE4	ACTIVE	TSSOP	PW	20	70	Green (RoHS & no Sb/Br)	CU NIPDAU	Level-1-260C-UNLIM
MAX3318IPWG4	ACTIVE	TSSOP	PW	20	70	Green (RoHS & no Sb/Br)	CU NIPDAU	Level-1-260C-UNLIM
MAX3318IPWR	ACTIVE	TSSOP	PW	20	2000	Green (RoHS & no Sb/Br)	CU NIPDAU	Level-1-260C-UNLIM
MAX3318IPWRE4	ACTIVE	TSSOP	PW	20	2000	Green (RoHS & no Sb/Br)	CU NIPDAU	Level-1-260C-UNLIM
MAX3318IPWRG4	ACTIVE	TSSOP	PW	20	2000	Green (RoHS & no Sb/Br)	CU NIPDAU	Level-1-260C-UNLIM

⁽¹⁾ The marketing status values are defined as follows:

ACTIVE: Product device recommended for new designs.

LIFEBUY: TI has announced that the device will be discontinued, and a lifetime-buy period is in effect.

NRND: Not recommended for new designs. Device is in production to support existing customers, but TI does not recommend using this part in a new design.

PREVIEW: Device has been announced but is not in production. Samples may or may not be available.

OBSOLETE: TI has discontinued the production of the device.

⁽²⁾ Eco Plan - The planned eco-friendly classification: Pb-Free (RoHS), Pb-Free (RoHS Exempt), or Green (RoHS & no Sb/Br) - please check <http://www.ti.com/productcontent> for the latest availability information and additional product content details.

TBD: The Pb-Free/Green conversion plan has not been defined.

Pb-Free (RoHS): TI's terms "Lead-Free" or "Pb-Free" mean semiconductor products that are compatible with the current RoHS requirements for all 6 substances, including the requirement that lead not exceed 0.1% by weight in homogeneous materials. Where designed to be soldered at high temperatures, TI Pb-Free products are suitable for use in specified lead-free processes.

Pb-Free (RoHS Exempt): This component has a RoHS exemption for either 1) lead-based flip-chip solder bumps used between the die and package, or 2) lead-based die adhesive used between the die and leadframe. The component is otherwise considered Pb-Free (RoHS compatible) as defined above.

Green (RoHS & no Sb/Br): TI defines "Green" to mean Pb-Free (RoHS compatible), and free of Bromine (Br) and Antimony (Sb) based flame retardants (Br or Sb do not exceed 0.1% by weight in homogeneous material)

⁽³⁾ MSL, Peak Temp. -- The Moisture Sensitivity Level rating according to the JEDEC industry standard classifications, and peak solder temperature.

Important Information and Disclaimer:The information provided on this page represents TI's knowledge and belief as of the date that it is provided. TI bases its knowledge and belief on information provided by third parties, and makes no representation or warranty as to the accuracy of such information. Efforts are underway to better integrate information from third parties. TI has taken and continues to take reasonable steps to provide representative and accurate information but may not have conducted destructive testing or chemical analysis on incoming materials and chemicals. TI and TI suppliers consider certain information to be proprietary, and thus CAS numbers and other limited information may not be available for release.

In no event shall TI's liability arising out of such information exceed the total purchase price of the TI part(s) at issue in this document sold by TI to Customer on an annual basis.

TAPE AND REEL BOX INFORMATION

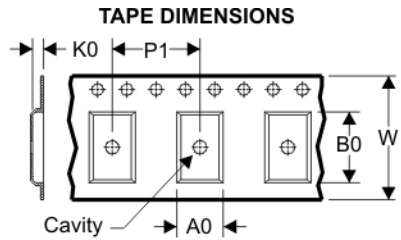
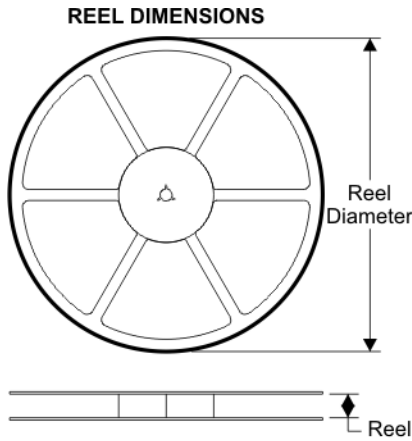

A0	Dimension designed to accommodate the component width
B0	Dimension designed to accommodate the component length
K0	Dimension designed to accommodate the component thickness
W	Overall width of the carrier tape
P1	Pitch between successive cavity centers

QUADRANT ASSIGNMENTS FOR PIN 1 ORIENTATION IN TAPE

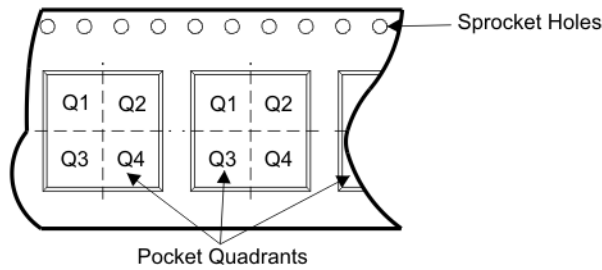

Device	Package	Pins	Site	Reel Diameter (mm)	Reel Width (mm)	A0 (mm)	B0 (mm)	K0 (mm)	P1 (mm)	W (mm)	Pin1 Quadrant
MAX3318CDBR	DB	20	SITE 41	330	16	8.2	7.5	2.5	12	16	Q1
MAX3318CPWR	PW	20	SITE 41	330	16	6.95	7.1	1.6	8	16	Q1
MAX3318IDBR	DB	20	SITE 41	330	16	8.2	7.5	2.5	12	16	Q1
MAX3318IPWR	PW	20	SITE 41	330	16	6.95	7.1	1.6	8	16	Q1

TAPE AND REEL BOX DIMENSIONS

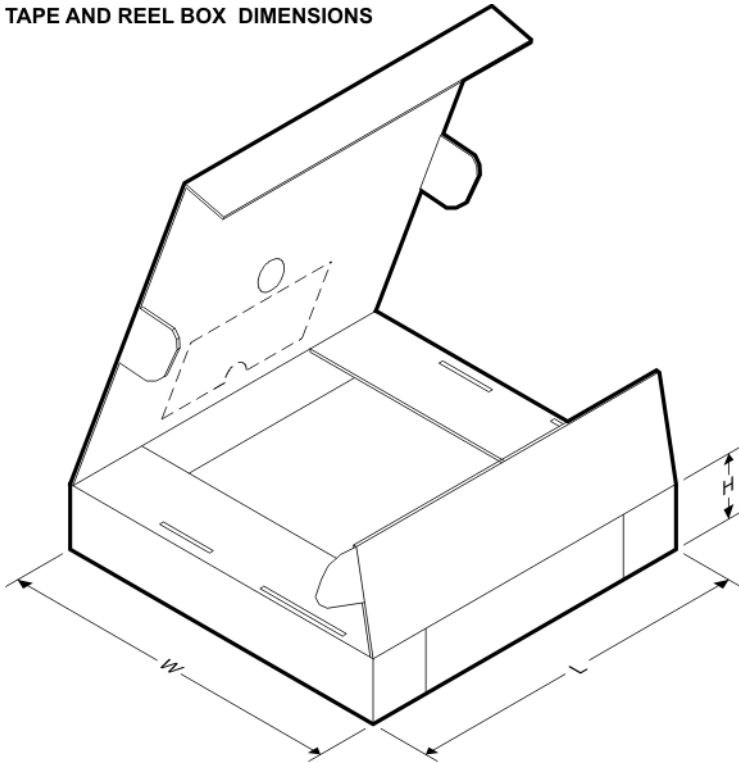

Device	Package	Pins	Site	Length (mm)	Width (mm)	Height (mm)
MAX3318CDBR	DB	20	SITE 41	346.0	346.0	33.0
MAX3318CPWR	PW	20	SITE 41	346.0	346.0	33.0
MAX3318IDBR	DB	20	SITE 41	346.0	346.0	33.0
MAX3318IPWR	PW	20	SITE 41	346.0	346.0	33.0

DB (R-PDSO-G**)

PLASTIC SMALL-OUTLINE

28 PINS SHOWN



- NOTES: A. All linear dimensions are in millimeters.
 B. This drawing is subject to change without notice.
 C. Body dimensions do not include mold flash or protrusion not to exceed 0,15.
 D. Falls within JEDEC MO-150

PW (R-PDSO-G**)

PLASTIC SMALL-OUTLINE PACKAGE

14 PINS SHOWN



4040064/F 01/97

- NOTES: A. All linear dimensions are in millimeters.
 B. This drawing is subject to change without notice.
 C. Body dimensions do not include mold flash or protrusion not to exceed 0,15.
 D. Falls within JEDEC MO-153

IMPORTANT NOTICE

Texas Instruments Incorporated and its subsidiaries (TI) reserve the right to make corrections, modifications, enhancements, improvements, and other changes to its products and services at any time and to discontinue any product or service without notice. Customers should obtain the latest relevant information before placing orders and should verify that such information is current and complete. All products are sold subject to TI's terms and conditions of sale supplied at the time of order acknowledgment.

TI warrants performance of its hardware products to the specifications applicable at the time of sale in accordance with TI's standard warranty. Testing and other quality control techniques are used to the extent TI deems necessary to support this warranty. Except where mandated by government requirements, testing of all parameters of each product is not necessarily performed.

TI assumes no liability for applications assistance or customer product design. Customers are responsible for their products and applications using TI components. To minimize the risks associated with customer products and applications, customers should provide adequate design and operating safeguards.

TI does not warrant or represent that any license, either express or implied, is granted under any TI patent right, copyright, mask work right, or other TI intellectual property right relating to any combination, machine, or process in which TI products or services are used. Information published by TI regarding third-party products or services does not constitute a license from TI to use such products or services or a warranty or endorsement thereof. Use of such information may require a license from a third party under the patents or other intellectual property of the third party, or a license from TI under the patents or other intellectual property of TI.

Reproduction of TI information in TI data books or data sheets is permissible only if reproduction is without alteration and is accompanied by all associated warranties, conditions, limitations, and notices. Reproduction of this information with alteration is an unfair and deceptive business practice. TI is not responsible or liable for such altered documentation. Information of third parties may be subject to additional restrictions.

Resale of TI products or services with statements different from or beyond the parameters stated by TI for that product or service voids all express and any implied warranties for the associated TI product or service and is an unfair and deceptive business practice. TI is not responsible or liable for any such statements.

TI products are not authorized for use in safety-critical applications (such as life support) where a failure of the TI product would reasonably be expected to cause severe personal injury or death, unless officers of the parties have executed an agreement specifically governing such use. Buyers represent that they have all necessary expertise in the safety and regulatory ramifications of their applications, and acknowledge and agree that they are solely responsible for all legal, regulatory and safety-related requirements concerning their products and any use of TI products in such safety-critical applications, notwithstanding any applications-related information or support that may be provided by TI. Further, Buyers must fully indemnify TI and its representatives against any damages arising out of the use of TI products in such safety-critical applications.

TI products are neither designed nor intended for use in military/aerospace applications or environments unless the TI products are specifically designated by TI as military-grade or "enhanced plastic." Only products designated by TI as military-grade meet military specifications. Buyers acknowledge and agree that any such use of TI products which TI has not designated as military-grade is solely at the Buyer's risk, and that they are solely responsible for compliance with all legal and regulatory requirements in connection with such use.

TI products are neither designed nor intended for use in automotive applications or environments unless the specific TI products are designated by TI as compliant with ISO/TS 16949 requirements. Buyers acknowledge and agree that, if they use any non-designated products in automotive applications, TI will not be responsible for any failure to meet such requirements.

Following are URLs where you can obtain information on other Texas Instruments products and application solutions:

Products		Applications	
Amplifiers	amplifier.ti.com	Audio	www.ti.com/audio
Data Converters	dataconverter.ti.com	Automotive	www.ti.com/automotive
DSP	dsp.ti.com	Broadband	www.ti.com/broadband
Interface	interface.ti.com	Digital Control	www.ti.com/digitalcontrol
Logic	logic.ti.com	Military	www.ti.com/military
Power Mgmt	power.ti.com	Optical Networking	www.ti.com/opticalnetwork
Microcontrollers	microcontroller.ti.com	Security	www.ti.com/security
RFID	www.ti-rfid.com	Telephony	www.ti.com/telephony
Low Power Wireless	www.ti.com/lpw	Video & Imaging	www.ti.com/video
		Wireless	www.ti.com/wireless

Mailing Address: Texas Instruments, Post Office Box 655303, Dallas, Texas 75265
Copyright © 2007, Texas Instruments Incorporated