

# 3-V TO 5.5-V MULTICHANNEL RS-232 LINE DRIVER/RECEIVER WITH $\pm 15$ -kV ESD (HBM) PROTECTION

SLLS350L – APRIL 1999 – REVISED MARCH 2004

- **Single-Chip and Single-Supply Interface for IBM™ PC/AT™ Serial Port**
- **RS-232 Bus-Pin ESD Protection Exceeds  $\pm 15$  kV Using Human-Body Model (HBM)**
- **Meets or Exceeds the Requirements of TIA/EIA-232-F and ITU v.28 Standards**
- **Operates With 3-V to 5.5-V  $V_{CC}$  Supply**
- **Three Drivers and Five Receivers**
- **Operates Up To 250 kbit/s**
- **Designed to Transmit at a Data Rate of 250 kbit/s**
- **Low Standby Current . . . 1  $\mu$ A Typical**
- **External Capacitors . . .  $4 \times 0.1 \mu$ F**
- **Accepts 5-V Logic Input With 3.3-V Supply**
- **Always-Active Noninverting Receiver Output (ROUT2B)**
- **Alternative High-Speed Pin-Compatible Device (1 Mbit/s)**
  - SNx5C3243
- **Serial-Mouse Driveability**
- **Auto-Powerdown Feature to Disable Driver Outputs When No Valid RS-232 Signal Is Sensed**
- **Applications**
  - Battery-Powered Systems, PDAs, Notebooks, Laptops, Palmtop PCs, and Hand-Held Equipment

DB, DW, OR PW PACKAGE  
(TOP VIEW)

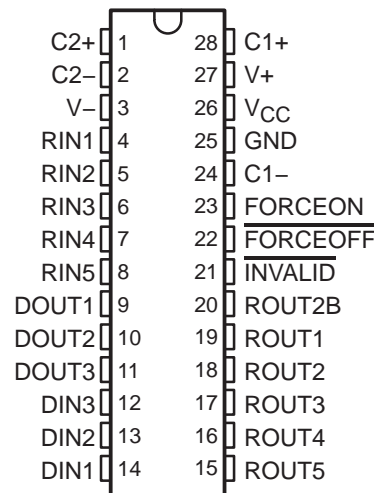

## description/ordering information

The MAX3243 consists of three line drivers, five line receivers, and a dual charge-pump circuit with  $\pm 15$ -kV ESD (HBM) protection pin to pin (serial-port connection pins, including GND). The device meets the requirements of TIA/EIA-232-F and provides the electrical interface between an asynchronous communication controller and the serial-port connector. This combination of drivers and receivers matches that needed for the typical serial port used in an IBM PC/AT, or compatible. The charge pump and four small external capacitors allow operation from a single 3-V to 5.5-V supply. In addition, the device includes an always-active noninverting output (ROUT2B), which allows applications using the ring indicator to transmit data while the device is powered down. The device operates at data signaling rates up to 250 kbit/s and a maximum of 30-V/ $\mu$ s driver output slew rate.



Please be aware that an important notice concerning availability, standard warranty, and use in critical applications of Texas Instruments semiconductor products and disclaimers thereto appears at the end of this data sheet.

AT, IBM, and PC are trademarks of International Business Machines Corporation.

PRODUCTION DATA information is current as of publication date. Products conform to specifications per the terms of Texas Instruments standard warranty. Production processing does not necessarily include testing of all parameters.

 **TEXAS  
INSTRUMENTS**

POST OFFICE BOX 655303 • DALLAS, TEXAS 75265

Copyright © 2004, Texas Instruments Incorporated

# MAX3243

## 3-V TO 5.5-V MULTICHANNEL RS-232 LINE DRIVER/RECEIVER

### WITH $\pm 15$ -kV ESD (HBM) PROTECTION

SLLS350L – APRIL 1999 – REVISED MARCH 2004

#### description/ordering information (continued)

Flexible control options for power management are available when the serial port is inactive. The auto-powerdown feature functions when FORCEON is low and  $\overline{\text{FORCEOFF}}$  is high. During this mode of operation, if the device does not sense a valid RS-232 signal, the driver outputs are disabled. If  $\overline{\text{FORCEOFF}}$  is set low, both drivers and receivers (except ROUT2B) are shut off, and the supply current is reduced to 1  $\mu\text{A}$ . Disconnecting the serial port or turning off the peripheral drivers causes the auto-powerdown condition to occur.

Auto-powerdown can be disabled when FORCEON and  $\overline{\text{FORCEOFF}}$  are high and should be done when driving a serial mouse. With auto-powerdown enabled, the device is activated automatically when a valid signal is applied to any receiver input. The  $\overline{\text{INVALID}}$  output is used to notify the user if an RS-232 signal is present at any receiver input.  $\overline{\text{INVALID}}$  is high (valid data) if any receiver input voltage is greater than 2.7 V or less than -2.7 V or has been between -0.3 V and 0.3 V for less than 30  $\mu\text{s}$ .  $\overline{\text{INVALID}}$  is low (invalid data) if all receiver input voltages are between -0.3 V and 0.3 V for more than 30  $\mu\text{s}$ . Refer to Figure 5 for receiver input levels.

#### ORDERING INFORMATION

TA	PACKAGE†		ORDERABLE PART NUMBER	TOP-SIDE MARKING
0°C to 70°C	SOIC (DW)	Tube of 20	MAX3243CDW	MAX3243C
		Reel of 1000	MAX3243CDWR	
	SSOP (DB)	Tube of 50	MAX3243CDB	MAX3243C
		Reel of 2000	MAX3243CDBR	
	TSSOP (PW)	Tube of 50	MAX3243CPW	MA3243C
		Reel of 2000	MAX3243CPWR	
-40°C to 85°C	SOIC (DW)	Tube of 20	MAX3243IDW	MAX3243I
		Reel of 1000	MAX3243IDWR	
	SSOP (DB)	Tube of 50	MAX3243IDB	MAX3243I
		Reel of 2000	MAX3243IDBR	
	TSSOP (PW)	Tube of 50	MAX3243IPW	MB3243I
		Reel of 2000	MAX3243IPWR	

† Package drawings, standard packing quantities, thermal data, symbolization, and PCB design guidelines are available at [www.ti.com/sc/package](http://www.ti.com/sc/package).

#### Function Tables

##### EACH DRIVER

INPUTS				OUTPUT DOUT	DRIVER STATUS
DIN	FORCEON	$\overline{\text{FORCEOFF}}$	VALID RIN RS-232 LEVEL		
X	X	L	X	Z	Powered off
L	H	H	X	H	Normal operation with auto-powerdown disabled
H	H	H	X	L	
L	L	H	Yes	H	Normal operation with auto-powerdown enabled
H	L	H	Yes	L	
L	L	H	No	Z	Powered off by auto-powerdown feature
H	L	H	No	Z	

H = high level, L = low level, X = irrelevant, Z = high impedance



**MAX3243**  
**3-V TO 5.5-V MULTICHANNEL RS-232 LINE DRIVER/RECEIVER**  
**WITH  $\pm 15$ -kV ESD (HBM) PROTECTION**

SLLS350L – APRIL 1999 – REVISED MARCH 2004

EACH RECEIVER

INPUTS				OUTPUTS		RECEIVER STATUS
RIN2	RIN1, RIN3-RIN5	$\overline{\text{FORCEOFF}}$	VALID RIN RS-232 LEVEL	ROUT2B	ROUT	
L	X	L	X	L	Z	Powered off while ROUT2B is active
H	X	L	X	H	Z	
L	L	H	Yes	L	H	Normal operation with auto-powerdown disabled/enabled
L	H	H	Yes	L	L	
H	L	H	Yes	H	H	
H	H	H	Yes	H	L	
Open	Open	H	No	L	H	

H = high level, L = low level, X = irrelevant, Z = high impedance (off), Open = input disconnected or connected driver off

**logic diagram (positive logic)**

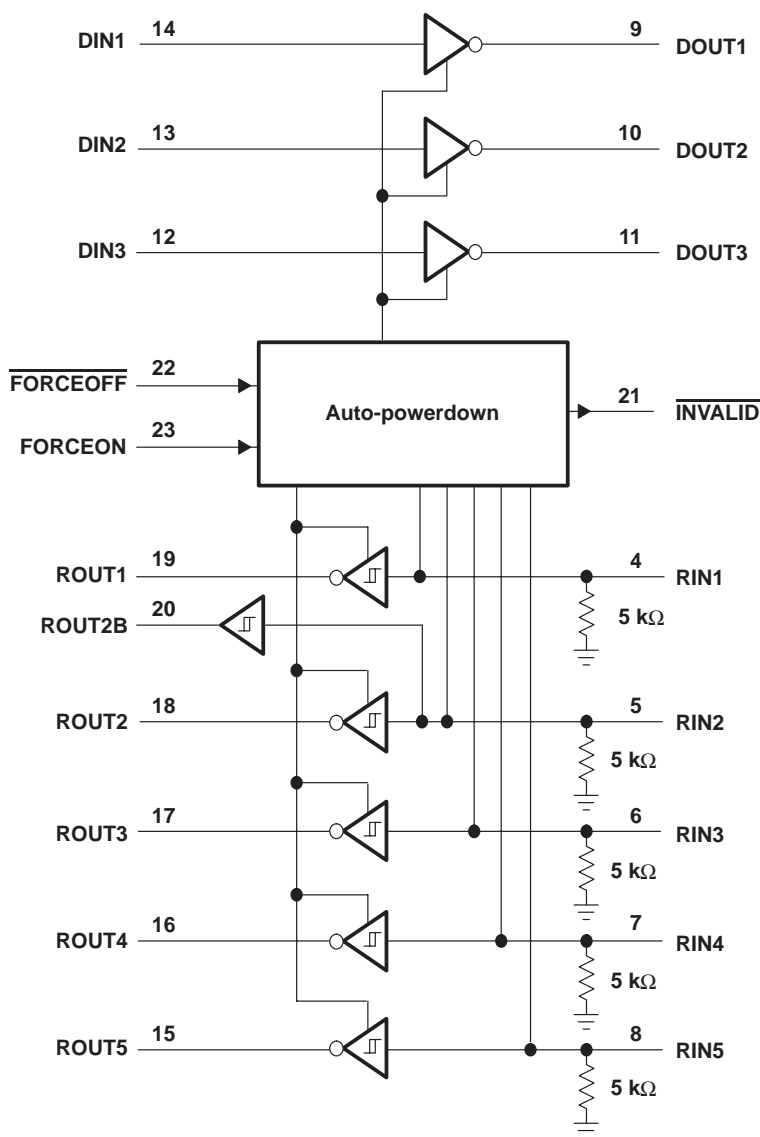

# MAX3243

## 3-V TO 5.5-V MULTICHANNEL RS-232 LINE DRIVER/RECEIVER

### WITH ±15-kV ESD (HBM) PROTECTION

SLLS350L – APRIL 1999 – REVISED MARCH 2004

#### absolute maximum ratings over operating free-air temperature range (unless otherwise noted)†

Supply voltage range, $V_{CC}$ (see Note 1)	–0.3 V to 6 V
Positive output supply voltage range, $V+$ (see Note 1)	–0.3 V to 7 V
Negative output supply voltage range, $V-$ (see Note 1)	0.3 V to –7 V
Supply voltage difference, $V+ - V-$ (see Note 1)	13 V
Input voltage range, $V_I$ : Driver ( $\overline{\text{FORCEOFF}}$ , FORCEON)	–0.3 V to 6 V
Receiver	–25 V to 25 V
Output voltage range, $V_O$ : Driver	–13.2 V to 13.2 V
Receiver (INVALID)	–0.3 V to $V_{CC} + 0.3$ V
Package thermal impedance, $\theta_{JA}$ (see Notes 2 and 3): DB package	62°C/W
DW package	46°C/W
PW package	62°C/W
Operating virtual junction temperature, $T_J$	150°C
Storage temperature range, $T_{stg}$	–65°C to 150°C

† Stresses beyond those listed under “absolute maximum ratings” may cause permanent damage to the device. These are stress ratings only, and functional operation of the device at these or any other conditions beyond those indicated under “recommended operating conditions” is not implied. Exposure to absolute-maximum-rated conditions for extended periods may affect device reliability.

- NOTES: 1. All voltages are with respect to network GND.  
 2. Maximum power dissipation is a function of  $T_{J(max)}$ ,  $\theta_{JA}$ , and  $T_A$ . The maximum allowable power dissipation at any allowable ambient temperature is  $P_D = (T_{J(max)} - T_A)/\theta_{JA}$ . Operating at the absolute maximum  $T_J$  of 150°C can affect reliability.  
 3. The package thermal impedance is calculated in accordance with JESD 51-7.

#### recommended operating conditions (see Note 4 and Figure 6)

			MIN	NOM	MAX	UNIT
Supply voltage		$V_{CC} = 3.3$ V	3	3.3	3.6	V
		$V_{CC} = 5$ V	4.5	5	5.5	
$V_{IH}$ Driver and control high-level input voltage	DIN, $\overline{\text{FORCEOFF}}$ , FORCEON	$V_{CC} = 3.3$ V	2		V	
		$V_{CC} = 5$ V	2.4			
$V_{IL}$ Driver and control low-level input voltage	DIN, $\overline{\text{FORCEOFF}}$ , FORCEON			0.8	V	
$V_I$ Driver and control input voltage	DIN, $\overline{\text{FORCEOFF}}$ , FORCEON		0	5.5	V	
$V_I$ Receiver input voltage			–25	25	V	
$T_A$ Operating free-air temperature		MAX3243C	0	70	°C	
		MAX3243I	–40	85		

NOTE 4: Test conditions are C1–C4 = 0.1  $\mu$ F at  $V_{CC} = 3.3$  V  $\pm$  0.3 V; C1 = 0.047  $\mu$ F, C2–C4 = 0.33  $\mu$ F at  $V_{CC} = 5$  V  $\pm$  0.5 V.

#### electrical characteristics over recommended ranges of supply voltage and operating free-air temperature (unless otherwise noted) (see Note 4 and Figure 6)

PARAMETER		TEST CONDITIONS		MIN	TYP‡	MAX	UNIT
$I_I$	Input leakage current	$\overline{\text{FORCEOFF}}$ , FORCEON			$\pm 0.01$	$\pm 1$	$\mu$ A
$I_{CC}$	Supply current	Auto-powerdown disabled	No load, $\overline{\text{FORCEOFF}}$ and FORCEON at $V_{CC}$		0.3	1	mA
		Powered off	$V_{CC} = 3.3$ V or 5 V, $T_A = 25^\circ\text{C}$		1	10	
		Auto-powerdown enabled	No load, $\overline{\text{FORCEOFF}}$ at $V_{CC}$ , FORCEON at GND, All RIN are open or grounded, All DIN are grounded		1	10	$\mu$ A

‡ All typical values are at  $V_{CC} = 3.3$  V or  $V_{CC} = 5$  V, and  $T_A = 25^\circ\text{C}$ .

NOTE 4: Test conditions are C1–C4 = 0.1  $\mu$ F at  $V_{CC} = 3.3$  V  $\pm$  0.3 V; C1 = 0.047  $\mu$ F, C2–C4 = 0.33  $\mu$ F at  $V_{CC} = 5$  V  $\pm$  0.5 V.



**MAX3243**  
**3-V TO 5.5-V MULTICHANNEL RS-232 LINE DRIVER/RECEIVER**  
**WITH ±15-kV ESD (HBM) PROTECTION**

SLLS350L – APRIL 1999 – REVISED MARCH 2004

**DRIVER SECTION**

**electrical characteristics over recommended ranges of supply voltage and operating free-air temperature (unless otherwise noted) (see Note 4 and Figure 6)**

PARAMETER		TEST CONDITIONS	MIN	TYP†	MAX	UNIT
V <sub>OH</sub>	High-level output voltage	All DOUT at R <sub>L</sub> = 3 kΩ to GND	5	5.4		V
V <sub>OL</sub>	Low-level output voltage	All DOUT at R <sub>L</sub> = 3 kΩ to GND	-5	-5.4		V
V <sub>O</sub>	Output voltage (mouse driveability)	DIN1 = DIN2 = GND, DIN3 = V <sub>CC</sub> , 3-kΩ to GND at DOUT3, DOUT1 = DOUT2 = 2.5 mA	±5			V
I <sub>IH</sub>	High-level input current	V <sub>I</sub> = V <sub>CC</sub>		±0.01	±1	μA
I <sub>IL</sub>	Low-level input current	V <sub>I</sub> at GND		±0.01	±1	μA
I <sub>OS</sub>	Short-circuit output current‡	V <sub>CC</sub> = 3.6 V, V <sub>O</sub> = 0 V V <sub>CC</sub> = 5.5 V, V <sub>O</sub> = 0 V		±35	±60	mA
r <sub>o</sub>	Output resistance	V <sub>CC</sub> , V+, and V- = 0 V, V <sub>O</sub> = ±2 V	300	10M		Ω
I <sub>off</sub>	Output leakage current	$\overline{\text{FORCEOFF}} = \text{GND}$ V <sub>O</sub> = ±12 V, V <sub>CC</sub> = 3 V to 3.6 V V <sub>O</sub> = ±10 V, V <sub>CC</sub> = 4.5 V to 5.5 V			±25 ±25	μA

† All typical values are at V<sub>CC</sub> = 3.3 V or V<sub>CC</sub> = 5 V, and T<sub>A</sub> = 25°C.

‡ Short-circuit durations should be controlled to prevent exceeding the device absolute power dissipation ratings, and not more than one output should be shorted at a time.

NOTE 4: Test conditions are C1–C4 = 0.1 μF at V<sub>CC</sub> = 3.3 V ± 0.3 V; C1 = 0.047 μF, C2–C4 = 0.33 μF at V<sub>CC</sub> = 5 V ± 0.5 V.

**switching characteristics over recommended ranges of supply voltage and operating free-air temperature (unless otherwise noted) (see Note 4 and Figure 6)**

PARAMETER		TEST CONDITIONS	MIN	TYP†	MAX	UNIT
Maximum data rate		C <sub>L</sub> = 1000 pF, One DOUT switching, R <sub>L</sub> = 3 kΩ, See Figure 1	150	250		kbit/s
t <sub>sk(p)</sub>	Pulse skew§	C <sub>L</sub> = 150 pF to 2500 pF, R <sub>L</sub> = 3 kΩ to 7 kΩ, See Figure 2		100		ns
SR(tr)	Slew rate, transition region (see Figure 1)	V <sub>CC</sub> = 3.3 V, R <sub>L</sub> = 3 kΩ to 7 kΩ, C <sub>L</sub> = 150 pF to 1000 pF	6		30	V/μs
		C <sub>L</sub> = 150 pF to 2500 pF	4		30	

† All typical values are at V<sub>CC</sub> = 3.3 V or V<sub>CC</sub> = 5 V, and T<sub>A</sub> = 25°C.

§ Pulse skew is defined as |t<sub>pLH</sub> - t<sub>pHL</sub>| of each channel of the same device.

NOTE 4: Test conditions are C1–C4 = 0.1 μF at V<sub>CC</sub> = 3.3 V ± 0.3 V; C1 = 0.047 μF, C2–C4 = 0.33 μF at V<sub>CC</sub> = 5 V ± 0.5 V.



**MAX3243****3-V TO 5.5-V MULTICHANNEL RS-232 LINE DRIVER/RECEIVER  
WITH  $\pm 15$ -kV ESD (HBM) PROTECTION**

SLLS350L – APRIL 1999 – REVISED MARCH 2004

**RECEIVER SECTION****electrical characteristics over recommended ranges of supply voltage and operating free-air temperature (unless otherwise noted) (see Note 4 and Figure 6)**

PARAMETER		TEST CONDITIONS	MIN	TYP†	MAX	UNIT
V <sub>OH</sub>	High-level output voltage	I <sub>OH</sub> = -1 mA	V <sub>CC</sub> -0.6 V	V <sub>CC</sub> -0.1 V		V
V <sub>OL</sub>	Low-level output voltage	I <sub>OL</sub> = 1.6 mA			0.4	V
V <sub>IT+</sub>	Positive-going input threshold voltage	V <sub>CC</sub> = 3.3 V		1.6	2.4	V
		V <sub>CC</sub> = 5 V		1.9	2.4	
V <sub>IT-</sub>	Negative-going input threshold voltage	V <sub>CC</sub> = 3.3 V	0.6	1.1		V
		V <sub>CC</sub> = 5 V	0.8	1.4		
V <sub>hys</sub>	Input hysteresis (V <sub>IT+</sub> - V <sub>IT-</sub> )			0.5		V
I <sub>off</sub>	Output leakage current (except ROUT2B)	FORCEOFF = 0 V		±0.05	±10	µA
r <sub>i</sub>	Input resistance	V <sub>I</sub> = ±3 V to ±25 V	3	5	7	kΩ

† All typical values are at V<sub>CC</sub> = 3.3 V or V<sub>CC</sub> = 5 V, and T<sub>A</sub> = 25°C.NOTE 4: Test conditions are C1-C4 = 0.1 µF at V<sub>CC</sub> = 3.3 V ± 0.3 V; C1 = 0.047 µF, C2-C4 = 0.33 µF at V<sub>CC</sub> = 5 V ± 0.5 V.**switching characteristics over recommended ranges of supply voltage and operating free-air temperature (unless otherwise noted) (see Note 4)**

PARAMETER		TEST CONDITIONS	MIN	TYP†	MAX	UNIT
t <sub>PLH</sub>	Propagation delay time, low- to high-level output	C <sub>L</sub> = 150 pF, See Figure 3		150		ns
t <sub>PHL</sub>	Propagation delay time, high- to low-level output			150		ns
t <sub>en</sub>	Output enable time	C <sub>L</sub> = 150 pF, R <sub>L</sub> = 3 kΩ, See Figure 4		200		ns
t <sub>dis</sub>	Output disable time			200		ns
t <sub>sk(p)</sub>	Pulse skew‡	See Figure 3		50		ns

† All typical values are at V<sub>CC</sub> = 3.3 V or V<sub>CC</sub> = 5 V, and T<sub>A</sub> = 25°C.‡ Pulse skew is defined as |t<sub>PLH</sub> - t<sub>PHL</sub>| of each channel of the same device.NOTE 4: Test conditions are C1-C4 = 0.1 µF at V<sub>CC</sub> = 3.3 V ± 0.3 V; C1 = 0.047 µF, C2-C4 = 0.33 µF at V<sub>CC</sub> = 5 V ± 0.5 V.

**MAX3243**  
**3-V TO 5.5-V MULTICHANNEL RS-232 LINE DRIVER/RECEIVER**  
**WITH ±15-kV ESD (HBM) PROTECTION**

SLLS350L – APRIL 1999 – REVISED MARCH 2004

**AUTO-POWERDOWN SECTION**

electrical characteristics over recommended ranges of supply voltage and operating free-air temperature (unless otherwise noted) (see Figure 5)

PARAMETER		TEST CONDITIONS	MIN	TYP†	MAX	UNIT
$V_{T+}(\text{valid})$	Receiver input threshold for INVALID high-level output voltage	$\overline{\text{FORCEON}} = \text{GND}$ , $\overline{\text{FORCEOFF}} = V_{CC}$			2.7	V
$V_{T-}(\text{valid})$	Receiver input threshold for INVALID high-level output voltage	$\overline{\text{FORCEON}} = \text{GND}$ , $\overline{\text{FORCEOFF}} = V_{CC}$	-2.7			V
$V_{T}(\text{invalid})$	Receiver input threshold for INVALID low-level output voltage	$\overline{\text{FORCEON}} = \text{GND}$ , $\overline{\text{FORCEOFF}} = V_{CC}$	-0.3		0.3	V
$V_{OH}$	$\overline{\text{INVALID}}$ high-level output voltage	$I_{OH} = -1 \text{ mA}$ , $\overline{\text{FORCEON}} = \text{GND}$ , $\overline{\text{FORCEOFF}} = V_{CC}$	$V_{CC}-0.6$			V
$V_{OL}$	$\overline{\text{INVALID}}$ low-level output voltage	$I_{OL} = 1.6 \text{ mA}$ , $\overline{\text{FORCEON}} = \text{GND}$ , $\overline{\text{FORCEOFF}} = V_{CC}$			0.4	V

† All typical values are at  $V_{CC} = 3.3 \text{ V}$  or  $V_{CC} = 5 \text{ V}$ , and  $T_A = 25^\circ\text{C}$ .

switching characteristics over recommended ranges of supply voltage and operating free-air temperature (unless otherwise noted) (see Figure 5)

PARAMETER		MIN	TYP†	MAX	UNIT
$t_{\text{valid}}$	Propagation delay time, low- to high-level output		1		$\mu\text{s}$
$t_{\text{invalid}}$	Propagation delay time, high- to low-level output		30		$\mu\text{s}$
$t_{\text{en}}$	Supply enable time		100		$\mu\text{s}$

† All typical values are at  $V_{CC} = 3.3 \text{ V}$  or  $V_{CC} = 5 \text{ V}$ , and  $T_A = 25^\circ\text{C}$ .

**PARAMETER MEASUREMENT INFORMATION**

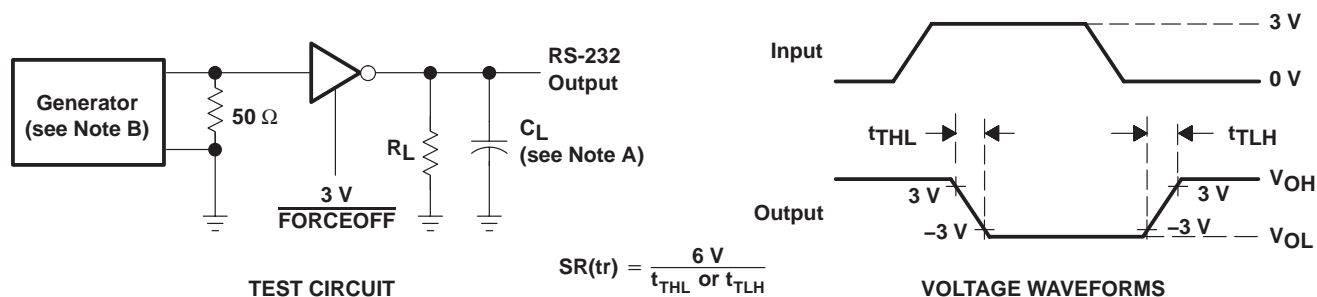

- NOTES: A.  $C_L$  includes probe and jig capacitance.  
 B. The pulse generator has the following characteristics: PRR = 250 kbit/s,  $Z_O = 50 \Omega$ , 50% duty cycle,  $t_r \leq 10 \text{ ns}$ ,  $t_f \leq 10 \text{ ns}$ .

**Figure 1. Driver Slew Rate**

**PACKAGING INFORMATION**

Orderable Device	Status <sup>(1)</sup>	Package Type	Package Drawing	Pins	Package Qty	Eco Plan <sup>(2)</sup>	Lead/Ball Finish	MSL Peak Temp <sup>(3)</sup>
MAX3243CDB	ACTIVE	SSOP	DB	28	50	Pb-Free (RoHS)	CU NIPDAU	Level-2-260C-1 YEAR/ Level-1-235C-UNLIM
MAX3243CDBE4	ACTIVE	SSOP	DB	28	50	Pb-Free (RoHS)	CU NIPDAU	Level-2-260C-1 YEAR/ Level-1-235C-UNLIM
MAX3243CDBR	ACTIVE	SSOP	DB	28	2000	Pb-Free (RoHS)	CU NIPDAU	Level-2-260C-1 YEAR/ Level-1-235C-UNLIM
MAX3243CDW	ACTIVE	SOIC	DW	28	20	Pb-Free (RoHS)	CU NIPDAU	Level-2-250C-1 YEAR/ Level-1-235C-UNLIM
MAX3243CDWR	ACTIVE	SOIC	DW	28	1000	Pb-Free (RoHS)	CU NIPDAU	Level-2-250C-1 YEAR/ Level-1-235C-UNLIM
MAX3243CPW	ACTIVE	TSSOP	PW	28	50	Pb-Free (RoHS)	CU NIPDAU	Level-1-250C-UNLIM
MAX3243CPWR	ACTIVE	TSSOP	PW	28	2000	Pb-Free (RoHS)	CU NIPDAU	Level-1-250C-UNLIM
MAX3243IDB	ACTIVE	SSOP	DB	28	50	Pb-Free (RoHS)	CU NIPDAU	Level-2-260C-1 YEAR/ Level-1-235C-UNLIM
MAX3243IDBE4	ACTIVE	SSOP	DB	28	50	Pb-Free (RoHS)	CU NIPDAU	Level-2-260C-1 YEAR/ Level-1-235C-UNLIM
MAX3243IDBR	ACTIVE	SSOP	DB	28	2000	Pb-Free (RoHS)	CU NIPDAU	Level-2-260C-1 YEAR/ Level-1-235C-UNLIM
MAX3243IDBRE4	ACTIVE	SSOP	DB	28	2000	Pb-Free (RoHS)	CU NIPDAU	Level-2-260C-1 YEAR/ Level-1-235C-UNLIM
MAX3243IDW	ACTIVE	SOIC	DW	28	20	Pb-Free (RoHS)	CU NIPDAU	Level-2-250C-1 YEAR/ Level-1-235C-UNLIM
MAX3243IDWR	ACTIVE	SOIC	DW	28	1000	Pb-Free (RoHS)	CU NIPDAU	Level-2-250C-1 YEAR/ Level-1-235C-UNLIM
MAX3243IPW	ACTIVE	TSSOP	PW	28	50	Pb-Free (RoHS)	CU NIPDAU	Level-1-250C-UNLIM
MAX3243IPWR	ACTIVE	TSSOP	PW	28	2000	Pb-Free (RoHS)	CU NIPDAU	Level-1-250C-UNLIM

<sup>(1)</sup> The marketing status values are defined as follows:

**ACTIVE:** Product device recommended for new designs.

**LIFEBUY:** TI has announced that the device will be discontinued, and a lifetime-buy period is in effect.

**NRND:** Not recommended for new designs. Device is in production to support existing customers, but TI does not recommend using this part in a new design.

**PREVIEW:** Device has been announced but is not in production. Samples may or may not be available.

**OBSOLETE:** TI has discontinued the production of the device.

<sup>(2)</sup> Eco Plan - The planned eco-friendly classification: Pb-Free (RoHS) or Green (RoHS & no Sb/Br) - please check <http://www.ti.com/productcontent> for the latest availability information and additional product content details.

**TBD:** The Pb-Free/Green conversion plan has not been defined.

**Pb-Free (RoHS):** TI's terms "Lead-Free" or "Pb-Free" mean semiconductor products that are compatible with the current RoHS requirements for all 6 substances, including the requirement that lead not exceed 0.1% by weight in homogeneous materials. Where designed to be soldered at high temperatures, TI Pb-Free products are suitable for use in specified lead-free processes.

**Green (RoHS & no Sb/Br):** TI defines "Green" to mean Pb-Free (RoHS compatible), and free of Bromine (Br) and Antimony (Sb) based flame retardants (Br or Sb do not exceed 0.1% by weight in homogeneous material)

<sup>(3)</sup> MSL, Peak Temp. -- The Moisture Sensitivity Level rating according to the JEDEC industry standard classifications, and peak solder temperature.

**Important Information and Disclaimer:** The information provided on this page represents TI's knowledge and belief as of the date that it is provided. TI bases its knowledge and belief on information provided by third parties, and makes no representation or warranty as to the