

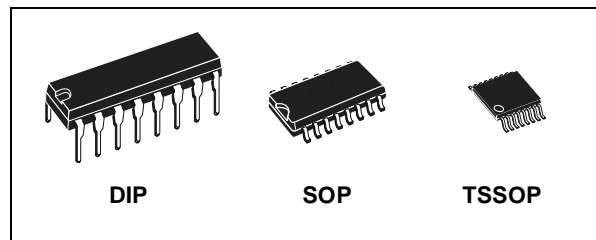

# M74HC590

## 8 BINARY COUNTER REGISTER WITH 3 STATE OUTPUT

- HIGH SPEED:  
 $f_{MAX} = 61 \text{ MHz (TYP.) at } V_{CC} = 6V$
- LOW POWER DISSIPATION:  
 $I_{CC} = 4\mu\text{A(MAX.) at } T_A=25^\circ\text{C}$
- HIGH NOISE IMMUNITY:  
 $V_{NIH} = V_{NIL} = 28 \% V_{CC} \text{ (MIN.)}$
- SYMMETRICAL OUTPUT IMPEDANCE:  
 $|I_{OH}| = I_{OL} = 6\text{mA (MIN) for QA} \sim \text{QH OUTPUT}$   
 $|I_{OH}| = I_{OL} = 4\text{mA (MIN) for RCO OUTPUT}$
- BALANCED PROPAGATION DELAYS:  
 $t_{PLH} \cong t_{PHL}$
- WIDE OPERATING VOLTAGE RANGE:  
 $V_{CC} \text{ (OPR)} = 2V \text{ to } 6V$
- PIN AND FUNCTION COMPATIBLE WITH 74 SERIES 590



### ORDER CODES

PACKAGE	TUBE	T & R
DIP	M74HC590B1R	
SOP	M74HC590M1R	M74HC590RM13TR
TSSOP		M74HC590TTR

### DESCRIPTION

The M74HC590 is an high speed CMOS 8-BIT BINARY COUNTER REGISTER (3 STATE) fabricated with silicon gate C<sup>2</sup>MOS technology. This device contains an 8-bit binary counter that feeds an 8-bit storage register. The storage register has parallel outputs. Separate clocks are provided for both the binary counter and storage register. The binary counter features a direct clear input CCLR and a count enable input CCKEN. For

cascading, a ripple carry output  $\overline{\text{RCO}}$  is provided. Expansion is easily accomplished by tying RCO of the first stage to CCKEN of the second stage, etc. Both the counter and register clocks are positive edge triggered. If the user wishes to connect both clocks together, the counter state will always be one count ahead of the register. Internal circuitry prevents clocking from the clock enable. All inputs are equipped with protection circuits against static discharge and transient excess voltage.

### PIN CONNECTION AND IEC LOGIC SYMBOLS

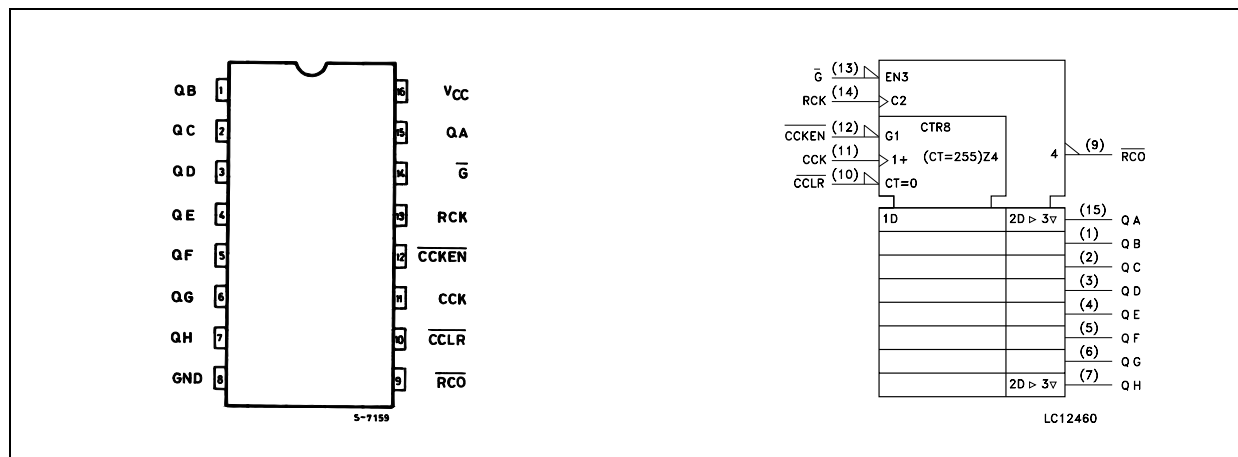

**ABSOLUTE MAXIMUM RATINGS**

Symbol	Parameter	Value	Unit
$V_{CC}$	Supply Voltage	-0.5 to +7	V
$V_I$	DC Input Voltage	-0.5 to $V_{CC} + 0.5$	V
$V_O$	DC Output Voltage	-0.5 to $V_{CC} + 0.5$	V
$I_{IK}$	DC Input Diode Current	$\pm 20$	mA
$I_{OK}$	DC Output Diode Current	$\pm 20$	mA
$I_O$	DC Output Source Sink Current per Output PIN (RCO) (QA - QH)	$\pm 25$ $\pm 35$	mA
$I_{CC}$ or $I_{GND}$	DC $V_{CC}$ or Ground Current	$\pm 70$	mA
$P_D$	Power Dissipation	500(*)	mW
$T_{stg}$	Storage Temperature	-65 to +150	°C
$T_L$	Lead Temperature (10 sec)	300	°C

Absolute Maximum Ratings are those values beyond which damage to the device may occur. Functional operation under these conditions is not implied

(\*) 500mW at 65 °C; derate to 300mW by 10mW/°C from 65°C to 85°C

**RECOMMENDED OPERATING CONDITIONS**

Symbol	Parameter	Value	Unit	
$V_{CC}$	Supply Voltage	2 to 6	V	
$V_I$	Input Voltage	0 to $V_{CC}$	V	
$V_O$	Output Voltage	0 to $V_{CC}$	V	
$T_{op}$	Operating Temperature	-55 to 125	°C	
$t_r, t_f$	Input Rise and Fall Time	$V_{CC} = 2.0V$	0 to 1000	ns
		$V_{CC} = 4.5V$	0 to 500	ns
		$V_{CC} = 6.0V$	0 to 400	ns

## DC SPECIFICATIONS

Symbol	Parameter	Test Condition		Value						Unit	
		V <sub>CC</sub> (V)		T <sub>A</sub> = 25°C			-40 to 85°C		-55 to 125°C		
				Min.	Typ.	Max.	Min.	Max.	Min.		Max.
V <sub>IH</sub>	High Level Input Voltage	2.0		1.5			1.5		1.5		V
		4.5		3.15			3.15		3.15		
		6.0		4.2			4.2		4.2		
V <sub>IL</sub>	Low Level Input Voltage	2.0				0.5		0.5		0.5	V
		4.5				1.35		1.35		1.35	
		6.0				1.8		1.8		1.8	
V <sub>OH</sub>	High Level Output Voltage (for RCO Output)	2.0	I <sub>O</sub> =-20 μA	1.9	2.0		1.9		1.9		V
		4.5	I <sub>O</sub> =-20 μA	4.4	4.5		4.4		4.4		
		6.0	I <sub>O</sub> =-20 μA	5.9	6.0		5.9		5.9		
		4.5	I <sub>O</sub> =-4.0 mA	4.18	4.31		4.13		4.10		
		6.0	I <sub>O</sub> =-5.2 mA	5.68	5.8		5.63		5.60		
V <sub>OH</sub>	High Level Output Voltage (for QA to QH Outputs)	2.0	I <sub>O</sub> =-20 μA	1.9	2.0		1.9		1.9		V
		4.5	I <sub>O</sub> =-20 μA	4.4	4.5		4.4		4.4		
		6.0	I <sub>O</sub> =-20 μA	5.9	6.0		5.9		5.9		
		4.5	I <sub>O</sub> =-6.0 mA	4.18	4.31		4.13		4.10		
		6.0	I <sub>O</sub> =-7.8 mA	5.68	5.8		5.63		5.60		
V <sub>OL</sub>	Low Level Output Voltage (for RCO Output)	2.0	I <sub>O</sub> =20 μA		0.0	0.1		0.1		0.1	V
		4.5	I <sub>O</sub> =20 μA		0.0	0.1		0.1		0.1	
		6.0	I <sub>O</sub> =20 μA		0.0	0.1		0.1		0.1	
		4.5	I <sub>O</sub> =4.0 mA		0.17	0.26		0.33		0.40	
		6.0	I <sub>O</sub> =5.2 mA		0.18	0.26		0.33		0.40	
V <sub>OL</sub>	Low Level Output Voltage (for QA to QH Outputs)	2.0	I <sub>O</sub> =20 μA		0.0	0.1		0.1		0.1	V
		4.5	I <sub>O</sub> =20 μA		0.0	0.1		0.1		0.1	
		6.0	I <sub>O</sub> =20 μA		0.0	0.1		0.1		0.1	
		4.5	I <sub>O</sub> =6.0 mA		0.17	0.26		0.33		0.40	
		6.0	I <sub>O</sub> =7.8 mA		0.18	0.26		0.33		0.40	
I <sub>I</sub>	Input Leakage Current	6.0	V <sub>I</sub> = V <sub>CC</sub> or GND			± 0.1		± 1		± 1	μA
I <sub>OZ</sub>	High Impedance Output Leakage Current	6.0	V <sub>I</sub> = V <sub>IH</sub> or V <sub>IL</sub> V <sub>O</sub> = V <sub>CC</sub> or GND			± 0.5		± 5		± 10	μA
I <sub>CC</sub>	Quiescent Supply Current	6.0	V <sub>I</sub> = V <sub>CC</sub> or GND			4		40		80	μA

AC ELECTRICAL CHARACTERISTICS ( $C_L = 50 \text{ pF}$ , Input  $t_r = t_f = 6 \text{ ns}$ )

Symbol	Parameter	Test Condition			Value						Unit	
		$V_{CC}$ (V)	$C_L$ (pF)		$T_A = 25^\circ\text{C}$			$-40 \text{ to } 85^\circ\text{C}$		$-55 \text{ to } 125^\circ\text{C}$		
					Min.	Typ.	Max.	Min.	Max.	Min.		Max.
$t_{TLH}$ $t_{THL}$	Output Transition Time	2.0	50			25	60		75		90	ns
		4.5			7	12		15		18		
		6.0			6	10		13		15		
$t_{TLH}$ $t_{THL}$	Output Transition Time (RCO)	2.0	50			30	75		95		115	ns
		4.5			8	15		19		23		
		6.0			7	13		16		20		
$t_{PLH}$ $t_{PHL}$	Propagation Delay Time (CCK - $\overline{\text{RCO}}$ )	2.0	50			56	165		205		250	ns
		4.5			19	33		41		50		
		6.0			16	28		35		43		
$t_{PLH}$	Propagation Delay Time (CCLR - $\overline{\text{RCO}}$ )	2.0	50			53	175		220		265	ns
		4.5			21	35		44		53		
		6.0			18	30		37		45		
$t_{PLH}$ $t_{PHL}$	Propagation Delay Time (RCK - Q)	2.0	50			48	145		180		220	ns
		4.5			17	29		36		44		
		6.0			14	25		31		37		
		2.0	150			60	185		230		280	ns
		4.5			21	37		46		56		
		6.0			18	31		39		48		
$t_{PZL}$ $t_{PZH}$	High Impedance Output Enable Time	2.0	50	$R_L = 1 \text{ K}\Omega$		39	105		130		160	ns
		4.5				13	21		26		32	
		6.0				11	18		22		27	
		2.0	150	$R_L = 1 \text{ K}\Omega$		51	135		170		205	ns
		4.5				17	27		34		41	
		6.0				14	23		29		35	
$t_{PLZ}$ $t_{PHZ}$	High Impedance Output Disable Time	2.0	50	$R_L = 1 \text{ K}\Omega$		28	105		130		160	ns
		4.5				14	21		26		32	
		6.0				12	18		22		27	
$f_{MAX}$	Maximum Clock Frequency	2.0	50		6.6	13		5.2		4.4	MHz	
		4.5			33	52		26		22		
		6.0			39	61		31		26		
$t_{W(L)}$ $t_{W(H)}$	Minimum Pulse Width (CCK, RCK)	2.0	50			36	100		125		145	ns
		4.5			9	20		25		29		
		6.0			8	17		21		25		
$t_{W(L)}$	Minimum Pulse Width (CCLR)	2.0	50			32	75		95		110	ns
		4.5			8	15		19		22		
		6.0			7	13		16		19		
$t_s$	Minimum Set-up Time (CCKEN - CCK)	2.0	50			44	100		125		150	ns
		4.5			11	20		25		30		
		6.0			9	17		21		26		
$t_{s(H)}$	Minimum Set-up Time (CCK - RCK)	2.0	50			76	175		220		255	ns
		4.5			19	35		44		51		
		6.0			16	30		37		43		
$t_h$	Minimum Hold Time	2.0	50				0		0		0	ns
		4.5				0		0		0		
		6.0				0		0		0		

# M74HC590

Symbol	Parameter	Test Condition			Value						Unit	
		V <sub>CC</sub> (V)	C <sub>L</sub> (pF)		T <sub>A</sub> = 25°C			-40 to 85°C		-55 to 125°C		
					Min.	Typ.	Max.	Min.	Max.	Min.		Max.
t <sub>REM</sub>	Minimum Removal Time (CCLR)	2.0	50			28	75		95		110	ns
		4.5			7	15		19		22		
		6.0			6	13		16		19		

## CAPACITIVE CHARACTERISTICS

Symbol	Parameter	Test Condition			Value						Unit	
		V <sub>CC</sub> (V)			T <sub>A</sub> = 25°C			-40 to 85°C		-55 to 125°C		
					Min.	Typ.	Max.	Min.	Max.	Min.		Max.
C <sub>IN</sub>	Input Capacitance					5	10		10		10	pF
C <sub>PD</sub>	Power Dissipation Capacitance (note 1)					40						pF

1) C<sub>PD</sub> is defined as the value of the IC's internal equivalent capacitance which is calculated from the operating current consumption without load. (Refer to Test Circuit). Average operating current can be obtained by the following equation.  $I_{CC(oper)} = C_{PD} \times V_{CC} \times f_{IN} + I_{CC}$

## TEST CIRCUIT

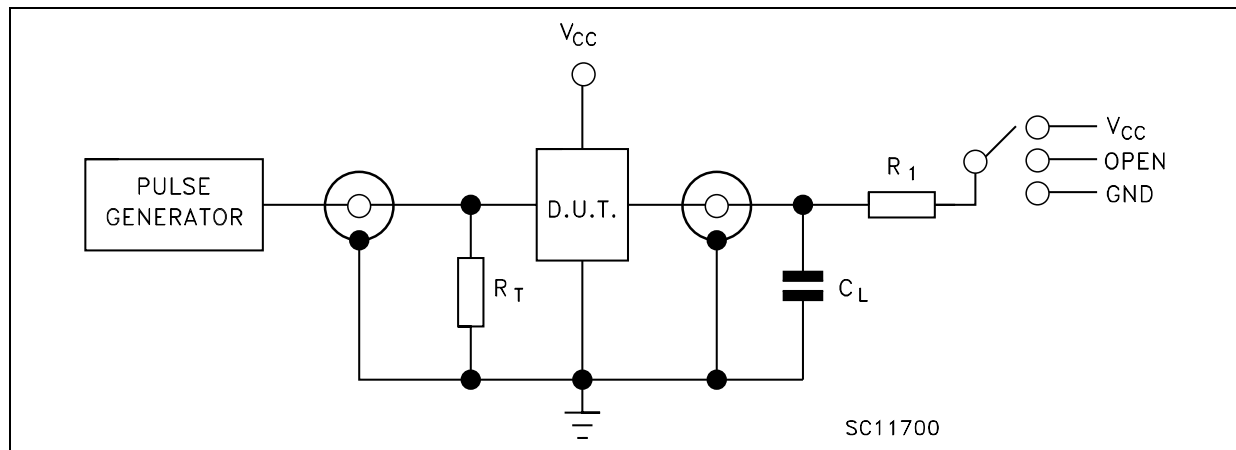

TEST	SWITCH
t <sub>PLH</sub> , t <sub>PHL</sub>	Open
t <sub>PZL</sub> , t <sub>PLZ</sub>	V <sub>CC</sub>
t <sub>PZH</sub> , t <sub>PHZ</sub>	GND

C<sub>L</sub> = 50pF/150pF or equivalent (includes jig and probe capacitance)

R<sub>1</sub> = 1KΩ or equivalent

R<sub>T</sub> = Z<sub>OUT</sub> of pulse generator (typically 50Ω)

**Plastic DIP-16 (0.25) MECHANICAL DATA**

DIM.	mm.			inch		
	MIN.	TYP	MAX.	MIN.	TYP.	MAX.
a1	0.51			0.020		
B	0.77		1.65	0.030		0.065
b		0.5			0.020	
b1		0.25			0.010	
D			20			0.787
E		8.5			0.335	
e		2.54			0.100	
e3		17.78			0.700	
F			7.1			0.280
I			5.1			0.201
L		3.3			0.130	
Z			1.27			0.050

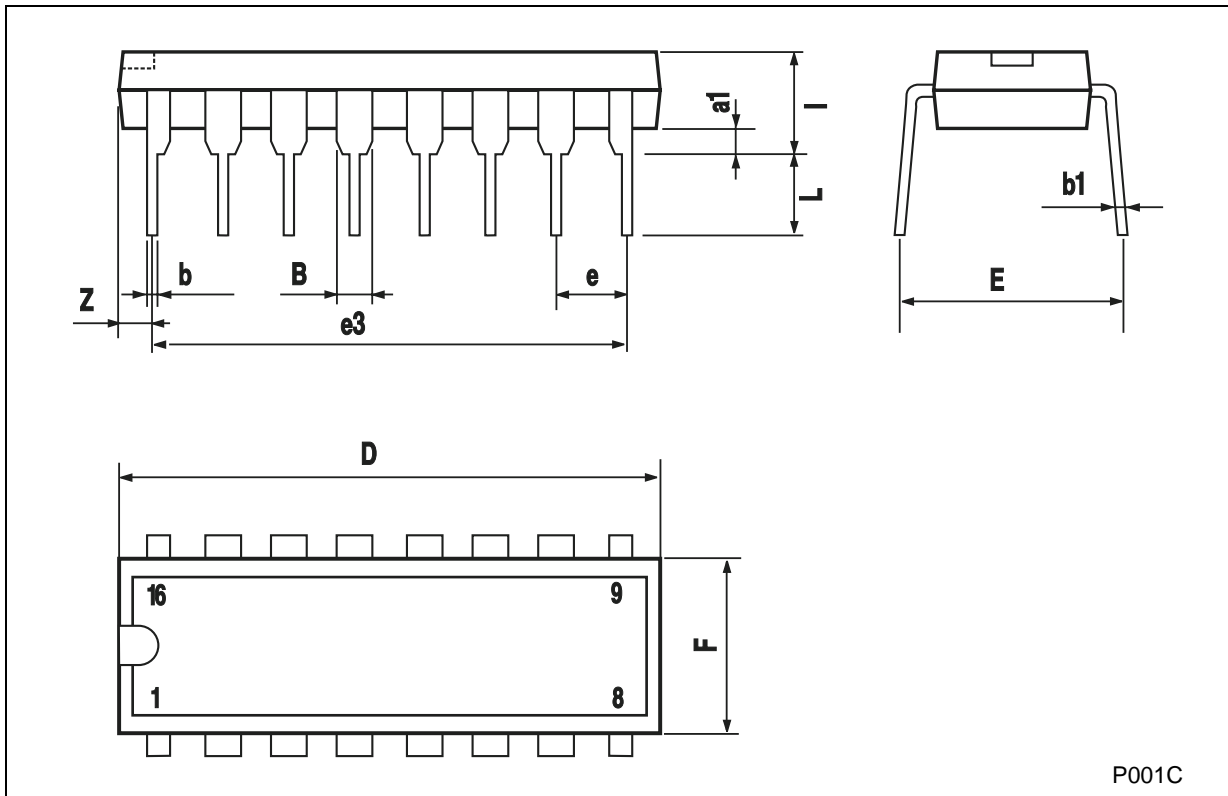

P001C