

5 V, 16 Kbit (2 Kb x 8) ZEROPOWER[®] SRAM

Features

- Integrated, ultra low power SRAM and power-fail control circuit
- Unlimited WRITE cycles
- READ cycle time equals WRITE cycle time
- Automatic power-fail chip deselect and WRITE protection
- WRITE protect voltages (V_{PFD} = Power-fail deselect voltage):
 - M48Z02: $V_{\text{CC}} = 4.75$ to 5.5 V;
 4.5 V $\leq V_{\text{PFD}} \leq 4.75$ V
 - M48Z12: $V_{\text{CC}} = 4.5$ to 5.5 V;
 4.2 V $\leq V_{\text{PFD}} \leq 4.5$ V
- Self-contained battery in the CAPHAT[™] DIP package
- Pin and function compatible with JEDEC standard 2 K x 8 SRAMs
- RoHS compliant
 - Lead-free second level interconnect

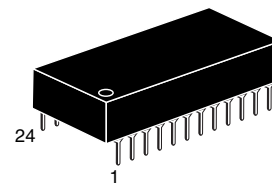

PCDIP24 (PC)
battery CAPHAT[™]

1 Description

The M48Z02/12 ZEROPOWER® RAM is a 2 K x 8 non-volatile static RAM which is pin and functional compatible with the DS1220.

A special 24-pin, 600 mil DIP CAPHAT™ package houses the M48Z02/12 silicon with a long life lithium button cell to form a highly integrated battery backed-up memory solution.

The M48Z02/12 button cell has sufficient capacity and storage life to maintain data functionality for an accumulated time period of at least 10 years in the absence of power over commercial operating temperature range.

The M48Z02/12 is a non-volatile pin and function equivalent to any JEDEC standard 2 K x 8 SRAM. It also easily fits into many ROM, EPROM, and EEPROM sockets, providing the non-volatility of PROMs without any requirement for special WRITE timing or limitations on the number of WRITES that can be performed.

Figure 1. Logic diagram

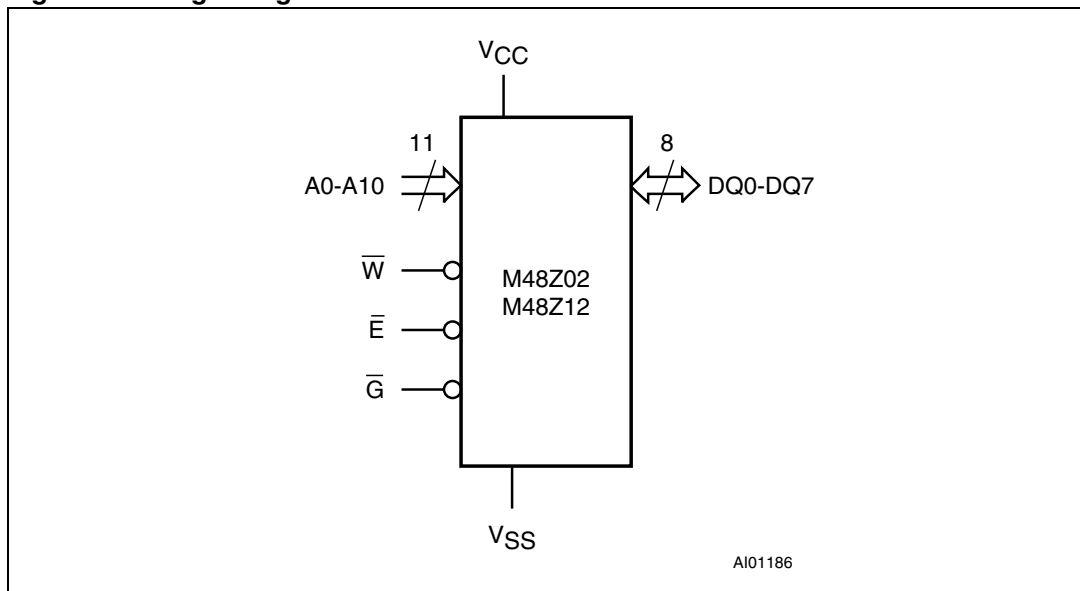
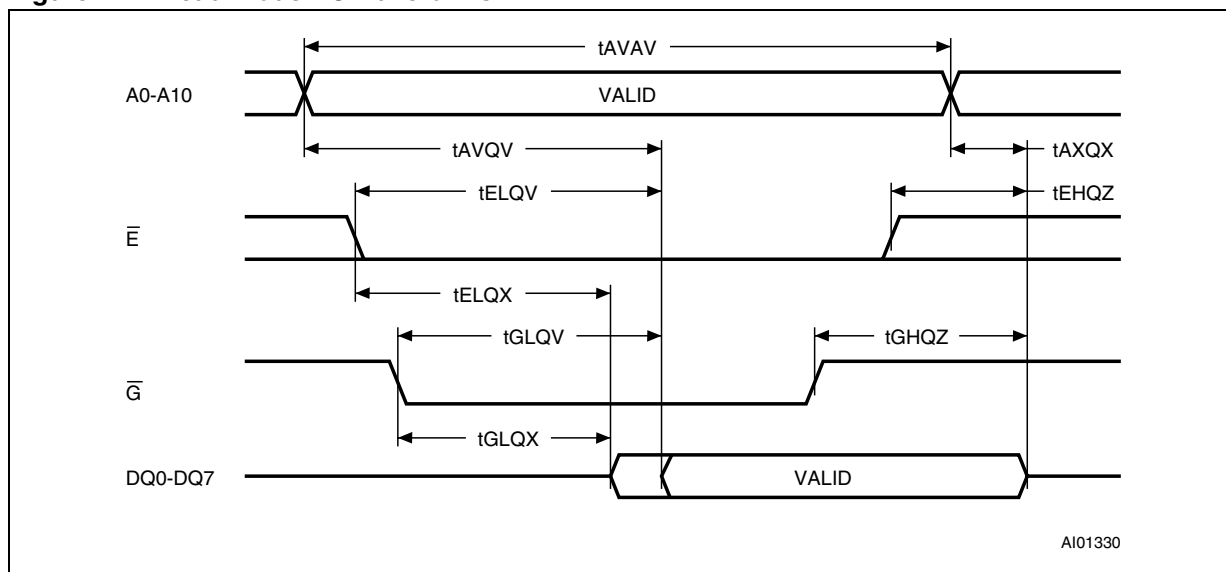

Table 1. Signal names

A0-A10	Address inputs
DQ0-DQ7	Data inputs / outputs
\bar{E}	Chip enable
\bar{G}	Output enable
\bar{W}	WRITE enable
V _{CC}	Supply voltage
V _{SS}	Ground

Figure 4. Read mode AC waveforms



Note: WRITE enable (\bar{W}) = high.

Table 3. Read mode AC characteristics

Symbol	Parameter ⁽¹⁾	M48Z02/M48Z12						Unit
		-70		-150		-200		
		Min	Max	Min	Max	Min	Max	
t_{AVAV}	READ cycle time	70		150		200		ns
t_{AVQV}	Address valid to output valid		70		150		200	ns
t_{ELQV}	Chip enable low to output valid		70		150		200	ns
t_{GLQV}	Output enable low to output valid		35		75		80	ns
t_{ELQX}	Chip enable low to output transition	5		10		10		ns
t_{GLQX}	Output enable low to output transition	5		5		5		ns
t_{EHQZ}	Chip enable high to output Hi-Z		25		35		40	ns
t_{GHQZ}	Output enable high to output Hi-Z		25		35		40	ns
t_{AXQX}	Address transition to output transition	10		5		5		ns

1. Valid for ambient operating temperature: $T_A = 0$ to 70°C or -40 to 85°C ; $V_{CC} = 4.75$ to 5.5 V or 4.5 to 5.5 V (except where noted).

2.2 Write mode

The M48Z02/12 is in the WRITE mode whenever \bar{W} and \bar{E} are active. The start of a WRITE is referenced from the latter occurring falling edge of \bar{W} or \bar{E} . A WRITE is terminated by the earlier rising edge of \bar{W} or \bar{E} . The addresses must be held valid throughout the cycle. \bar{E} or \bar{W} must return high for a minimum of t_{EHAX} from chip enable or t_{WHAX} from WRITE enable prior to the initiation of another READ or WRITE cycle. Data-in must be valid t_{DVWH} prior to the end of WRITE and remain valid for t_{WHDX} afterward. \bar{G} should be kept high during WRITE cycles to avoid bus contention; although, if the output bus has been activated by a low on \bar{E} and \bar{G} , a low on \bar{W} will disable the outputs t_{WLQZ} after \bar{W} falls.

Table 4. Write mode AC characteristics

Symbol	Parameter ⁽¹⁾	M48Z02/M48Z12						Unit
		-70		-150		-200		
		Min	Max	Min	Max	Min	Max	
t _{AVAV}	WRITE cycle time	70		150		200		ns
t _{AVWL}	Address valid to WRITE enable low	0		0		0		ns
t _{AVEL}	Address valid to chip enable 1 low	0		0		0		ns
t _{WLWH}	WRITE enable pulse width	50		90		120		ns
t _{ELEH}	Chip enable low to chip enable 1 high	55		90		120		ns
t _{WHAX}	WRITE enable high to address transition	0		10		10		ns
t _{EHAX}	Chip enable high to address transition	0		10		10		ns
t _{DVWH}	Input valid to WRITE enable high	30		40		60		ns
t _{DVEH}	Input valid to Chip enable high	30		40		60		ns
t _{WHDX}	WRITE enable high to input transition	5		5		5		ns
t _{EHDX}	Chip enable high to input transition	5		5		5		ns
t _{WLQZ}	WRITE enable low to output Hi-Z		25		50		60	ns
t _{AVWH}	Address valid to WRITE enable high	60		120		140		ns
t _{AVEH}	Address valid to chip enable high	60		120		140		ns
t _{WHQX}	WRITE enable high to output transition	5		10		10		ns

1. Valid for ambient operating temperature: T_A = 0 to 70°C or -40 to 85°C; V_{CC} = 4.75 to 5.5 V or 4.5 to 5.5 V (except where noted).

2.3 Data retention mode

With valid V_{CC} applied, the M48Z02/12 operates as a conventional BYTEWIDE™ static RAM. Should the supply voltage decay, the RAM will automatically power-fail deselect, write protecting itself when V_{CC} falls within the V_{PFD} (max), V_{PFD} (min) window. All outputs become high impedance, and all inputs are treated as “don't care.”

Note: A power failure during a WRITE cycle may corrupt data at the currently addressed location, but does not jeopardize the rest of the RAM's content. At voltages below V_{PFD} (min), the user can be assured the memory will be in a write protected state, provided the V_{CC} fall time is not less than t_F. The M48Z02/12 may respond to transient noise spikes on V_{CC} that reach into the deselect window during the time the device is sampling V_{CC}. Therefore, decoupling of the power supply lines is recommended.

The power switching circuit connects external V_{CC} to the RAM and disconnects the battery when V_{CC} rises above V_{SO}. As V_{CC} rises, the battery voltage is checked. If the voltage is too low, an internal Battery Not OK (BOK) flag will be set. The BOK flag can be checked after power up. If the BOK flag is set, the first WRITE attempted will be blocked. The flag is automatically cleared after the first WRITE, and normal RAM operation resumes. [Figure 7 on page 11](#) illustrates how a BOK check routine could be structured.

For more information on a battery storage life refer to the application note AN1012.

3 Maximum ratings

Stressing the device above the rating listed in the absolute maximum ratings table may cause permanent damage to the device. These are stress ratings only and operation of the device at these or any other conditions above those indicated in the operating sections of this specification is not implied. Exposure to absolute maximum rating conditions for extended periods may affect device reliability. Refer also to the STMicroelectronics SURE Program and other relevant quality documents.

Table 5. Absolute maximum ratings

Symbol	Parameter		Value	Unit
T_A	Ambient operating temperature	Grade 1	0 to 70	°C
T_{STG}	Storage temperature (V_{CC} off, oscillator off)		-40 to 85	°C
$T_{SLD}^{(1)}$	Lead solder temperature for 10 seconds		260	°C
V_{IO}	Input or output voltages		-0.3 to 7	V
V_{CC}	Supply voltage		-0.3 to 7	V
I_O	Output current		20	mA
P_D	Power dissipation		1	W

1. Soldering temperature not to exceed 260°C for 10 seconds (total thermal budget not to exceed 150°C for longer than 30 seconds).

Caution: *Negative undershoots below -0.3 V are not allowed on any pin while in the battery backup mode.*

4 DC and AC parameters

This section summarizes the operating and measurement conditions, as well as the DC and AC characteristics of the device. The parameters in the following DC and AC characteristic tables are derived from tests performed under the measurement conditions listed in [Table 6: Operating and AC measurement conditions](#). Designers should check that the operating conditions in their projects match the measurement conditions when using the quoted parameters.

Table 6. Operating and AC measurement conditions

Parameter		M48Z02	M48Z12	Unit
Supply voltage (V_{CC})		4.75 to 5.5	4.5 to 5.5	V
Ambient operating temperature (T_A)	Grade 1	0 to 70	0 to 70	°C
Load capacitance (C_L)		100	100	pF
Input rise and fall times		≤ 5	≤ 5	ns
Input pulse voltages		0 to 3	0 to 3	V
Input and output timing ref. voltages		1.5	1.5	V

Note: Output Hi-Z is defined as the point where data is no longer driven.

Figure 9. AC testing load circuit

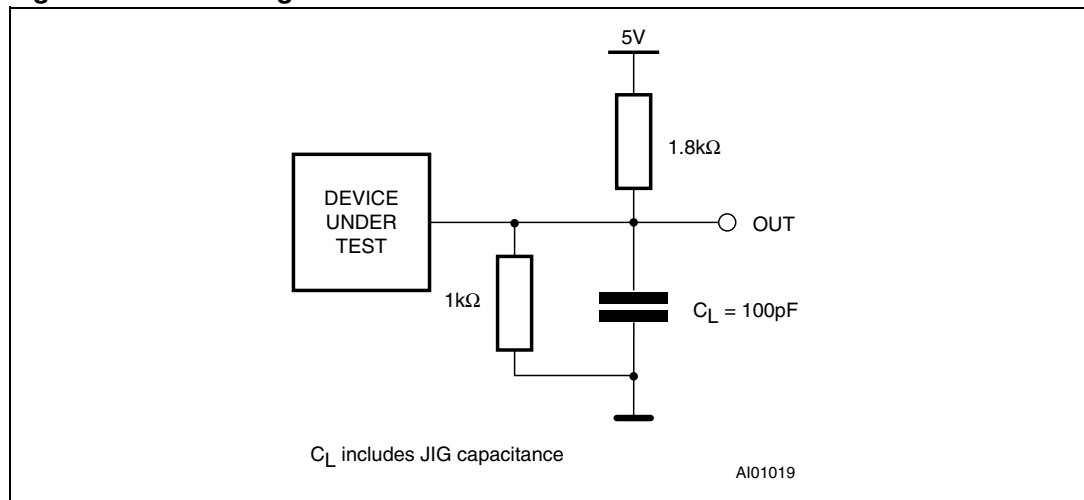

Table 7. Capacitance

Symbol	Parameter ⁽¹⁾⁽²⁾	Min	Max	Unit
C_{IN}	Input capacitance		10	pF
$C_{IO}^{(3)}$	Input / output capacitance		10	pF

1. Effective capacitance measured with power supply at 5 V. Sampled only, not 100% tested.
2. At 25°C, f = 1 MHz.
3. Outputs deselected.

Table 8. DC characteristics

Symbol	Parameter	Test condition ⁽¹⁾	Min	Max	Unit
I_{LI}	Input leakage current	$0V \leq V_{IN} \leq V_{CC}$		± 1	μA
$I_{LO}^{(2)}$	Output leakage current	$0V \leq V_{OUT} \leq V_{CC}$		± 1	μA
I_{CC}	Supply current	Outputs open		80	mA
I_{CC1}	Supply current (standby) TTL	$\bar{E} = V_{IH}$		3	mA
I_{CC2}	Supply current (standby) CMOS	$\bar{E} = V_{CC} - 0.2V$		3	mA
V_{IL}	Input low voltage		-0.3	0.8	V
V_{IH}	Input high voltage		2.2	$V_{CC} + 0.3$	V
V_{OL}	Output low voltage	$I_{OL} = 2.1mA$		0.4	V
V_{OH}	Output high voltage	$I_{OH} = -1mA$	2.4		V

- Valid for ambient operating temperature: $T_A = 0$ to $70^\circ C$; $V_{CC} = 4.75$ to 5.5 V or 4.5 to 5.5 V (except where noted).
- Outputs deselected.

Figure 10. Power down/up mode AC waveforms

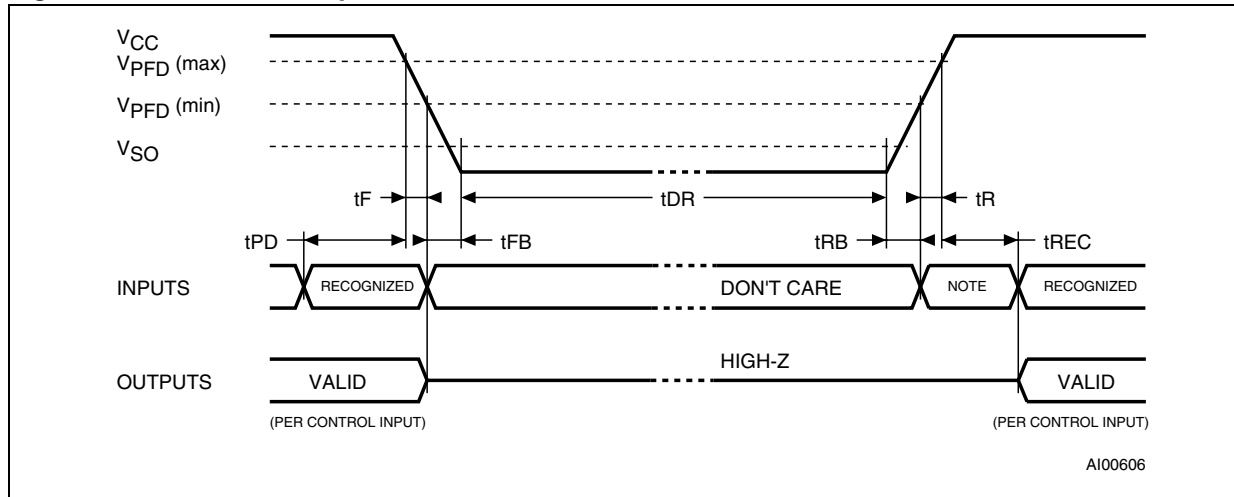

Note: Inputs may or may not be recognized at this time. Caution should be taken to keep \bar{E} high as V_{CC} rises past V_{PFD} (min). Some systems may perform inadvertent WRITE cycles after V_{CC} rises above V_{PFD} (min) but before normal system operations begin. Even though a power on reset is being applied to the processor, a reset condition may not occur until after the system is running.

Table 9. Power down/up AC characteristics

Symbol	Parameter ⁽¹⁾	Min	Max	Unit
t _{PD}	\overline{E} or \overline{W} at V _{IH} before power down	0		μs
t _F ⁽²⁾	V _{PFD} (max) to V _{PFD} (min) V _{CC} fall time	300		μs
t _{FB} ⁽³⁾	V _{PFD} (min) to V _{SS} V _{CC} fall time	10		μs
t _R	V _{PFD} (min) to V _{PFD} (max) V _{CC} rise time	0		μs
t _{RB}	V _{SS} to V _{PFD} (min) V _{CC} rise time	1		μs
t _{REC}	\overline{E} or \overline{W} at V _{IH} after power up	2		ms

- Valid for ambient operating temperature: T_A = 0 to 70°C; V_{CC} = 4.75 to 5.5 V or 4.5 to 5.5 V (except where noted).
- V_{PFD} (max) to V_{PFD} (min) fall time of less than t_F may result in deselection/write protection not occurring until 200 μs after V_{CC} passes V_{PFD} (min).
- V_{PFD} (min) to V_{SS} fall time of less than t_{FB} may cause corruption of RAM data.

Table 10. Power down/up trip points DC characteristics

Symbol	Parameter ⁽¹⁾⁽²⁾	Min	Typ	Max	Unit	
V _{PFD}	Power-fail deselect voltage	M48Z02	4.5	4.6	4.75	V
		M48Z12	4.2	4.3	4.5	V
V _{SO}	Battery backup switchover voltage		3.0		V	
t _{DR} ⁽³⁾	Expected data retention time	10			YEARS	

- All voltages referenced to V_{SS}.
- Valid for ambient operating temperature: T_A = 0 to 70°C; V_{CC} = 4.75 to 5.5 V or 4.5 to 5.5 V (except where noted).
- At 25°C, V_{CC} = 0 V.

5 Package mechanical data

In order to meet environmental requirements, ST offers these devices in ECOPACK[®] packages. These packages have a lead-free second level interconnect. The category of second Level Interconnect is marked on the package and on the inner box label, in compliance with JEDEC Standard JESD97. The maximum ratings related to soldering conditions are also marked on the inner box label. ECOPACK is an ST trademark. ECOPACK specifications are available at: www.st.com.

Figure 11. PCDIP24 – 24-pin plastic DIP, battery CAPHAT™, package outline

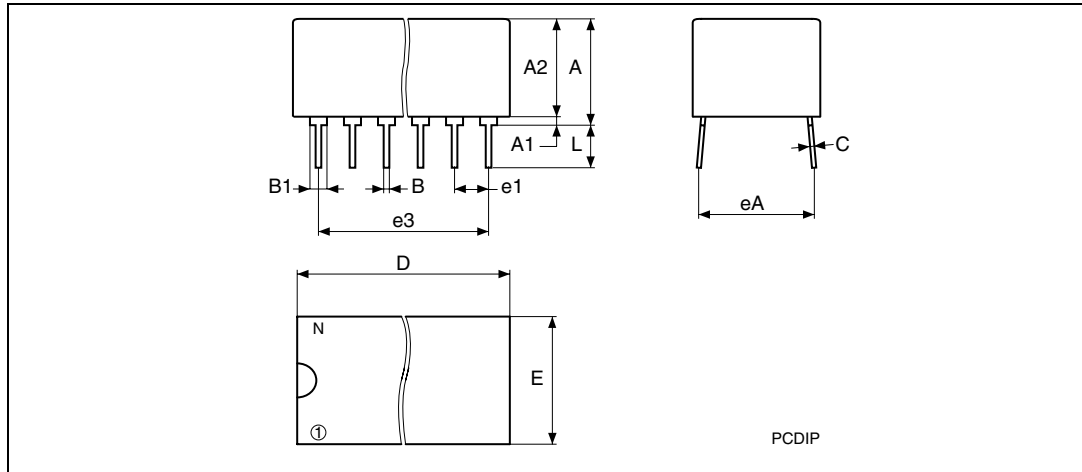

Note: Drawing is not to scale.

Table 11. PCDIP24 – 24-pin plastic DIP, battery CAPHAT™, package mechanical data

Symb	mm			inches		
	Typ	Min	Max	Typ	Min	Max
A		8.89	9.65		0.350	0.380
A1		0.38	0.76		0.015	0.030
A2		8.38	8.89		0.330	0.350
B		0.38	0.53		0.015	0.021
B1		1.14	1.78		0.045	0.070
C		0.20	0.31		0.008	0.012
D		34.29	34.80		1.350	1.370
E		17.83	18.34		0.702	0.722
e1		2.29	2.79		0.090	0.110
e3		25.15	30.73		0.990	1.210
eA		15.24	16.00		0.600	0.630
L		3.05	3.81		0.120	0.150
N		24			24	

6 Part numbering

Table 12. Ordering information scheme

Example:	M48Z	02	-70	PC	1
Device type					
M48Z					
Supply voltage and write protect voltage					
02 = $V_{CC} = 4.75$ to 5.5 V; $V_{PFD} = 4.5$ to 4.75 V					
12 = $V_{CC} = 4.5$ to 5.5 V; $V_{PFD} = 4.2$ to 4.5 V					
Speed					
-70 = 70 ns (M48Z02/12)					
-150 = 150 ns (M48Z02/12)					
-200 = 200 ns (M48Z02/12)					
Package					
PC = PCDIP24					
Temperature range					
1 = 0 to 70°C					
Shipping method					
blank = ECOPACK® package, tubes					

For a list of available options (e.g., speed, package) or for further information on any aspect of this device, please contact the ST sales office nearest you.