

Distributed by:



www.Jameco.com ♦ 1-800-831-4242

The content and copyrights of the attached material are the property of its owner.

Jameco Part Number 698349



M27C64A

64 Kbit (8Kb x8) UV EPROM and OTP EPROM

Feature summary

- $5V \pm 10\%$ supply voltage in Read operation
- Access time: 100ns
- Low power "CMOS" consumption:
 - Active Current 30mA
 - Standby Current 100 μ A
- Programming voltage: $12.5V \pm 0.25V$
- High speed programming (less than 1 minute)
- Electronic signature
 - Manufacturer Code: 9Bh
 - Device Code: 08h
- ECOPACK[®] packages available

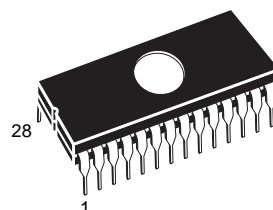

FDIP28W (F)



PLCC32 (K)

Contents

1	Summary description	5
2	Device operation	8
2.1	Read mode	8
2.2	Standby mode	8
2.3	Two Line output control	8
2.4	System considerations	8
2.5	Programming	9
2.6	High-speed programming	9
2.7	Program Inhibit	10
2.8	Program Verify	10
2.9	Electronic Signature	10
2.10	Erase operation (applies to UV EPROMs)	10
3	Maximum rating	12
4	DC and AC parameters	13
5	Package mechanical data	18
6	Part numbering	20
7	Revision history	21

List of tables

Table 1.	Signal Names	6
Table 2.	Operating Modes	11
Table 3.	Electronic Signature	11
Table 4.	Absolute Maximum Ratings	12
Table 5.	AC Measurement Conditions	13
Table 6.	Capacitance	13
Table 7.	Read Mode DC Characteristics	14
Table 8.	Programming Mode DC Characteristics	14
Table 9.	Read Mode AC Characteristics 1	15
Table 10.	Read Mode AC Characteristics 2	15
Table 11.	Programming Mode AC Characteristics	17
Table 12.	FDIP28W - 28 pin Ceramic Frit-seal DIP, with window, Package Mechanical Data.	18
Table 13.	PLCC32 - 32 lead Plastic Leaded Chip Carrier, mechanical data	19
Table 14.	Ordering Information Scheme.	20
Table 15.	Document revision history	21

List of figures

Figure 1.	Logic Diagram	6
Figure 2.	DIP Connections	7
Figure 3.	Pin Connections	7
Figure 4.	Programming Flowchart	9
Figure 5.	AC Testing Input Output Waveform	13
Figure 6.	AC Testing Load Circuit	13
Figure 7.	Read Mode AC Waveforms	16
Figure 8.	Programming and Verify Modes AC Waveforms	17
Figure 9.	FDIP28W - 28 pin Ceramic Frit-seal DIP, with window, Package Outline	18
Figure 10.	PLCC32 - 32 lead Plastic Leaded Chip Carrier, Package Outline	19

1 Summary description

The M27C64A is a 64Kbit EPROM offered in the two ranges UV (ultra violet erase) and OTP (one time programmable). It is ideally suited for microprocessor systems requiring large programs and is organized as 8,192 by 8 bits.

The FDIP28W (window ceramic frit-seal package) has transparent lid which allows the user to expose the chip to ultraviolet light to erase the bit pattern. A new pattern can then be written to the device by following the programming procedure.

For applications where the content is programmed only on time and erasure is not required, the M27C64A is offered in PLCC32 package.

In order to meet environmental requirements, ST offers the M27C64A in ECOPACK® packages.

ECOPACK packages are Lead-free. The category of second Level Interconnect is marked on the package and on the inner box label, in compliance with JEDEC Standard JESD97. The maximum ratings related to soldering conditions are also marked on the inner box label.

ECOPACK is an ST trademark. ECOPACK specifications are available at: www.st.com.

Figure 1. Logic Diagram

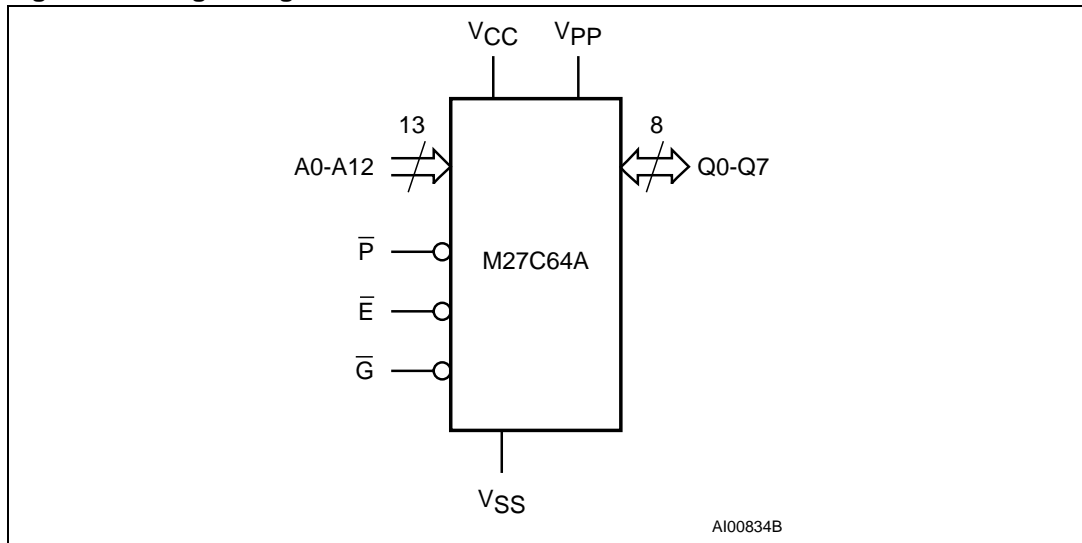

Table 1. Signal Names

A0-A12	Address Inputs
Q0-Q7	Data Outputs
\bar{E}	Chip Enable
\bar{G}	Output Enable
\bar{P}	Program
V_{PP}	Program Supply
V_{CC}	Supply Voltage
V_{SS}	Ground
NC	Not Connected Internally
DU	Don't Use

Figure 2. DIP Connections

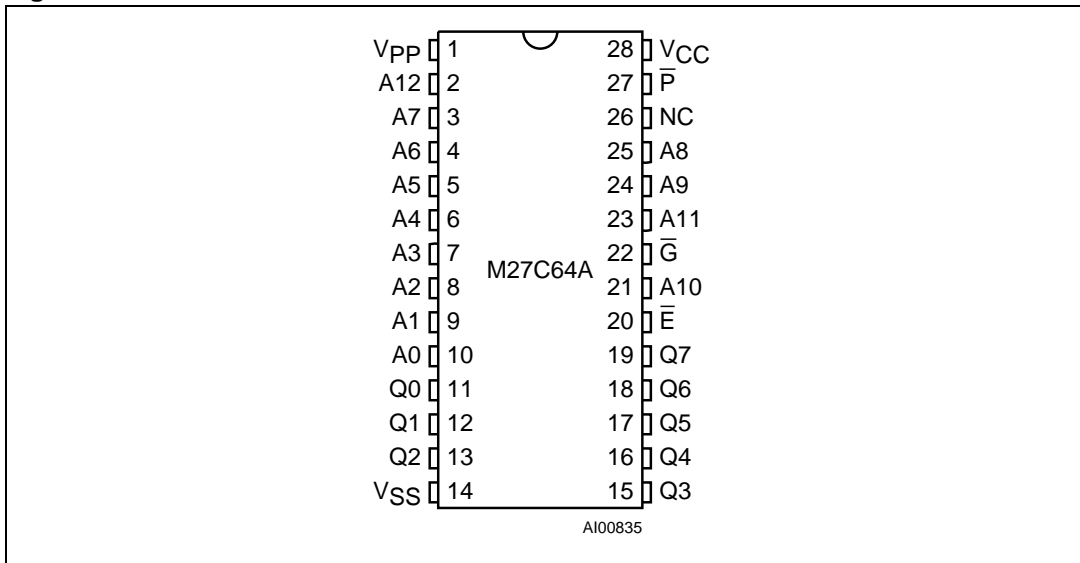
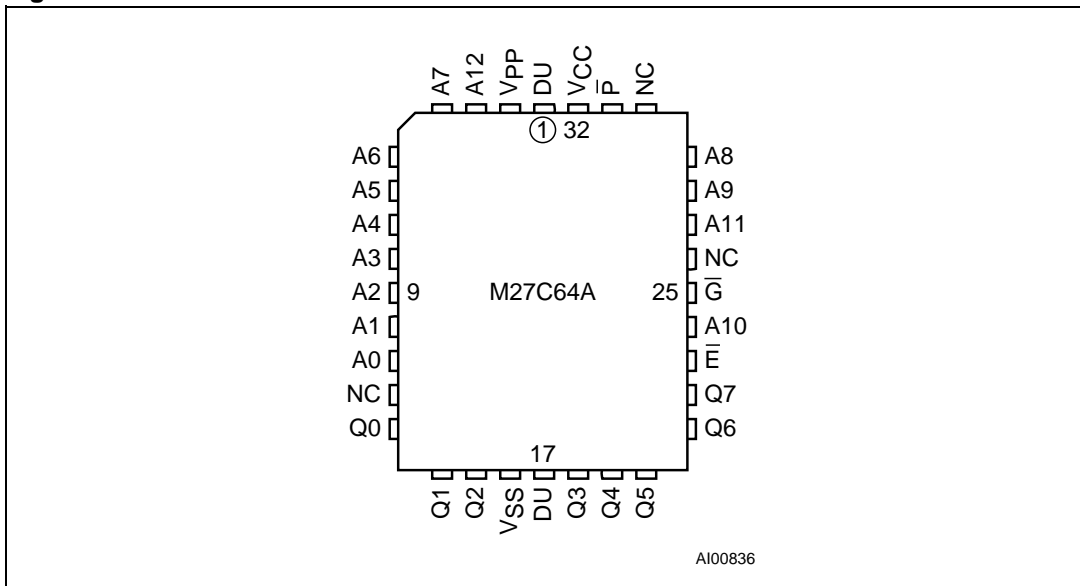

Figure 3. Pin Connections



2 Device operation

The modes of operation of the M27C64A are listed in the Operating Modes table. A single power supply is required in the read mode. All inputs are TTL levels except for V_{PP} and 12V on A9 for Electronic Signature.

2.1 Read mode

The M27C64A has two control functions, both of which must be logically active in order to obtain data at the outputs. Chip Enable (\bar{E}) is the power control and should be used for device selection. Output Enable (\bar{G}) is the output control and should be used to gate data to the output pins, independent of device selection. Assuming that the addresses are stable, the address access time (t_{AVQV}) is equal to the delay from \bar{E} to output (t_{ELQV}). Data is available at the output after a delay of t_{GLQV} from the falling edge of \bar{G} , assuming that \bar{E} has been low and the addresses have been stable for at least $t_{AVQV} - t_{GLQV}$.

2.2 Standby mode

The M27C64A has a standby mode which reduces the active current from 30mA to 100 μ A. The M27C64A is placed in the standby mode by applying a CMOS high signal to the \bar{E} input. When in the standby mode, the outputs are in a high impedance state, independent of the \bar{G} input.

2.3 Two Line output control

Because EPROMs are usually used in larger memory arrays, this product features a 2 line control function which accommodates the use of multiple memory connection. The two line control function allows:

- The lowest possible memory power dissipation
- Complete assurance that output bus contention will not occur

For the most efficient use of these two control lines, \bar{E} should be decoded and used as the primary device selecting function, while \bar{G} should be made a common connection to all devices in the array and connected to the \overline{READ} line from the system control bus. This ensures that all deselected memory devices are in their low power standby mode and that the output pins are only active when data is required from a particular memory device.

2.4 System considerations

The power switching characteristics of Advanced CMOS EPROMs require careful decoupling of the devices. The supply current, I_{CC} , has three segments that are of interest to the system designer: the standby current level, the active current level, and transient current peaks that are produced by the falling and rising edges of \bar{E} . The magnitude of the transient current peaks is dependent on the capacitive and inductive loading of the device at the output. The associated transient voltage peaks can be suppressed by complying with the two line output control and by properly selected decoupling capacitors. It is recommended that a 0.1 μ F ceramic capacitor be used on every device between V_{CC} and V_{SS} . This should

be a high frequency capacitor of low inherent inductance and should be placed as close to the device as possible. In addition, a 4.7 μ F bulk electrolytic capacitor should be used between V_{CC} and V_{SS} for every eight devices. The bulk capacitor should be located near the power supply connection point. The purpose of the bulk capacitor is to overcome the voltage drop caused by the inductive effects of PCB traces.

2.5 Programming

When delivered (and after each erasure for UV EPROM), all bits of the M27C64A are in the "1" state. Data is introduced by selectively programming "0"s into the desired bit locations. Although only "0"s will be programmed, both "1"s and "0"s can be present in the data word. The only way to change a "0" to a "1" is by die exposition to ultraviolet light (UV EPROM). The M27C64A is in the programming mode when V_{PP} input is at 12.5V, \bar{E} is at V_{IL} and \bar{P} is pulsed to V_{IL} . The data to be programmed is applied to 8 bits in parallel to the data output pins. The levels required for the address and data inputs are TTL. V_{CC} is specified to be 6V \pm 0.25V.

2.6 High-speed programming

The high speed programming algorithm, described in [Figure 4](#), rapidly programs the M27C64A using an efficient and reliable method, particularly suited to the production programming environment. An individual device will take around 1 minute to program.

Figure 4. Programming Flowchart

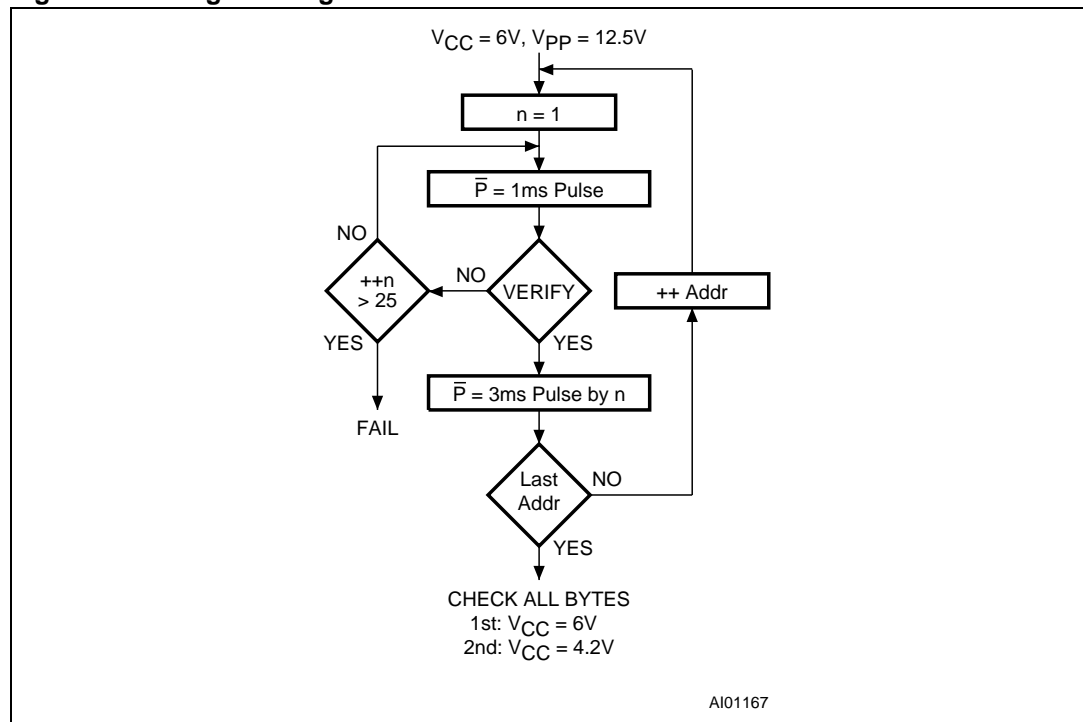

2.7 Program Inhibit

Programming of multiple M27C64A in parallel with different data is also easily accomplished. Except for \bar{E} , all like inputs including \bar{G} of the parallel M27C64A may be common. A TTL low level pulse applied to a M27C64A \bar{P} input, with \bar{E} low and V_{PP} at 12.5V, will program that M27C64A. A high level \bar{E} input inhibits the other M27C64A from being programmed.

2.8 Program Verify

A verify (read) should be performed on the programmed bits to determine that they were correctly programmed. The verify is accomplished with \bar{E} and \bar{G} at V_{IL} , \bar{P} at V_{IH} , V_{PP} at 12.5V and V_{CC} at 6V.

2.9 Electronic Signature

The Electronic Signature (ES) mode allows the reading out of a binary code from an EPROM that will identify its manufacturer and type. This mode is intended for use by programming equipment to automatically match the device to be programmed with its corresponding programming algorithm. The ES mode is functional in the $25^{\circ}\text{C} \pm 5^{\circ}\text{C}$ ambient temperature range that is required when programming the M27C64A. To activate the ES mode, the programming equipment must force 11.5V to 12.5V on address line A9 of the M27C64A, with $V_{PP} = V_{CC} = 5\text{V}$. Two identifier bytes may then be sequenced from the device outputs by toggling address line A0 from V_{IL} to V_{IH} . All other address lines must be held at V_{IL} during Electronic Signature mode.

Byte 0 ($A0 = V_{IL}$) represents the manufacturer code and byte 1 ($A0 = V_{IH}$) the device identifier code. For the STMicroelectronics M27C64A, these two identifier bytes are given in [Table 3: Electronic Signature](#) and can be read-out on outputs Q7 to Q0.

2.10 Erasure operation (applies to UV EPROMs)

The erasure characteristics of the M27C64A is such that erasure begins when the cells are exposed to light with wavelengths shorter than approximately 4000 Å. It should be noted that sunlight and some type of fluorescent lamps have wavelengths in the 3000-4000 Å range. Research shows that constant exposure to room level fluorescent lighting could erase a typical M27C64A in about 3 years, while it would take approximately 1 week to cause erasure when exposed to direct sunlight. If the M27C64A is to be exposed to these types of lighting conditions for extended periods of time, it is suggested that opaque labels be put over the M27C64A window to prevent unintentional erasure. The recommended erasure procedure for the M27C64A is exposure to short wave ultraviolet light which has a wavelength of 2537 Å. The integrated dose (i.e. UV intensity x exposure time) for erasure should be a minimum of 15 W-sec/cm². The erasure time with this dosage is approximately 15 to 20 minutes using an ultraviolet lamp with 12000 μW/cm² power rating. The M27C64A should be placed within 2.5 cm (1 inch) of the lamp tubes during the erasure. Some lamps have a filter on their tubes which should be removed before erasure.

Table 2. Operating Modes⁽¹⁾

Mode	\bar{E}	\bar{G}	\bar{P}	A9	V _{PP}	Q70-Q0
Read	V _{IL}	V _{IL}	V _{IH}	X	V _{CC}	Data Out
Output Disable	V _{IL}	V _{IH}	V _{IH}	X	V _{CC}	Hi-Z
Program	V _{IL}	X	V _{IL} Pulse	X	V _{PP}	Data Input
Verify	V _{IL}	V _{IL}	V _{IH}	X	V _{PP}	Data Output
Program Inhibit	V _{IH}	X	X	X	V _{PP}	Hi-Z
Standby	V _{IH}	X	X	X	V _{CC}	Hi-Z
Electronic Signature	V _{IL}	V _{IL}	V _{IH}	V _{ID}	V _{CC}	Codes

1. X = V_{IH} or V_{IL}, V_{ID} = 12V ± 0.5V.

Table 3. Electronic Signature

Identifier	A0	Q7	Q6	Q5	Q4	Q3	Q2	Q1	Q0	Hex Data
Manufacturer's Code	V _{IL}	1	0	0	1	1	0	1	1	9Bh
Device Code	V _{IH}	0	0	0	0	1	0	0	0	08h

3 Maximum rating

Stressing the device above the rating listed in the Absolute Maximum Ratings table may cause permanent damage to the device. These are stress ratings only and operation of the device at these or any other conditions above those indicated in the Operating sections of this specification is not implied. Exposure to Absolute Maximum Rating conditions for extended periods may affect device reliability. Refer also to the STMicroelectronics SURE Program and other relevant quality documents.

Table 4. Absolute Maximum Ratings⁽¹⁾

Symbol	Parameter	Value	Unit
T_A	Ambient Operating Temperature ⁽³⁾	-40 to 125	°C
T_{BIAS}	Temperature Under Bias	-50 to 125	°C
T_{STG}	Storage Temperature	-65 to 150	°C
$V_{IO}^{(2)}$	Input or Output Voltage (except A9)	-2 to 7	V
V_{CC}	Supply Voltage	-2 to 7	V
$V_{A9}^{(2)}$	A9 Voltage	-2 to 13.5	V
V_{PP}	Program Supply Voltage	-2 to 14	V

1. Minimum DC voltage on Input or Output is -0.5V with possible undershoot to -2.0V for a period less than 20ns. Maximum DC voltage on Output is $V_{CC} + 0.5V$ with possible overshoot to $V_{CC} + 2V$ for a period less than 20ns.

2. Depends on range.

4 DC and AC parameters

This section summarizes the operating and measurement conditions, and the DC and AC characteristics of the device. The parameters in the DC and AC Characteristic tables that follow are derived from tests performed under the Measurement Conditions summarized in the relevant tables. Designers should check that the operating conditions in their circuit match the measurement conditions when relying on the quoted parameters.

Table 5. AC Measurement Conditions⁽¹⁾

Input Rise and Fall Times	≤20ns
Input Pulse Voltages	0.4V to 2.4V
Input and Output Timing Ref. Voltages	0.8 to 2.0V

1. Note that Output Hi-Z is defined as the point where data is no longer driven.

Figure 5. AC Testing Input Output Waveform

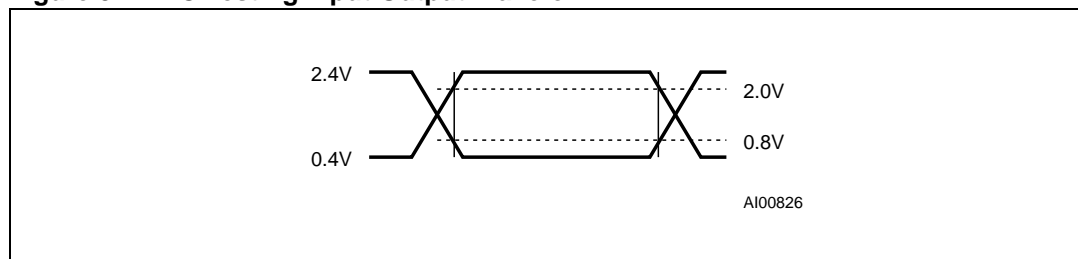

Figure 6. AC Testing Load Circuit

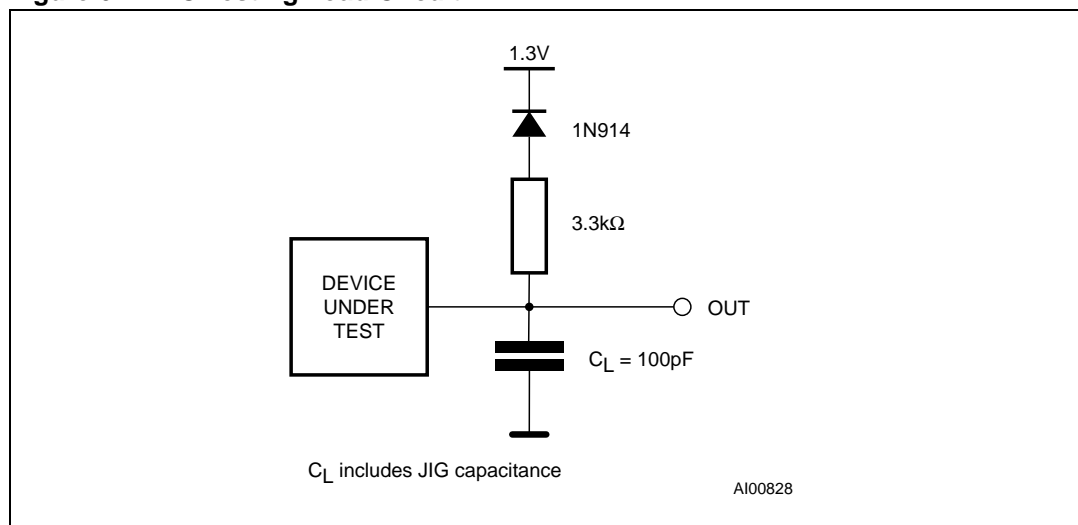

Table 6. Capacitance⁽¹⁾⁽²⁾

Symbol	Parameter	Test Condition	Min	Max	Unit
C _{IN}	Input Capacitance	V _{IN} = 0V		6	pF
C _{OUT}	Output Capacitance	V _{OUT} = 0V		12	pF

1. Sampled only, not 100% tested.
 2. T_A = 25 °C, f = 1 MHz.

Table 7. Read Mode DC Characteristics⁽¹⁾⁽²⁾

Symbol	Parameter	Test Condition	Min	Max	Unit
I_{LI}	Input Leakage Current	$0V \leq V_{IN} \leq V_{CC}$		± 10	μA
I_{LO}	Output Leakage Current	$0V \leq V_{OUT} \leq V_{CC}$		± 10	μA
I_{CC}	Supply Current	$\bar{E} = V_{IL}, \bar{G} = V_{IL}, I_{OUT} = 0mA, f = 5MHz$		30	mA
I_{CC1}	Supply Current (Standby) TTL	$\bar{E} = V_{IH}$		1	mA
I_{CC2}	Supply Current (Standby) CMOS	$\bar{E} > V_{CC} - 0.2V$		100	μA
I_{PP}	Program Current	$V_{PP} = V_{CC}$		100	μA
V_{IL}	Input Low Voltage		-0.3	0.8	V
$V_{IH}^{(3)}$	Input High Voltage		2	$V_{CC} + 1$	V
V_{OL}	Output Low Voltage	$I_{OL} = 2.1mA$		0.4	V
V_{OH}	Output High Voltage TTL	$I_{OH} = -400\mu A$	2.4		V
	Output High Voltage CMOS	$I_{OH} = -100\mu A$		$V_{CC} - 0.7V$	

- $T_A = 0$ to 70 °C or -40 to 85 °C; $V_{CC} = 5V \pm 10\%$; $V_{PP} = V_{CC}$.
- V_{CC} must be applied simultaneously with or before V_{PP} and removed simultaneously or after V_{PP} .
- Maximum DC voltage on Output is $V_{CC} + 0.5V$.

Table 8. Programming Mode DC Characteristics⁽¹⁾⁽²⁾

Symbol	Parameter	Test Condition	Min	Max	Unit
I_{LI}	Input Leakage Current	$V_{IL} \leq V_{IN} \leq V_{IH}$		± 10	μA
I_{CC}	Supply Current			30	mA
I_{PP}	Program Current	$\bar{E} = V_{IL}$		30	mA
V_{IL}	Input Low Voltage		-0.3	0.8	V
V_{IH}	Input High Voltage		2	$V_{CC} + 0.5$	V
V_{OL}	Output Low Voltage	$I_{OL} = 2.1mA$		0.4	V
V_{OH}	Output High Voltage TTL	$I_{OH} = -400\mu A$	2.4		V
V_{ID}	A9 Voltage		11.5	12.5	V

- $T_A = 25$ °C; $V_{CC} = 6V \pm 0.25V$; $V_{PP} = 12.5V \pm 0.25V$.
- V_{CC} must be applied simultaneously with or before V_{PP} and removed simultaneously or after V_{PP} .

Table 9. Read Mode AC Characteristics 1⁽¹⁾⁽²⁾

Symbol	Alt	Parameter	Test Condition	M27C64A						Unit
				-10		-15		-20		
				Min	Max	Min	Max	Min	Max	
t_{AVQV}	t_{ACC}	Address Valid to Output Valid	$\bar{E} = V_{IL}, \bar{G} = V_{IL}$		100		150		200	ns
t_{ELQV}	t_{CE}	Chip Enable Low to Output Valid	$\bar{G} = V_{IL}$		100		150		200	ns
t_{GLQV}	t_{OE}	Output Enable Low to Output Valid	$\bar{E} = V_{IL}$		50		75		80	ns
$t_{EHQZ}^{(3)}$	t_{DF}	Chip Enable High to Output Hi-Z	$\bar{G} = V_{IL}$	0	50	0	50	0	50	ns
$t_{GHQZ}^{(3)}$	t_{DF}	Output Enable High to Output Hi-Z	$\bar{E} = V_{IL}$	0	50	0	50	0	50	ns
t_{AXQX}	t_{OH}	Address Transition to Output Transition	$\bar{E} = V_{IL}, \bar{G} = V_{IL}$	0		0		0		ns

- $T_A = 0$ to 70 °C or -40 to 85 °C: $V_{CC} = 5V \pm 10\%$; $V_{PP} = V_{CC}$.
- V_{CC} must be applied simultaneously with or before V_{PP} and removed simultaneously or after V_{PP} .
- Sampled only, not 100% tested.

Table 10. Read Mode AC Characteristics 2⁽¹⁾⁽²⁾

Symbol	Alt	Parameter	Test Condition	M27C64A				Unit
				-25		-30		
				Min	Max	Min	Max	
t_{AVQV}	t_{ACC}	Address Valid to Output Valid	$\bar{E} = V_{IL}, \bar{G} = V_{IL}$		250		300	ns
t_{ELQV}	t_{CE}	Chip Enable Low to Output Valid	$\bar{G} = V_{IL}$		250		300	ns
t_{GLQV}	t_{OE}	Output Enable Low to Output Valid	$\bar{E} = V_{IL}$		100		120	ns
$t_{EHQZ}^{(3)}$	t_{DF}	Chip Enable High to Output Hi-Z	$\bar{G} = V_{IL}$	0	60	0	105	ns
$t_{GHQZ}^{(3)}$	t_{DF}	Output Enable High to Output Hi-Z	$\bar{E} = V_{IL}$	0	60	0	105	ns
t_{AXQX}	t_{OH}	Address Transition to Output Transition	$\bar{E} = V_{IL}, \bar{G} = V_{IL}$	0		0		ns

- $T_A = 0$ to 70 °C or -40 to 85 °C: $V_{CC} = 5V \pm 10\%$; $V_{PP} = V_{CC}$.
- V_{CC} must be applied simultaneously with or before V_{PP} and removed simultaneously or after V_{PP} .
- Sampled only, not 100% tested.

Figure 7. Read Mode AC Waveforms

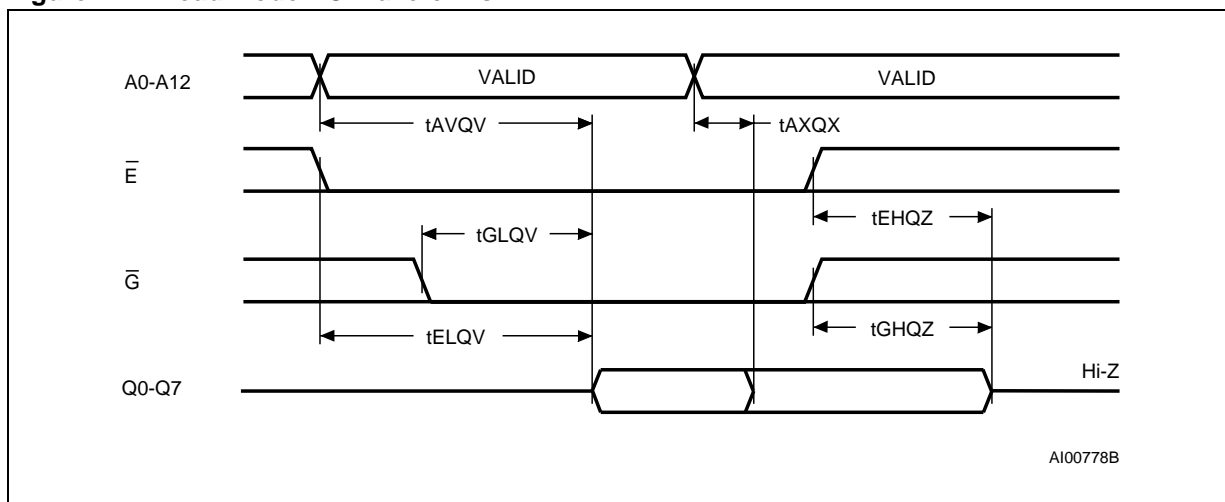
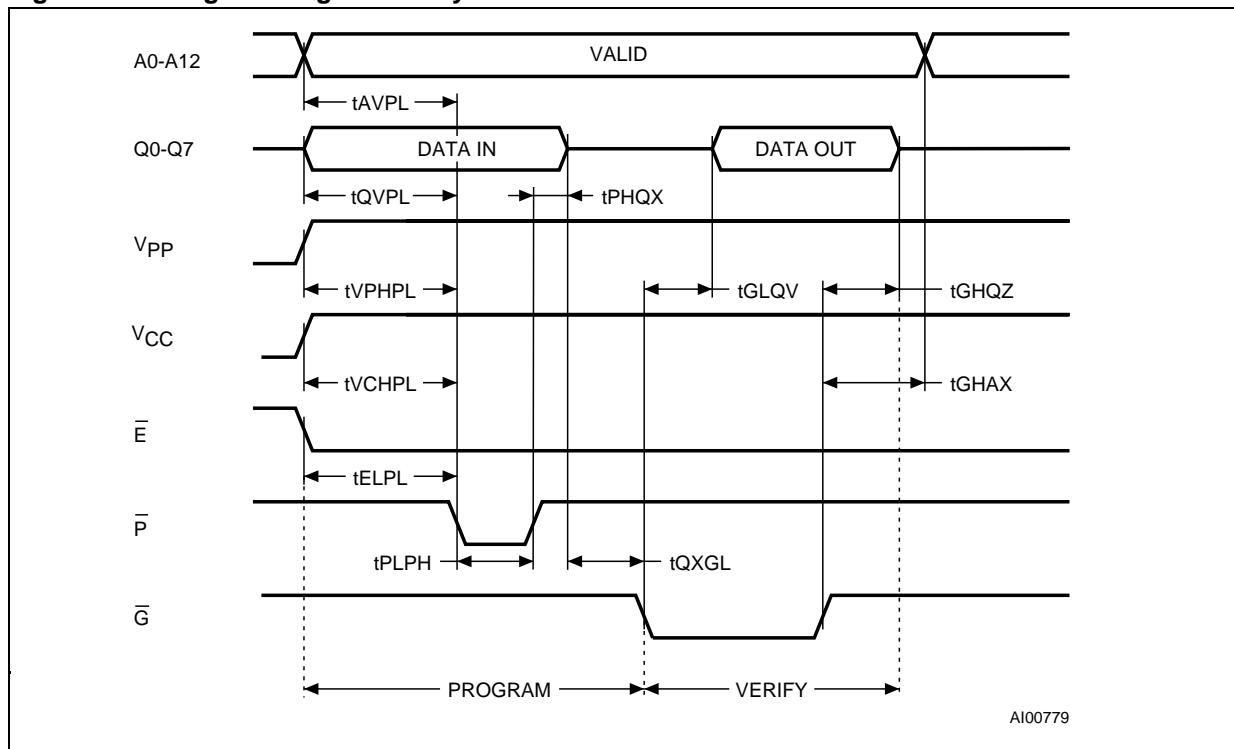

Table 11. Programming Mode AC Characteristics⁽¹⁾⁽²⁾

Symbol	Alt	Parameter	Test Condition	Min	Max	Unit
t_{AVPL}	t_{AS}	Address Valid to Program Low		2		μs
t_{QVPL}	t_{DS}	Input Valid to Program Low		2		μs
t_{VPHPL}	t_{VPS}	V_{PP} High to Program Low		2		μs
t_{VCHPL}	t_{VCS}	V_{CC} High to Program Low		2		μs
t_{ELPL}	t_{CES}	Chip Enable Low to Program Low		2		μs
t_{PLPH}	t_{PW}	Program Pulse Width (Initial)		0.95	1.05	ms
		Program Pulse Width (Over Program)		2.85	78.75	ms
t_{PHQX}	t_{DH}	Program High to Input Transition		2		μs
t_{QXGL}	t_{OES}	Input Transition to Output Enable Low		2		μs
t_{GLQV}	t_{OE}	Output Enable Low to Output Valid			100	ns
$t_{GHQZ}^{(3)}$	t_{DFP}	Output Enable High to Output Hi-Z		0	130	ns
t_{GHAX}	t_{AH}	Output Enable High to Address Transition		0		ns

1. $T_A = 25\text{ }^\circ\text{C}$; $V_{CC} = 6V \pm 0.25V$; $V_{PP} = 12.5V \pm 0.25V$.
2. V_{CC} must be applied simultaneously with or before V_{PP} and removed simultaneously or after V_{PP} .
3. Sampled only, not 100% tested.

Figure 8. Programming and Verify Modes AC Waveforms



5 Package mechanical data

Figure 9. FDIP28W - 28 pin Ceramic Frit-seal DIP, with window, Package Outline

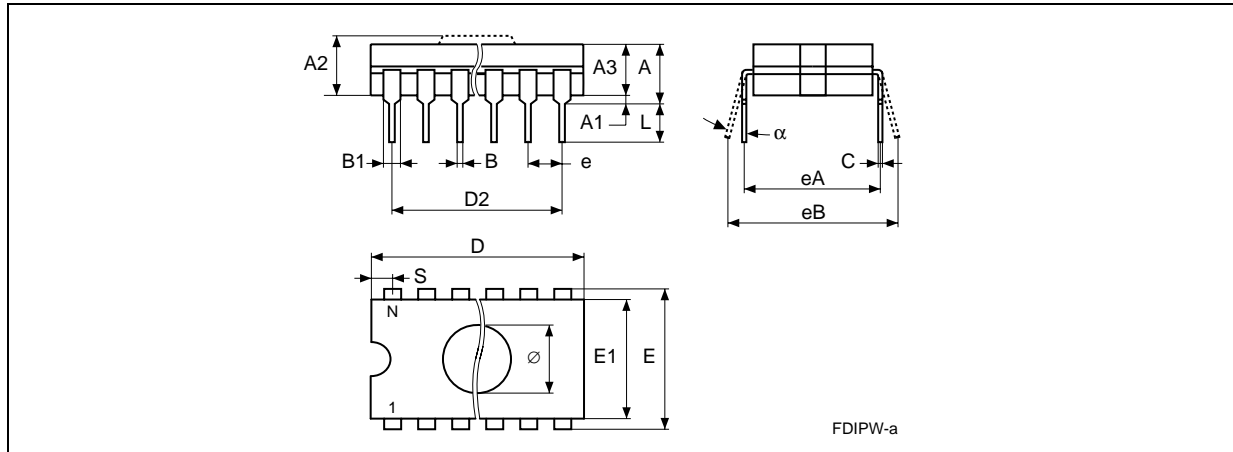

1. Drawing is not to scale.

Table 12. FDIP28W - 28 pin Ceramic Frit-seal DIP, with window, Package Mechanical Data

Symbol	millimeters			inches			
	Typ	Min	Max	Typ	Min	Max	
A			5.72			0.225	
A1		0.51	1.40		0.020	0.055	
A2		3.91	4.57		0.154	0.180	
A3		3.89	4.50		0.153	0.177	
B		0.41	0.56		0.016	0.022	
B1	1.45	–	–	0.057	–	–	
C		0.23	0.30		0.009	0.012	
D		36.50	37.34		1.437	1.470	
D2	33.02	–	–	1.300	–	–	
E	15.24	–	–	0.600	–	–	
E1		13.06	13.36		0.514	0.526	
e	2.54	–	–	0.100	–	–	
eA	14.99	–	–	0.590	–	–	
eB		16.18	18.03		0.637	0.710	
L		3.18	4.10		0.125	0.161	
S		1.52	2.49		0.060	0.098	
∅	7.11	–	–	0.280	–	–	
α		4°	11°		4°	11°	
N		28				28	

Figure 10. PLCC32 - 32 lead Plastic Leaded Chip Carrier, Package Outline

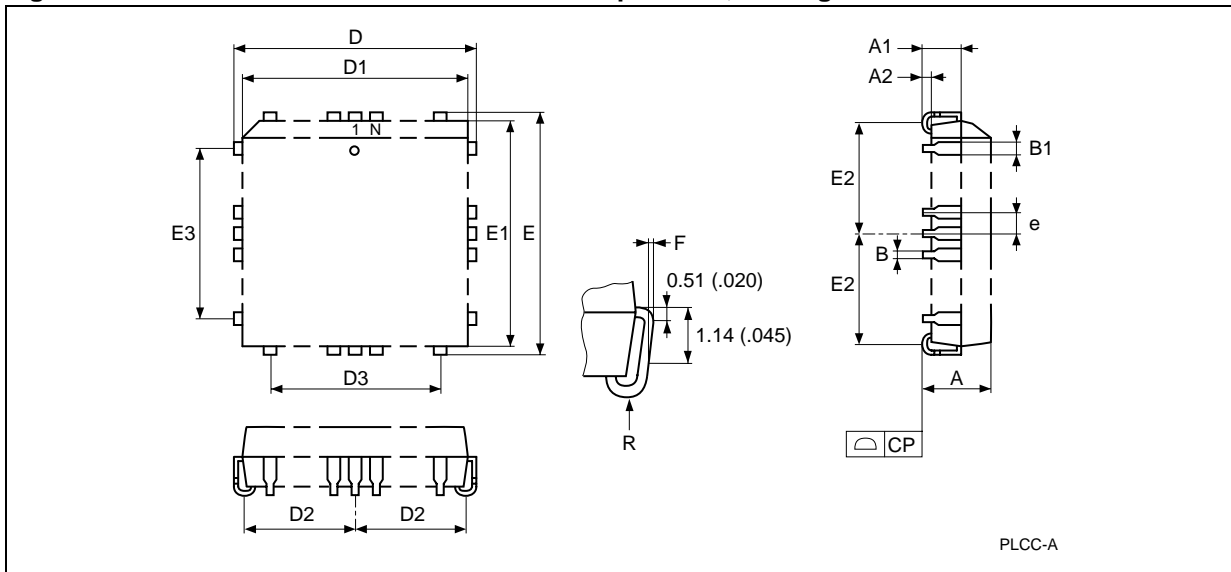

1. Drawing is not to scale.

Table 13. PLCC32 - 32 lead Plastic Leaded Chip Carrier, mechanical data

Symbol	millimeters			inches		
	Typ	Min	Max	Typ	Min	Max
A		3.18	3.56		0.125	0.140
A1		1.53	2.41		0.060	0.095
A2		0.38	–		0.015	–
B		0.33	0.53		0.013	0.021
B1		0.66	0.81		0.026	0.032
CP			0.10			0.004
D		12.32	12.57		0.485	0.495
D1		11.35	11.51		0.447	0.453
D2		4.78	5.66		0.188	0.223
D3	7.62	–	–	0.300	–	–
E		14.86	15.11		0.585	0.595
E1		13.89	14.05		0.547	0.553
E2		6.05	6.93		0.238	0.273
E3	10.16	–	–	0.400	–	–
e	1.27	–	–	0.050	–	–
F		0.00	0.13		0.000	0.005
R	0.89	–	–	0.035	–	–
N	32			32		

6 Part numbering

Table 14. Ordering Information Scheme

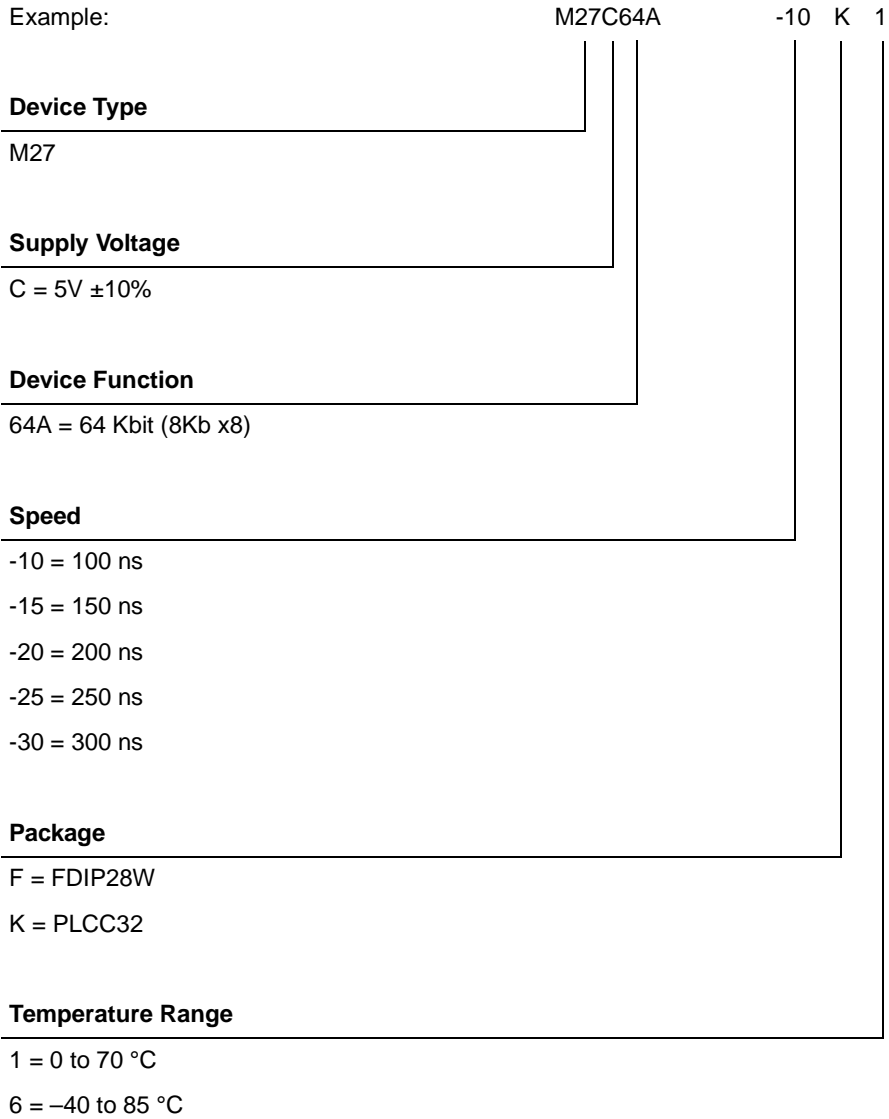

For a list of available options (Speed, Package, etc...) or for further information on any aspect of this device, please contact the STMicroelectronics Sales Office nearest to you.

7 Revision history

Table 15. Document revision history

Date	Revision	Changes
March 1998	1.0	First Issue
25-Sep-2000	2.0	AN620 Reference removed
29-Oct-2002	2.1	100ns speed class added FDIP28W mechanical data clarified (Table 12) PLCC32 mechanical data and drawing clarified (Table 13 , Figure 10)
06-Apr-2006	3	Datasheet converted to new corporate template. Packages are ECOPACK® compliant. Tape & Reel and Additional Burn-in options removed from Table 14: Ordering Information Scheme .

Please Read Carefully:

Information in this document is provided solely in connection with ST products. STMicroelectronics NV and its subsidiaries ("ST") reserve the right to make changes, corrections, modifications or improvements, to this document, and the products and services described herein at any time, without notice.

All ST products are sold pursuant to ST's terms and conditions of sale.

Purchasers are solely responsible for the choice, selection and use of the ST products and services described herein, and ST assumes no liability whatsoever relating to the choice, selection or use of the ST products and services described herein.

No license, express or implied, by estoppel or otherwise, to any intellectual property rights is granted under this document. If any part of this document refers to any third party products or services it shall not be deemed a license grant by ST for the use of such third party products or services, or any intellectual property contained therein or considered as a warranty covering the use in any manner whatsoever of such third party products or services or any intellectual property contained therein.

UNLESS OTHERWISE SET FORTH IN ST'S TERMS AND CONDITIONS OF SALE ST DISCLAIMS ANY EXPRESS OR IMPLIED WARRANTY WITH RESPECT TO THE USE AND/OR SALE OF ST PRODUCTS INCLUDING WITHOUT LIMITATION IMPLIED WARRANTIES OF MERCHANTABILITY, FITNESS FOR A PARTICULAR PURPOSE (AND THEIR EQUIVALENTS UNDER THE LAWS OF ANY JURISDICTION), OR INFRINGEMENT OF ANY PATENT, COPYRIGHT OR OTHER INTELLECTUAL PROPERTY RIGHT.

UNLESS EXPRESSLY APPROVED IN WRITING BY AN AUTHORIZED REPRESENTATIVE OF ST, ST PRODUCTS ARE NOT DESIGNED, AUTHORIZED OR WARRANTED FOR USE IN MILITARY, AIR CRAFT, SPACE, LIFE SAVING, OR LIFE SUSTAINING APPLICATIONS, NOR IN PRODUCTS OR SYSTEMS, WHERE FAILURE OR MALFUNCTION MAY RESULT IN PERSONAL INJURY, DEATH, OR SEVERE PROPERTY OR ENVIRONMENTAL DAMAGE.

Resale of ST products with provisions different from the statements and/or technical features set forth in this document shall immediately void any warranty granted by ST for the ST product or service described herein and shall not create or extend in any manner whatsoever, any liability of ST.

ST and the ST logo are trademarks or registered trademarks of ST in various countries.

Information in this document supersedes and replaces all information previously supplied.

The ST logo is a registered trademark of STMicroelectronics. All other names are the property of their respective owners.

© 2006 STMicroelectronics - All rights reserved

STMicroelectronics group of companies

Australia - Belgium - Brazil - Canada - China - Czech Republic - Finland - France - Germany - Hong Kong - India - Israel - Italy - Japan - Malaysia - Malta - Morocco - Singapore - Spain - Sweden - Switzerland - United Kingdom - United States of America

www.st.com