

LT1054 SWITCHED-CAPACITOR VOLTAGE CONVERTERS WITH REGULATORS

SLVS033F – FEBRUARY 1990 – REVISED NOVEMBER 2004

- Output Current . . . 100 mA
- Low Loss . . . 1.1 V at 100 mA
- Operating Range . . . 3.5 V to 15 V
- Reference and Error Amplifier for Regulation
- External Shutdown
- External Oscillator Synchronization
- Devices Can Be Paralleled
- Pin-to-Pin Compatible With the LTC1044/7660

description/ordering information

The LT1054 is a bipolar, switched-capacitor voltage converter with regulator. It provides higher output current and significantly lower voltage losses than previously available converters. An adaptive-switch drive scheme optimizes efficiency over a wide range of output currents. Total voltage drop at 100-mA output current typically is 1.1 V. This applies to the full supply-voltage range of 3.5 V to 15 V. Quiescent current typically is 2.5 mA.

The LT1054 also provides regulation, a feature previously not available in switched-capacitor voltage converters. By adding an external resistive divider, a regulated output can be obtained. This output is regulated against changes in both input voltage and output current. The LT1054 also can be shut down by grounding the feedback terminal. Supply current in shutdown typically is 100 μ A.

The internal oscillator of the LT1054 runs at a nominal frequency of 25 kHz. The oscillator terminal can be used to adjust the switching frequency or to externally synchronize the LT1054.

The LT1054C is characterized for operation over a free-air temperature range of 0°C to 70°C. The LT1054I is characterized for operation over a free-air temperature range of –40°C to 85°C.

**P PACKAGE
(TOP VIEW)**

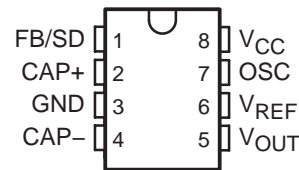

**DW PACKAGE
(TOP VIEW)**

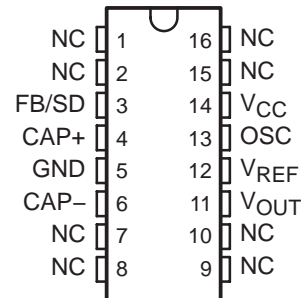

NC – No internal connection

ORDERING INFORMATION

TA	PACKAGE†		ORDERABLE PART NUMBER	TOP-SIDE MARKING
–40°C to 85°C	PDIP (P)	Tube of 50	LT1054IP	LT1054IP
	SOIC (DW)	Tube of 40	LT1054IDW	LT1054I
		Reel of 2000	LT1054IDWR	
0°C to 70°C	PDIP (P)	Tube of 50	LT1054CP	LT1054CP
	SOIC (DW)	Tube of 40	LT1054CDW	LT1054C
		Reel of 2000	LT1054CDWR	

† Package drawings, standard packing quantities, thermal data, symbolization, and PCB design guidelines are available at www.ti.com/sc/package.

LT1054 SWITCHED-CAPACITOR VOLTAGE CONVERTERS WITH REGULATORS

SLVS033F – FEBRUARY 1990 – REVISED NOVEMBER 2004

functional block diagram

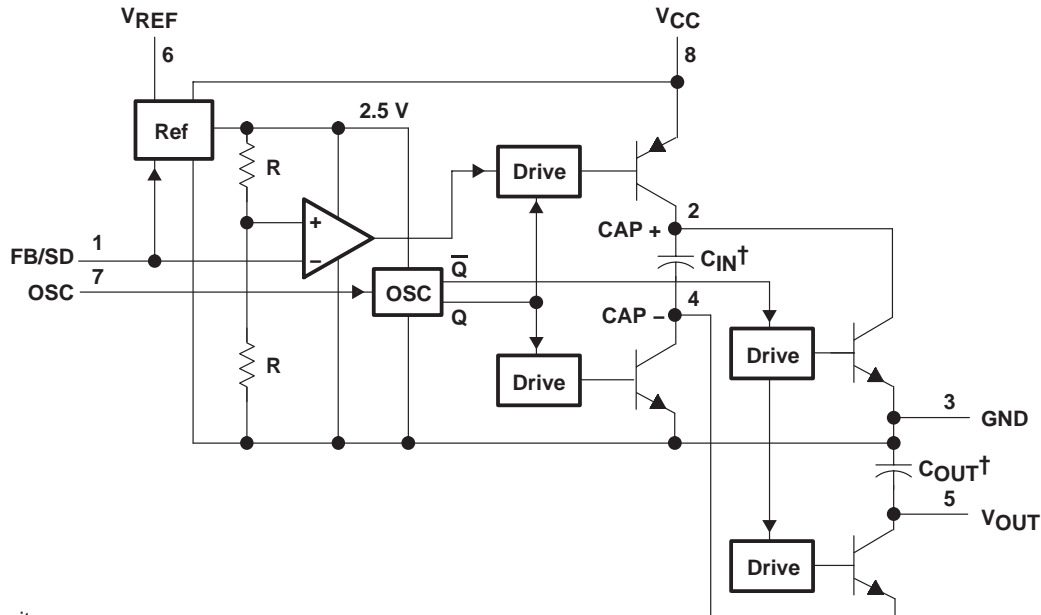

† External capacitors

Pin numbers shown are for the P package.

absolute maximum ratings over operating free-air temperature range (unless otherwise noted)‡

Supply voltage, V_{CC} (see Note 1)	16 V
Input voltage range, V_I : FB/SD	0 V to V_{CC}
OSC	0 V to V_{ref}
Junction temperature, T_J (see Note 2): LT1054C	125°C
LT1054I	135°C
Package thermal impedance, θ_{JA} (see Notes 3 and 4): DW package	57°C/W
P package	85°C/W
Storage temperature range, T_{stg}	-55°C to 150°C

‡ Stresses beyond those listed under “absolute maximum ratings” may cause permanent damage to the device. These are stress ratings only, and functional operation of the device at these or any other conditions beyond those indicated under “recommended operating conditions” is not implied. Exposure to absolute-maximum-rated conditions for extended periods may affect device reliability.

- NOTES: 1. The absolute maximum supply-voltage rating of 16 V is for unregulated circuits. For regulation-mode circuits with $V_{OUT} \leq 15$ V, this rating may be increased to 20 V.
2. The devices are functional up to the absolute maximum junction temperature.
3. Maximum power dissipation is a function of $T_J(\max)$, θ_{JA} , and T_A . The maximum allowable power dissipation at any allowable ambient temperature is $P_D = (T_J(\max) - T_A)/\theta_{JA}$. Operating at the absolute maximum T_J of 150°C can impact reliability.
4. The package thermal impedance is calculated in accordance with JESD 51-7.

recommended operating conditions

		MIN	MAX	UNIT	
V_{CC}	Supply voltage	3.5	15	V	
T_A	Operating free-air temperature range	LT1054C	0	70	°C
		LT1054I	-40	85	



POST OFFICE BOX 655303 • DALLAS, TEXAS 75265

LT1054 SWITCHED-CAPACITOR VOLTAGE CONVERTERS WITH REGULATORS

SLVS033F – FEBRUARY 1990 – REVISED NOVEMBER 2004

electrical characteristics over recommended operating conditions (unless otherwise noted)

PARAMETER	TEST CONDITIONS	T _A †	LT1054C LT1054I			UNIT
			MIN	TYP‡	MAX	
V _O Regulated output voltage	V _{CC} = 7 V, T _J = 25°C, R _L = 500 Ω, See Note 5	25°C	-4.7	-5	-5.2	V
Input regulation	V _{CC} = 7 V to 12 V, R _L = 500 Ω, See Note 5	Full range		5	25	mV
Output regulation	V _{CC} = 7 V, R _L = 100 Ω to 500 Ω, See Note 5	Full range		10	50	mV
Voltage loss, V _{CC} - V _O (see Note 6)	C _I = C _O = 100-μF tantalum	I _O = 10 mA	Full range		0.35 0.55	V
		I _O = 100 mA			1.1 1.6	
Output resistance	ΔI _O = 10 mA to 100 mA, See Note 7	Full range		10	15	Ω
Oscillator frequency	V _{CC} = 3.5 V to 15 V	Full range	15	25	35	kHz
V _{ref} Reference voltage	I _(REF) = 60 μA	25°C	2.35	2.5	2.65	V
		Full range	2.25		2.75	
Maximum switch current		25°C	300			mA
I _{CC} Supply current	I _O = 0	V _{CC} = 3.5 V	Full range		2.5 4	mA
		V _{CC} = 15 V			3 5	
Supply current in shutdown	V _(FB/SD) = 0 V	Full range		100	200	μA

† Full range is 0°C to 70°C for the LT1054C and -40°C to 85°C for the LT1054I.

‡ All typical values are at T_A = 25°C.

- NOTES:
- All regulation specifications are for a device connected as a positive-to-negative converter/regulator with R₁ = 20 kΩ, R₂ = 102.5 kΩ, external capacitor C_{IN} = 10 μF (tantalum), external capacitor C_{OUT} = 100 μF (tantalum) and C₁ = 0.002 μF (see Figure 15).
 - For voltage-loss tests, the device is connected as a voltage inverter, with terminals 1, 6, and 7 unconnected. The voltage losses may be higher in other configurations. C_{IN} and C_{OUT} are external capacitors.
 - Output resistance is defined as the slope of the curve (ΔV_O versus ΔI_O) for output currents of 10 mA to 100 mA. This represents the linear portion of the curve. The incremental slope of the curve is higher at currents less than 10 mA due to the characteristics of the switch transistors.



LT1054
SWITCHED-CAPACITOR VOLTAGE CONVERTERS
WITH REGULATORS

SLVS033F – FEBRUARY 1990 – REVISED NOVEMBER 2004

TYPICAL CHARACTERISTICS

Table of Graphs

	FIGURE
Shutdown threshold voltage vs Free-air temperature	1
Supply current vs Input voltage	2
Oscillator frequency vs Free-air temperature	3
Supply current in shutdown vs Input voltage	4
Average supply current vs Output current	5
Output voltage loss vs Input capacitance	6
Output voltage loss vs Oscillator frequency (10 μ F)	7
Output voltage loss vs Oscillator frequency (100 μ F)	8
Regulated output voltage vs Free-air temperature	9
Reference voltage change vs Free-air temperature	10
Voltage loss vs Output current	11

Table of Figures

	FIGURE
Switched-Capacitor Building Block	12
Switched-Capacitor Equivalent Circuit	13
Circuit With Load Connected From V_{CC} to V_{OUT}	14
External-Clock System	15
Basic Regulation Configuration	16
Power-Dissipation-Limiting Resistor in Series With C_{IN}	17
Motor-Speed Servo	18
Basic Voltage Inverter	19
Basic Voltage Inverter/Regulator	20
Negative-Voltage Doubler	21
Positive-Voltage Doubler	22
100-mA Regulating Negative Doubler	23
Dual-Output Voltage Doubler	24
5-V to \pm 12-V Converter	25
Strain-Gage Bridge Signal Conditioner	26
3.5-V to 5-V Regulator	27
Regulating 200-mA +12-V to -5-V Converter	28
Digitally Programmable Negative Supply	29
Positive Doubler With Regulation (5-V to 8-V Converter)	30
Negative Doubler With Regulator	31



TYPICAL CHARACTERISTICS†

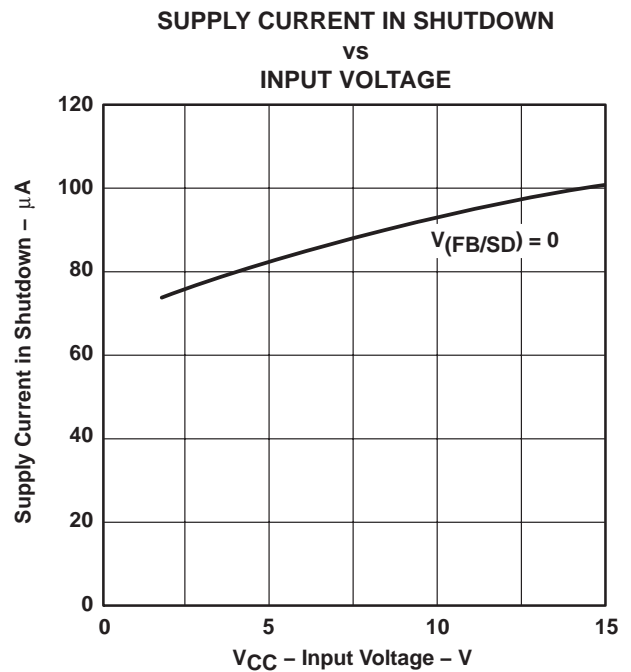
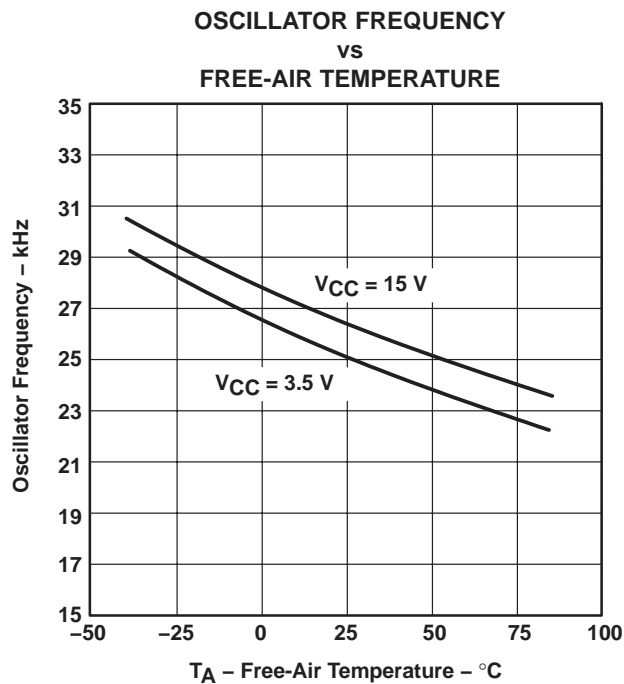
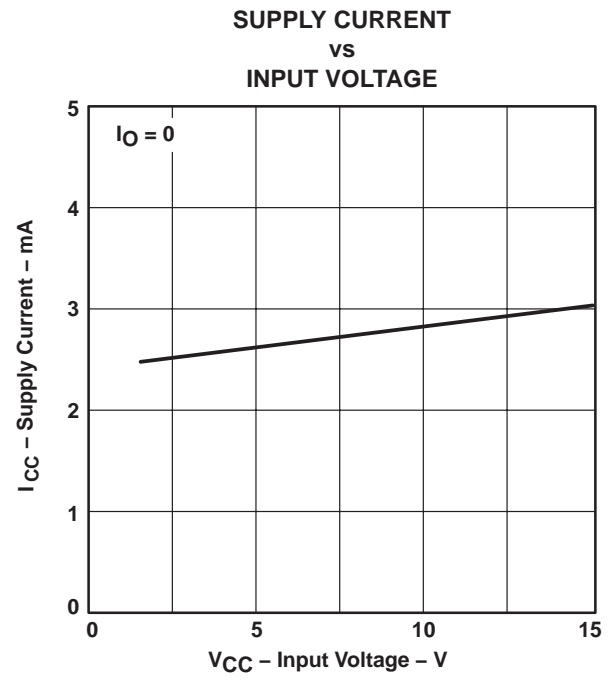
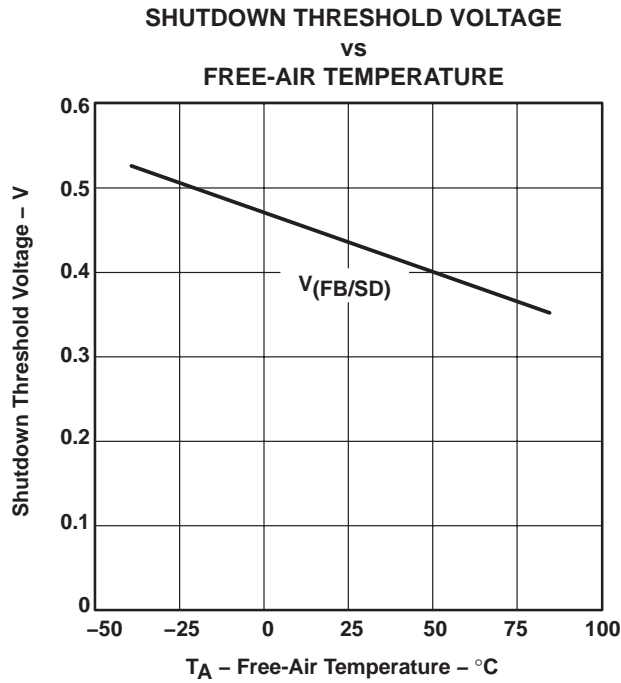

† Data at high and low temperatures are applicable only within the recommended operating free-air temperature range.

LT1054 SWITCHED-CAPACITOR VOLTAGE CONVERTERS WITH REGULATORS

SLVS033F – FEBRUARY 1990 – REVISED NOVEMBER 2004

TYPICAL CHARACTERISTICS

AVERAGE SUPPLY CURRENT
vs
OUTPUT CURRENT

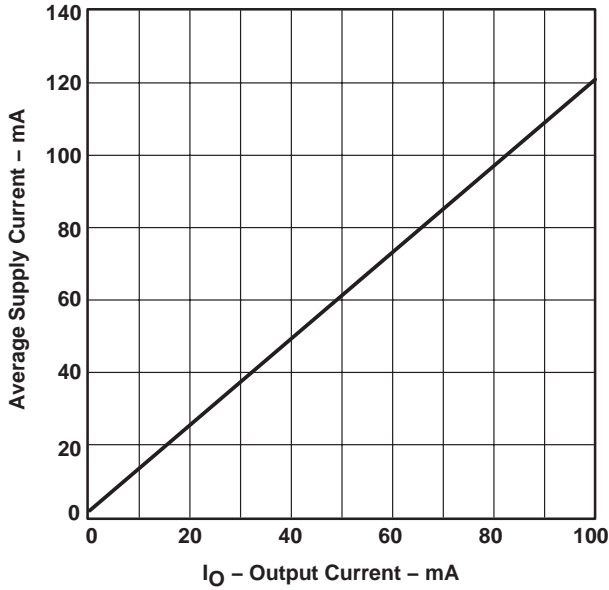

Figure 5

OUTPUT VOLTAGE LOSS
vs
INPUT CAPACITANCE

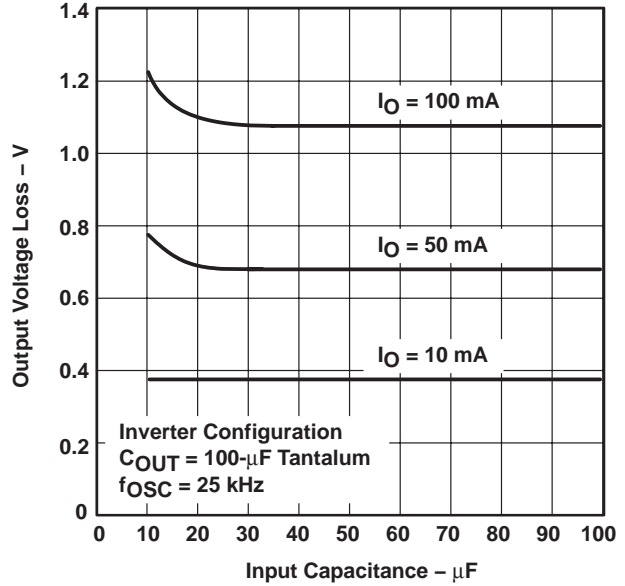

Figure 6

OUTPUT VOLTAGE LOSS
vs
OSCILLATOR FREQUENCY

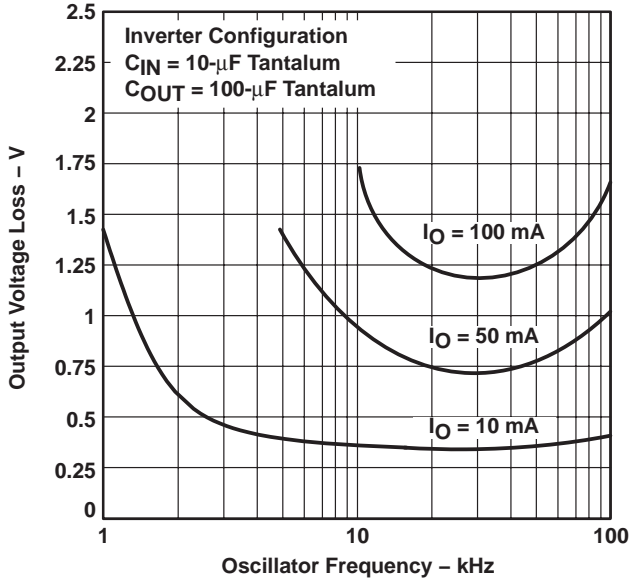

Figure 7

OUTPUT VOLTAGE LOSS
vs
OSCILLATOR FREQUENCY

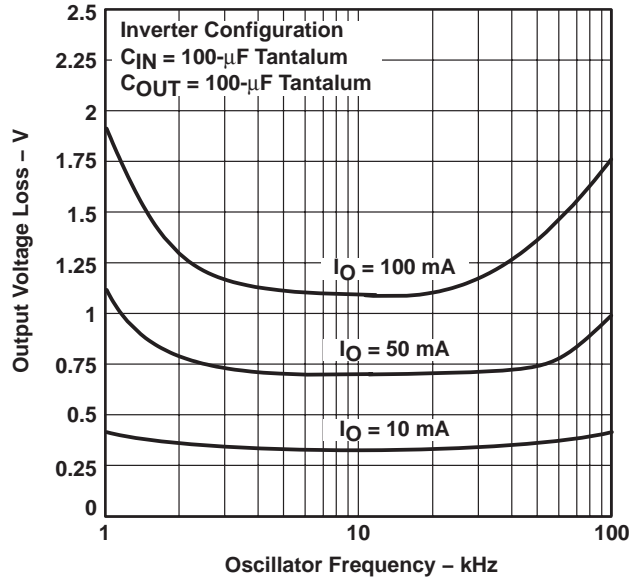
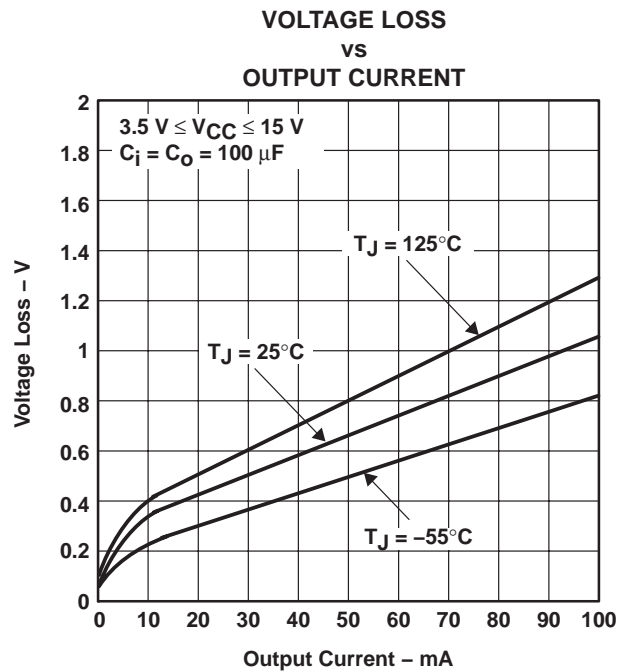
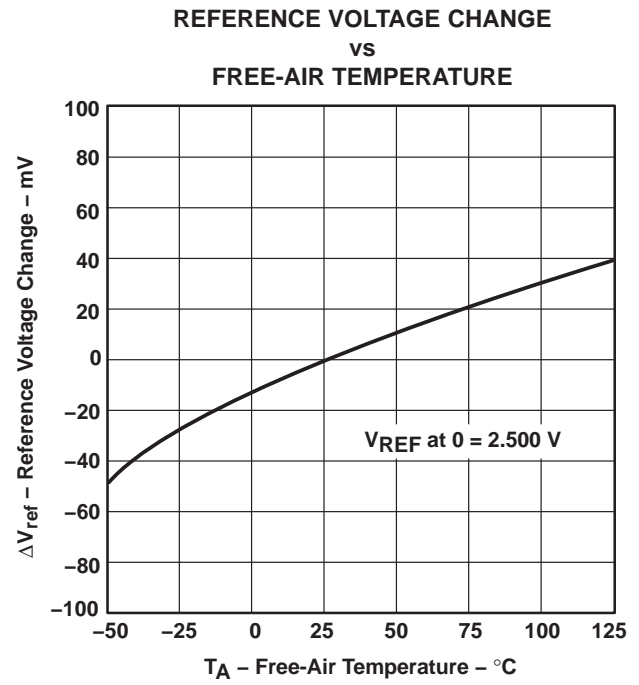
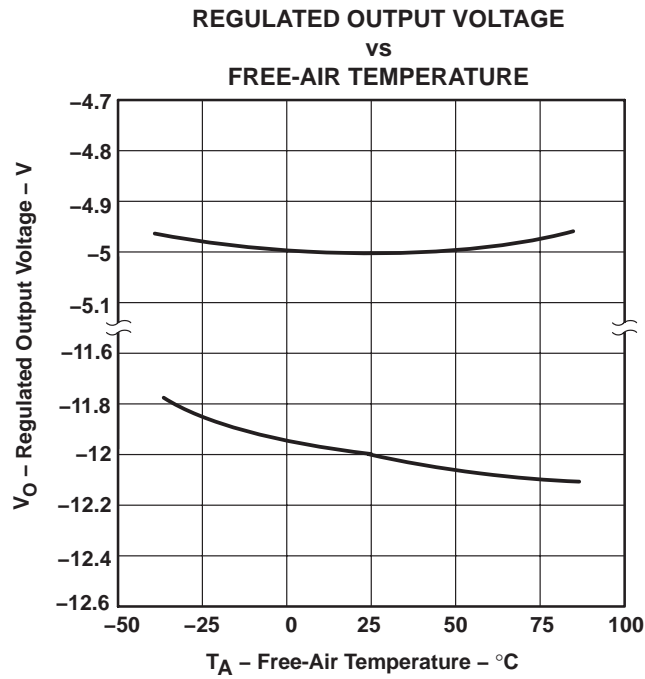

Figure 8

TYPICAL CHARACTERISTICS†



† Data at high and low temperatures are applicable only within the recommended operating free-air temperature range.

LT1054 SWITCHED-CAPACITOR VOLTAGE CONVERTERS WITH REGULATORS

SLVS033F – FEBRUARY 1990 – REVISED NOVEMBER 2004

PRINCIPLES OF OPERATION

A review of a basic switched-capacitor building block is helpful in understanding the operation of the LT1054. When the switch shown in Figure 12 is in the left position, capacitor C1 charges to the voltage at V1. The total charge on C1 is $q_1 = C_1V_1$. When the switch is moved to the right, C1 is discharged to the voltage at V2. After this discharge time, the charge on C1 is $q_2 = C_1V_2$. The charge has been transferred from the source V1 to the output V2. The amount of charge transferred is shown in equation 1.

$$\Delta q = q_1 - q_2 = C_1(V_1 - V_2) \quad (1)$$

If the switch is cycled f times per second, the charge transfer per unit time (i.e., current) is as shown in equation 2.

$$I = f \times \Delta q = f \times C_1(V_1 - V_2) \quad (2)$$

To obtain an equivalent resistance for a switched-capacitor network, this equation can be rewritten in terms of voltage and impedance equivalence as shown in equation 3.

$$I = \frac{V_1 - V_2}{(1/fC_1)} = \frac{V_1 - V_2}{R_{EQUIV}} \quad (3)$$

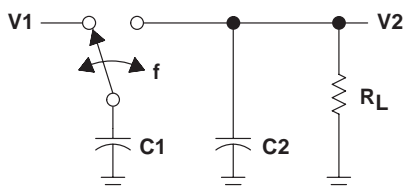

Figure 12. Switched-Capacitor Building Block

A new variable, R_{EQUIV} , is defined as $R_{EQUIV} = 1 \div fC_1$. The equivalent circuit for the switched-capacitor network is shown in Figure 13. The LT1054 has the same switching action as the basic switched-capacitor building block. Even though this simplification does not include finite switch-on resistance and output-voltage ripple, it provides an insight into how the device operates.

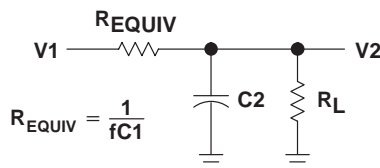

Figure 13. Switched-Capacitor Equivalent Circuit

These simplified circuits explain voltage loss as a function of oscillator frequency (see Figure 7). As oscillator frequency is decreased, the output impedance eventually is dominated by the $1/fC_1$ term, and voltage losses rise.

Voltage losses also rise as oscillator frequency increases. This is caused by internal switching losses that occur due to some finite charge being lost on each switching cycle. This charge loss per-unit-cycle, when multiplied by the switching frequency, becomes a current loss. At high frequency, this loss becomes significant and voltage losses again rise.

The oscillator of the LT1054 is designed to operate in the frequency band where voltage losses are at a minimum.

PRINCIPLES OF OPERATION

Supply voltage V_{CC} alternately charges C_{IN} to the input voltage when C_{IN} is switched in parallel with the input supply and then transfers charge to C_{OUT} when C_{IN} is switched in parallel with C_{OUT} . Switching occurs at the oscillator frequency. During the time that C_{IN} is charging, the peak supply current is approximately 2.2 times the output current. During the time that C_{IN} is delivering a charge to C_{OUT} , the supply current drops to approximately 0.2 times the output current. An input supply bypass capacitor supplies part of the peak input current drawn by the LT1054 and averages the current drawn from the supply. A minimum input-supply bypass capacitor of 2 μ F, preferably tantalum or some other low equivalent-series-resistance (ESR) type, is recommended. A larger capacitor is desirable in some cases. An example of this would be when the actual input supply is connected to the LT1054 through long leads or when the pulse currents drawn by the LT1054 might affect other circuits through supply coupling.

In addition to being the output terminal, V_{OUT} is tied to the substrate of the device. Special care must be taken in LT1054 circuits to avoid making V_{OUT} positive with respect to any of the other terminals. For circuits with the output load connected from V_{CC} to V_{OUT} or from some external positive supply voltage to V_{OUT} , an external transistor must be added (see Figure 14). This transistor prevents V_{OUT} from being pulled above GND during startup. Any small general-purpose transistor such as a 2N2222 or a 2N2219 device can be used. Resistor R1 should be chosen to provide enough base drive to the external transistor so that it is saturated under nominal output voltage and maximum output current conditions.

$$R1 \leq \frac{(V_{OUT})\beta}{I_{OUT}} \quad (4)$$

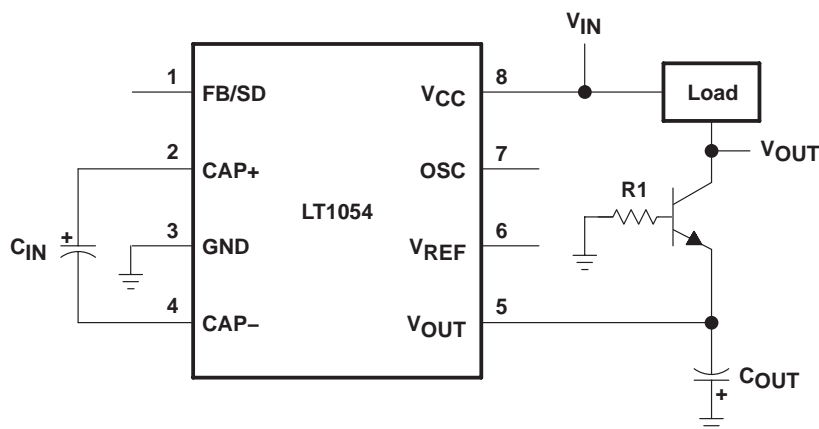

Pin numbers shown are for the P package.

Figure 14. Circuit With Load Connected from V_{CC} to V_{OUT}

LT1054 SWITCHED-CAPACITOR VOLTAGE CONVERTERS WITH REGULATORS

SLVS033F – FEBRUARY 1990 – REVISED NOVEMBER 2004

PRINCIPLES OF OPERATION

The voltage reference (V_{ref}) output provides a 2.5-V reference point for use in LT1054-based regulator circuits. The temperature coefficient (TC) of the reference voltage has been adjusted so that the TC of the regulated output voltage is near zero. As seen in the typical performance curves, this requires the reference output to have a positive TC. This nonzero drift is necessary to offset a drift term inherent in the internal reference divider and comparator network tied to the feedback terminal. The overall result of these drift terms is a regulated output that has a slight positive TC at output voltages below 5 V and a slight negative TC at output voltages above 5 V. For regulator feedback networks, reference output current should be limited to approximately 60 μA . V_{ref} draws approximately 100 μA when shorted to ground and does not affect the internal reference/regulator. This terminal also can be used as a pullup for LT1054 circuits that require synchronization.

CAP+ is the positive side of input capacitor C_{IN} and is driven alternately between V_{CC} and ground. When driven to V_{CC} , CAP+ sources current from V_{CC} . When driven to ground, CAP+ sinks current to ground. CAP- is the negative side of the input capacitor and is driven alternately between ground and V_{OUT} . When driven to ground, CAP- sinks current to ground. When driven to V_{OUT} , CAP- sources current from C_{OUT} . In all cases, current flow in the switches is unidirectional, as should be expected when using bipolar switches.

OSC can be used to raise or lower the oscillator frequency or to synchronize the device to an external clock. Internally, OSC is connected to the oscillator timing capacitor ($C_t \approx 150 \text{ pF}$), which is charged and discharged alternately by current sources of $\pm 7 \mu\text{A}$, so that the duty cycle is approximately 50%. The LT1054 oscillator is designed to run in the frequency band where switching losses are minimized. However, the frequency can be raised, lowered, or synchronized to an external system clock if necessary.

The frequency can be increased by adding an external capacitor (C_2 in Figure 15) in the range of 5–20 pF from CAP+ to OSC. This capacitor couples a charge into C_t at the switch transitions. This shortens the charge and discharge times and raises the oscillator frequency. Synchronization can be accomplished by adding an external pullup resistor from OSC to V_{ref} . A 20-k Ω pullup resistor is recommended. An open-collector gate or an npn transistor then can be used to drive OSC at the external clock frequency as shown in Figure 15.

The frequency can be lowered by adding an external capacitor (C_1 in Figure 15) from OSC to ground. This increases the charge and discharge times, which lowers the oscillator frequency.

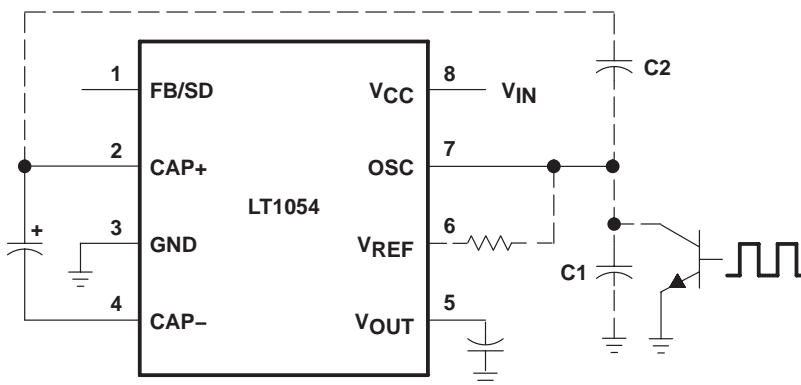

Pin numbers shown are for the P package.

Figure 15. External-Clock System

APPLICATION INFORMATION

regulation

The feedback/shutdown (FB/SD) terminal has two functions. Pulling FB/SD below the shutdown threshold (≈ 0.45 V) puts the device into shutdown. In shutdown, the reference/regulator is turned off and switching stops. The switches are set such that both C_{IN} and C_{OUT} are discharged through the output load. Quiescent current in shutdown drops to approximately $100 \mu\text{A}$. Any open-collector gate can be used to put the LT1054 into shutdown. For normal (unregulated) operation, the device will restart when the external gate is shut off. In LT1054 circuits that use the regulation feature, the external resistor divider can provide enough pulldown to keep the device in shutdown until the output capacitor (C_{OUT}) has fully discharged. For most applications, where the LT1054 is run intermittently, this does not present a problem because the discharge time of the output capacitor is short compared to the off time of the device. In applications where the device has to start up before the output capacitor (C_{OUT}) has fully discharged, a restart pulse must be applied to FB/SD of the LT1054. Using the circuit shown in Figure 16, the restart signal can be either a pulse ($t_p > 100 \mu\text{s}$) or a logic high. Diode coupling the restart signal into FB/SD allows the output voltage to rise and regulate without overshoot. The resistor divider $R3/R4$ shown in Figure 16 should be chosen to provide a signal level at FB/SD of $0.7\text{--}1.1$ V.

FB/SD also is the inverting input of the LT1054 error amplifier and, as such, can be used to obtain a regulated output voltage.

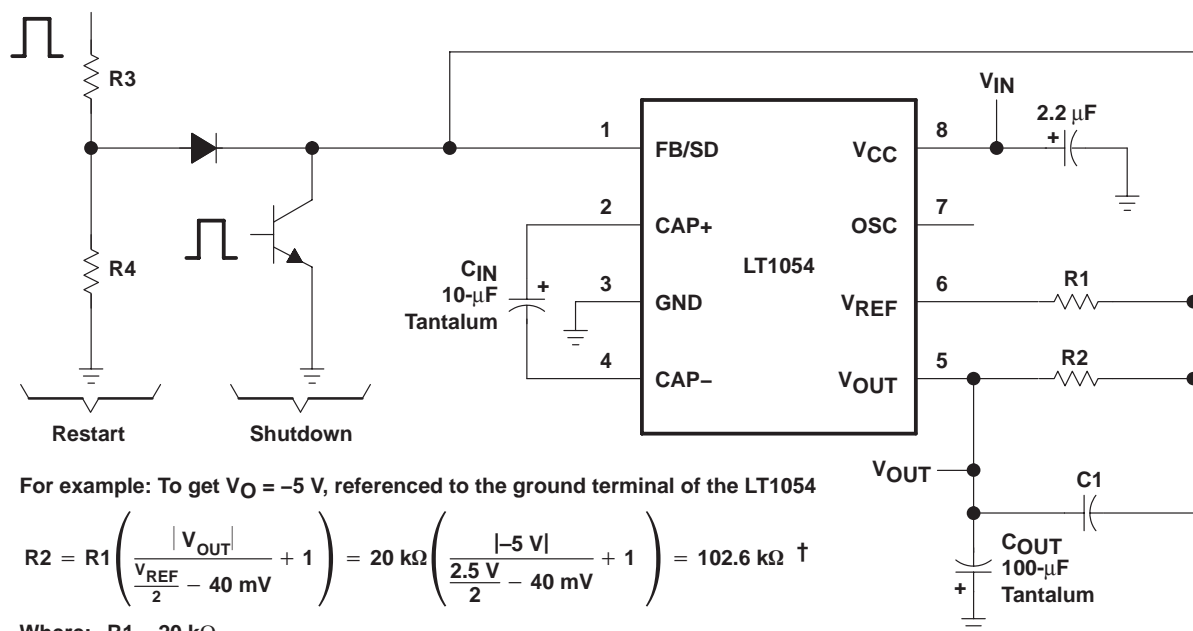

For example: To get $V_O = -5$ V, referenced to the ground terminal of the LT1054

$$R2 = R1 \left(\frac{|V_{OUT}|}{\frac{V_{REF}}{2} - 40 \text{ mV}} + 1 \right) = 20 \text{ k}\Omega \left(\frac{|-5 \text{ V}|}{\frac{2.5 \text{ V}}{2} - 40 \text{ mV}} + 1 \right) = 102.6 \text{ k}\Omega \dagger$$

Where: $R1 = 20 \text{ k}\Omega$
 $V_{REF} = 2.5 \text{ V Nominal}$

† Choose the closest 1% value.

Pin numbers shown are for the P package.

Figure 16. Basic Regulation Configuration

LT1054 SWITCHED-CAPACITOR VOLTAGE CONVERTERS WITH REGULATORS

SLVS033F – FEBRUARY 1990 – REVISED NOVEMBER 2004

APPLICATION INFORMATION

regulation (continued)

The error amplifier of the LT1054 drives the pnp switch to control the voltage across the input capacitor (C_{IN}), which determines the output voltage. When the reference and error amplifier of the LT1054 are used, an external resistive divider is all that is needed to set the regulated output voltage. Figure 16 shows the basic regulator configuration and the formula for calculating the appropriate resistor values. R1 should be 20 k Ω or greater because the reference current is limited to $\pm 100 \mu\text{A}$. R2 should be in the range of 100 k Ω to 300 k Ω . Frequency compensation is accomplished by adjusting the ratio of C_{IN} to C_{OUT} .

For best results, this ratio should be approximately 1:10. Capacitor C1, required for good load regulation, should be 0.002 μF for all output voltages.

The functional block diagram shows that the maximum regulated output voltage is limited by the supply voltage. For the basic configuration, $|V_{OUT}|$ referenced to the ground terminal of the LT1054 must be less than the total of the supply voltage minus the voltage loss due to the switches. The voltage loss versus output current due to the switches can be found in the typical performance curves. Other configurations, such as the negative doubler, can provide higher voltages at reduced output currents.

capacitor selection

While the exact values of C_{IN} and C_{OUT} are noncritical, good-quality low-ESR capacitors, such as solid tantalum, are necessary to minimize voltage losses at high currents. For C_{IN} , the effect of the ESR of the capacitor is multiplied by four, because switch currents are approximately two times higher than output current. Losses occur on both the charge and discharge cycle, which means that a capacitor with 1 Ω of ESR for C_{IN} has the same effect as increasing the output impedance of the LT1054 by 4 Ω . This represents a significant increase in the voltage losses. C_{OUT} alternately is charged and discharged at a current approximately equal to the output current. The ESR of the capacitor causes a step function to occur in the output ripple at the switch transitions. This step function degrades the output regulation for changes in output load current and should be avoided. A technique used to gain both low ESR and reasonable cost is to parallel a smaller tantalum capacitor with a large aluminum electrolytic capacitor.

output ripple

The peak-to-peak output ripple is determined by the output capacitor and the output current values. Peak-to-peak output ripple is approximated as:

$$\Delta V = \frac{I_{OUT}}{2fC_{OUT}} \quad (5)$$

Where:

ΔV = peak-to-peak ripple
 f_{OSC} = oscillator frequency

For output capacitors with significant ESR, a second term must be added to account for the voltage step at the switch transitions. This step is approximately equal to:

$$(2I_{OUT})(\text{ESR of } C_{OUT}) \quad (6)$$

APPLICATION INFORMATION

power dissipation

The power dissipation of any LT1054 circuit must be limited so that the junction temperature of the device does not exceed the maximum junction-temperature ratings. The total power dissipation is calculated from two components—the power loss due to voltage drops in the switches, and the power loss due to drive-current losses. The total power dissipated by the LT1054 is calculated as:

$$P \approx (V_{CC} - |V_{OUT}|) I_{OUT} + (V_{CC})(I_{OUT})(0.2) \quad (7)$$

where both V_{CC} and V_{OUT} are referenced to ground. The power dissipation is equivalent to that of a linear regulator. Limited power-handling capability of the LT1054 packages causes limited output-current requirements, or steps can be taken to dissipate power external to the LT1054 for large input or output differentials. This is accomplished by placing a resistor in series with C_{IN} as shown in Figure 17. A portion of the input voltage is dropped across this resistor without affecting the output regulation. Since switch current is approximately 2.2 times the output current and the resistor causes a voltage drop when C_{IN} is both charging and discharging, the resistor chosen is as shown:

$$R_x = \frac{V_x}{4.4 I_{OUT}} \quad (8)$$

Where:

$$V_x \approx V_{CC} - [(LT1054 \text{ voltage loss})(1.3) + |V_{OUT}|]$$

and

$$I_{OUT} = \text{maximum required output current}$$

The factor of 1.3 allows some operating margin for the LT1054.

When using a 12-V to –5-V converter at 100-mA output current, calculate the power dissipation without an external resistor.

$$P = (12 \text{ V} - |-5 \text{ V}|)(100 \text{ mA}) + (12 \text{ V})(100 \text{ mA})(0.2)$$

$$P = 700 \text{ mW} + 240 \text{ mW} = 940 \text{ mW} \quad (9)$$

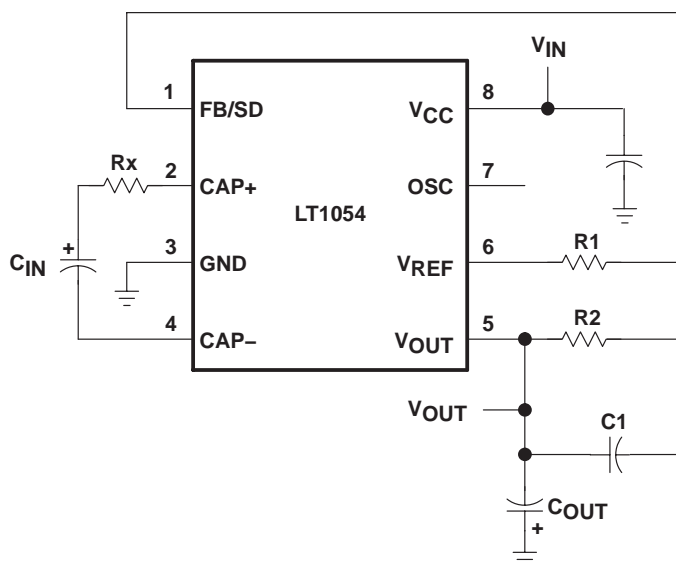

Pin numbers shown are for the P package.

Figure 17. Power-Dissipation-Limiting Resistor in Series With C_{IN}

LT1054 SWITCHED-CAPACITOR VOLTAGE CONVERTERS WITH REGULATORS

SLVS033F – FEBRUARY 1990 – REVISED NOVEMBER 2004

APPLICATION INFORMATION

power dissipation (continued)

At $R_{\theta JA}$ of $130^{\circ}\text{C}/\text{W}$ for a commercial plastic device, a junction temperature rise of 122°C occurs. The device exceeds the maximum junction temperature at an ambient temperature of 25°C . To calculate the power dissipation with an external resistor (R_X), determine how much voltage can be dropped across R_X . The maximum voltage loss of the LT1054 in the standard regulator configuration at 100 mA output current is 1.6 V.

$$V_X = 12\text{ V} - [(1.6\text{ V})(1.3) + |-5\text{ V}|] = 4.9\text{ V} \quad (10)$$

and

$$R_X = \frac{4.9\text{ V}}{(4.4)(100\text{ mA})} = 11\ \Omega \quad (11)$$

The resistor reduces the power dissipated by the LT1054 by $(4.9\text{ V})(100\text{ mA}) = 490\text{ mW}$. The total power dissipated by the LT1054 is equal to $(940\text{ mW} - 490\text{ mW}) = 450\text{ mW}$. The junction-temperature rise is 58°C . Although commercial devices are functional up to a junction temperature of 125°C , the specifications are tested to a junction temperature of 100°C . In this example, this means limiting the ambient temperature to 42°C . To allow higher ambient temperatures, the thermal resistance numbers for the LT1054 packages represent worst-case numbers, with no heat sinking and still air. Small clip-on heat sinks can be used to lower the thermal resistance of the LT1054 package. Airflow in some systems helps to lower the thermal resistance. Wide printed circuit board traces from the LT1054 leads help remove heat from the device. This is especially true for plastic packages.

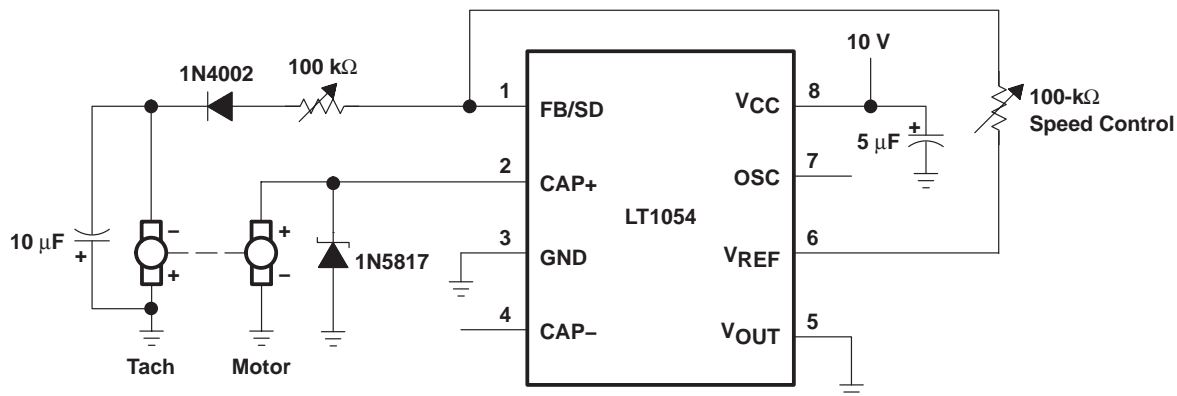

NOTE: Motor-Tach is Canon CKT26-T5-3SAE.
Pin numbers shown are for the P package.

Figure 18. Motor-Speed Servo

APPLICATION INFORMATION

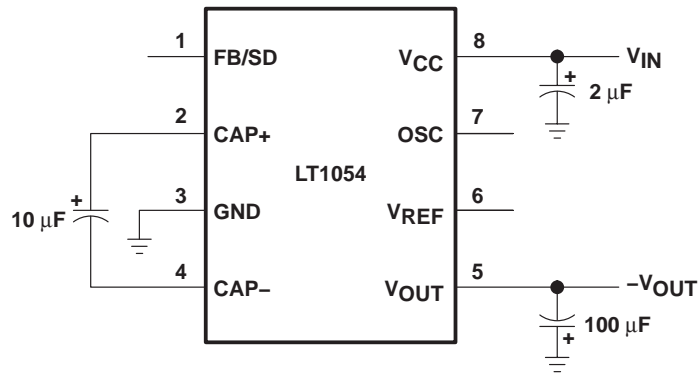

Pin numbers shown are for the P package.

Figure 19. Basic Voltage Inverter

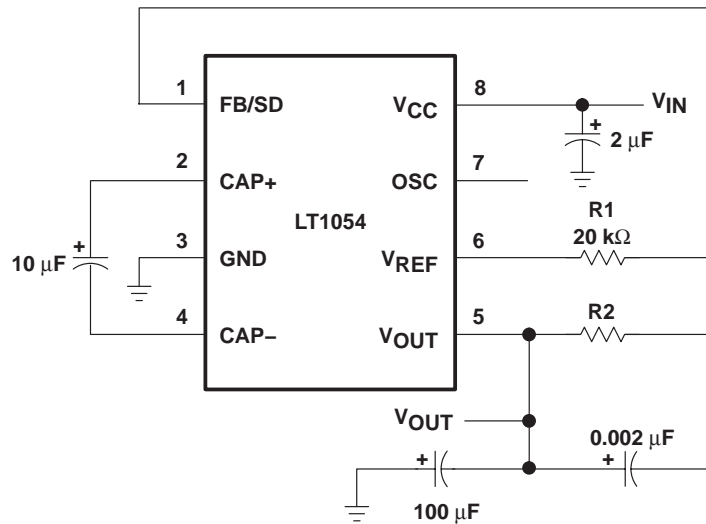

$$R2 = R1 \left(\frac{|V_{OUT}|}{\frac{V_{REF}}{2} - 40 \text{ mV}} + 1 \right) = 20 \text{ k}\Omega \left(\frac{|V_{OUT}|}{1.21 \text{ V}} + 1 \right)$$

Pin numbers shown are for the P package.

Figure 20. Basic Voltage Inverter/Regulator

LT1054 SWITCHED-CAPACITOR VOLTAGE CONVERTERS WITH REGULATORS

SLVS033F – FEBRUARY 1990 – REVISED NOVEMBER 2004

APPLICATION INFORMATION

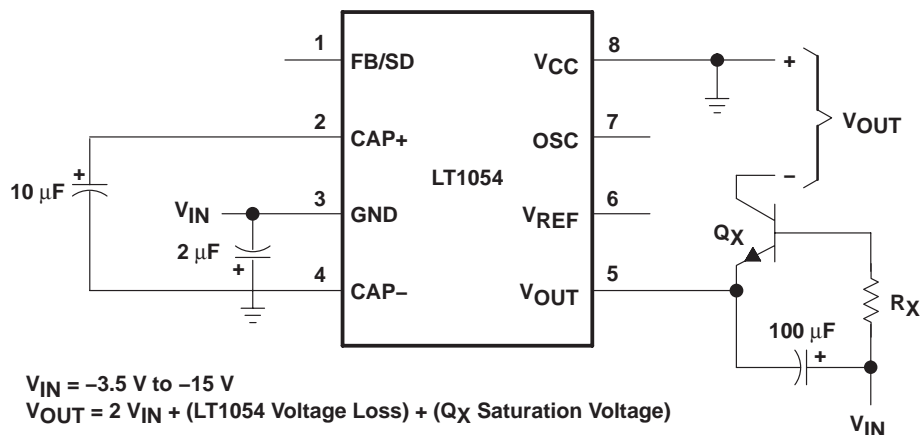

Pin numbers shown are for the P package.

Figure 21. Negative-Voltage Doubler

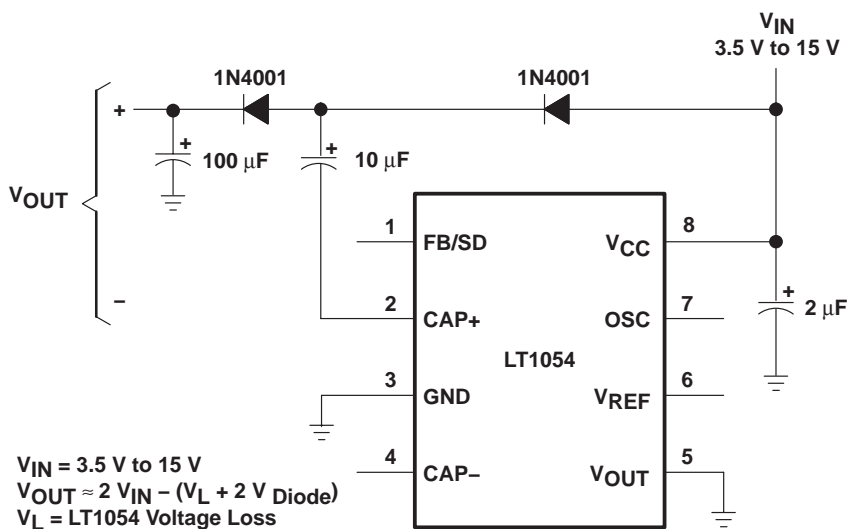

Pin numbers shown are for the P package.

Figure 22. Positive-Voltage Doubler

APPLICATION INFORMATION

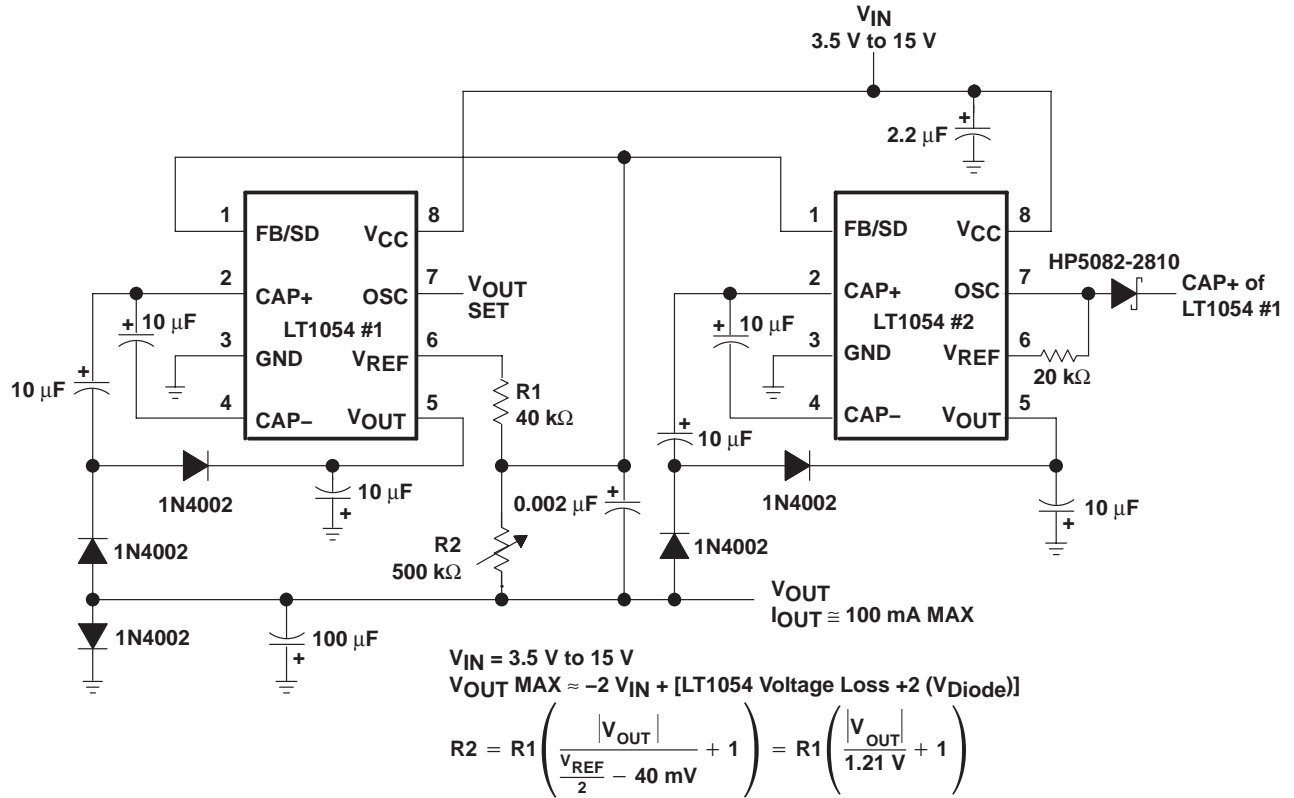

Pin numbers shown are for the P package.

Figure 23. 100-mA Regulating Negative Doubler

APPLICATION INFORMATION

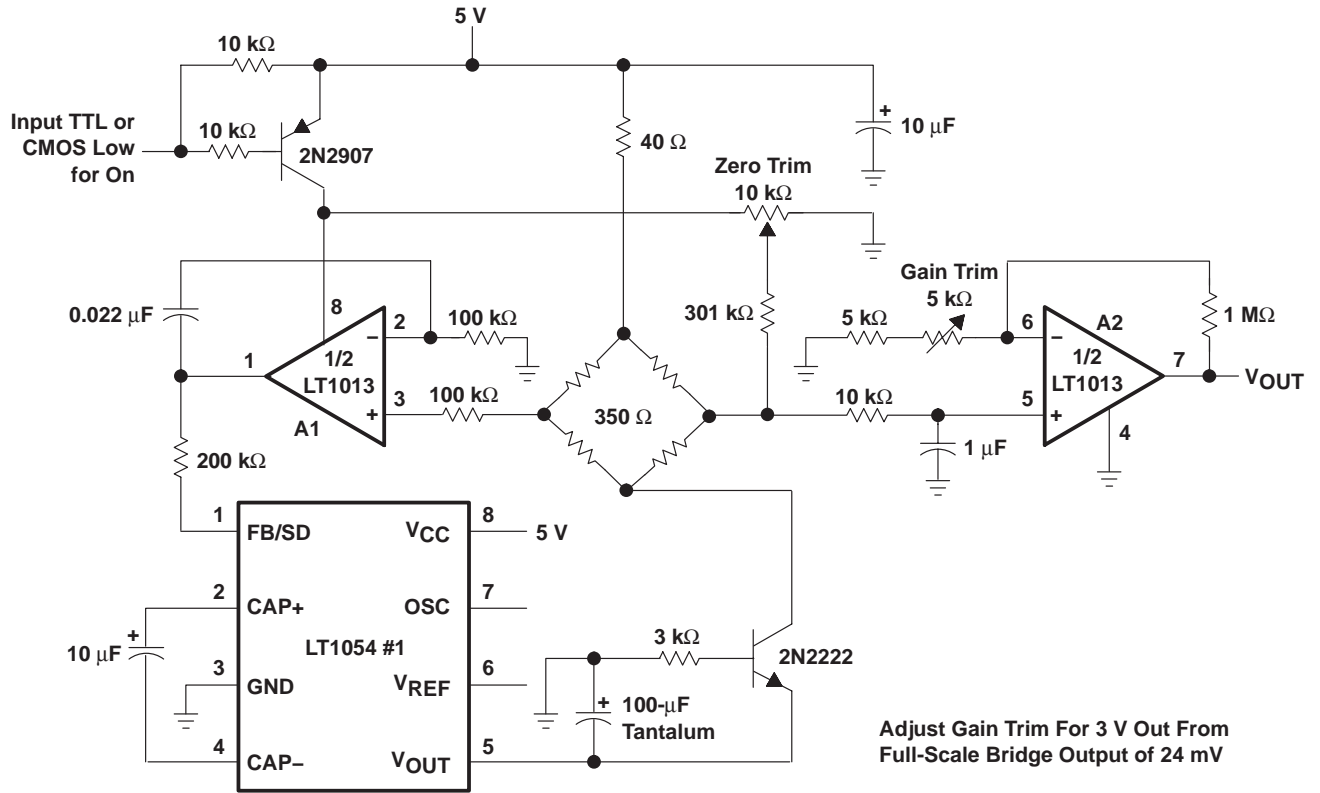

Pin numbers shown are for the P package.

Figure 26. Strain-Gage Bridge Signal Conditioner

APPLICATION INFORMATION

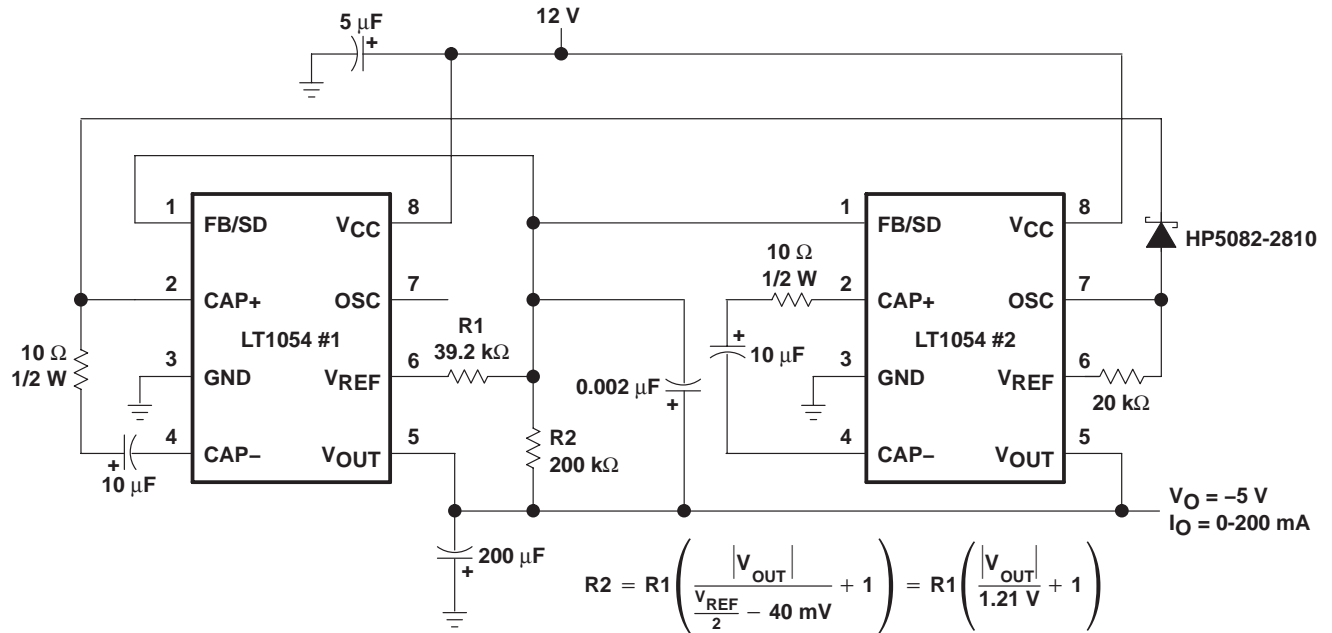

Pin numbers shown are for the P package.

Figure 28. Regulating 200-mA +12-V to -5-V Converter

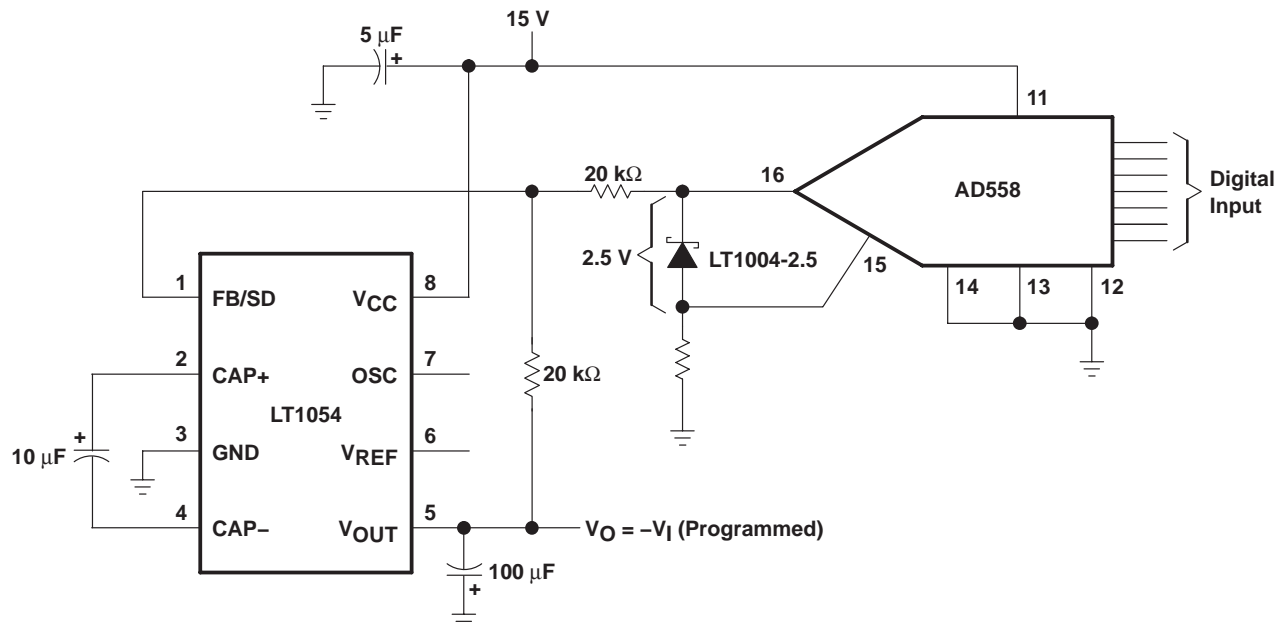

Pin numbers shown are for the P package.

Figure 29. Digitally Programmable Negative Supply

LT1054 SWITCHED-CAPACITOR VOLTAGE CONVERTERS WITH REGULATORS

SLVS033F – FEBRUARY 1990 – REVISED NOVEMBER 2004

APPLICATION INFORMATION

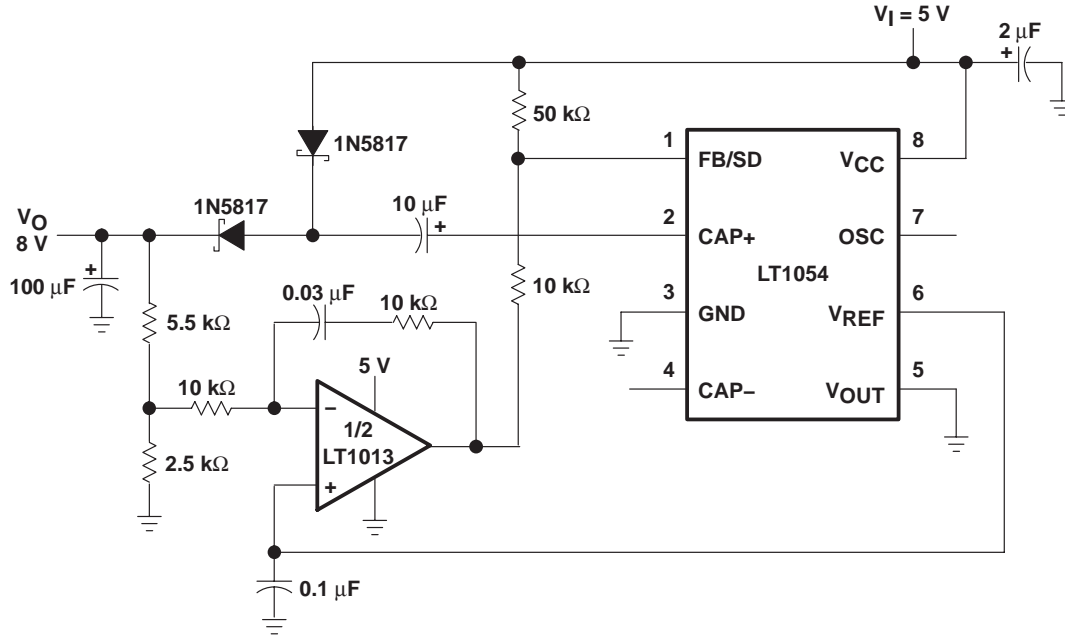

Pin numbers shown are for the P package.

Figure 30. Positive Doubler With Regulation (5-V to 8-V Converter)

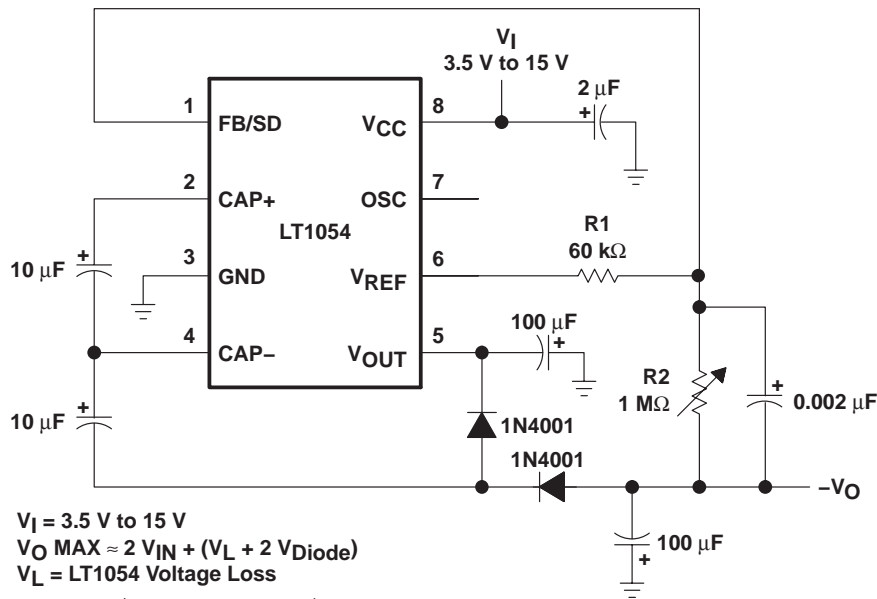

$V_1 = 3.5 \text{ V to } 15 \text{ V}$
 $V_O \text{ MAX} \approx 2 V_{IN} + (V_L + 2 V_{Diode})$
 $V_L = \text{LT1054 Voltage Loss}$

$$R_2 = R_1 \left(\frac{|V_{OUT}|}{\frac{V_{REF}}{2} - 40 \text{ mV}} + 1 \right) = R_1 \left(\frac{|V_{OUT}|}{1.21 \text{ V} + 1} + 1 \right)$$

Pin numbers shown are for the P package.

Figure 31. Negative Doubler With Regulator

PACKAGING INFORMATION

Orderable Device	Status ⁽¹⁾	Package Type	Package Drawing	Pins	Package Qty	Eco Plan ⁽²⁾	Lead/Ball Finish	MSL Peak Temp ⁽³⁾
LT1054CDW	ACTIVE	SOIC	DW	16	40	Green (RoHS & no Sb/Br)	CU NIPDAU	Level-1-260C-UNLIM
LT1054CDWE4	ACTIVE	SOIC	DW	16	40	Green (RoHS & no Sb/Br)	CU NIPDAU	Level-1-260C-UNLIM
LT1054CDWG4	ACTIVE	SOIC	DW	16	40	Green (RoHS & no Sb/Br)	CU NIPDAU	Level-1-260C-UNLIM
LT1054CDWR	ACTIVE	SOIC	DW	16	2000	Green (RoHS & no Sb/Br)	CU NIPDAU	Level-1-260C-UNLIM
LT1054CDWRE4	ACTIVE	SOIC	DW	16	2000	Green (RoHS & no Sb/Br)	CU NIPDAU	Level-1-260C-UNLIM
LT1054CDWRG4	ACTIVE	SOIC	DW	16	2000	Green (RoHS & no Sb/Br)	CU NIPDAU	Level-1-260C-UNLIM
LT1054CP	ACTIVE	PDIP	P	8	50	Pb-Free (RoHS)	CU NIPDAU	N / A for Pkg Type
LT1054CPE4	ACTIVE	PDIP	P	8	50	Pb-Free (RoHS)	CU NIPDAU	N / A for Pkg Type
LT1054IDW	ACTIVE	SOIC	DW	16	40	Green (RoHS & no Sb/Br)	CU NIPDAU	Level-1-260C-UNLIM
LT1054IDWG4	ACTIVE	SOIC	DW	16	40	Green (RoHS & no Sb/Br)	CU NIPDAU	Level-1-260C-UNLIM
LT1054IDWR	ACTIVE	SOIC	DW	16	2000	Green (RoHS & no Sb/Br)	CU NIPDAU	Level-1-260C-UNLIM
LT1054IDWRG4	ACTIVE	SOIC	DW	16	2000	Green (RoHS & no Sb/Br)	CU NIPDAU	Level-1-260C-UNLIM
LT1054IP	ACTIVE	PDIP	P	8	50	Pb-Free (RoHS)	CU NIPDAU	N / A for Pkg Type
LT1054IPE4	ACTIVE	PDIP	P	8	50	Pb-Free (RoHS)	CU NIPDAU	N / A for Pkg Type
LT1054Y	OBSOLETE	DIESALE	Y	0		TBD	Call TI	Call TI

⁽¹⁾ The marketing status values are defined as follows:

ACTIVE: Product device recommended for new designs.

LIFEBUY: TI has announced that the device will be discontinued, and a lifetime-buy period is in effect.

NRND: Not recommended for new designs. Device is in production to support existing customers, but TI does not recommend using this part in a new design.

PREVIEW: Device has been announced but is not in production. Samples may or may not be available.

OBSOLETE: TI has discontinued the production of the device.

⁽²⁾ Eco Plan - The planned eco-friendly classification: Pb-Free (RoHS), Pb-Free (RoHS Exempt), or Green (RoHS & no Sb/Br) - please check <http://www.ti.com/productcontent> for the latest availability information and additional product content details.

TBD: The Pb-Free/Green conversion plan has not been defined.

Pb-Free (RoHS): TI's terms "Lead-Free" or "Pb-Free" mean semiconductor products that are compatible with the current RoHS requirements for all 6 substances, including the requirement that lead not exceed 0.1% by weight in homogeneous materials. Where designed to be soldered at high temperatures, TI Pb-Free products are suitable for use in specified lead-free processes.

Pb-Free (RoHS Exempt): This component has a RoHS exemption for either 1) lead-based flip-chip solder bumps used between the die and package, or 2) lead-based die adhesive used between the die and leadframe. The component is otherwise considered Pb-Free (RoHS compatible) as defined above.

Green (RoHS & no Sb/Br): TI defines "Green" to mean Pb-Free (RoHS compatible), and free of Bromine (Br) and Antimony (Sb) based flame retardants (Br or Sb do not exceed 0.1% by weight in homogeneous material)

⁽³⁾ MSL, Peak Temp. -- The Moisture Sensitivity Level rating according to the JEDEC industry standard classifications, and peak solder temperature.

Important Information and Disclaimer:The information provided on this page represents TI's knowledge and belief as of the date that it is provided. TI bases its knowledge and belief on information provided by third parties, and makes no representation or warranty as to the accuracy of such information. Efforts are underway to better integrate information from third parties. TI has taken and continues to take reasonable steps to provide representative and accurate information but may not have conducted destructive testing or chemical analysis on incoming materials and chemicals. TI and TI suppliers consider certain information to be proprietary, and thus CAS numbers and other limited information may not be available for release.

In no event shall TI's liability arising out of such information exceed the total purchase price of the TI part(s) at issue in this document sold by TI to Customer on an annual basis.

TAPE AND REEL INFORMATION

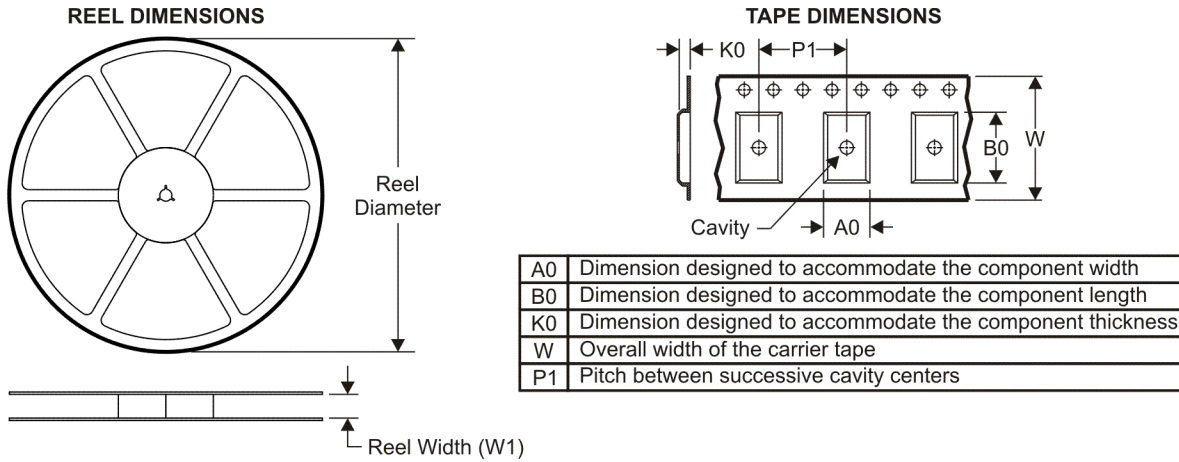

QUADRANT ASSIGNMENTS FOR PIN 1 ORIENTATION IN TAPE

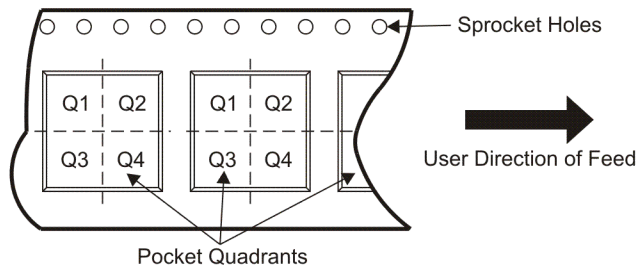

*All dimensions are nominal

Device	Package Type	Package Drawing	Pins	SPQ	Reel Diameter (mm)	Reel Width W1 (mm)	A0 (mm)	B0 (mm)	K0 (mm)	P1 (mm)	W (mm)	Pin1 Quadrant
LT1054CDWR	SOIC	DW	16	2000	330.0	16.4	10.75	10.7	2.7	12.0	16.0	Q1
LT1054IDWR	SOIC	DW	16	2000	330.0	16.4	10.75	10.7	2.7	12.0	16.0	Q1

TAPE AND REEL BOX DIMENSIONS

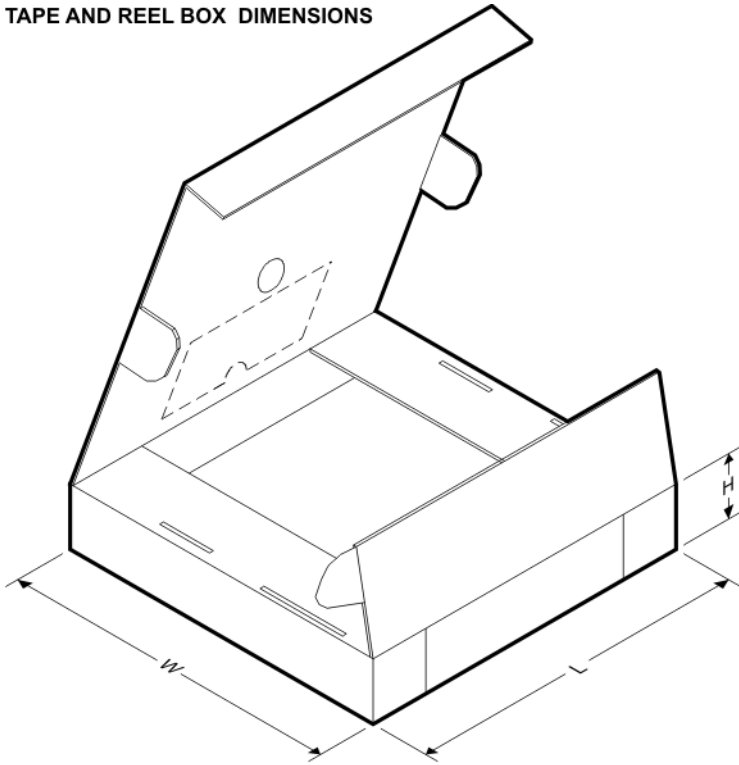

*All dimensions are nominal

Device	Package Type	Package Drawing	Pins	SPQ	Length (mm)	Width (mm)	Height (mm)
LT1054CDWR	SOIC	DW	16	2000	346.0	346.0	33.0
LT1054IDWR	SOIC	DW	16	2000	346.0	346.0	33.0

DW (R-PDSO-G16)

PLASTIC SMALL-OUTLINE PACKAGE

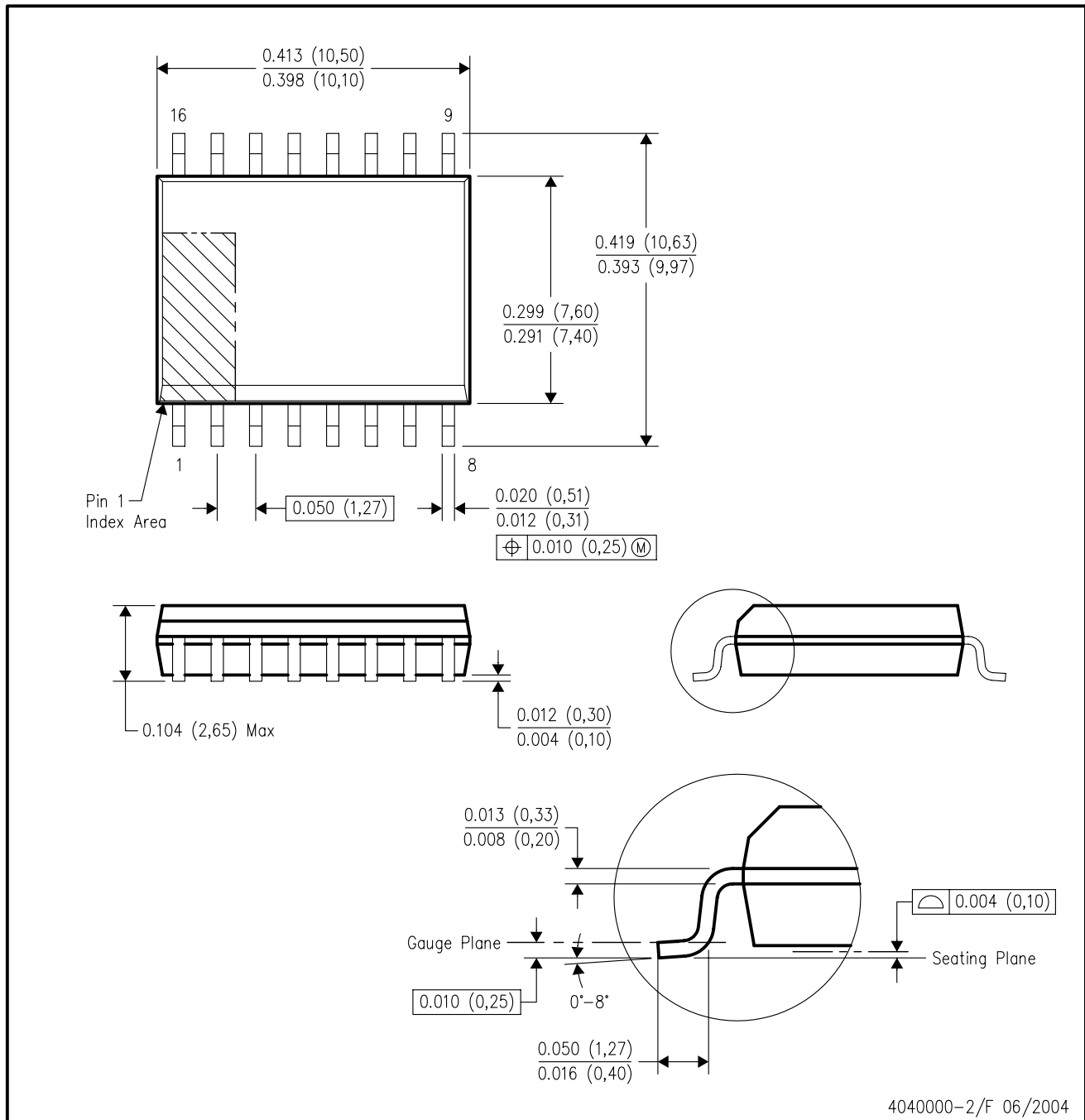

4040000-2/F 06/2004

- NOTES:
- A. All linear dimensions are in inches (millimeters).
 - B. This drawing is subject to change without notice.
 - C. Body dimensions do not include mold flash or protrusion not to exceed 0.006 (0,15).
 - D. Falls within JEDEC MS-013 variation AA.

P (R-PDIP-T8)

PLASTIC DUAL-IN-LINE

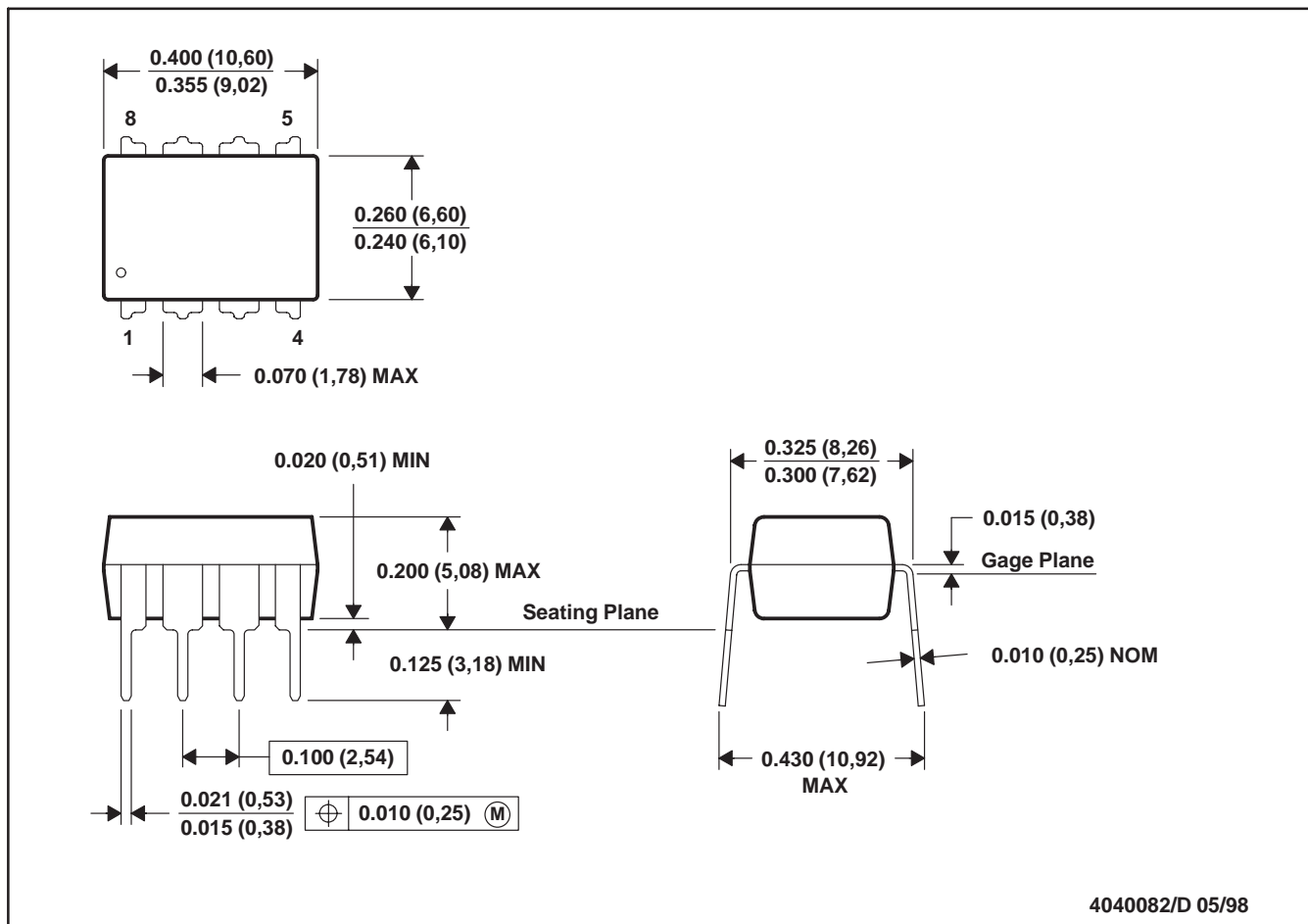

- NOTES: A. All linear dimensions are in inches (millimeters).
 B. This drawing is subject to change without notice.
 C. Falls within JEDEC MS-001

For the latest package information, go to http://www.ti.com/sc/docs/package/pkg_info.htm

IMPORTANT NOTICE

Texas Instruments Incorporated and its subsidiaries (TI) reserve the right to make corrections, modifications, enhancements, improvements, and other changes to its products and services at any time and to discontinue any product or service without notice. Customers should obtain the latest relevant information before placing orders and should verify that such information is current and complete. All products are sold subject to TI's terms and conditions of sale supplied at the time of order acknowledgment.

TI warrants performance of its hardware products to the specifications applicable at the time of sale in accordance with TI's standard warranty. Testing and other quality control techniques are used to the extent TI deems necessary to support this warranty. Except where mandated by government requirements, testing of all parameters of each product is not necessarily performed.

TI assumes no liability for applications assistance or customer product design. Customers are responsible for their products and applications using TI components. To minimize the risks associated with customer products and applications, customers should provide adequate design and operating safeguards.

TI does not warrant or represent that any license, either express or implied, is granted under any TI patent right, copyright, mask work right, or other TI intellectual property right relating to any combination, machine, or process in which TI products or services are used. Information published by TI regarding third-party products or services does not constitute a license from TI to use such products or services or a warranty or endorsement thereof. Use of such information may require a license from a third party under the patents or other intellectual property of the third party, or a license from TI under the patents or other intellectual property of TI.

Reproduction of TI information in TI data books or data sheets is permissible only if reproduction is without alteration and is accompanied by all associated warranties, conditions, limitations, and notices. Reproduction of this information with alteration is an unfair and deceptive business practice. TI is not responsible or liable for such altered documentation. Information of third parties may be subject to additional restrictions.

Resale of TI products or services with statements different from or beyond the parameters stated by TI for that product or service voids all express and any implied warranties for the associated TI product or service and is an unfair and deceptive business practice. TI is not responsible or liable for any such statements.

TI products are not authorized for use in safety-critical applications (such as life support) where a failure of the TI product would reasonably be expected to cause severe personal injury or death, unless officers of the parties have executed an agreement specifically governing such use. Buyers represent that they have all necessary expertise in the safety and regulatory ramifications of their applications, and acknowledge and agree that they are solely responsible for all legal, regulatory and safety-related requirements concerning their products and any use of TI products in such safety-critical applications, notwithstanding any applications-related information or support that may be provided by TI. Further, Buyers must fully indemnify TI and its representatives against any damages arising out of the use of TI products in such safety-critical applications.

TI products are neither designed nor intended for use in military/aerospace applications or environments unless the TI products are specifically designated by TI as military-grade or "enhanced plastic." Only products designated by TI as military-grade meet military specifications. Buyers acknowledge and agree that any such use of TI products which TI has not designated as military-grade is solely at the Buyer's risk, and that they are solely responsible for compliance with all legal and regulatory requirements in connection with such use.

TI products are neither designed nor intended for use in automotive applications or environments unless the specific TI products are designated by TI as compliant with ISO/TS 16949 requirements. Buyers acknowledge and agree that, if they use any non-designated products in automotive applications, TI will not be responsible for any failure to meet such requirements.

Following are URLs where you can obtain information on other Texas Instruments products and application solutions:

Products

Amplifiers	amplifier.ti.com
Data Converters	dataconverter.ti.com
DSP	dsp.ti.com
Clocks and Timers	www.ti.com/clocks
Interface	interface.ti.com
Logic	logic.ti.com
Power Mgmt	power.ti.com
Microcontrollers	microcontroller.ti.com
RFID	www.ti-rfid.com
RF/IF and ZigBee® Solutions	www.ti.com/lprf

Applications

Audio	www.ti.com/audio
Automotive	www.ti.com/automotive
Broadband	www.ti.com/broadband
Digital Control	www.ti.com/digitalcontrol
Medical	www.ti.com/medical
Military	www.ti.com/military
Optical Networking	www.ti.com/opticalnetwork
Security	www.ti.com/security
Telephony	www.ti.com/telephony
Video & Imaging	www.ti.com/video
Wireless	www.ti.com/wireless

Mailing Address: Texas Instruments, Post Office Box 655303, Dallas, Texas 75265
Copyright © 2008, Texas Instruments Incorporated