

LT1014, LT1014A, LT1014D QUAD PRECISION OPERATIONAL AMPLIFIERS

SLOS039D – JULY 1989 – REVISED AUGUST 2009

- **Single-Supply Operation:**
Input Voltage Range Extends to Ground, and Output Swings to Ground While Sinking Current
- **Input Offset Voltage 300 μV Max at 25°C for LT1014**
- **Offset Voltage Temperature Coefficient 2.5 $\mu\text{V}/^\circ\text{C}$ Max for LT1014**
- **Input Offset Current 1.5 nA Max at 25°C for LT1014**
- **High Gain 1.2 $\text{V}/\mu\text{V}$ Min ($R_L = 2 \text{ k}\Omega$), 0.5 $\text{V}/\mu\text{V}$ Min ($R_L = 600 \Omega$) for LT1014**
- **Low Supply Current 2.2 mA Max at 25°C for LT 1014**
- **Low Peak-to-Peak Noise Voltage 0.55 μV Typ**
- **Low Current Noise 0.07 $\text{pA}/\sqrt{\text{Hz}}$ Typ**

description

The LT1014, LT1014A, and LT1014D are quad precision operational amplifiers with 14-pin industry-standard configuration. They feature low offset-voltage temperature coefficient, high gain, low supply current, and low noise.

The LT1014, LT1014A, and LT1014D can be operated with both dual $\pm 15\text{-V}$ and single 5-V power supplies. The common-mode input voltage range includes ground, and the output voltage can also swing to within a few millivolts of ground. Crossover distortion is eliminated.

The LT1014C and LT1014D are characterized for operation from 0°C to 70°C. The LT1014I and LT1014DI are characterized for operation from -40°C to 105°C. The LT1014M, LT1014AM and LT1014DM are characterized for operation over the full military temperature range of -55°C to 125°C.

**DW PACKAGE
(TOP VIEW)**

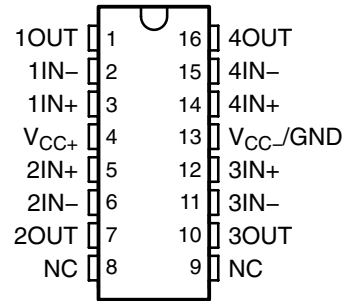

**J OR N PACKAGE
(TOP VIEW)**

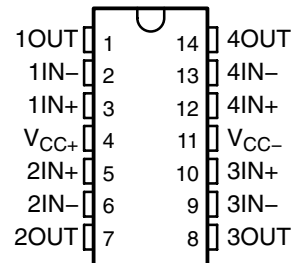

**FK PACKAGE
(TOP VIEW)**

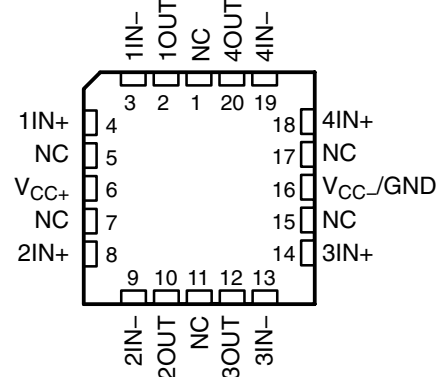

NC – No internal connection



Please be aware that an important notice concerning availability, standard warranty, and use in critical applications of Texas Instruments semiconductor products and disclaimers thereto appears at the end of this data sheet.

PRODUCTION DATA information is current as of publication date. Products conform to specifications per the terms of Texas Instruments standard warranty. Production processing does not necessarily include testing of all parameters.

**TEXAS
INSTRUMENTS**

POST OFFICE BOX 655303 • DALLAS, TEXAS 75265

Copyright © 2009, Texas Instruments Incorporated

LT1014, LT1014A, LT1014D QUAD PRECISION OPERATIONAL AMPLIFIERS

SLOS039D – JULY 1989 – REVISED AUGUST 2009

AVAILABLE OPTIONS[†]

T _A	V _{IO} max AT 25°C	PACKAGED DEVICES [‡]			
		SMALL OUTLINE (DW) [§]	CHIP CARRIER (FK)	CERAMIC DIP (J)	PLASTIC DIP (N)
0°C to 70°C	300 μV 800 μV	— LT1014DDW	— —	— —	LT1014CN LT1014DN
–40°C to 105°C	300 μV 800 μV	— LT1014DIDW	— —	— —	LT1014IN LT1014DIN
–55°C to 125°C	180 μV 300 μV 800 μV	— — LT1014DMDW	LT1014AMFK LT1014MFK —	LT1014AMJ LT1014MJ —	— LT1014MN LT1014DMN

[†] For the most current package and ordering information, see the Package Option Addendum at the end of this document, or see the TI web site at www.ti.com.

[‡] Package drawings, thermal data, and symbolization are available at www.ti.com/packaging.

[§] The DW package is available taped and reeled. Add the suffix R to the device type (e.g., LT1014DDWR).



POST OFFICE BOX 655303 • DALLAS, TEXAS 75265

LT1014, LT1014A, LT1014D QUAD PRECISION OPERATIONAL AMPLIFIERS

SLOS039D – JULY 1989 – REVISED AUGUST 2009

schematic (each amplifier)

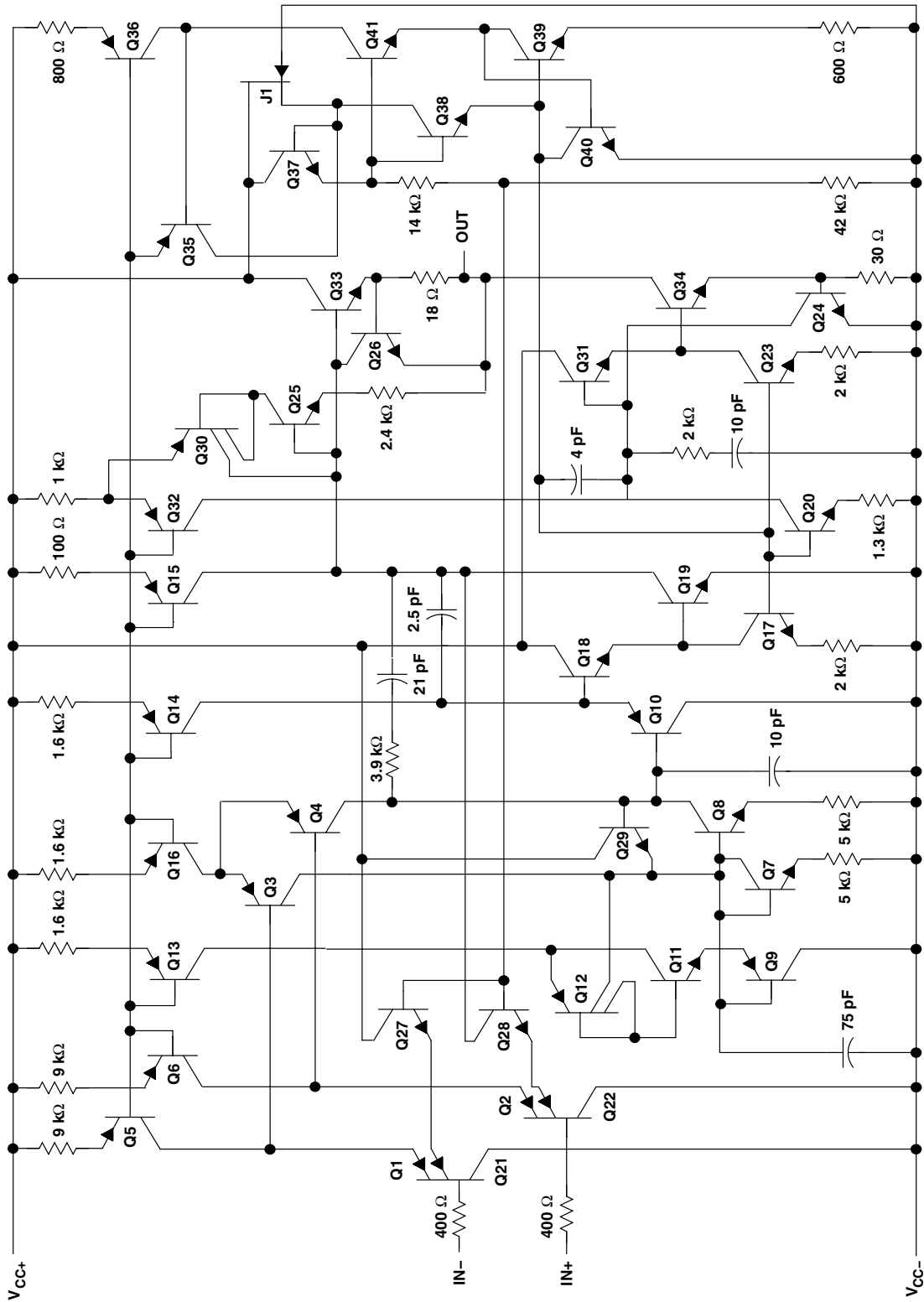

Component values are nominal.

LT1014, LT1014A, LT1014D QUAD PRECISION OPERATIONAL AMPLIFIERS

SLOS039D – JULY 1989 – REVISED AUGUST 2009

absolute maximum ratings over operating free-air temperature range (unless otherwise noted)†

Supply voltage (see Note 1): V_{CC+}	22 V
V_{CC-}	-22 V
Differential input voltage (see Note 2)	± 30 V
Input voltage range, V_I (any input) (see Note 1)	$V_{CC-} - 5$ V to V_{CC+}
Duration of short-circuit current at (or below) $T_A = 25^\circ\text{C}$ (see Note 3)	Unlimited
Continuous total power dissipation	See Dissipation Rating Table
Operating free-air temperature range, T_A : LT1014C, LT1014D	-0°C to 70°C
LT1014I, LT1014DI	-40°C to 105°C
LT1014M, LT1014AM, LT1014DM	-55°C to 125°C
Case temperature for 60 seconds: FK package	260°C
Storage temperature range, T_{stg}	-65°C to 150°C

† Stresses beyond those listed under “absolute maximum ratings” may cause permanent damage to the device. These are stress ratings only, and functional operation of the device at these or any other conditions beyond those indicated under “recommended operating conditions” is not implied. Exposure to absolute-maximum-rated conditions for extended periods may affect device reliability.

- NOTES: 1. All voltage values, except differential voltages, are with respect to the midpoint between V_{CC+} and V_{CC-} .
 2. Differential voltages are at the noninverting input with respect to the inverting input.
 3. The output may be shorted to either supply.

DISSIPATION RATING TABLE

PACKAGE	$T_A \leq 25^\circ\text{C}$ POWER RATING	DERATING FACTOR ABOVE $T_A = 25^\circ\text{C}$	$T_A = 70^\circ\text{C}$ POWER RATING	$T_A = 105^\circ\text{C}$ POWER RATING	$T_A = 125^\circ\text{C}$ POWER RATING
DW	1025 mW	8.2 mW/ $^\circ\text{C}$	656 mW	369 mW	205 mW
FK	1375 mW	11.0 mW/ $^\circ\text{C}$	880 mW	495 mW	275 mW
J	1375 mW	11.0 mW/ $^\circ\text{C}$	880 mW	495 mW	275 mW
N	1150 mW	9.2 mW/ $^\circ\text{C}$	736 mW	414 mW	230 mW



LT1014, LT1014A, LT1014D QUAD PRECISION OPERATIONAL AMPLIFIERS

SLOS039D – JULY 1989 – REVISED AUGUST 2009

electrical characteristics at specified free-air temperature, $V_{CC\pm} = \pm 15\text{ V}$, $V_{IC} = 0$ (unless otherwise noted)

PARAMETER	TEST CONDITIONS	T_A †	LT1014C			LT1014D			UNIT
			MIN	TYP‡	MAX	MIN	TYP‡	MAX	
V_{IO} Input offset voltage	$R_S = 50\ \Omega$	25°C	60	300	200	800	μV		
		Full range	550			1000			
$\alpha_{V_{IO}}$ Temperature coefficient of input offset voltage		Full range	0.4	2.5	0.7	5	$\mu\text{V}/^\circ\text{C}$		
Long-term drift of input offset voltage		25°C	0.5			0.5	$\mu\text{V}/\text{mo}$		
I_{IO} Input offset current		25°C	0.15	1.5	0.15	1.5	nA		
		Full range	2.8			2.8			
I_{IB} Input bias current		25°C	-12	-30	-12	-30	nA		
		Full range	-38			-38			
V_{ICR} Common-mode input voltage range		25°C	-15 to 13.5	-15.3 to 13.8	-15 to 13.5	-15.3 to 13.8	V		
		Full range	-15 to 13			-15 to 13			
V_{OM} Maximum peak output voltage swing	$R_L = 2\ \text{k}\Omega$	25°C	± 12.5	± 14	± 12.5	± 14	V		
		Full range	± 12			± 12			
A_{VD} Large-signal differential voltage amplification	$V_O = \pm 10\ \text{V}$, $R_L = 600\ \Omega$	25°C	0.5	2	0.5	2	$\text{V}/\mu\text{V}$		
	$V_O = \pm 10\ \text{V}$, $R_L = 2\ \text{k}\Omega$	25°C	1.2	8	1.2	8			
		Full range	0.7			0.7			
CMRR Common-mode rejection ratio	$V_{IC} = -15\ \text{V}$ to $13.5\ \text{V}$	25°C	97	117	97	117	dB		
	$V_{IC} = -15\ \text{V}$ to $13\ \text{V}$	Full range	94			94			
k_{SVR} Supply-voltage rejection ratio ($\Delta V_{CC}/\Delta V_{IO}$)	$V_{CC\pm} = \pm 2\ \text{V}$ to $\pm 18\ \text{V}$	25°C	100	117	100	117	dB		
		Full range	97			97			
Channel separation	$V_O = \pm 10\ \text{V}$, $R_L = 2\ \text{k}\Omega$	25°C	120	137	120	137	dB		
r_{id} Differential input resistance		25°C	70	300	70	300	$\text{M}\Omega$		
r_{ic} Common-mode input resistance		25°C	4			4	$\text{G}\Omega$		
I_{CC} Supply current per amplifier		25°C	0.35	0.55	0.35	0.55	mA		
		Full range	0.6			0.6			

† Full range is 0°C to 70°C.

‡ All typical values are at $T_A = 25^\circ\text{C}$.



LT1014, LT1014A, LT1014D QUAD PRECISION OPERATIONAL AMPLIFIERS

SLOS039D – JULY 1989 – REVISED AUGUST 2009

electrical characteristics at specified free-air temperature, $V_{CC\pm} = 5\text{ V}$, $V_{CC-} = 0$, $V_O = 1.4\text{ V}$, $V_{IC} = 0$ (unless otherwise noted)

PARAMETER	TEST CONDITIONS	T_A^\dagger	LT1014C			LT1014D			UNIT
			MIN	TYP	MAX	MIN	TYP	MAX	
V_{IO} Input offset voltage	$R_S = 50\ \Omega$	25°C	90	450		250	950	μV	
		Full range			570		1200		
I_{IO} Input offset current		25°C	0.2	2		0.2	2	nA	
		Full range			6		6		
I_{IB} Input bias current		25°C	-15	-50		-15	-50	nA	
		Full range			-90		-90		
V_{ICR} Common-mode input voltage range		25°C	0 to 3.5	-0.3 to 3.8		0 to 3.5	-0.3 to 3.8	V	
		Full range	0 to 3			0 to 3			
V_{OM} Maximum peak output voltage swing	Output low, No load	25°C	15	25		15	25	mV	
	Output low, $R_L = 600\ \Omega$ to GND	25°C	5	10		5	10		
		Full range			13		13		
	Output low, $I_{\text{sink}} = 1\text{ mA}$	25°C	220	350		220	350	V	
	Output high, No load	25°C	4	4.4		4	4.4		
	Output high, $R_L = 600\ \Omega$ to GND	25°C	3.4	4		3.4	4		
Full range				3.2		3.2			
A_{VD} Large-signal differential voltage amplification	$V_O = 5\text{ mV}$ to 4 V, $R_L = 500\ \Omega$	25°C	1			1	$\text{V}/\mu\text{V}$		
I_{CC} Supply current per amplifier		25°C	0.3	0.5		0.3	0.5	mA	
		Full range			0.55		0.55		

† Full range is 0°C to 70°C.

operating characteristics, $V_{CC\pm} = \pm 15\text{ V}$, $V_{IC} = 0$, $T_A = 25^\circ\text{C}$

PARAMETER	TEST CONDITIONS	MIN	TYP	MAX	UNIT
SR Slew rate		0.2	0.4		$\text{V}/\mu\text{s}$
V_n Equivalent input noise voltage	$f = 10\text{ Hz}$		24		$\text{nV}/\sqrt{\text{Hz}}$
	$f = 1\text{ kHz}$		22		
$V_{N(PP)}$ Peak-to-peak equivalent input noise voltage	$f = 0.1\text{ Hz}$ to 10 Hz		0.55		μV
I_n Equivalent input noise current	$f = 10\text{ Hz}$		0.07		$\text{pA}/\sqrt{\text{Hz}}$



LT1014, LT1014A, LT1014D QUAD PRECISION OPERATIONAL AMPLIFIERS

SLOS039D – JULY 1989 – REVISED AUGUST 2009

electrical characteristics at specified free-air temperature, $V_{CC\pm} = \pm 15\text{ V}$, $V_{IC} = 0$ (unless otherwise noted)

PARAMETER	TEST CONDITIONS	T_A^\dagger	LT1014I		LT1014DI		UNIT
			MIN	TYP‡	MAX	MIN	
V_{IO} Input offset voltage	$R_S = 50\ \Omega$	25°C	60	300	200	800	μV
		Full range	550		1000		
$\alpha_{V_{IO}}$ Temperature coefficient of input offset voltage		Full range	0.4	2.5	0.7	5	$\mu\text{V}/^\circ\text{C}$
Long-term drift of input offset voltage		25°C	0.5		0.5		$\mu\text{V}/\text{mo}$
I_{IO} Input offset current		25°C	0.15	1.5	0.15	1.5	nA
		Full range	2.8		2.8		
I_{IB} Input bias current		25°C	-12	-30	-12	-30	nA
		Full range	-38		-38		
V_{ICR} Common-mode input voltage range		25°C	-15 to 13.5	-15.3 to 13.8	-15 to 13.5	-15.3 to 13.8	V
		Full range	-15 to 13		-15 to 13		
V_{OM} Maximum peak output voltage swing	$R_L = 2\ \text{k}\Omega$	25°C	± 12.5	± 14	± 12.5	± 14	V
		Full range	± 12		± 12		
A_{VD} Large-signal differential voltage amplification	$V_O = \pm 10\ \text{V}$, $R_L = 600\ \Omega$	25°C	0.5	2	0.5	2	$\text{V}/\mu\text{V}$
	$V_O = \pm 10\ \text{V}$, $R_L = 2\ \text{k}\Omega$	25°C	1.2	8	1.2	8	
		Full range	0.7		0.7		
CMRR Common-mode rejection ratio	$V_{IC} = -15\ \text{V}$ to $13.5\ \text{V}$	25°C	97	117	97	117	dB
		Full range	94		94		
k_{SVR} Supply-voltage rejection ratio ($\Delta V_{CC}/\Delta V_{IO}$)	$V_{CC\pm} = \pm 2\ \text{V}$ to $\pm 18\ \text{V}$	25°C	100	117	100	117	dB
		Full range	97		97		
Channel separation	$V_O = \pm 10\ \text{V}$, $R_L = 2\ \text{k}\Omega$	25°C	120	137	120	137	dB
r_{id} Differential input resistance		25°C	70	300	70	300	$\text{M}\Omega$
r_{ic} Common-mode input resistance		25°C	4		4		$\text{G}\Omega$
I_{CC} Supply current per amplifier		25°C	0.35	0.55	0.35	0.55	mA
		Full range	0.6		0.6		

† Full range is -40°C to 105°C .

‡ All typical values are at $T_A = 25^\circ\text{C}$.



LT1014, LT1014A, LT1014D QUAD PRECISION OPERATIONAL AMPLIFIERS

SLOS039D – JULY 1989 – REVISED AUGUST 2009

electrical characteristics at specified free-air temperature, $V_{CC+} = 5\text{ V}$, $V_{CC-} = 0$, $V_O = 1.4\text{ V}$, $V_{IC} = 0$ (unless otherwise noted)

PARAMETER	TEST CONDITIONS	T_A †	LT1014I			LT1014DI			UNIT
			MIN	TYP	MAX	MIN	TYP	MAX	
V_{IO} Input offset voltage	$R_S = 50\ \Omega$	25°C	90	450		250	950	μV	
		Full range			570		1200		
I_{IO} Input offset current		25°C	0.2	2		0.2	2	nA	
		Full range			6		6		
I_{IB} Input bias current		25°C	-15	-50		-15	-50	nA	
		Full range			-90		-90		
V_{ICR} Common-mode input voltage range		25°C	0 to 3.5	-0.3 to 3.8		0 to 3.5	-0.3 to 3.8	V	
		Full range	0 to 3			0 to 3			
V_{OM} Maximum peak output voltage swing	Output low, No load	25°C	15	25		15	25	mV	
	Output low, $R_L = 600\ \Omega$ to GND	25°C	5	10		5	10		
		Full range			13		13		
	Output low, $I_{sink} = 1\text{ mA}$	25°C	220	350		220	350	V	
	Output high, No load	25°C	4	4.4		4	4.4		
	Output high, $R_L = 600\ \Omega$ to GND	25°C	3.4	4		3.4	4		
Full range				3.2		3.2			
A_{VD} Large-signal differential voltage amplification	$V_O = 5\text{ mV}$ to 4 V, $R_L = 500\ \Omega$	25°C	1			1	$\text{V}/\mu\text{V}$		
I_{CC} Supply current per amplifier		25°C	0.3	0.5		0.3	0.5	mA	
		Full range			0.55		0.55		

† Full range is -40°C to 105°C.

operating characteristics, $V_{CC+} = \pm 15\text{ V}$, $V_{IC} = 0$, $T_A = 25^\circ\text{C}$

PARAMETER	TEST CONDITIONS	MIN	TYP	MAX	UNIT
SR Slew rate		0.2	0.4		$\text{V}/\mu\text{s}$
V_n Equivalent input noise voltage	$f = 10\text{ Hz}$		24		$\text{nV}/\sqrt{\text{Hz}}$
	$f = 1\text{ kHz}$		22		
$V_{N(PP)}$ Peak-to-peak equivalent input noise voltage	$f = 0.1\text{ Hz}$ to 10 Hz		0.55		μV
I_n Equivalent input noise current	$f = 10\text{ Hz}$		0.07		$\text{pA}/\sqrt{\text{Hz}}$



LT1014, LT1014A, LT1014D QUAD PRECISION OPERATIONAL AMPLIFIERS

SLOS039D – JULY 1989 – REVISED AUGUST 2009

electrical characteristics at specified free-air temperature, $V_{CC\pm} = \pm 15\text{ V}$, $V_{IC} = 0$ (unless otherwise noted)

PARAMETER	TEST CONDITIONS	T_A^\dagger	LT1014M			LT1014AM			LT1014DM			UNIT
			MIN	TYP ‡	MAX	MIN	TYP ‡	MAX	MIN	TYP ‡	MAX	
V_{IO} Input offset voltage	$R_S = 50\ \Omega$	25°C	60	300		60	180		200	800	μV	
		Full range			550		350			1000		
$\alpha_{V_{IO}}$ Temperature coefficient of input offset voltage		Full range	0.5	2.5		0.5	2		0.5	2.5	$\mu\text{V}/^\circ\text{C}$	
Long-term drift of input offset voltage		25°C	0.5			0.5			0.5		$\mu\text{V}/\text{mo}$	
I_{IO} Input offset current		25°C	0.15	1.5		0.15	0.8		0.15	1.5	nA	
		Full range			5		2.8			5		
I_{IB} Input bias current		25°C	-12	-30		-12	-20		-12	-30	nA	
		Full range			-45		-30			-45		
V_{ICR} Common-mode input voltage range		25°C	-15 to 13.5	-15.3 to 13.8		-15 to 13.5	-15.3 to 13.8		-15 to 13.5	-15.3 to 13.8	V	
		Full range	-14.9 to 13			-14.9 to 13			-14.9 to 13			
V_{OM} Maximum peak output voltage swing	$R_L = 2\ \text{k}\Omega$	25°C	± 12.5	± 14		± 13	± 14		± 12.5	± 14	V	
		Full range	± 11.5			± 12			± 11.5			
A_{VD} Large-signal differential voltage amplification	$V_O = \pm 10\ \text{V}$, $R_L = 600\ \Omega$	25°C	0.5	2		0.8	2.2		0.5	2	$\text{V}/\mu\text{V}$	
		25°C	$V_O = \pm 10\ \text{V}$, $R_L = 2\ \text{k}\Omega$	1.2	8		1.5	8		1.2		8
				Full range	0.25			0.4				0.25
CMRR Common-mode rejection ratio	$V_{IC} = -15\ \text{V}$ to 13.5 V	25°C	97	117		100	117		97	117	dB	
		Full range	94			96			94			
k_{SVR} Supply-voltage rejection ratio ($\Delta V_{CC}/\Delta V_{IO}$)	$V_{CC\pm} = \pm 2\ \text{V}$ to $\pm 18\ \text{V}$	25°C	100	117		103	117		100	117	dB	
		Full range	97			100			97			
Channel separation	$V_O = \pm 10\ \text{V}$, $R_L = 2\ \text{k}\Omega$	25°C	120	137		123	137		120	137	dB	
r_{id} Differential input resistance		25°C	70	300		100	300		70	300	$\text{M}\Omega$	
r_{ic} Common-mode input resistance		25°C	4			4			4		$\text{G}\Omega$	
I_{CC} Supply current per amplifier		25°C	0.35	0.55		0.35	0.50		0.35	0.55	mA	
		Full range			0.7		0.6			0.7		

† Full range is -55°C to 125°C .

‡ All typical values are at $T_A = 25^\circ\text{C}$.

LT1014, LT1014A, LT1014D QUAD PRECISION OPERATIONAL AMPLIFIERS

SLOS039D – JULY 1989 – REVISED AUGUST 2009

electrical characteristics at specified free-air temperature, $V_{CC+} = 5\text{ V}$, $V_{CC-} = 0$, $V_O = 1.4\text{ V}$, $V_{IC} = 0$ (unless otherwise noted)

PARAMETER	TEST CONDITIONS	T_A^\dagger	LT1014M			LT1014AM			LT1014DM			UNIT
			MIN	TYP	MAX	MIN	TYP	MAX	MIN	TYP	MAX	
V_{IO} Input offset voltage	$R_S = 50\Omega$	25°C	90	450		90	280		250	950	μV	
		Full range	400	1500		400	960		800	2000		
	$R_S = 50\Omega$, $V_{IC} = 0.1\text{ V}$	125°C	200	750		200	480		560	1200		
I_{IO} Input offset current		25°C	0.2	2		0.2	1.3		0.2	2	nA	
		Full range		10			7			10		
I_{IB} Input bias current		25°C	-15	-50		-15	-35		-15	-50	nA	
		Full range		-120			-90			-120		
V_{ICR} Common-mode input voltage range		25°C	0 to 3.5	-0.3 to 3.8		0 to 3.5	-0.3 to 3.8		0 to 3.5	-0.3 to 3.8	V	
		Full range	0.1 to 3			0.1 to 3			0.1 to 3			
V_{OM} Maximum peak output voltage swing	Output low, No load	25°C	15	25		15	25		15	25	mV	
	Output low, $R_L = 600\Omega$ to GND	25°C	5	10		5	10		5	10		
		Full range		18			15			18		
	Output low, $I_{sink} = 1\text{ mA}$	25°C	220	350		220	350		220	350	V	
	Output high, No load	25°C	4	4.4		4	4.4		4	4.4		
	Output high, $R_L = 600\Omega$ to GND	Full range	3.1			3.2			3.1			
A_{VD} Large-signal differential voltage amplification	$V_O = 5\text{ mV}$ to 4 V, $R_L = 500\Omega$	25°C		1			1			1	$\text{V}/\mu\text{V}$	
I_{CC} Supply current per amplifier		25°C	0.3	0.5		0.3	0.45		0.3	0.5	mA	
		Full range		0.65			0.55			0.65		

† Full range is -55°C to 125°C.

operating characteristics, $V_{CC\pm} = \pm 15\text{ V}$, $V_{IC} = 0$, $T_A = 25^\circ\text{C}$

PARAMETER	TEST CONDITIONS	MIN	TYP	MAX	UNIT
SR Slew rate		0.2	0.4		$\text{V}/\mu\text{s}$
V_n Equivalent input noise voltage	$f = 10\text{ Hz}$		24		$\text{nV}/\sqrt{\text{Hz}}$
	$f = 1\text{ kHz}$		22		
$V_{N(PP)}$ Peak-to-peak equivalent input noise voltage	$f = 0.1\text{ Hz}$ to 10 Hz		0.55		μV
I_n Equivalent input noise current	$f = 10\text{ Hz}$		0.07		$\text{pA}/\sqrt{\text{Hz}}$



TYPICAL CHARACTERISTICS

Table of Graphs

		FIGURE	
V_{IO}	Input offset voltage vs Balanced source resistance	1	
V_{IO}	Input offset voltage vs Free-air temperature	2	
ΔV_{IO}	Warm-Up Change in input offset voltage vs Elapsed time	3	
I_{IO}	Input offset current vs Free-air temperature	4	
I_{IB}	Input bias current vs Free-air temperature	5	
V_{IC}	Common-mode input voltage vs Input bias current	6	
A_{VD}	Differential voltage amplification	vs Load resistance	7, 8
		vs Frequency	9, 10
	Channel separation vs Frequency	11	
	Output saturation voltage vs Free-air temperature	12	
CMRR	Common-mode rejection ratio vs Frequency	13	
k_{SVR}	Supply-voltage rejection ratio vs Frequency	14	
I_{CC}	Supply current vs Free-air temperature	15	
I_{OS}	Short-circuit output current vs Elapsed time	16	
V_n	Equivalent input noise voltage vs Frequency	17	
I_n	Equivalent input noise current vs Frequency	17	
$V_{N(PP)}$	Peak-to-peak input noise voltage vs Time	18	
	Pulse response (small signal) vs Time	19, 21	
	Pulse response (large signal) vs Time	20, 22, 23	
	Phase shift vs Frequency	9	

LT1014, LT1014A, LT1014D QUAD PRECISION OPERATIONAL AMPLIFIERS

SLOS039D – JULY 1989 – REVISED AUGUST 2009

TYPICAL CHARACTERISTICS†

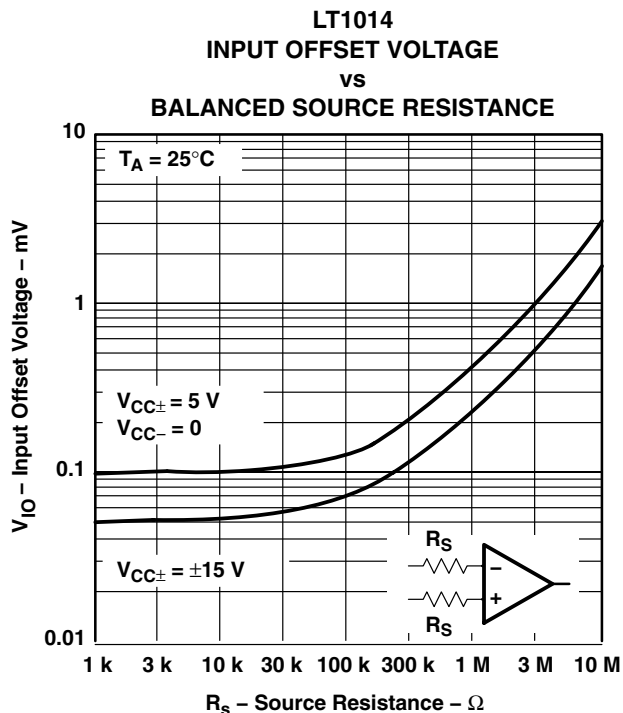

Figure 1

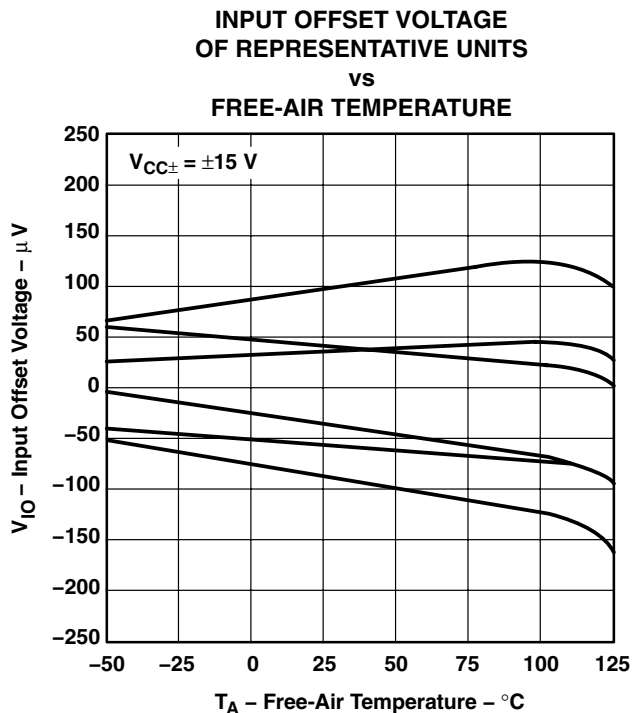

Figure 2

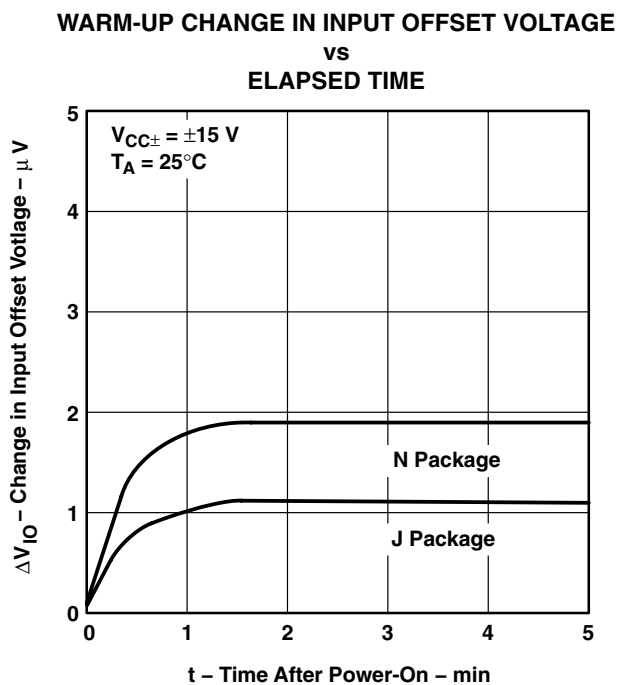

Figure 3

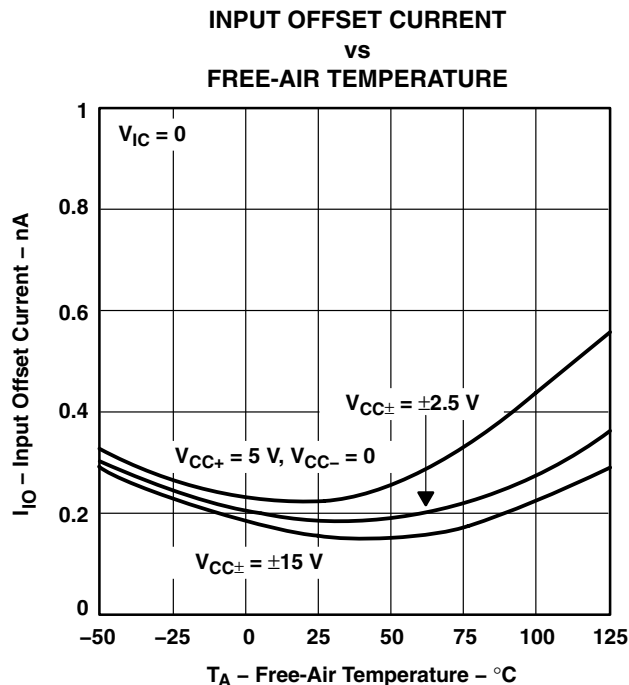
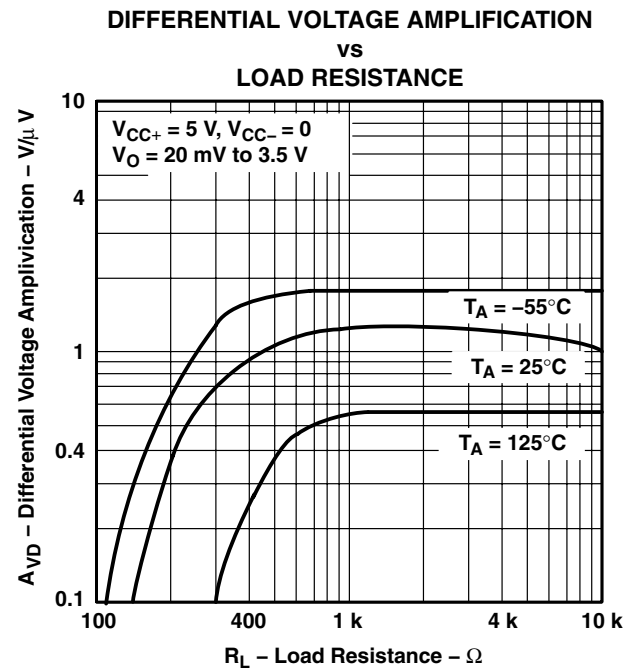
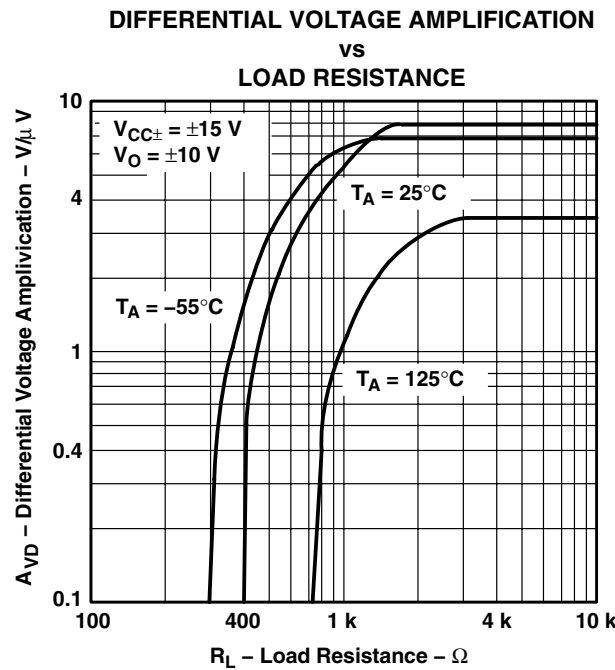
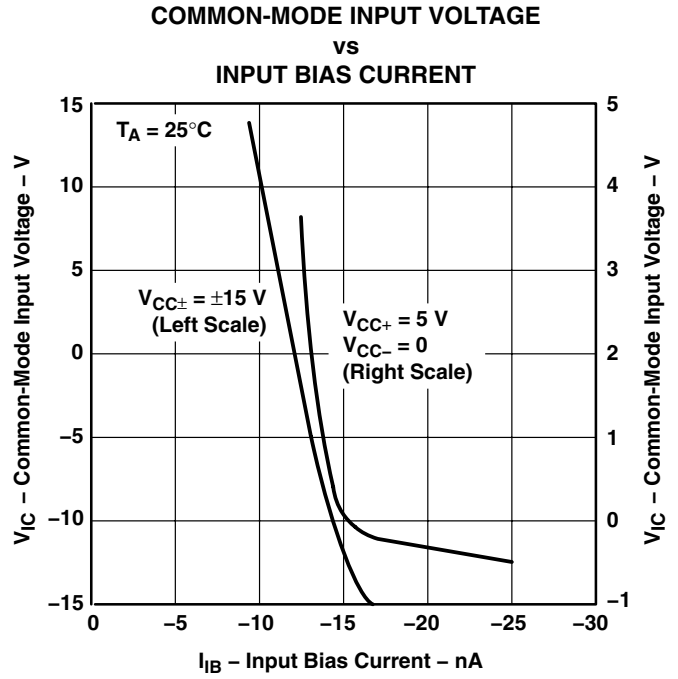
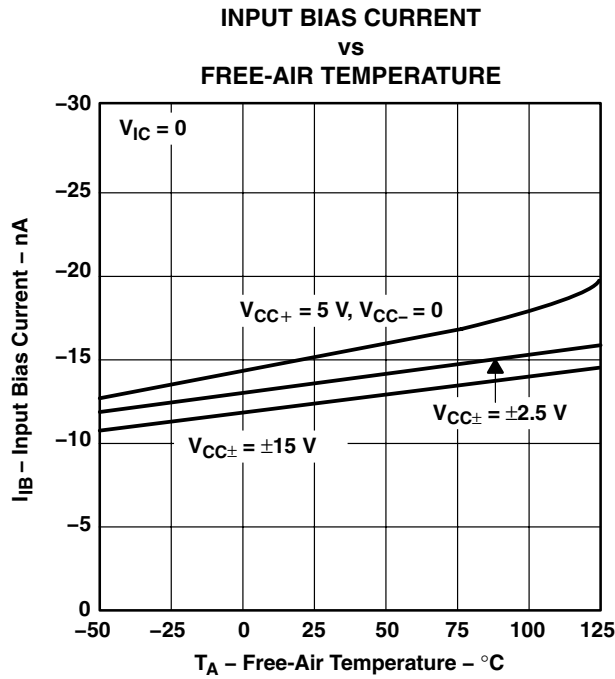

Figure 4

† Data at high and low temperatures are applicable only within the rated operating free-air temperature ranges of the various devices.

TYPICAL CHARACTERISTICS†



† Data at high and low temperatures are applicable only within the rated operating free-air temperature ranges of the various devices.

LT1014, LT1014A, LT1014D QUAD PRECISION OPERATIONAL AMPLIFIERS

SLOS039D – JULY 1989 – REVISED AUGUST 2009

TYPICAL CHARACTERISTICS†

**DIFFERENTIAL VOLTAGE AMPLIFICATION
AND PHASE SHIFT
vs
FREQUENCY**

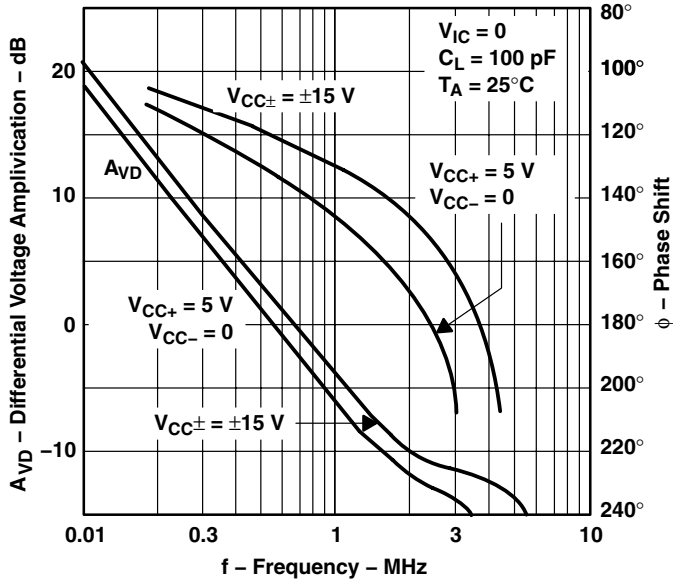

Figure 9

**DIFFERENTIAL VOLTAGE AMPLIFICATION
vs
FREQUENCY**

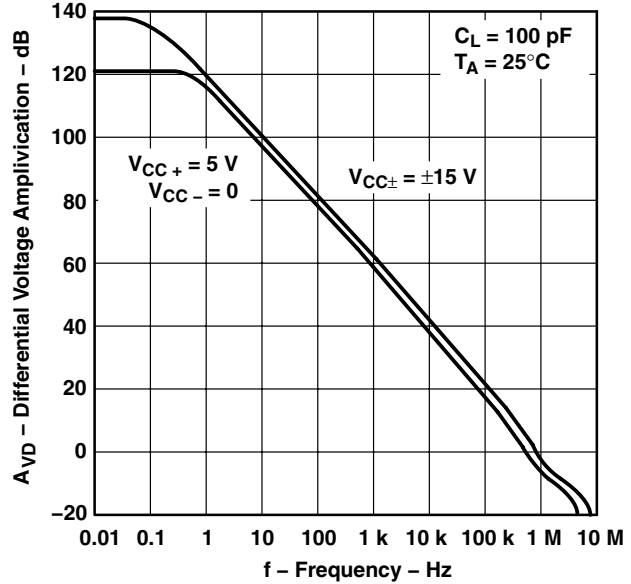

Figure 10

**CHANNEL SEPARATION
vs
FREQUENCY**

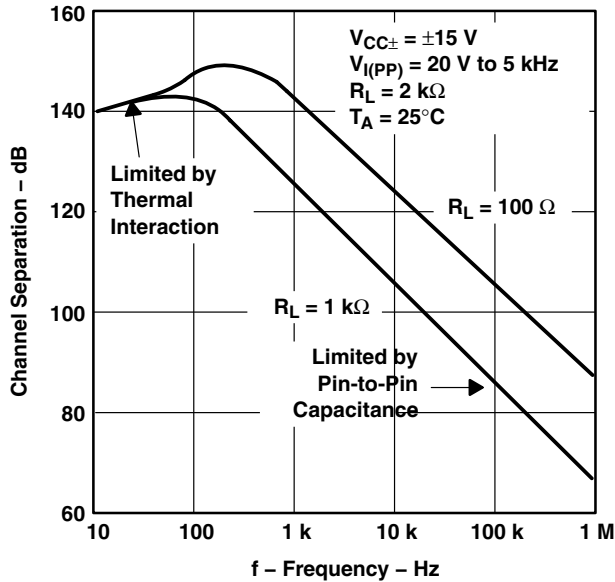

Figure 11

**OUTPUT SATURATION VOLTAGE
vs
FREE-AIR TEMPERATURE**

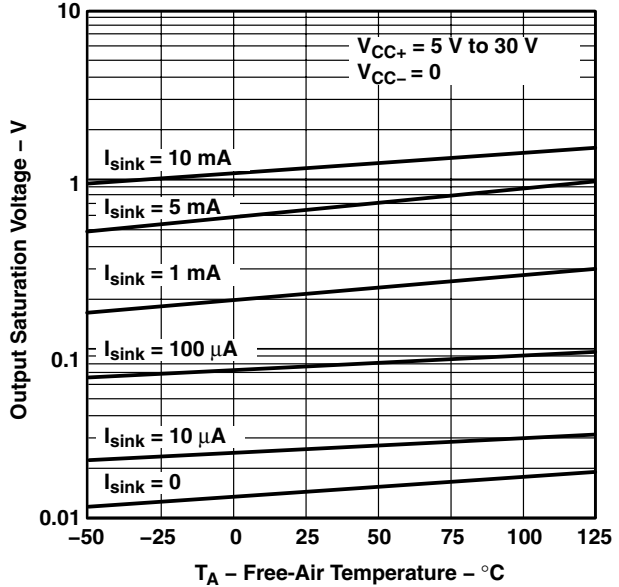
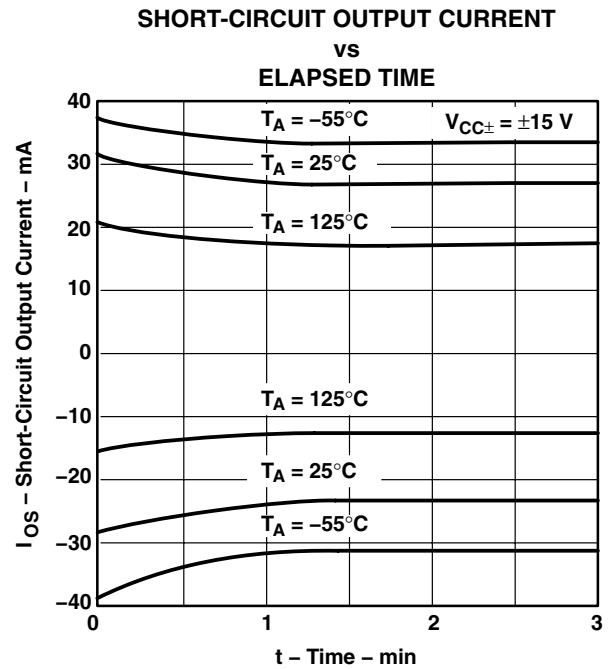
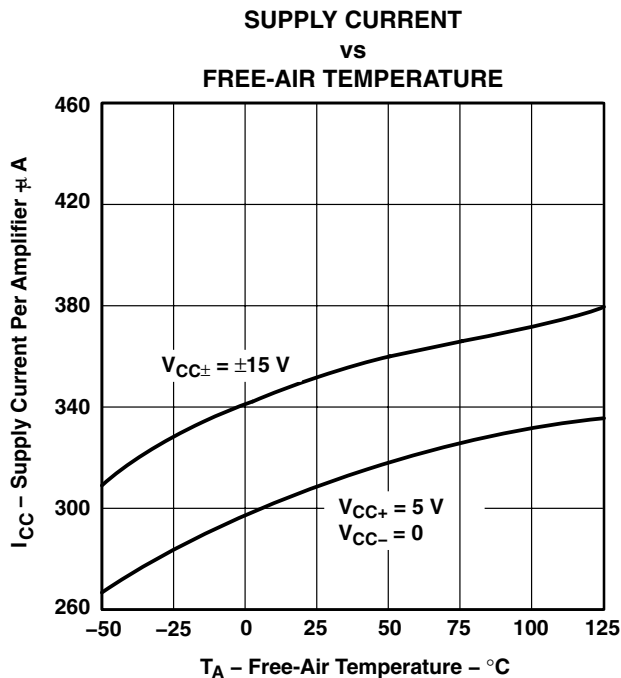
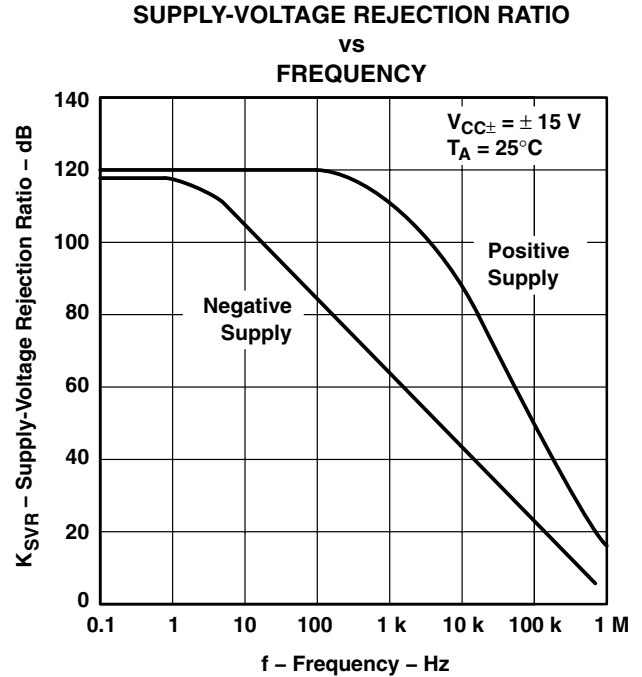
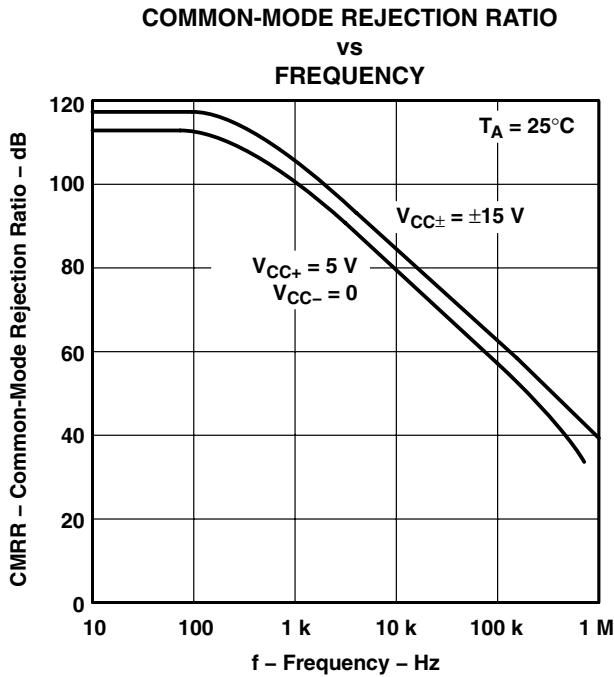

Figure 12

† Data at high and low temperatures are applicable only within the rated operating free-air temperature ranges of the various devices.

TYPICAL CHARACTERISTICS†



† Data at high and low temperatures are applicable only within the rated operating free-air temperature ranges of the various devices.

LT1014, LT1014A, LT1014D QUAD PRECISION OPERATIONAL AMPLIFIERS

SLOS039D – JULY 1989 – REVISED AUGUST 2009

TYPICAL CHARACTERISTICS

**EQUIVALENT INPUT NOISE VOLTAGE
AND EQUIVALENT INPUT NOISE CURRENT**

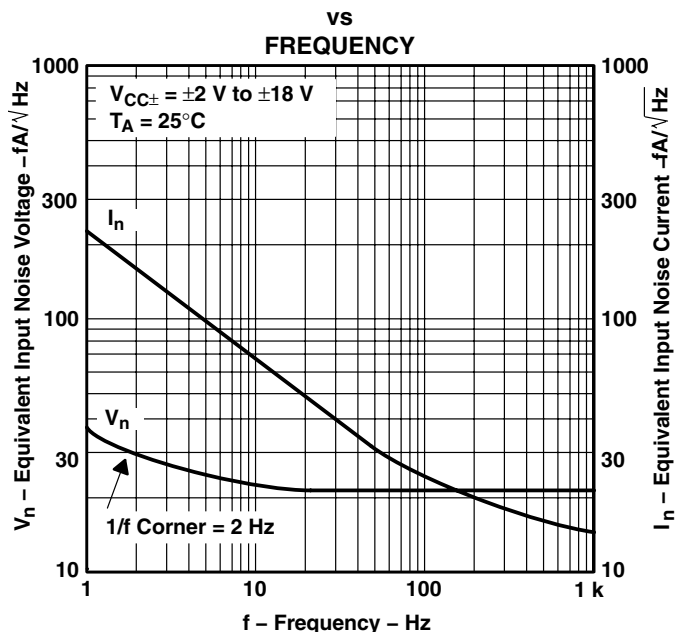

Figure 17

**PEAK-TO-PEAK INPUT NOISE VOLTAGE
OVER A 10-SECOND PERIOD**

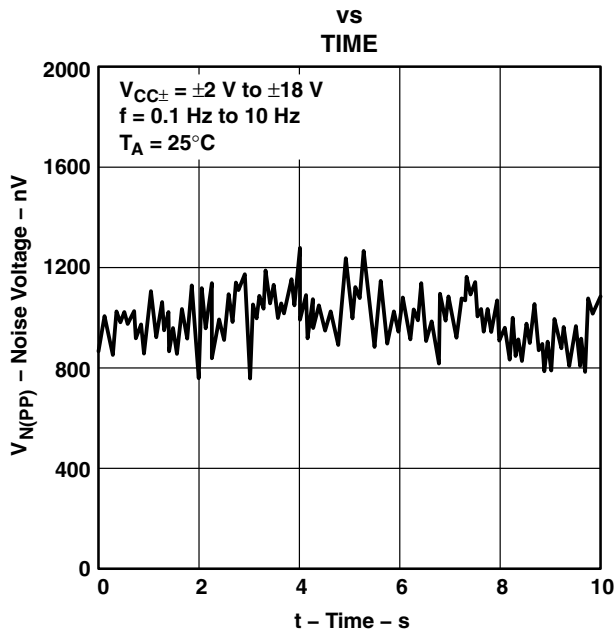

Figure 18

**VOLTAGE-FOLLOWER SMALL-SIGNAL
PULSE RESPONSE**

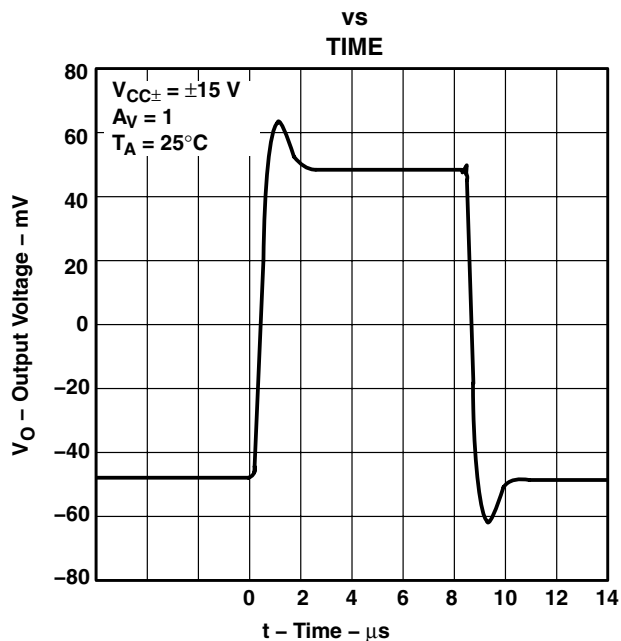

Figure 19

**VOLTAGE-FOLLOWER LARGE-SIGNAL
PULSE RESPONSE**

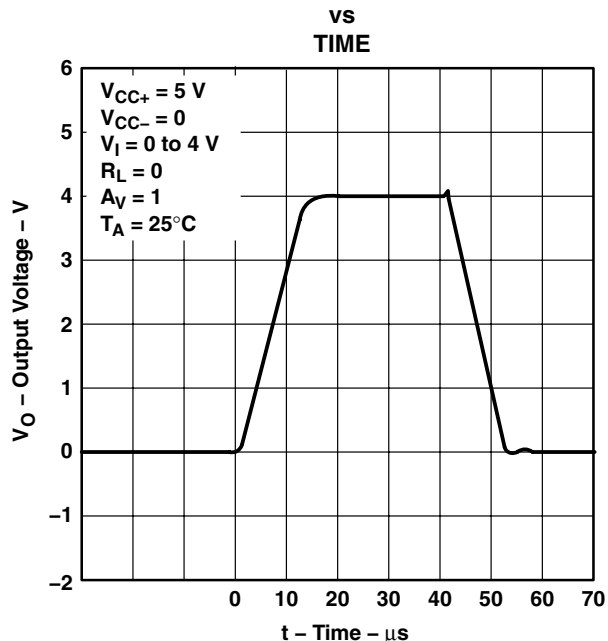

Figure 20



TYPICAL CHARACTERISTICS

VOLTAGE-FOLLOWER SMALL-SIGNAL
 PULSE RESPONSE
 vs
 TIME

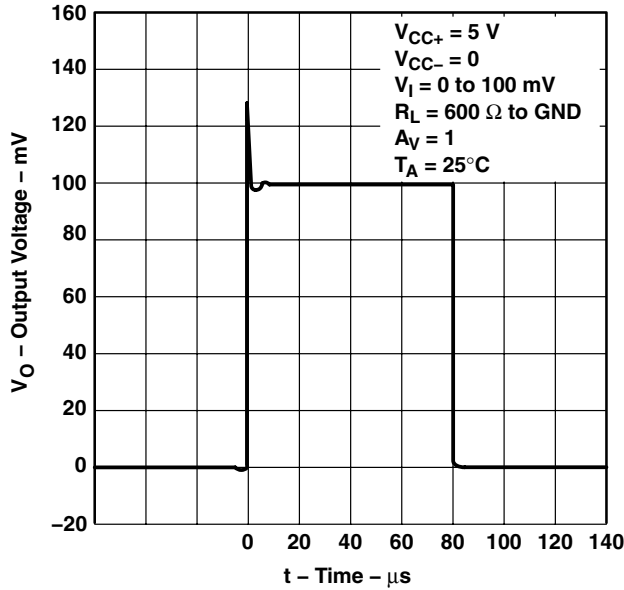

Figure 21

VOLTAGE-FOLLOWER LARGE-SIGNAL
 PULSE RESPONSE
 vs
 TIME

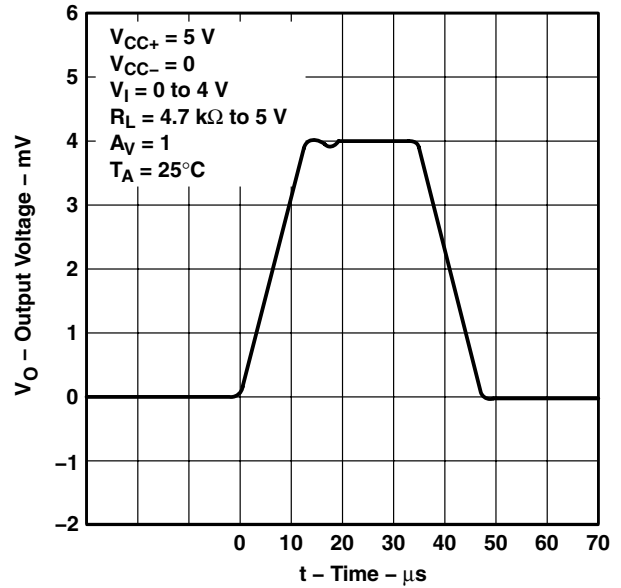

Figure 22

VOLTAGE-FOLLOWER LARGE-SIGNAL
 PULSE RESPONSE
 vs
 TIME

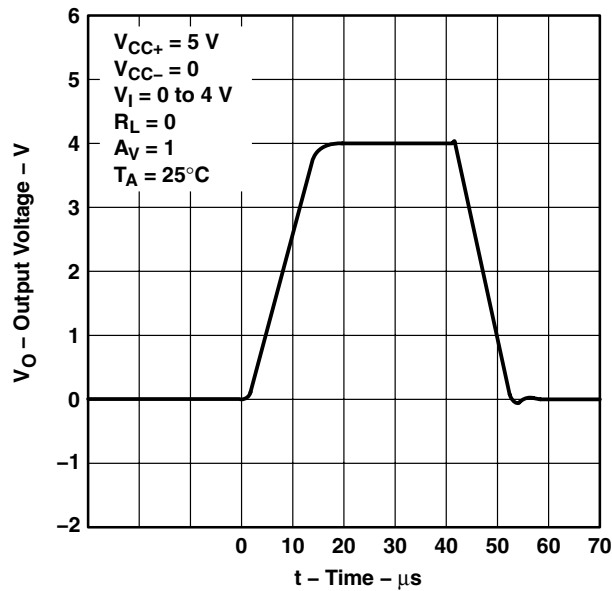

Figure 23

LT1014, LT1014A, LT1014D QUAD PRECISION OPERATIONAL AMPLIFIERS

SLOS039D – JULY 1989 – REVISED AUGUST 2009

APPLICATION INFORMATION

single-supply operation

The LT1014 is fully specified for single-supply operation ($V_{CC-} = 0$). The common-mode input voltage range includes ground, and the output swings within a few millivolts of ground.

Furthermore, the LT1014 has specific circuitry that addresses the difficulties of single-supply operation, both at the input and at the output. At the input, the driving signal can fall below 0 V, either inadvertently or on a transient basis. If the input is more than a few hundred millivolts below ground, the LT1014 is designed to deal with the following two problems that can occur:

1. On many other operational amplifiers, when the input is more than a diode drop below ground, unlimited current flows from the substrate (V_{CC-} terminal) to the input, which can destroy the unit. On the LT1014, the 400- Ω resistors in series with the input (see schematic) protect the device even when the input is 5 V below ground.
2. When the input is more than 400 mV below ground (at $T_A = 25^\circ\text{C}$), the input stage of similar type operational amplifiers saturates, and phase reversal occurs at the output. This can cause lockup in servo systems. Because of unique phase-reversal protection circuitry (Q21, Q22, Q27, and Q28), the LT1014 outputs do not reverse, even when the inputs are at -1.5 V (see Figure 24).

However, this phase-reversal protection circuitry does not function when the other operational amplifier on the LT1014 is driven hard into negative saturation at the output. Phase-reversal protection does not work on an amplifier:

- When 4's output is in negative saturation (the outputs of 2 and 3 have no effect)
- When 3's output is in negative saturation (the outputs of 1 and 4 have no effect)
- When 2's output is in negative saturation (the outputs of 1 and 4 have no effect)
- When 1's output is in negative saturation (the outputs of 2 and 3 have no effect)

At the output, other single-supply designs either cannot swing to within 600 mV of ground or cannot sink more than a few microamperes while swinging to ground. The all-npn output stage of the LT1014 maintains its low output resistance and high gain characteristics until the output is saturated. In dual-supply operations, the output stage is free of crossover distortion.

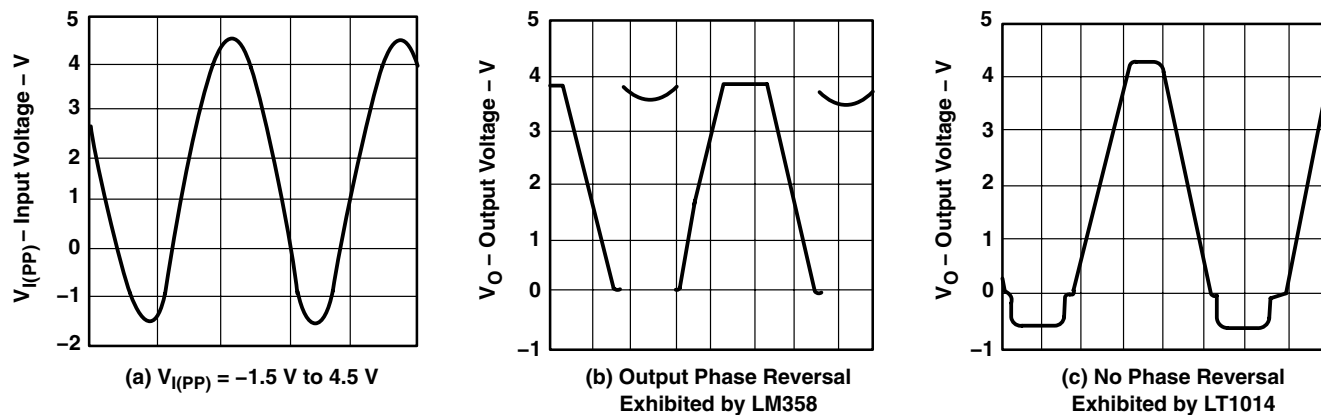

**Figure 24. Voltage-Follower Response
With Input Exceeding the Negative Common-Mode Input Voltage Range**

APPLICATION INFORMATION

comparator applications

The single-supply operation of the LT1014 can be used as a precision comparator with TTL-compatible output. In systems using both operational amplifiers and comparators, the LT1014 can perform multiple duties (see Figures 25 and 26).

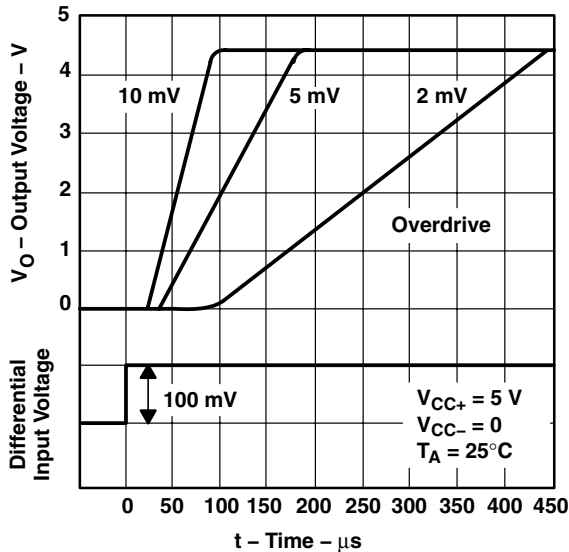

Figure 25. Low-to-High-Level Output Response for Various Input Overdrives

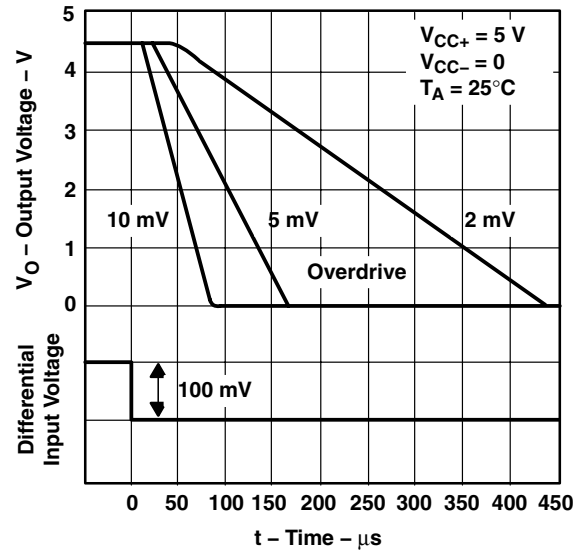

Figure 26. High-to-Low-Level Output Response for Various Input Overdrives

low-supply operation

The minimum supply voltage for proper operation of the LT1014 is 3.4 V (three Ni-Cad batteries). Typical supply current at this voltage is 290 μ A; therefore, power dissipation is only 1 mW per amplifier.

offset voltage and noise testing

Figure 30 shows the test circuit for measuring input offset voltage and its temperature coefficient. This circuit with supply voltages increased to ± 20 V is also used as the burn-in configuration.

The peak-to-peak equivalent input noise voltage of the LT1014 is measured using the test circuit shown in Figure 27. The frequency response of the noise tester indicates that the 0.1-Hz corner is defined by only one zero. The test time to measure 0.1-Hz to 10-Hz noise should not exceed 10 seconds, as this time limit acts as an additional zero to eliminate noise contribution from the frequency band below 0.1 Hz.

An input noise-voltage test is recommended when measuring the noise of a large number of units. A 10-Hz input noise-voltage measurement correlates well with a 0.1-Hz peak-to-peak noise reading because both results are determined by the white noise and the location of the 1/f corner frequency.

Noise current is measured by the circuit and formula shown in Figure 28. The noise of the source resistors is subtracted.

LT1014, LT1014A, LT1014D QUAD PRECISION OPERATIONAL AMPLIFIERS

SLOS039D – JULY 1989 – REVISED AUGUST 2009

APPLICATION INFORMATION

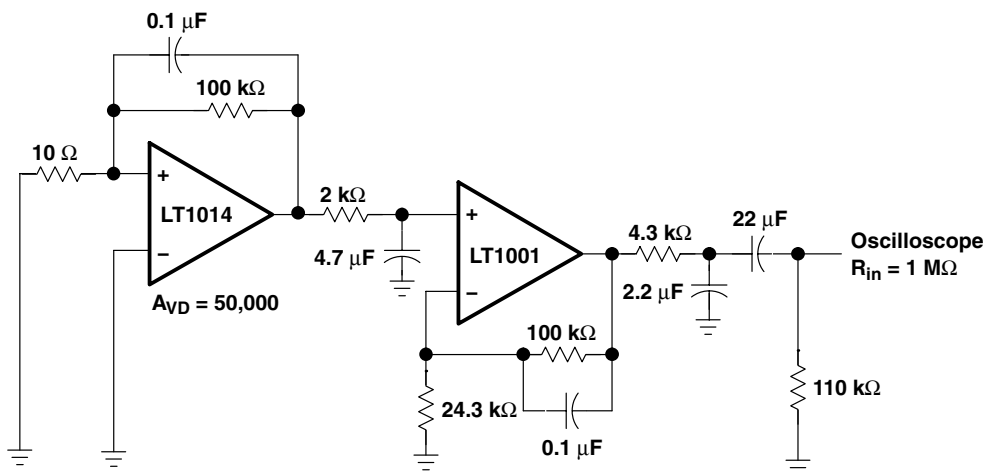

NOTE A: All capacitor values are for nonpolarized capacitors only.

Figure 27. 0.1-Hz to 10-Hz Peak-to-Peak Noise Test Circuit

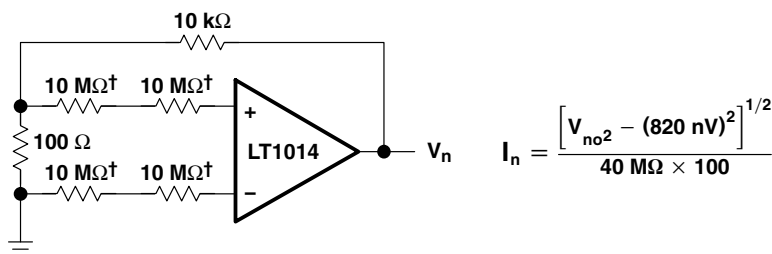

† Metal-film resistor

Figure 28. Noise-Current Test Circuit and Formula

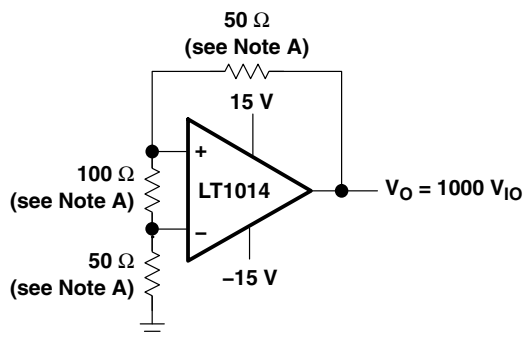

NOTE A: Resistors must have low thermoelectric potential.

Figure 29. Test Circuit for V_{IO} and αV_{IO}

APPLICATION INFORMATION

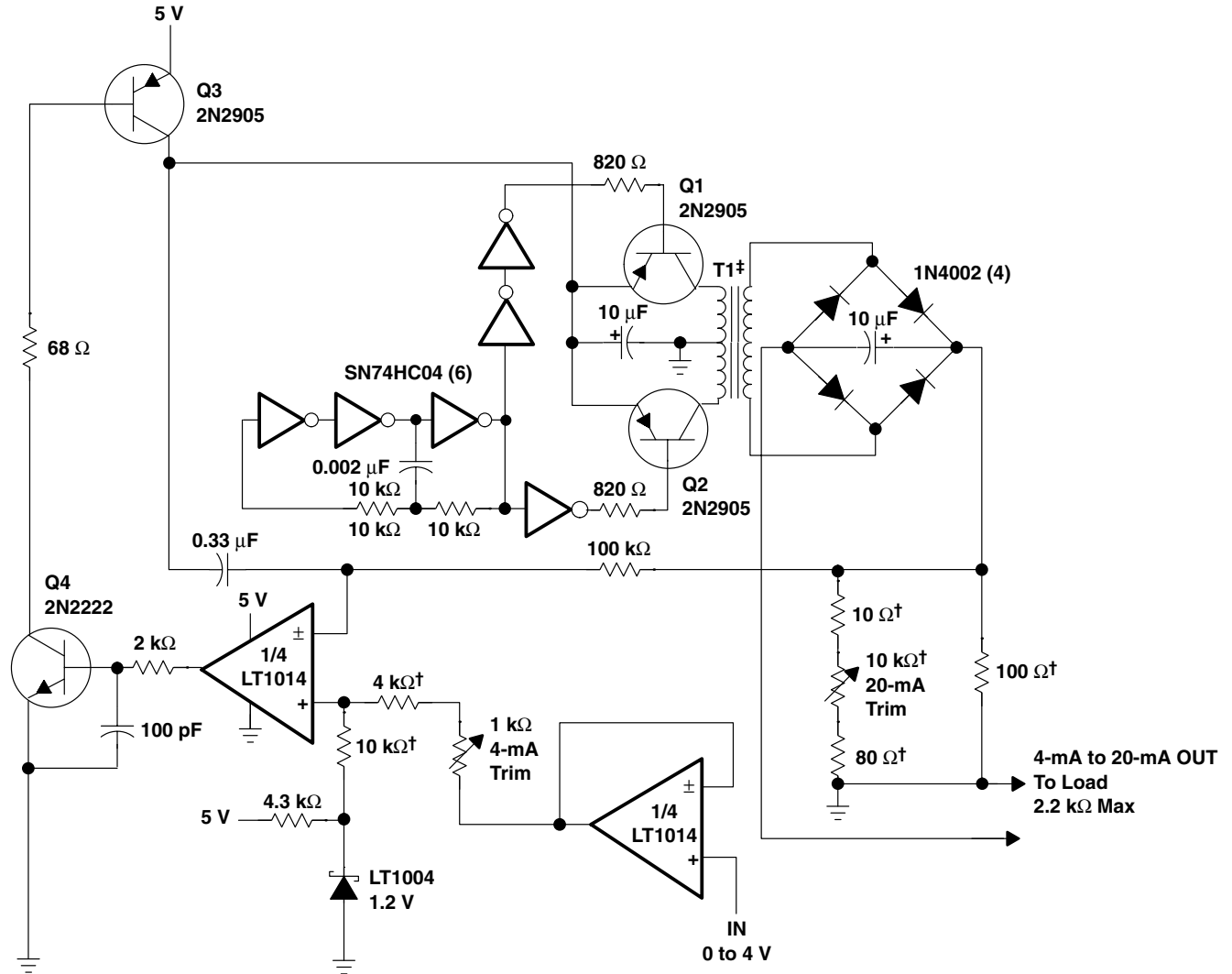

† 1% film resistor. Match 10-kΩ resistors 0.05%.

‡ T1 = PICO-31080

Figure 30. 5-V Powered, 4-mA to 20-mA Current-Loop Transmitter With 12-Bit Accuracy

LT1014, LT1014A, LT1014D QUAD PRECISION OPERATIONAL AMPLIFIERS

SLOS039D – JULY 1989 – REVISED AUGUST 2009

APPLICATION INFORMATION

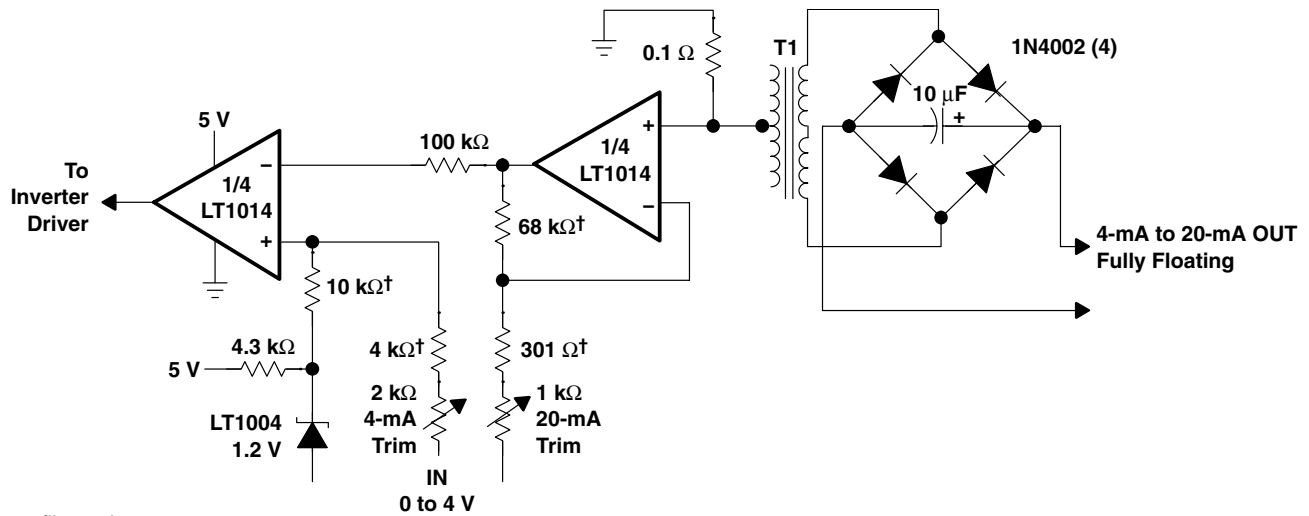

† 1% film resistor

Figure 31. Fully Floating Modification to 4-mA to 20-mA Current-Loop Transmitter With 8-Bit Accuracy

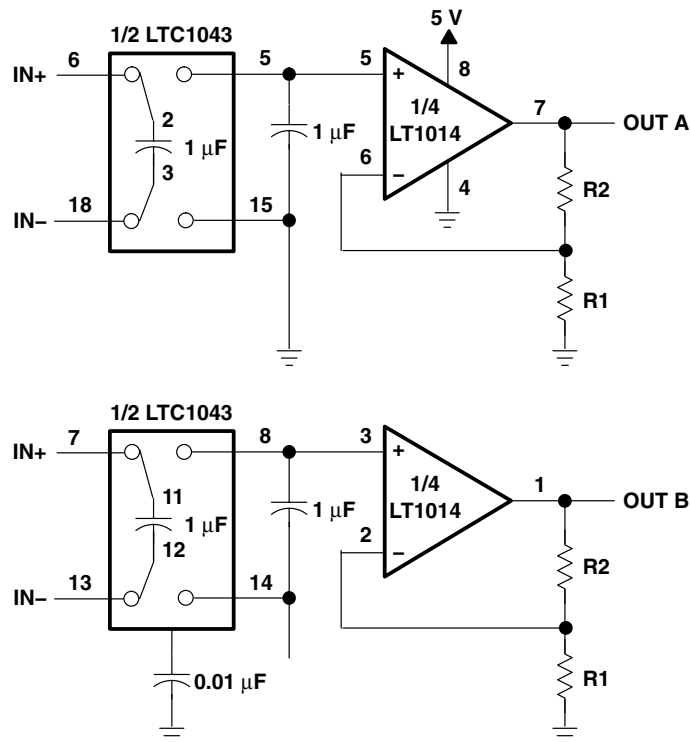

NOTE A: $V_{IO} = 150 \mu\text{V}$, $A_{VD} = (R1/R2) + 1$, $\text{CMRR} = 120 \text{ dB}$, $V_{ICR} = 0 \text{ to } 5 \text{ V}$

Figure 32. 5-V Single-Supply Dual Instrumentation Amplifier

APPLICATION INFORMATION

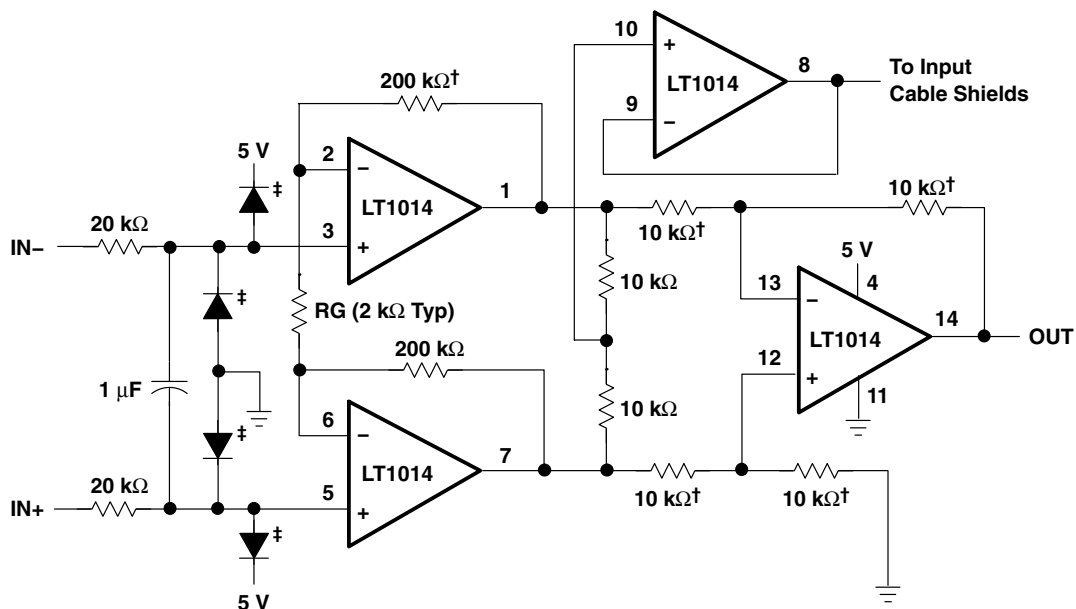

† † 1% film resistor. Match 10-kΩ resistors 0.05%.

‡ For high source impedances, use 2N2222 as diodes (with collector connected to base).

NOTE A: $A_{VD} = (400,000/RG) + 1$

Figure 33. 5-V Powered Precision Instrumentation Amplifier

PACKAGING INFORMATION

Orderable Device	Status ⁽¹⁾	Package Type	Package Drawing	Pins	Package Qty	Eco Plan ⁽²⁾	Lead/ Ball Finish	MSL Peak Temp ⁽³⁾	Samples (Requires Login)
5962-89677012A	ACTIVE	LCCC	FK	20	1	TBD	Call TI	Call TI	
5962-8967701CA	ACTIVE	CDIP	J	14	1	TBD	Call TI	Call TI	
5962-89677022A	ACTIVE	LCCC	FK	20	1	TBD	Call TI	Call TI	
5962-8967702CA	ACTIVE	CDIP	J	14	1	TBD	Call TI	Call TI	
LT1014AMFKB	ACTIVE	LCCC	FK	20	1	TBD	POST-PLATE	N / A for Pkg Type	
LT1014AMJ	ACTIVE	CDIP	J	14	1	TBD	A42	N / A for Pkg Type	
LT1014AMJB	ACTIVE	CDIP	J	14	1	TBD	A42	N / A for Pkg Type	
LT1014CN	ACTIVE	PDIP	N	14	25	Pb-Free (RoHS)	CU NIPDAU	N / A for Pkg Type	
LT1014CNE4	ACTIVE	PDIP	N	14	25	Pb-Free (RoHS)	CU NIPDAU	N / A for Pkg Type	
LT1014DDW	ACTIVE	SOIC	DW	16	40	Green (RoHS & no Sb/Br)	CU NIPDAU	Level-1-260C-UNLIM	
LT1014DDWE4	ACTIVE	SOIC	DW	16	40	Green (RoHS & no Sb/Br)	CU NIPDAU	Level-1-260C-UNLIM	
LT1014DDWG4	ACTIVE	SOIC	DW	16	40	Green (RoHS & no Sb/Br)	CU NIPDAU	Level-1-260C-UNLIM	
LT1014DDWR	ACTIVE	SOIC	DW	16	2000	Green (RoHS & no Sb/Br)	CU NIPDAU	Level-1-260C-UNLIM	
LT1014DDWRE4	ACTIVE	SOIC	DW	16	2000	Green (RoHS & no Sb/Br)	CU NIPDAU	Level-1-260C-UNLIM	
LT1014DDWRG4	ACTIVE	SOIC	DW	16	2000	Green (RoHS & no Sb/Br)	CU NIPDAU	Level-1-260C-UNLIM	
LT1014DIDW	ACTIVE	SOIC	DW	16	40	Green (RoHS & no Sb/Br)	CU NIPDAU	Level-1-260C-UNLIM	
LT1014DIDWG4	ACTIVE	SOIC	DW	16	40	Green (RoHS & no Sb/Br)	CU NIPDAU	Level-1-260C-UNLIM	
LT1014DIDWR	ACTIVE	SOIC	DW	16	2000	Green (RoHS & no Sb/Br)	CU NIPDAU	Level-1-260C-UNLIM	
LT1014DIDWRG4	ACTIVE	SOIC	DW	16	2000	Green (RoHS & no Sb/Br)	CU NIPDAU	Level-1-260C-UNLIM	
LT1014DIN	ACTIVE	PDIP	N	14	25	Pb-Free (RoHS)	CU NIPDAU	N / A for Pkg Type	
LT1014DINE4	ACTIVE	PDIP	N	14	25	Pb-Free (RoHS)	CU NIPDAU	N / A for Pkg Type	

Orderable Device	Status ⁽¹⁾	Package Type	Package Drawing	Pins	Package Qty	Eco Plan ⁽²⁾	Lead/ Ball Finish	MSL Peak Temp ⁽³⁾	Samples (Requires Login)
LT1014DMDW	ACTIVE	SOIC	DW	16	40	Green (RoHS & no Sb/Br)	CU NIPDAU	Level-1-260C-UNLIM	
LT1014DMDWG4	ACTIVE	SOIC	DW	16	40	Green (RoHS & no Sb/Br)	CU NIPDAU	Level-1-260C-UNLIM	
LT1014DN	ACTIVE	PDIP	N	14	25	Pb-Free (RoHS)	CU NIPDAU	N / A for Pkg Type	
LT1014DNE4	ACTIVE	PDIP	N	14	25	Pb-Free (RoHS)	CU NIPDAU	N / A for Pkg Type	
LT1014IN	OBSOLETE	PDIP	N	14		TBD	Call TI	Call TI	
LT1014MFKB	ACTIVE	LCCC	FK	20	1	TBD	POST-PLATE	N / A for Pkg Type	
LT1014MJ	ACTIVE	CDIP	J	14	1	TBD	A42	N / A for Pkg Type	
LT1014MJB	ACTIVE	CDIP	J	14	1	TBD	A42	N / A for Pkg Type	

⁽¹⁾ The marketing status values are defined as follows:

ACTIVE: Product device recommended for new designs.

LIFEBUY: TI has announced that the device will be discontinued, and a lifetime-buy period is in effect.

NRND: Not recommended for new designs. Device is in production to support existing customers, but TI does not recommend using this part in a new design.

PREVIEW: Device has been announced but is not in production. Samples may or may not be available.

OBSOLETE: TI has discontinued the production of the device.

⁽²⁾ Eco Plan - The planned eco-friendly classification: Pb-Free (RoHS), Pb-Free (RoHS Exempt), or Green (RoHS & no Sb/Br) - please check <http://www.ti.com/productcontent> for the latest availability information and additional product content details.

TBD: The Pb-Free/Green conversion plan has not been defined.

Pb-Free (RoHS): TI's terms "Lead-Free" or "Pb-Free" mean semiconductor products that are compatible with the current RoHS requirements for all 6 substances, including the requirement that lead not exceed 0.1% by weight in homogeneous materials. Where designed to be soldered at high temperatures, TI Pb-Free products are suitable for use in specified lead-free processes.

Pb-Free (RoHS Exempt): This component has a RoHS exemption for either 1) lead-based flip-chip solder bumps used between the die and package, or 2) lead-based die adhesive used between the die and leadframe. The component is otherwise considered Pb-Free (RoHS compatible) as defined above.

Green (RoHS & no Sb/Br): TI defines "Green" to mean Pb-Free (RoHS compatible), and free of Bromine (Br) and Antimony (Sb) based flame retardants (Br or Sb do not exceed 0.1% by weight in homogeneous material)

⁽³⁾ MSL, Peak Temp. -- The Moisture Sensitivity Level rating according to the JEDEC industry standard classifications, and peak solder temperature.

Important Information and Disclaimer: The information provided on this page represents TI's knowledge and belief as of the date that it is provided. TI bases its knowledge and belief on information provided by third parties, and makes no representation or warranty as to the accuracy of such information. Efforts are underway to better integrate information from third parties. TI has taken and continues to take reasonable steps to provide representative and accurate information but may not have conducted destructive testing or chemical analysis on incoming materials and chemicals. TI and TI suppliers consider certain information to be proprietary, and thus CAS numbers and other limited information may not be available for release.

In no event shall TI's liability arising out of such information exceed the total purchase price of the TI part(s) at issue in this document sold by TI to Customer on an annual basis.

OTHER QUALIFIED VERSIONS OF LT1014D :

- Enhanced Product: [LT1014D-EP](#)

NOTE: Qualified Version Definitions:

- Enhanced Product - Supports Defense, Aerospace and Medical Applications

TAPE AND REEL INFORMATION

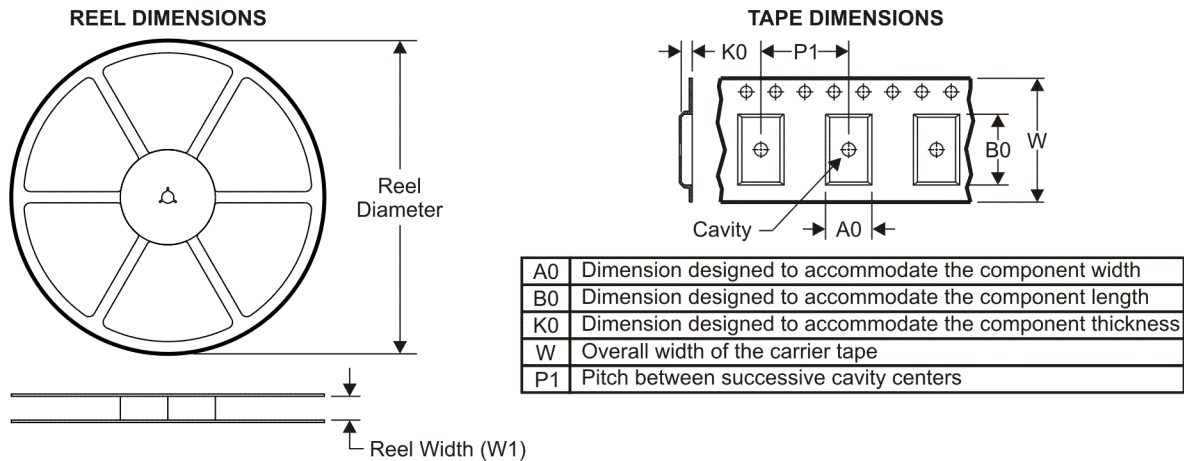

QUADRANT ASSIGNMENTS FOR PIN 1 ORIENTATION IN TAPE

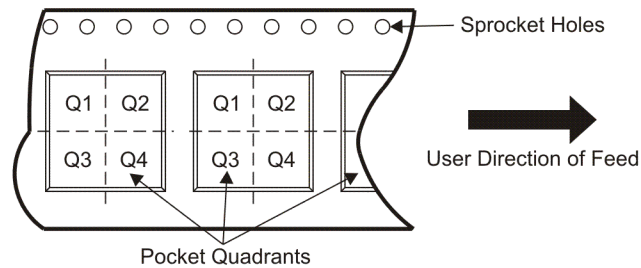

*All dimensions are nominal

Device	Package Type	Package Drawing	Pins	SPQ	Reel Diameter (mm)	Reel Width W1 (mm)	A0 (mm)	B0 (mm)	K0 (mm)	P1 (mm)	W (mm)	Pin1 Quadrant
LT1014DDWR	SOIC	DW	16	2000	330.0	16.4	10.75	10.7	2.7	12.0	16.0	Q1
LT1014DIDWR	SOIC	DW	16	2000	330.0	16.4	10.75	10.7	2.7	12.0	16.0	Q1

TAPE AND REEL BOX DIMENSIONS

*All dimensions are nominal

Device	Package Type	Package Drawing	Pins	SPQ	Length (mm)	Width (mm)	Height (mm)
LT1014DDWR	SOIC	DW	16	2000	346.0	346.0	33.0
LT1014DIDWR	SOIC	DW	16	2000	346.0	346.0	33.0

J (R-GDIP-T**)

14 LEADS SHOWN

CERAMIC DUAL IN-LINE PACKAGE



DIM \ PINS **	14	16	18	20
A	0.300 (7,62) BSC	0.300 (7,62) BSC	0.300 (7,62) BSC	0.300 (7,62) BSC
B MAX	0.785 (19,94)	.840 (21,34)	0.960 (24,38)	1.060 (26,92)
B MIN	—	—	—	—
C MAX	0.300 (7,62)	0.300 (7,62)	0.310 (7,87)	0.300 (7,62)
C MIN	0.245 (6,22)	0.245 (6,22)	0.220 (5,59)	0.245 (6,22)



4040083/F 03/03

- NOTES:
- All linear dimensions are in inches (millimeters).
 - This drawing is subject to change without notice.
 - This package is hermetically sealed with a ceramic lid using glass frit.
 - Index point is provided on cap for terminal identification only on press ceramic glass frit seal only.
 - Falls within MIL STD 1835 GDIP1-T14, GDIP1-T16, GDIP1-T18 and GDIP1-T20.

FK (S-CQCC-N**)

LEADLESS CERAMIC CHIP CARRIER

28 TERMINAL SHOWN

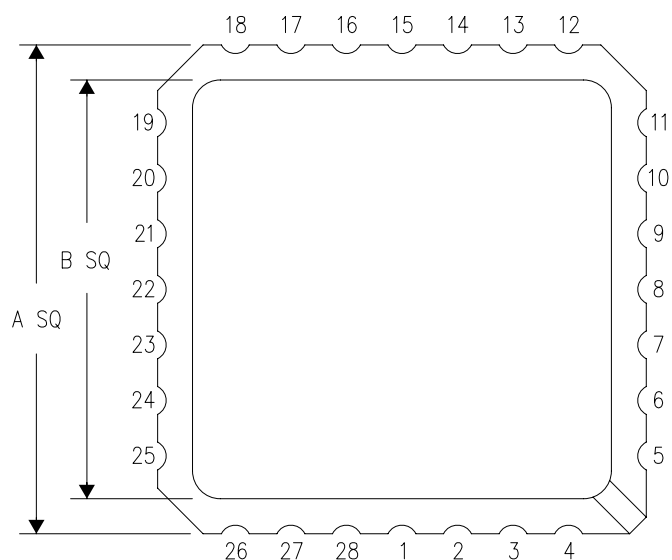

NO. OF TERMINALS **	A		B	
	MIN	MAX	MIN	MAX
20	0.342 (8,69)	0.358 (9,09)	0.307 (7,80)	0.358 (9,09)
28	0.442 (11,23)	0.458 (11,63)	0.406 (10,31)	0.458 (11,63)
44	0.640 (16,26)	0.660 (16,76)	0.495 (12,58)	0.560 (14,22)
52	0.740 (18,78)	0.761 (19,32)	0.495 (12,58)	0.560 (14,22)
68	0.938 (23,83)	0.962 (24,43)	0.850 (21,6)	0.858 (21,8)
84	1.141 (28,99)	1.165 (29,59)	1.047 (26,6)	1.063 (27,0)

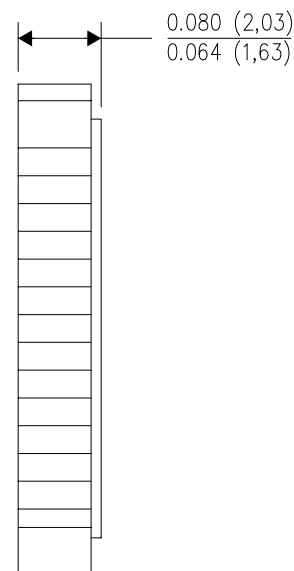
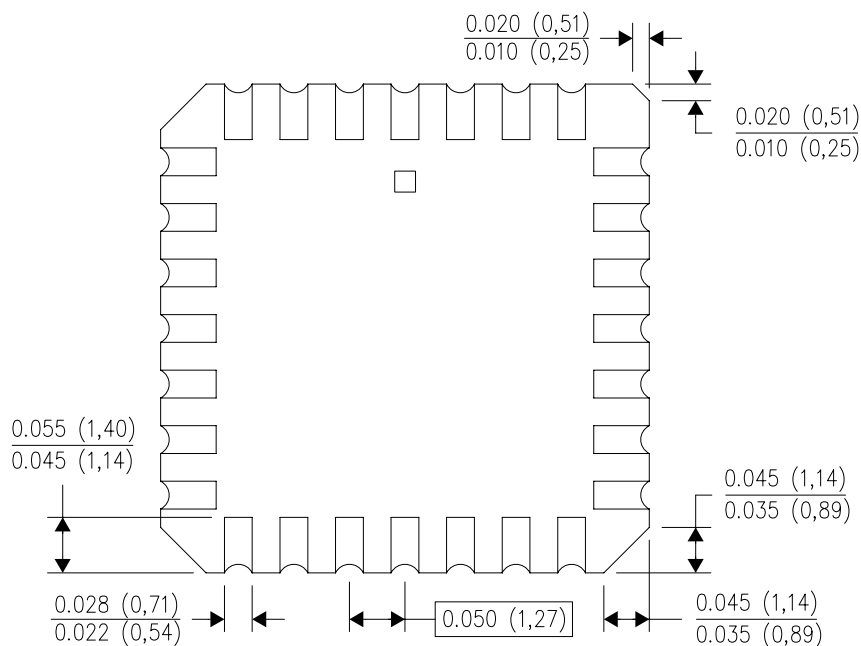

4040140/D 01/11

- NOTES:
- All linear dimensions are in inches (millimeters).
 - This drawing is subject to change without notice.
 - This package can be hermetically sealed with a metal lid.
 - Falls within JEDEC MS-004

DW (R-PDSO-G16)

PLASTIC SMALL OUTLINE

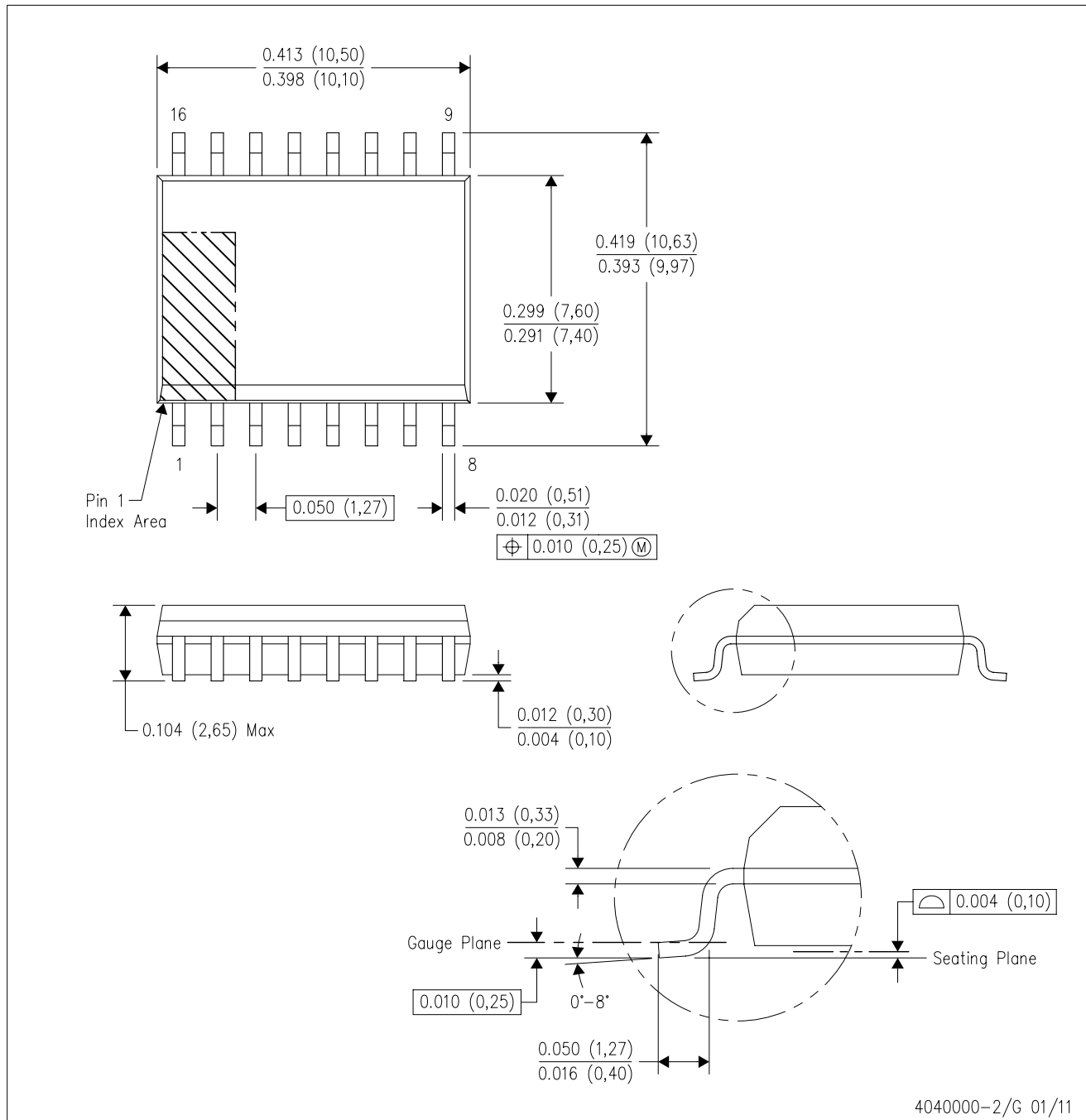

- NOTES:
- All linear dimensions are in inches (millimeters). Dimensioning and tolerancing per ASME Y14.5M-1994.
 - This drawing is subject to change without notice.
 - Body dimensions do not include mold flash or protrusion not to exceed 0.006 (0,15).
 - Falls within JEDEC MS-013 variation AA.

IMPORTANT NOTICE

Texas Instruments Incorporated and its subsidiaries (TI) reserve the right to make corrections, modifications, enhancements, improvements, and other changes to its products and services at any time and to discontinue any product or service without notice. Customers should obtain the latest relevant information before placing orders and should verify that such information is current and complete. All products are sold subject to TI's terms and conditions of sale supplied at the time of order acknowledgment.

TI warrants performance of its hardware products to the specifications applicable at the time of sale in accordance with TI's standard warranty. Testing and other quality control techniques are used to the extent TI deems necessary to support this warranty. Except where mandated by government requirements, testing of all parameters of each product is not necessarily performed.

TI assumes no liability for applications assistance or customer product design. Customers are responsible for their products and applications using TI components. To minimize the risks associated with customer products and applications, customers should provide adequate design and operating safeguards.

TI does not warrant or represent that any license, either express or implied, is granted under any TI patent right, copyright, mask work right, or other TI intellectual property right relating to any combination, machine, or process in which TI products or services are used. Information published by TI regarding third-party products or services does not constitute a license from TI to use such products or services or a warranty or endorsement thereof. Use of such information may require a license from a third party under the patents or other intellectual property of the third party, or a license from TI under the patents or other intellectual property of TI.

Reproduction of TI information in TI data books or data sheets is permissible only if reproduction is without alteration and is accompanied by all associated warranties, conditions, limitations, and notices. Reproduction of this information with alteration is an unfair and deceptive business practice. TI is not responsible or liable for such altered documentation. Information of third parties may be subject to additional restrictions.

Resale of TI products or services with statements different from or beyond the parameters stated by TI for that product or service voids all express and any implied warranties for the associated TI product or service and is an unfair and deceptive business practice. TI is not responsible or liable for any such statements.

TI products are not authorized for use in safety-critical applications (such as life support) where a failure of the TI product would reasonably be expected to cause severe personal injury or death, unless officers of the parties have executed an agreement specifically governing such use. Buyers represent that they have all necessary expertise in the safety and regulatory ramifications of their applications, and acknowledge and agree that they are solely responsible for all legal, regulatory and safety-related requirements concerning their products and any use of TI products in such safety-critical applications, notwithstanding any applications-related information or support that may be provided by TI. Further, Buyers must fully indemnify TI and its representatives against any damages arising out of the use of TI products in such safety-critical applications.

TI products are neither designed nor intended for use in military/aerospace applications or environments unless the TI products are specifically designated by TI as military-grade or "enhanced plastic." Only products designated by TI as military-grade meet military specifications. Buyers acknowledge and agree that any such use of TI products which TI has not designated as military-grade is solely at the Buyer's risk, and that they are solely responsible for compliance with all legal and regulatory requirements in connection with such use.

TI products are neither designed nor intended for use in automotive applications or environments unless the specific TI products are designated by TI as compliant with ISO/TS 16949 requirements. Buyers acknowledge and agree that, if they use any non-designated products in automotive applications, TI will not be responsible for any failure to meet such requirements.

Following are URLs where you can obtain information on other Texas Instruments products and application solutions:

Products

Audio	www.ti.com/audio
Amplifiers	amplifier.ti.com
Data Converters	dataconverter.ti.com
DLP® Products	www.dlp.com
DSP	dsp.ti.com
Clocks and Timers	www.ti.com/clocks
Interface	interface.ti.com
Logic	logic.ti.com
Power Mgmt	power.ti.com
Microcontrollers	microcontroller.ti.com
RFID	www.ti-rfid.com
OMAP Mobile Processors	www.ti.com/omap
Wireless Connectivity	www.ti.com/wirelessconnectivity

Applications

Automotive and Transportation	www.ti.com/automotive
Communications and Telecom	www.ti.com/communications
Computers and Peripherals	www.ti.com/computers
Consumer Electronics	www.ti.com/consumer-apps
Energy and Lighting	www.ti.com/energy
Industrial	www.ti.com/industrial
Medical	www.ti.com/medical
Security	www.ti.com/security
Space, Avionics and Defense	www.ti.com/space-avionics-defense
Video and Imaging	www.ti.com/video

TI E2E Community Home Page

e2e.ti.com

Mailing Address: Texas Instruments, Post Office Box 655303, Dallas, Texas 75265
Copyright © 2012, Texas Instruments Incorporated