

采用四方扁平无引线 (QFN) 封装且具有 2.95V-17V 输入电压和电流均流功能的 7A SIMPLE SWITCHER® 电源模块

 查询样片: [LMZ31707](#)

特性

- 完整的集成式电源解决方案可实现小型器件封装、半高设计
- 10mm x 10mm x 4.3mm** 封装
 - 与 **LMZ31710 & LMZ31704** 引脚兼容
- 效率高达 **95%**
- Eco-mode™** / 轻负载效率 (LLE)
- 宽输出电压调节范围 **0.6V 至 5.5V**，基准精度为 **1%**
- 支持针对更高电流的并联运行
- 可选分离电源轨可实现低至 **2.95V** 的输入电压
- 可调开关频率 (**200kHz 至 1.2MHz**)
- 与一个外部时钟同步
- 提供 **180°** 异相位时钟信号
- 可调节缓启动
- 输出电压排序/跟踪
- 电源正常输出
- 可编程欠压锁定 (**UVLO**)
- 过流 & 过热保护
- 预偏置输出启动
- 运行温度范围: **-40°C 至 85°C**
- 增强散热性能: **13.3°C/W**
- 符合 **EN55022 B** 类辐射标准
 - 集成屏蔽式电感器

应用范围

- 宽带和通信基础设施
- 自动化测试和医疗设备
- 紧凑型外设组件互连接口 (**PCI**) / **PCI** 快速接口 / **PCI** 扩展 (**PXI**) 快速接口
- 数字信号处理器 (**DSP**) 和现场可编程门阵列 (**FPGA**) 负载点应用

说明

LMZ31707 SIMPLE SWITCHER® 电源模块是一款易于使用的集成式电源解决方案，此方案在一半高的 QFN 封装内组合了一个带有功率金属氧化物半导体场效应管 (MOSFET) 的 7A 直流/直流转换器、一个屏蔽电感器以及无源元件。这个整体电源解决方案仅需三个外部元件，并免除了环路补偿和磁性部件选择过程。

10mm x 10mm x 4.3mm QFN 封装可以很轻松地焊接到一个印刷电路板上，并且可实现一个紧凑的负载点设计。可实现 95% 以上的效率以及热阻抗为 13.3°C/W 的出色功率耗散能力。LMZ31707 提供离散负载点设计的灵活性和特性集，并且非常适合为广泛的集成电路 (IC) 和系统供电。先进的封装技术可提供一个与标准 QFN 贴装和测试技术兼容的稳健耐用且可靠的电源解决方案。

图 1. 简化的应用

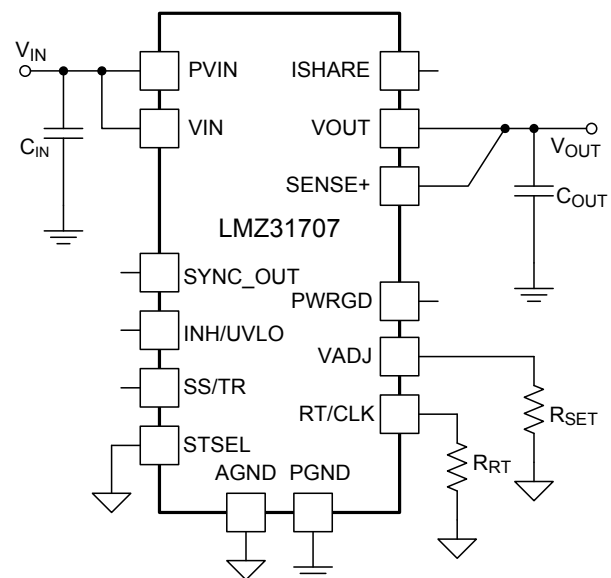

This integrated circuit can be damaged by ESD. Texas Instruments recommends that all integrated circuits be handled with appropriate precautions. Failure to observe proper handling and installation procedures can cause damage.

ESD damage can range from subtle performance degradation to complete device failure. Precision integrated circuits may be more susceptible to damage because very small parametric changes could cause the device not to meet its published specifications.



Please be aware that an important notice concerning availability, standard warranty, and use in critical applications of Texas Instruments semiconductor products and disclaimers thereto appears at the end of this data sheet.

Eco-mode is a trademark of Texas Instruments.

SIMPLE SWITCHER is a registered trademark of Texas Instruments.

ABSOLUTE MAXIMUM RATINGS⁽¹⁾

Over Operating Temperature Range (Unless Otherwise Noted)		MIN	MAX	UNIT
Input Voltage	VIN, PVIN	-0.3	20	V
	INH/UVLO, PWRGD, RT/CLK, SENSE+	-0.3	6	V
	ILIM, VADJ, SS/TR, STSEL, SYNC_OUT, ISHARE, OCP_SEL	-0.3	3	V
Output Voltage	PH	-1.0	20	V
	PH 10ns Transient	-3.0	20	V
	VOUT	-0.3	6	V
Source Current	RT/CLK, INH/UVLO		±100	µA
	PH		current limit	A
Sink Current	PH		current limit	A
	PVIN		current limit	A
	PWRGD	-0.1	2	mA
Operating Junction Temperature		-40	125 ⁽²⁾	°C
Storage Temperature		-65	150	°C
Mechanical Shock	Mil-STD-883D, Method 2002.3, 1 msec, 1/2 sine, mounted		1500	G
Mechanical Vibration	Mil-STD-883D, Method 2007.2, 20-2000Hz		20	

- (1) Stresses beyond those listed under absolute maximum ratings may cause permanent damage to the device. These are stress ratings only, and functional operation of the device at these or any other conditions beyond those indicated under recommended operating conditions is not implied. Exposure to absolute-maximum-rated conditions for extended periods may affect device reliability.
- (2) See the temperature derating curves in the Typical Characteristics section for thermal information.

RECOMMENDED OPERATING CONDITIONS

Over Operating Free-Air Temperature Range (Unless Otherwise Noted)		MIN	NOM	MAX	UNIT
PVIN	Input Switching Voltage	2.95		17	V
VIN	Input Bias Voltage	4.5		17	V
VOUT	Output Voltage	0.6		5.5	V
f _{SW}	Switching Frequency	200		1200	kHz

PACKAGE SPECIFICATIONS

LMZ31707		UNIT
Weight		1.45 grams
Flammability	Meets UL 94 V-O	
MTBF Calculated reliability	Per Bellcore TR-332, 50% stress, T _A = 40°C, ground benign	37.4 Mhrs

Table 1. ORDERING INFORMATION

For the most current package and ordering information, see the Package Option Addendum at the end of this datasheet, or see the TI website at www.ti.com.

ELECTRICAL CHARACTERISTICS

Over -40°C to 85°C free-air temperature, $P_{VIN} = V_{IN} = 12\text{ V}$, $V_{OUT} = 1.8\text{ V}$, $I_{OUT} = 7\text{ A}$,
 $C_{IN} = 0.1\text{ }\mu\text{F} + 2 \times 22\text{ }\mu\text{F}$ ceramic + $100\text{ }\mu\text{F}$ bulk, $C_{OUT} = 4 \times 47\text{ }\mu\text{F}$ ceramic (unless otherwise noted) ⁽¹⁾

PARAMETER		TEST CONDITIONS	MIN	TYP	MAX	UNIT	
I_{OUT}	Output current	$T_A = 85^{\circ}\text{C}$, natural convection	0		7	A	
V_{IN}	Input bias voltage range	Over output current range	4.5		17	V	
P_{VIN}	Input switching voltage range	Over output current range	2.95 ⁽²⁾		17 ⁽³⁾	V	
UVLO	V_{IN} Undervoltage lockout	V_{IN} Increasing		4.0	4.5	V	
		V_{IN} Decreasing	3.5	3.85			
$V_{OUT(adj)}$	Output voltage adjust range	Over output current range	0.6		5.5	V	
V_{OUT}	Set-point voltage tolerance	$T_A = 25^{\circ}\text{C}$, $I_{OUT} = 0\text{ A}$			$\pm 1\%$ ⁽⁴⁾		
	Temperature variation	$-40^{\circ}\text{C} \leq T_A \leq +85^{\circ}\text{C}$, $I_{OUT} = 0\text{ A}$		$\pm 0.2\%$			
	Line regulation	Over input voltage range		$\pm 0.1\%$			
	Load regulation	Over output current range		$\pm 0.2\%$			
	Total output voltage variation	Includes set-point, line, load, and temperature variation			$\pm 1.5\%$ ⁽⁴⁾		
η	Efficiency	$P_{VIN} = V_{IN} = 12\text{ V}$ $I_O = 4\text{ A}$	$V_{OUT} = 5.0\text{ V}$, $f_{SW} = 1\text{ MHz}$		94 %		
			$V_{OUT} = 3.3\text{ V}$, $f_{SW} = 750\text{ kHz}$		92 %		
			$V_{OUT} = 2.5\text{ V}$, $f_{SW} = 750\text{ kHz}$		90 %		
			$V_{OUT} = 1.8\text{ V}$, $f_{SW} = 500\text{ kHz}$		89 %		
			$V_{OUT} = 1.2\text{ V}$, $f_{SW} = 300\text{ kHz}$		87 %		
			$V_{OUT} = 0.9\text{ V}$, $f_{SW} = 250\text{ kHz}$		85 %		
			$V_{OUT} = 0.6\text{ V}$, $f_{SW} = 200\text{ kHz}$		82 %		
		$P_{VIN} = V_{IN} = 5\text{ V}$ $I_O = 4\text{ A}$	$V_{OUT} = 3.3\text{ V}$, $f_{SW} = 750\text{ kHz}$		95 %		
			$V_{OUT} = 2.5\text{ V}$, $f_{SW} = 750\text{ kHz}$		93 %		
			$V_{OUT} = 1.8\text{ V}$, $f_{SW} = 500\text{ kHz}$		92 %		
			$V_{OUT} = 1.2\text{ V}$, $f_{SW} = 300\text{ kHz}$		90 %		
			$V_{OUT} = 0.9\text{ V}$, $f_{SW} = 250\text{ kHz}$		87 %		
			$V_{OUT} = 0.6\text{ V}$, $f_{SW} = 200\text{ kHz}$		84 %		
			Output voltage ripple	20 MHz bandwidth		14	
I_{LIM}	Current limit threshold	ILIM pin open		12		A	
		ILIM pin to AGND		9		A	
Transient response	1.0 A/ μs load step from 25 to 75% $I_{OUT(max)}$	Recovery time		tbd		μs	
		V_{OUT} over/undershoot		tbd		mV	
V_{INH}	Inhibit threshold voltage	Inhibit High Voltage	1.3		open ⁽⁵⁾	V	
		Inhibit Low Voltage	-0.3		1.1		
I_{INH}	INH Input current	$V_{INH} < 1.1\text{ V}$		-1.15		μA	
	INH Hysteresis current	$V_{INH} > 1.3\text{ V}$		-3.3		μA	
$I_{I(stby)}$	Input standby current	INH pin to AGND		2	10	μA	
Power Good	PWRGD Thresholds	V_{OUT} rising	Good		95%		
			Fault		108%		
		V_{OUT} falling	Fault		91%		
			Good		104%		
PWRGD Low Voltage	$I(PWRGD) = 0.5\text{ mA}$			0.3	V		
f_{SW}	Switching frequency	$R_{RT} = 169\text{ k}\Omega$	400	500	600	kHz	

- (1) See the [Light Load Efficiency \(LLE\)](#) section for more information for output voltages $< 1.5\text{ V}$.
- (2) The minimum P_{VIN} is 2.95 V or $(V_{OUT} + 0.7\text{ V})$, whichever is greater. See [Table 9](#) for more details.
- (3) The maximum P_{VIN} voltage is 17 V or $(22 \times V_{OUT})$, whichever is less. See [Table 9](#) for more details.
- (4) The stated limit of the set-point voltage tolerance includes the tolerance of both the internal voltage reference and the internal adjustment resistor. The overall output voltage tolerance will be affected by the tolerance of the external R_{SET} resistor.
- (5) This pin has an internal pull-up. If it is left open, the device operates when input power is applied. A small, low-leakage MOSFET is recommended for control. When the device is operating and no UVLO resistor divider is present on this pin, the open voltage is typically 2.9 V .

ELECTRICAL CHARACTERISTICS (continued)

Over -40°C to 85°C free-air temperature, $PV_{\text{IN}} = V_{\text{IN}} = 12\text{ V}$, $V_{\text{OUT}} = 1.8\text{ V}$, $I_{\text{OUT}} = 7\text{ A}$,
 $C_{\text{IN}} = 0.1\text{ }\mu\text{F} + 2 \times 22\text{ }\mu\text{F}$ ceramic + $100\text{ }\mu\text{F}$ bulk, $C_{\text{OUT}} = 4 \times 47\text{ }\mu\text{F}$ ceramic (unless otherwise noted) ⁽¹⁾

PARAMETER		TEST CONDITIONS	MIN	TYP	MAX	UNIT
f_{CLK}	Synchronization frequency	CLK Control	200		1200	kHz
$V_{\text{CLK-H}}$	CLK High-Level		2.0		5.5	V
$V_{\text{CLK-L}}$	CLK Low-Level				0.5	V
D_{CLK}	CLK Duty Cycle		20	50	80	%
Thermal Shutdown		Thermal shutdown		175		$^{\circ}\text{C}$
		Thermal shutdown hysteresis		10		$^{\circ}\text{C}$
C_{IN}	External input capacitance	Ceramic	44 ⁽⁶⁾			μF
		Non-ceramic		100 ⁽⁶⁾		
C_{OUT}	External output capacitance	Ceramic	47 ⁽⁷⁾	200	1500	μF
		Non-ceramic		220 ⁽⁷⁾	5000 ⁽⁸⁾	
		Equivalent series resistance (ESR)				35

- (6) A minimum of $44\text{ }\mu\text{F}$ of external ceramic capacitance is required across the input (V_{IN} and PV_{IN} connected) for proper operation. An additional $100\text{ }\mu\text{F}$ of bulk capacitance is recommended. It is also recommended to place a $0.1\text{ }\mu\text{F}$ ceramic capacitor directly across the PV_{IN} and PGND pins of the device. Locate the input capacitance close to the device. When operating with split V_{IN} and PV_{IN} rails, place $4.7\text{ }\mu\text{F}$ of ceramic capacitance directly at the V_{IN} pin. See [Table 6](#) for more details.
- (7) The amount of required output capacitance varies depending on the output voltage (see [Table 5](#)). The amount of required capacitance must include at least $1 \times 47\text{ }\mu\text{F}$ ceramic capacitor. Locate the capacitance close to the device. Adding additional capacitance close to the load improves the response of the regulator to load transients. See [Table 5](#) and [Table 6](#) more details.
- (8) When using both ceramic and non-ceramic output capacitors, the combined maximum must not exceed $5000\text{ }\mu\text{F}$. It may be necessary to increase the slow start time when turning on into the maximum capacitance. See the [Slow Start \(SS/TR\)](#) section for information on adjusting the slow start time.

THERMAL INFORMATION

THERMAL METRIC ⁽¹⁾		LMZ31707	UNIT
		RVQ42	
		42 PINS	
θ_{JA}	Junction-to-ambient thermal resistance ⁽²⁾	13.3	$^{\circ}\text{C}/\text{W}$
ψ_{JT}	Junction-to-top characterization parameter ⁽³⁾	1.6	
ψ_{JB}	Junction-to-board characterization parameter ⁽⁴⁾	5.3	

- (1) For more information about traditional and new thermal metrics, see the IC Package Thermal Metrics application report (literature number [SPRA953](#)).
- (2) The junction-to-ambient thermal resistance, θ_{JA} , applies to devices soldered directly to a $100\text{ mm} \times 100\text{ mm}$ double-sided PCB with 2 oz. copper and natural convection cooling. Additional airflow reduces θ_{JA} .
- (3) The junction-to-top characterization parameter, ψ_{JT} , estimates the junction temperature, T_{J} , of a device in a real system, using a procedure described in JESD51-2A (sections 6 and 7). $T_{\text{J}} = \psi_{\text{JT}} * P_{\text{dis}} + T_{\text{T}}$; where P_{dis} is the power dissipated in the device and T_{T} is the temperature of the top of the device.
- (4) The junction-to-board characterization parameter, ψ_{JB} , estimates the junction temperature, T_{J} , of a device in a real system, using a procedure described in JESD51-2A (sections 6 and 7). $T_{\text{J}} = \psi_{\text{JB}} * P_{\text{dis}} + T_{\text{B}}$; where P_{dis} is the power dissipated in the device and T_{B} is the temperature of the board 1mm from the device.

DEVICE INFORMATION
FUNCTIONAL BLOCK DIAGRAM

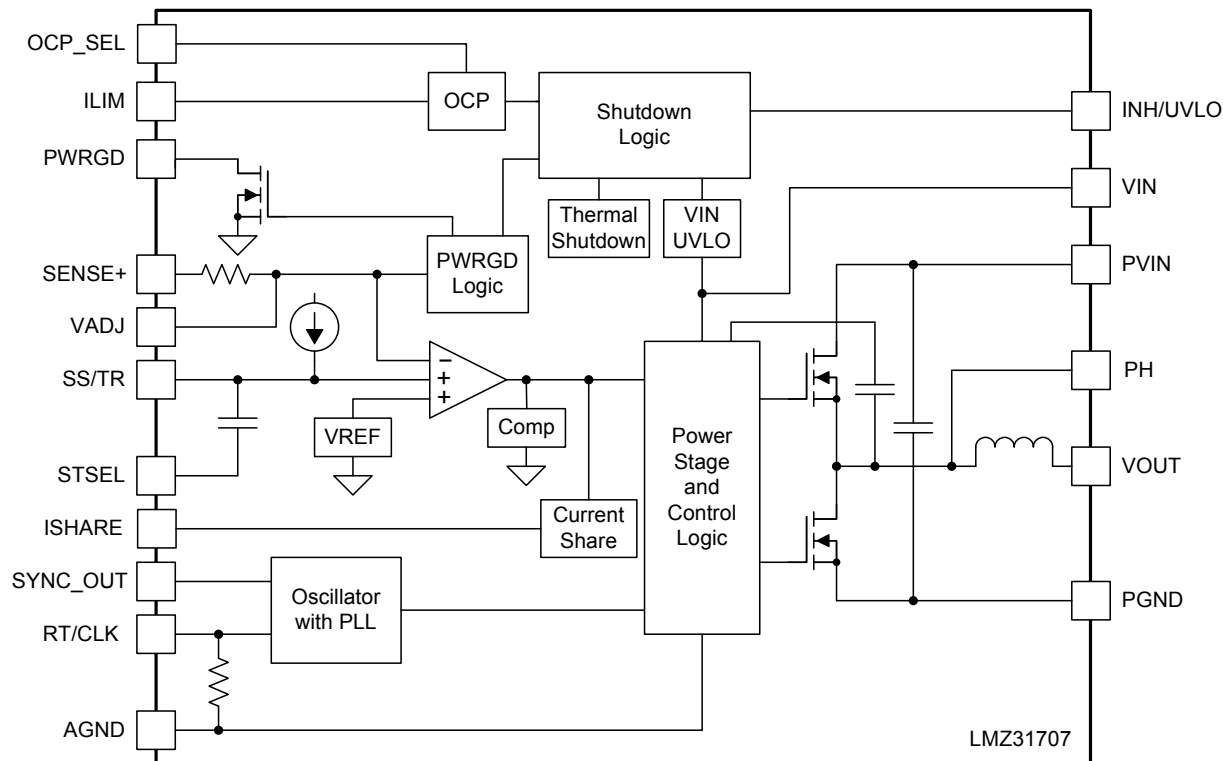
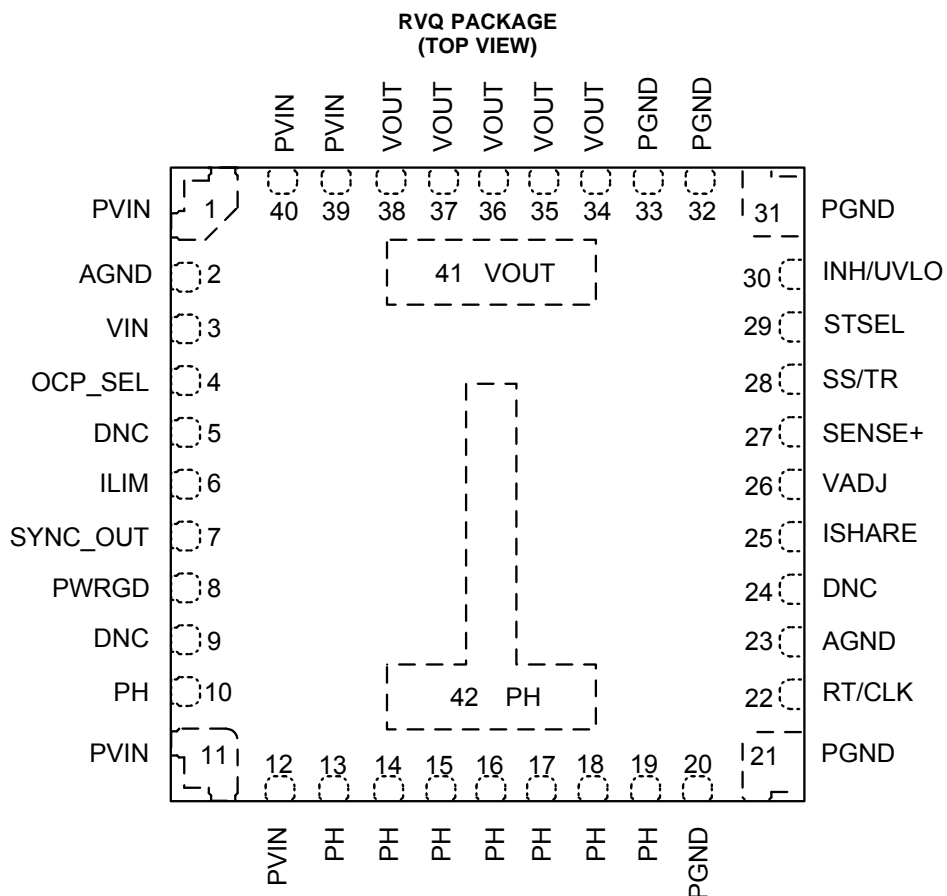

Table 2. PIN DESCRIPTIONS

TERMINAL		DESCRIPTION
NAME	NO.	
AGND	2	Zero volt reference for the analog control circuit. These pins are not connected together internal to the device and must be connected to one another using an AGND plane of the PCB. These pins are associated with the internal analog ground (AGND) of the device. See Layout Recommendations.
	23	
PGND	20	This is the return current path for the power stage of the device. Connect these pins to the load and to the bypass capacitors associated with PVIN and VOUT.
	21	
	31	
	32	
	33	
VIN	3	Input bias voltage pin. Supplies the control circuitry of the power converter. Connect this pin to the input bias supply. Connect bypass capacitors between this pin and PGND.
PVIN	1	Input switching voltage. Supplies voltage to the power switches of the converter. Connect these pins to the input supply. Connect bypass capacitors between these pins and PGND.
	11	
	12	
	39	
	40	
VOUT	34	Output voltage. These pins are connected to the internal output inductor. Connect these pins to the output load and connect external bypass capacitors between these pins and PGND.
	35	
	36	
	37	
	38	
PH	41	Phase switch node. These pins must be connected to one another using a small copper island under the device for thermal relief. Do not place any external component on these pins or tie them to a pin of another function.
	10	
	13	
	14	
	15	
	16	
	17	
	18	
DNC	19	Do Not Connect. Do not connect these pins to AGND, to another DNC pin, or to any other voltage. These pins are connected to internal circuitry. Each pin must be soldered to an isolated pad.
	5	
	9	
ISHARE	24	Current share pin. Connect this pin to other LMZ31707 device's ISHARE pin when paralleling multiple LMZ31707 devices. When unused, treat this pin as a Do Not Connect (DNC) and leave it isolated from all other signals or ground.
	25	
OCP_SEL	4	Over current protection select pin. Leave this pin open for hiccup mode operation. Connect this pin to AGND for cycle-by-cycle operation. See Overcurrent Protection for more details.
ILIM	6	Current limit pin. Leave this pin open for full current limit threshold. Connect this pin to AGND to reduce the current limit threshold by approximately 3 A.
SYNC_OUT	7	Synchronization output pin. Provides a 180° out-of-phase clock signal.
PWRGD	8	Power Good flag pin. This open drain output asserts low if the output voltage is more than approximately ±6% out of regulation. A pull-up resistor is required.
RT/CLK	22	This pin is connected to an internal frequency setting resistor which sets the default switching frequency. An external resistor can be connected from this pin to AGND to increase the frequency. This pin can also be used to synchronize to an external clock.
VADJ	26	Connecting a resistor between this pin and AGND sets the output voltage.
SENSE+	27	Remote sense connection. This pin must be connected to VOUT at the load or at the device pins. Connect this pin to VOUT at the load for improved regulation.

Table 2. PIN DESCRIPTIONS (continued)

TERMINAL		DESCRIPTION
NAME	NO.	
SS/TR	28	Slow-start and tracking pin. Connecting an external capacitor to this pin adjusts the output voltage rise time. A voltage applied to this pin allows for tracking and sequencing control.
STSEL	29	Slow-start or track feature select. Connect this pin to AGND to enable the internal SS capacitor. Leave this pin open to enable the TR feature.
INH/UVLO	30	Inhibit and UVLO adjust pin. Use an open drain or open collector logic device to ground this pin to control the INH function. A resistor divider between this pin, AGND, and PVIN/VIN sets the UVLO voltage.



TYPICAL CHARACTERISTICS (P_{VIN} = V_{IN} = 12 V) (1) (2)

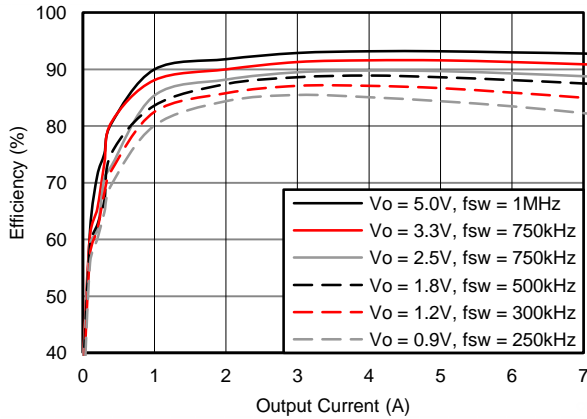

Figure 2. Efficiency vs. Output Current

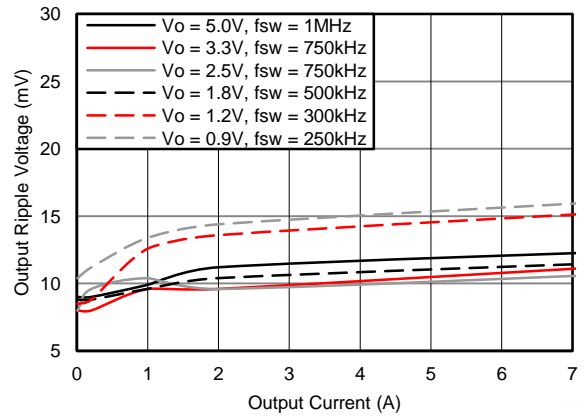

Figure 3. Voltage Ripple vs. Output Current

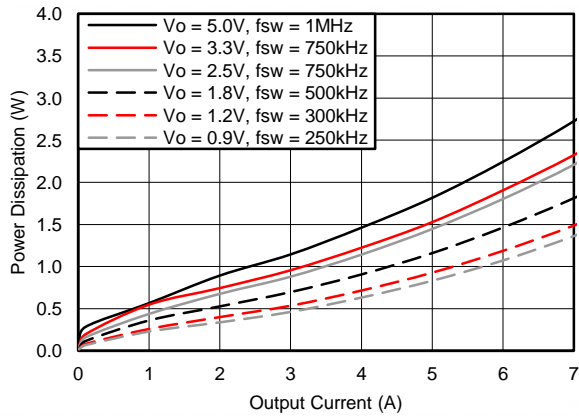

Figure 4. Power Dissipation vs. Output Current

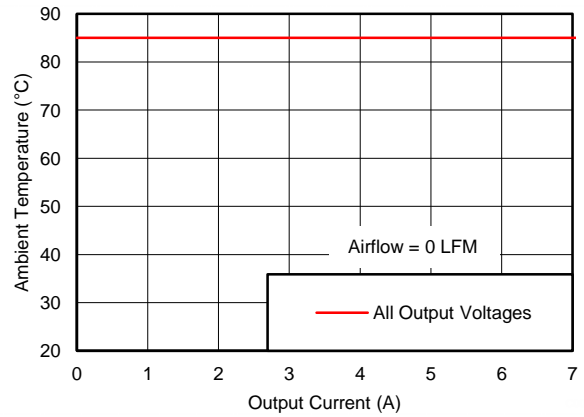

Figure 5. Safe Operating Area

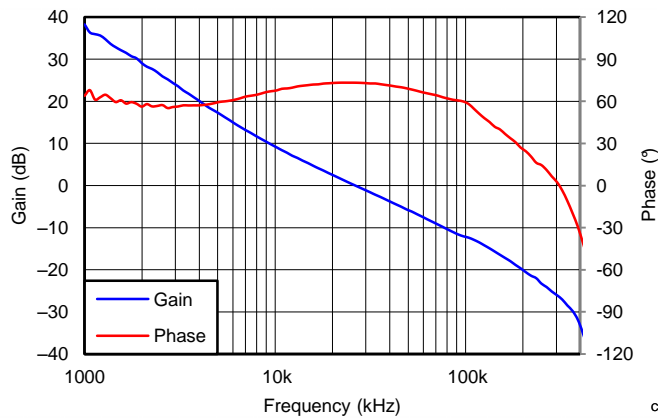

Figure 6. V_{OUT} = 1.8 V, I_{OUT} = 7 A, C_{OUT} = 200 μF ceramic, f_{SW} = 500 kHz

- (1) The electrical characteristic data has been developed from actual products tested at 25°C. This data is considered typical for the converter. Applies to [Figure 2](#), [Figure 3](#), and [Figure 4](#).
- (2) The temperature derating curves represent the conditions at which internal components are at or below the manufacturer's maximum operating temperatures. Derating limits apply to devices soldered directly to a 100 mm × 100 mm, 4-layer PCB with 2 oz. copper. Applies to [Figure 5](#).

TYPICAL CHARACTERISTICS (PVIN = VIN = 5 V) (1) (2)

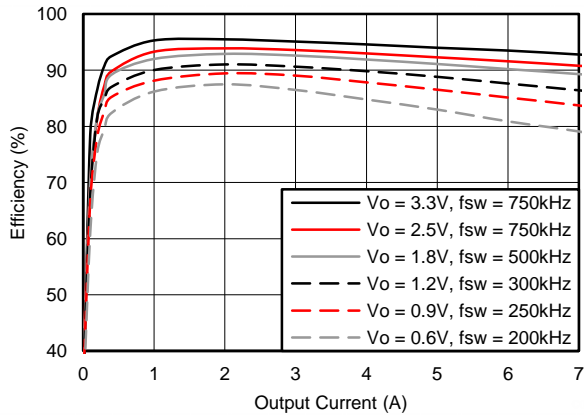

Figure 7. Efficiency vs. Output Current

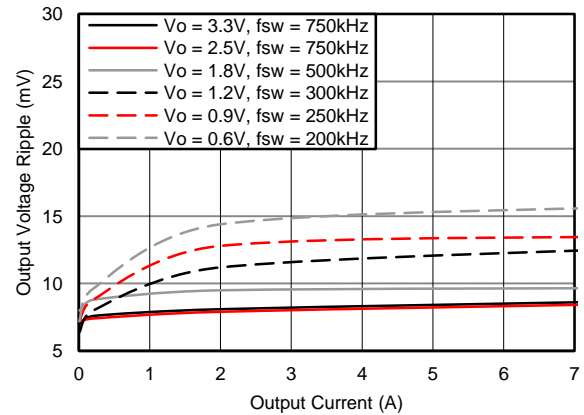

Figure 8. Voltage Ripple vs. Output Current

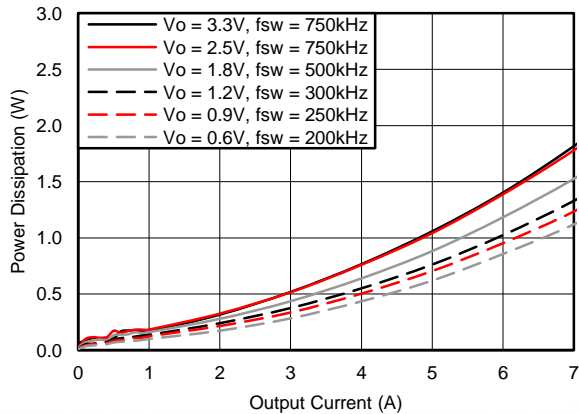

Figure 9. Power Dissipation vs. Output Current

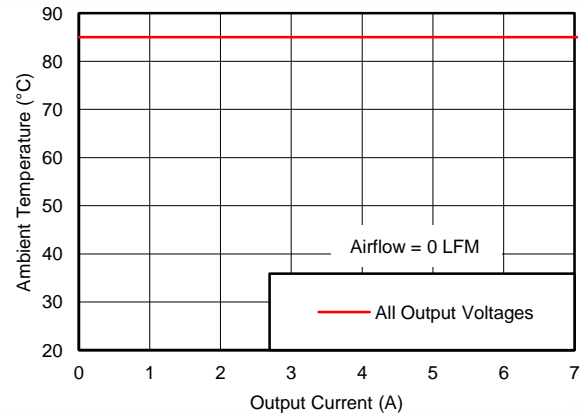

Figure 10. Safe Operating Area

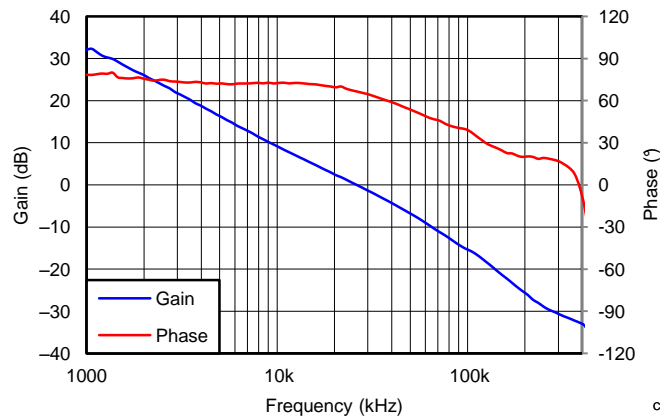

Figure 11. $V_{OUT} = 1.8\text{ V}$, $I_{OUT} = 7\text{ A}$, $C_{OUT} = 200\text{ }\mu\text{F ceramic}$, $f_{SW} = 500\text{ kHz}$

- (1) The electrical characteristic data has been developed from actual products tested at 25°C. This data is considered typical for the converter. Applies to [Figure 7](#), [Figure 8](#), and [Figure 9](#).
- (2) The temperature derating curves represent the conditions at which internal components are at or below the manufacturer's maximum operating temperatures. Derating limits apply to devices soldered directly to a 100 mm x 100 mm, 4-layer PCB with 2 oz. copper. Applies to [Figure 10](#).

TYPICAL CHARACTERISTICS (P_{VIN} = 3.3 V, V_{IN} = 5 V) ⁽¹⁾ ⁽²⁾

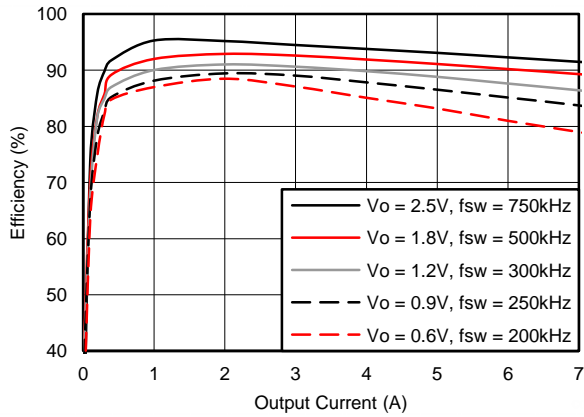

Figure 12. Efficiency vs. Output Current

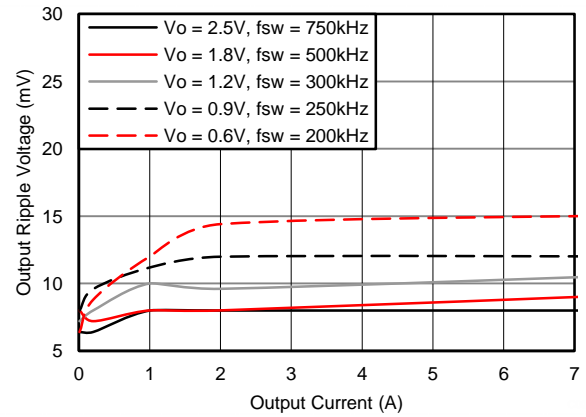

Figure 13. Voltage Ripple vs. Output Current

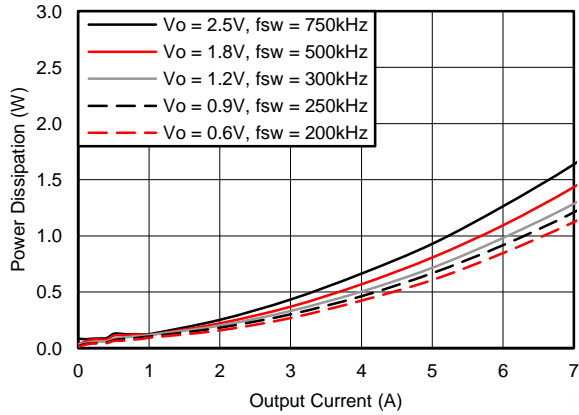

Figure 14. Power Dissipation vs. Output Current

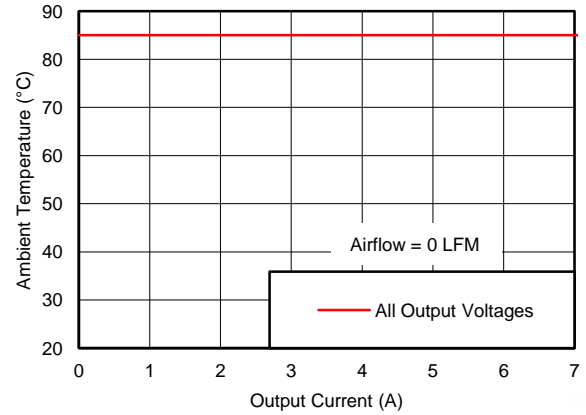

Figure 15. Safe Operating Area

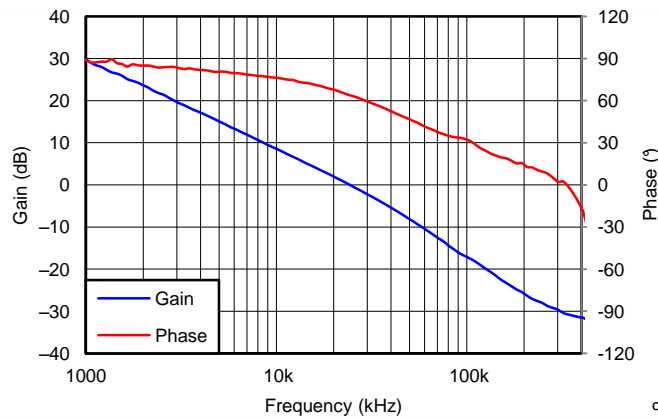

Figure 16. V_{OUT} = 1.8 V, I_{OUT} = 7 A, C_{OUT} = 200 μF ceramic, f_{SW} = 500 kHz

- (1) The electrical characteristic data has been developed from actual products tested at 25°C. This data is considered typical for the converter. Applies to [Figure 12](#), [Figure 13](#), and [Figure 14](#).
- (2) The temperature derating curves represent the conditions at which internal components are at or below the manufacturer's maximum operating temperatures. Derating limits apply to devices soldered directly to a 100 mm × 100 mm, 4-layer PCB with 2 oz. copper. Applies to [Figure 15](#).

APPLICATION INFORMATION

Adjusting the Output Voltage

The V_{ADJ} control sets the output voltage of the LMZ31707. The output voltage adjustment range is from 0.6V to 5.5V. The adjustment method requires the addition of R_{SET}, which sets the output voltage, the connection of SENSE+ to V_{OUT}, and in some cases R_{RT} which sets the switching frequency. The R_{SET} resistor must be connected directly between the V_{ADJ} (pin 26) and AGND (pin 23). The SENSE+ pin (pin 27) must be connected to V_{OUT} either at the load for improved regulation or at V_{OUT} of the device. The R_{RT} resistor must be connected directly between the RT/CLK (pin 22) and AGND (pin 23). [Table 3](#) gives the standard external R_{SET} resistor for a number of common bus voltages, along with the recommended R_{RT} resistor for that output voltage.

Table 3. Standard R_{SET} Resistor Values for Common Output Voltages

RESISTORS	OUTPUT VOLTAGE V _{OUT} (V)						
	0.9	1.0	1.2	1.8	2.5	3.3	5.0
R _{SET} (kΩ)	2.87	2.15	1.43	0.715	0.453	0.316	0.196
R _{RT} (kΩ)	1000	1000	487	169	90.9	90.9	63.4

For other output voltages, the value of the required resistor can either be calculated using the following formula, or simply selected from the range of values given in [Table 4](#).

$$R_{SET} = \frac{1.43}{\left(\left(\frac{V_{OUT}}{0.6}\right) - 1\right)} \text{ (k}\Omega\text{)} \quad (1)$$

Table 4. Standard R_{SET} Resistor Values

V _{OUT} (V)	R _{SET} (kΩ)	R _{RT} (kΩ)	f _{sw} (kHz)	V _{OUT} (V)	R _{SET} (kΩ)	R _{RT} (kΩ)	f _{sw} (kHz)
0.6	open	OPEN	200	3.1	0.348	90.9	750
0.7	8.66	OPEN	200	3.2	0.332	90.9	750
0.8	4.32	OPEN	200	3.3	0.316	90.9	750
0.9	2.87	1000	250	3.4	0.309	90.9	750
1.0	2.15	1000	250	3.5	0.294	90.9	750
1.1	1.74	1000	250	3.6	0.287	90.9	750
1.2	1.43	487	300	3.7	0.280	90.9	750
1.3	1.24	487	300	3.8	0.267	90.9	750
1.4	1.07	487	300	3.9	0.261	90.9	750
1.5	0.953	487	300	4.0	0.255	90.9	750
1.6	0.866	487	300	4.1	0.243	63.4	1000
1.7	0.787	487	300	4.2	0.237	63.4	1000
1.8	0.715	169	500	4.3	0.232	63.4	1000
1.9	0.665	169	500	4.4	0.226	63.4	1000
2.0	0.619	169	500	4.5	0.221	63.4	1000
2.1	0.576	169	500	4.6	0.215	63.4	1000
2.2	0.536	169	500	4.7	0.210	63.4	1000
2.3	0.511	169	500	4.8	0.205	63.4	1000
2.4	0.475	169	500	4.9	0.200	63.4	1000
2.5	0.453	90.9	750	5.0	0.196	63.4	1000
2.6	0.432	90.9	750	5.1	0.191	63.4	1000
2.7	0.412	90.9	750	5.2	0.187	63.4	1000
2.8	0.392	90.9	750	5.3	0.182	63.4	1000
2.9	0.374	90.9	750	5.4	0.178	63.4	1000
3.0	0.357	90.9	750	5.5	0.174	63.4	1000

Capacitor Recommendations for the LMZ31707 Power Supply

Capacitor Technologies

Electrolytic, Polymer-Electrolytic Capacitors

When using electrolytic capacitors, high-quality, computer-grade electrolytic capacitors are recommended. Polymer-electrolytic type capacitors are recommended for applications where the ambient operating temperature is less than 0°C. The Sanyo OS-CON capacitor series is suggested due to the lower ESR, higher rated surge, power dissipation, ripple current capability, and small package size. Aluminum electrolytic capacitors provide adequate decoupling over the frequency range of 2 kHz to 150 kHz, and are suitable when ambient temperatures are above 0°C.

Ceramic Capacitors

The performance of aluminum electrolytic capacitors is less effective than ceramic capacitors above 150 kHz. Multilayer ceramic capacitors have a low ESR and a resonant frequency higher than the bandwidth of the regulator. They can be used to reduce the reflected ripple current at the input as well as improve the transient response of the output.

Tantalum, Polymer-Tantalum Capacitors

Polymer-tantalum type capacitors are recommended for applications where the ambient operating temperature is less than 0°C. The Sanyo POSCAP series and Kemet T530 capacitor series are recommended rather than many other tantalum types due to their lower ESR, higher rated surge, power dissipation, ripple current capability, and small package size. Tantalum capacitors that have no stated ESR or surge current rating are not recommended for power applications.

Input Capacitor

The LMZ31707 requires a minimum input capacitance of 44 μF of ceramic type. An additional 100 μF of non-ceramic capacitance is recommended for applications with transient load requirements. The voltage rating of input capacitors must be greater than the maximum input voltage. At worst case, when operating at 50% duty cycle and maximum load, the combined ripple current rating of the input capacitors must be at least 3.5 Arms. [Table 6](#) includes a preferred list of capacitors by vendor. It is also recommended to place a 0.1 μF ceramic capacitor directly across the PVIN and PGND pins of the device. When operating with split VIN and PVIN rails, place 4.7 μF of ceramic capacitance directly at the VIN pin.

Output Capacitor

The required output capacitance is determined by the output voltage of the LMZ31707. See [Table 5](#) for the amount of required capacitance. The effects of temperature and capacitor voltage rating must be considered when selecting capacitors to meet the minimum required capacitance. The required output capacitance can be comprised of all ceramic capacitors, or a combination of ceramic and bulk capacitors. The required capacitance must include at least one 47 μF ceramic. When adding additional non-ceramic bulk capacitors, low-ESR devices like the ones recommended in [Table 6](#) are required. The required capacitance above the minimum is determined by actual transient deviation requirements. [Table 6](#) includes a preferred list of capacitors by vendor.

Table 5. Required Output Capacitance

V _{OUT} RANGE (V)		MINIMUM REQUIRED C _{OUT} (μF)
MIN	MAX	
0.6	< 0.8	500 μF ⁽¹⁾
0.8	< 1.2	300 μF ⁽¹⁾
1.2	< 3.0	200 μF ⁽¹⁾
3.0	< 4.0	100 μF ⁽¹⁾
4.0	5.5	47 μF ceramic

(1) Minimum required must include at least one 47 μF ceramic capacitor.

Table 6. Recommended Input/Output Capacitors⁽¹⁾

VENDOR	SERIES	PART NUMBER	CAPACITOR CHARACTERISTICS		
			WORKING VOLTAGE (V)	CAPACITANCE (μF)	ESR ⁽²⁾ (mΩ)
Murata	X5R	GRM32ER61E226K	25	22	2
TDK	X5R	C3225X5R0J107M	6.3	100	2
TDK	X5R	C3225X5R0J476K	6.3	47	2
Murata	X5R	GRM32ER60J107M	6.3	100	2
Murata	X5R	GRM32ER60J476M	6.3	47	2
Panasonic	EEH-ZA	EEH-ZA1E101XP	25	100	30
Sanyo	POSCAP	16TQC68M	16	68	50
Kemet	T520	T520V107M010ASE025	10	100	25
Sanyo	POSCAP	10TPE220ML	10	220	25
Sanyo	POSCAP	6TPE100MI	6.3	100	25
Sanyo	POSCAP	2R5TPE220M7	2.5	220	7
Kemet	T530	T530D227M006ATE006	6.3	220	6
Kemet	T530	T530D337M006ATE010	6.3	330	10
Sanyo	POSCAP	2TPF330M6	2.0	330	6
Sanyo	POSCAP	6TPE330MFL	6.3	330	15

(1) Capacitor Supplier Verification, RoHS, Lead-free and Material Details

Consult capacitor suppliers regarding availability, material composition, RoHS and lead-free status, and manufacturing process requirements for any capacitors identified in this table.

(2) Maximum ESR @ 100kHz, 25°C.
Transient Response
Table 7. Output Voltage Transient Response

C _{IN1} = 3x 22 μF CERAMIC, C _{IN2} = 100 μF POLYMER-TANTALUM						
V _{OUT} (V)	V _{IN} (V)	C _{OUT1} Ceramic	C _{OUT2} BULK	VOLTAGE DEVIATION (mV)		RECOVERY TIME (μs)
				2 A LOAD STEP, (1 A/μs)	3.5 A LOAD STEP, (1 A/μs)	
0.6	5	500 μF	220 μF	30	45	90
	12	500 μF	220 μF	30	45	90
0.9	5	300 μF	220 μF	40	65	95
		300 μF	470 μF	35	60	95
	12	300 μF	220 μF	35	60	95
		300 μF	470 μF	30	55	95
1.2	5	200 μF	220 μF	50	85	100
		200 μF	470 μF	45	75	100
	12	200 μF	220 μF	45	80	100
		200 μF	470 μF	40	70	100
1.8	5	200 μF	220 μF	70	105	110
		200 μF	470 μF	65	90	110
	12	200 μF	220 μF	65	100	120
		200 μF	470 μF	60	90	120
3.3	5	100 μF	220 μF	105	177	130
	12	100 μF	220 μF	115	190	150

Transient Waveforms

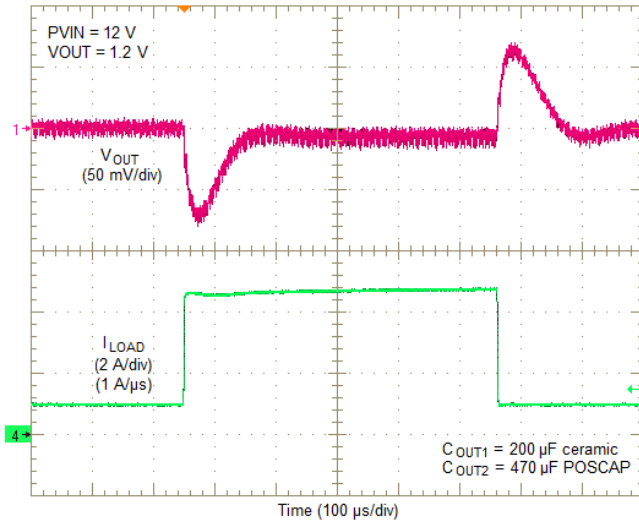

Figure 17. PVIN = 12V, VOUT = 1.2V, 3.5A Load Step

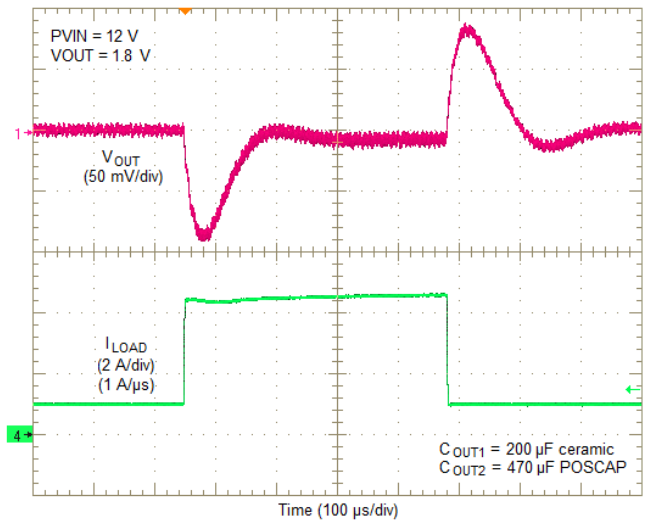

Figure 18. PVIN = 12V, VOUT = 1.8V, 3.5A Load Step

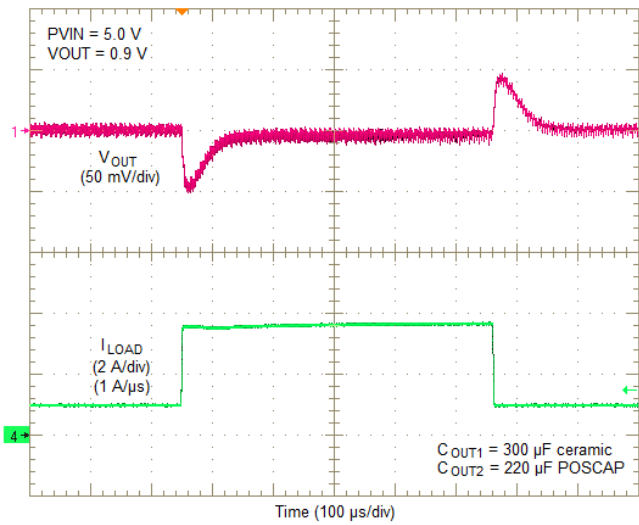

Figure 19. PVIN = 5V, VOUT = 0.9V, 2.5A Load Step

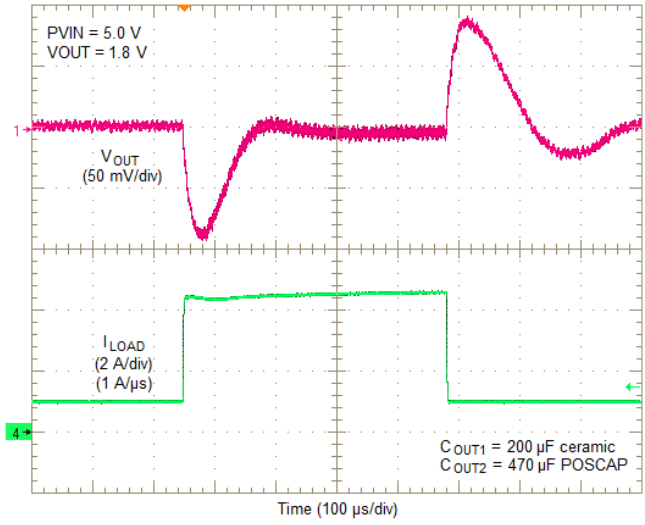

Figure 20. PVIN = 5V, VOUT = 1.8V, 3.5A Load Step

Application Schematics

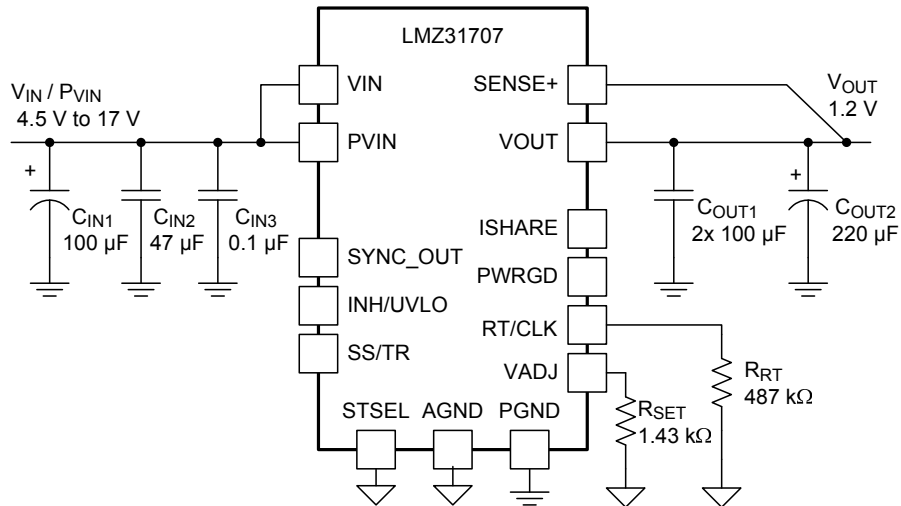

Figure 21. Typical Schematic
PVIN = VIN = 4.5 V to 17 V, VOUT = 1.2 V

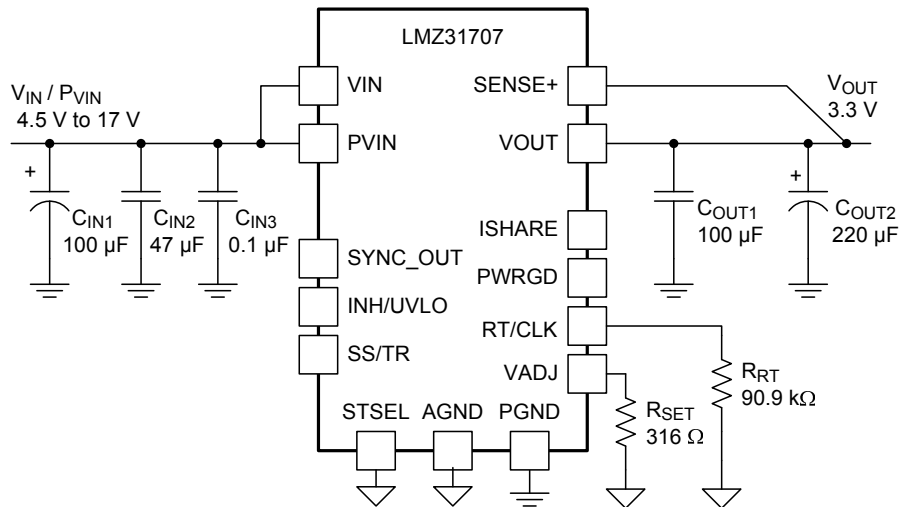

Figure 22. Typical Schematic
PVIN = VIN = 4.5 V to 17 V, VOUT = 3.3 V

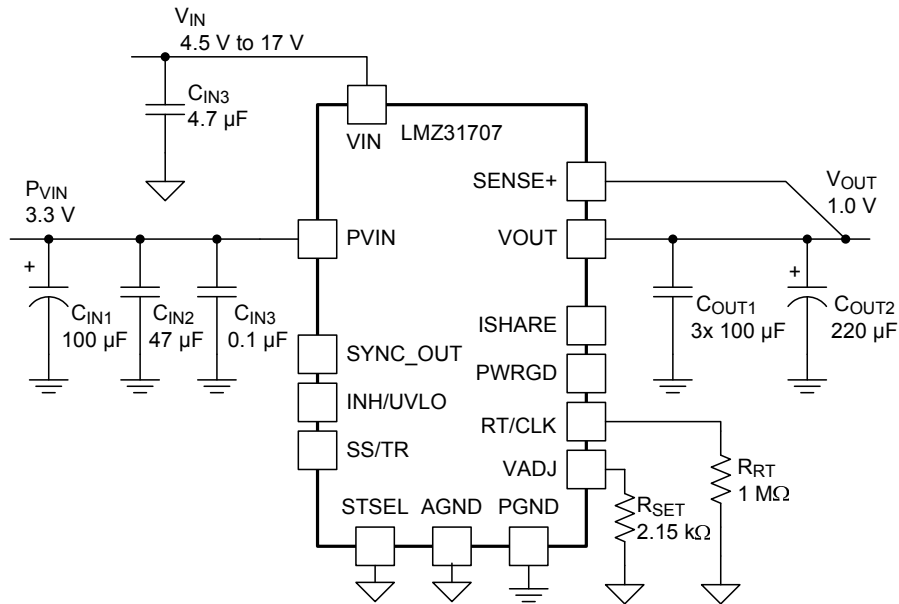

Figure 23. Typical Schematic
PVIN = 3.3 V, VIN = 4.5 V to 17 V, VOUT = 1.0 V

VIN and PVIN Input Voltage

The LMZ31707 allows for a variety of applications by using the VIN and PVIN pins together or separately. The VIN voltage supplies the internal control circuits of the device. The PVIN voltage provides the input voltage to the power converter system.

If tied together, the input voltage for the VIN pin and the PVIN pin can range from 4.5 V to 17 V. If using the VIN pin separately from the PVIN pin, the VIN pin must be greater than 4.5 V, and the PVIN pin can range from as low as 2.95 V to 17 V. When operating from a split rail, it is recommended to supply VIN from 5 V to 12 V, for best performance. A voltage divider connected to the INH/UVLO pin can adjust either input voltage UVLO appropriately. See the [Programmable Undervoltage Lockout \(UVLO\)](#) section of this datasheet for more information.

3.3 V PVIN Operation

Applications operating from a PVIN of 3.3 V must provide at least 4.5 V for VIN. It is recommended to supply VIN from 5 V to 12 V, for best performance. See listeraure number [SNVA692](#) for help creating 5 V from 3.3 V using a small, simple charge pump device.

Power Good (PWRGD)

The PWRGD pin is an open drain output. Once the voltage on the SENSE+ pin is between 95% and 104% of the set voltage, the PWRGD pin pull-down is released and the pin floats. The recommended pull-up resistor value is between 10 kΩ and 100 kΩ to a voltage source that is 5.5 V or less. The PWRGD pin is in a defined state once VIN is greater than 1.0 V, but with reduced current sinking capability. The PWRGD pin achieves full current sinking capability once the VIN pin is above 4.5V. The PWRGD pin is pulled low when the voltage on SENSE+ is lower than 91% or greater than 108% of the nominal set voltage. Also, the PWRGD pin is pulled low if the input UVLO or thermal shutdown is asserted, the INH pin is pulled low, or the SS/TR pin is below 1.4 V.

SYNC_OUT

The LMZ31707 provides a 180° out-of-phase clock signal for applications requiring synchronization. The SYNC_OUT pin produces a 50% duty cycle clock signal that is the same frequency as the device's switching frequency, but is 180° out of phase. Operating two devices 180° out of phase reduces input and output voltage ripple. The SYNC_OUT clock signal is compatible with other LMZ3 devices that have a CLK input.

Parallel Operation

Up to six LMZ31707 devices can be paralleled for increased output current. Multiple connections must be made between the paralleled devices and the component selection is slightly different than for a stand-alone LMZ31707 device. A typical LMZ31707 parallel schematic is shown in Figure 24. Refer to application note, [SNVA695](#) for information and design help when paralleling multiple LMZ31707 devices.

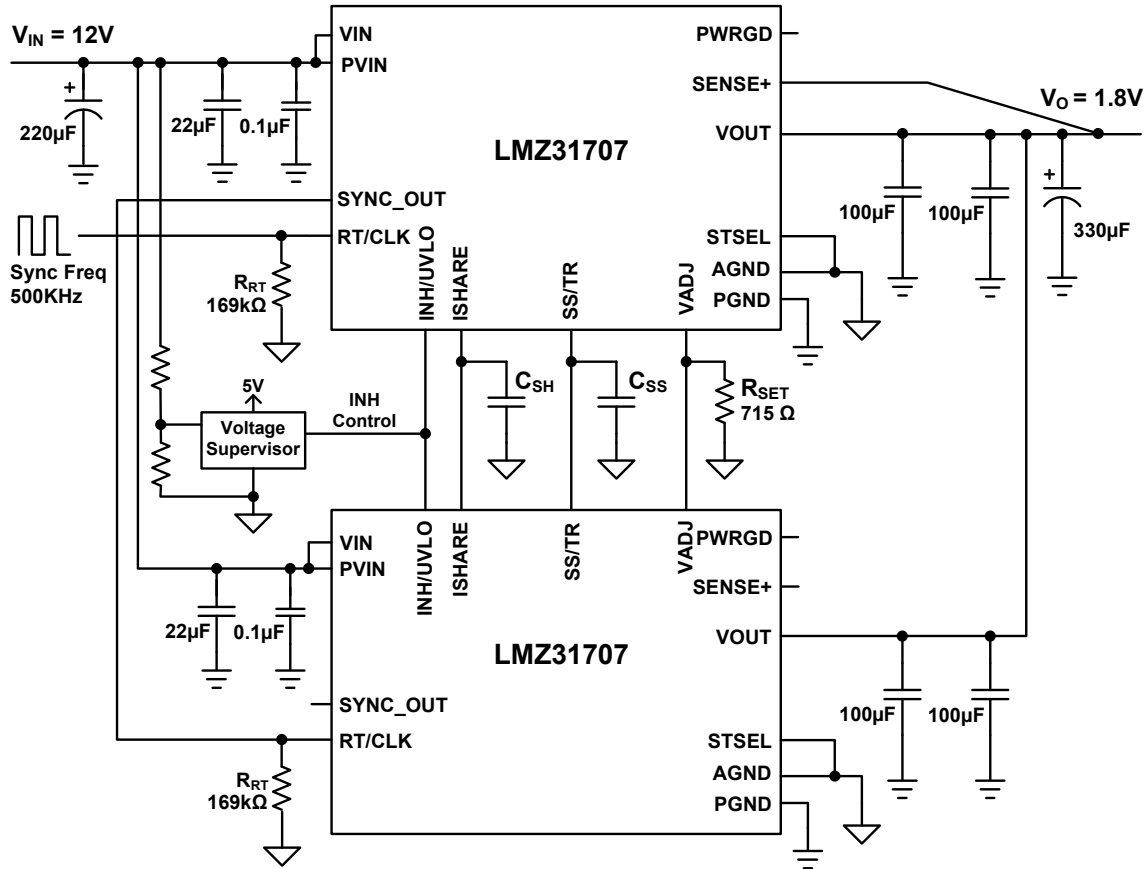

Figure 24. Typical LMZ31707 Parallel Schematic

Light Load Efficiency (LLE)

The LMZ31707 operates in pulse skip mode at light load currents to improve efficiency and decrease power dissipation by reducing switching and gate drive losses.

These pulses may cause the output voltage to rise when there is no load to discharge the energy. For output voltages < 1.5 V, a minimum load is required. The amount of required load can be determined by Equation 2. In most cases the minimum current drawn by the load circuit will be enough to satisfy this load. Applications requiring a load resistor to meet the minimum load, the added power dissipation will be ≤ 3.6 mW. A single 0402 size resistor across VOUT and PGND can be used.

$$I_{\text{MIN}} = 600 \mu\text{A} - \left(\frac{V_{\text{OUT}}}{1.43\text{k} + R_{\text{SET}}} \right) \text{ (A)} \quad (2)$$

When $V_{\text{OUT}} = 0.6 \text{ V}$ and $R_{\text{SET}} = \text{OPEN}$, the minimum load current is 600 μA .

Power-Up Characteristics

When configured as shown in the front page schematic, the LMZ31707 produces a regulated output voltage following the application of a valid input voltage. During the power-up, internal soft-start circuitry slows the rate that the output voltage rises, thereby limiting the amount of in-rush current that can be drawn from the input source. Figure 25 shows the start-up waveforms for a LMZ31707, operating from a 5-V input ($P_{VIN}=VIN$) and with the output voltage adjusted to 1.8 V. Figure 26 shows the start-up waveforms for a LMZ31707 starting up into a pre-biased output voltage. The waveforms were measured with a 5-A constant current load.

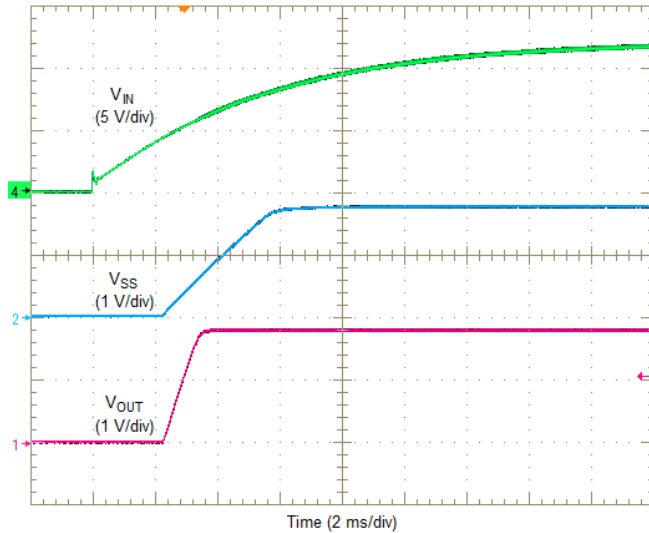

Figure 25. Start-Up Waveforms

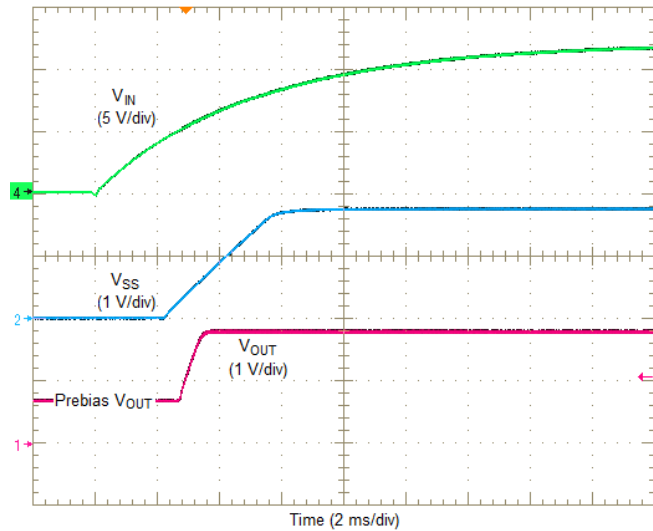

Figure 26. Start-up into Pre-bias

Pre-Biased Start-Up

The LMZ31707 has been designed to prevent the low-side MOSFET from discharging a pre-biased output. During pre-biased startup, the low-side MOSFET does not turn on until the high-side MOSFET has started switching. The high-side MOSFET does not start switching until the slow start voltage exceeds the voltage on the VADJ pin. Refer to Figure 26.

Remote Sense

The SENSE+ pin must be connected to V_{OUT} at the load, or at the device pins.

Connecting the SENSE+ pin to V_{OUT} at the load improves the load regulation performance of the device by allowing it to compensate for any I-R voltage drop between its output pins and the load. An I-R drop is caused by the high output current flowing through the small amount of pin and trace resistance. This should be limited to a maximum of 300 mV.

NOTE

The remote sense feature is not designed to compensate for the forward drop of nonlinear or frequency dependent components that may be placed in series with the converter output. Examples include OR-ing diodes, filter inductors, ferrite beads, and fuses. When these components are enclosed by the SENSE+ connection, they are effectively placed inside the regulation control loop, which can adversely affect the stability of the regulator.

Thermal Shutdown

The internal thermal shutdown circuitry forces the device to stop switching if the junction temperature exceeds 175°C typically. The device reinitiates the power up sequence when the junction temperature drops below 165°C typically.

Output On/Off Inhibit (INH)

The INH pin provides electrical on/off control of the device. Once the INH pin voltage exceeds the threshold voltage, the device starts operation. If the INH pin voltage is pulled below the threshold voltage, the regulator stops switching and enters low quiescent current state. The INH pin has an internal pull-up current source, allowing the user to float the INH pin for enabling the device.

If an application requires controlling the INH pin, use an open drain/collector device, or a suitable logic gate to interface with the pin. Using a voltage supervisor to control the INH pin allows control of the turn-on and turn-off of the device as opposed to relying on the ramp up or down if the input voltage source.

Figure 27 shows the typical application of the inhibit function. Turning Q1 on applies a low voltage to the inhibit control (INH) pin and disables the output of the supply, shown in Figure 28. If Q1 is turned off, the supply executes a soft-start power-up sequence, as shown in Figure 29. A regulated output voltage is produced within 2 ms. The waveforms were measured with a 5-A constant current load.

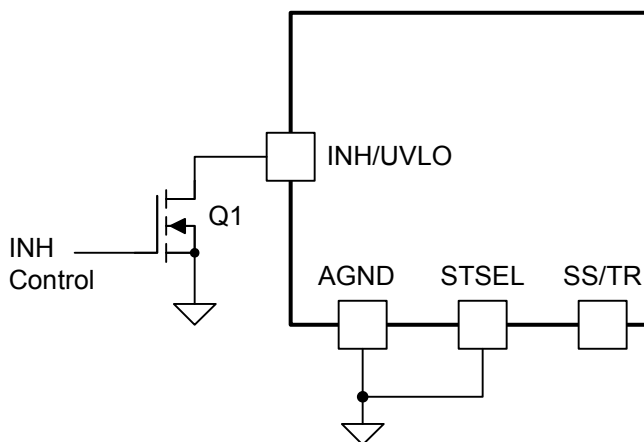

Figure 27. Typical Inhibit Control

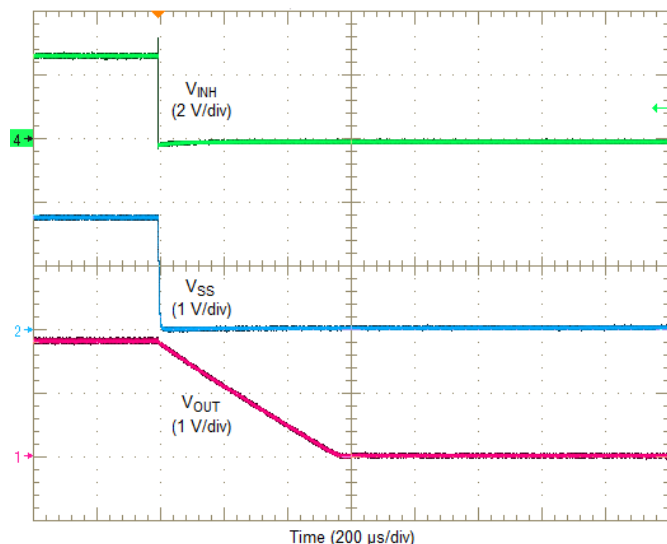

Figure 28. Inhibit Turn-Off

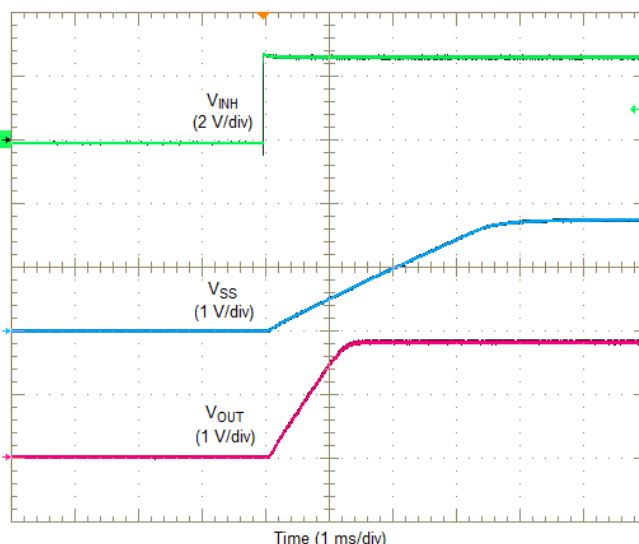

Figure 29. Inhibit Turn-On

Slow Start (SS/TR)

Connecting the STSEL pin to AGND and leaving SS/TR pin open enables the internal SS capacitor with a slow start interval of approximately 1.2 ms. Adding additional capacitance between the SS pin and AGND increases the slow start time. Increasing the slow start time will reduce inrush current seen by the input source and reduce the current seen by the device when charging the output capacitors. To avoid the activation of current limit and ensure proper start-up, the SS capacitor may need to be increased when operating near the maximum output capacitance limit.

Figure 30 shows an additional SS capacitor connected to the SS/TR pin and the STSEL pin connected to AGND. See Table 8 below for SS capacitor values and timing interval.

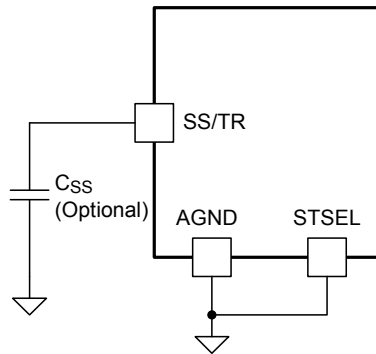

Figure 30. Slow-Start Capacitor (C_{SS}) and STSEL Connection

Table 8. Slow-Start Capacitor Values and Slow-Start Time

C _{SS} (nF)	open	3.3	4.7	10	15	22	33
SS Time (msec)	1.2	2.1	2.5	3.8	5.1	7.0	9.8

Overcurrent Protection

For protection against load faults, the LMZ31707 incorporates output overcurrent protection. The overcurrent protection mode can be selected using the OCP_SEL pin. Leaving the OCP_SEL pin open selects hiccup mode and connecting it to AGND selects cycle-by-cycle mode. In hiccup mode, applying a load that exceeds the regulator's overcurrent threshold causes the regulated output to shut down. Following shutdown, the module periodically attempts to recover by initiating a soft-start power-up as shown in Figure 31. This is described as a hiccup mode of operation, whereby the module continues in a cycle of successive shutdown and power up until the load fault is removed. During this period, the average current flowing into the fault is significantly reduced which reduces power dissipation. Once the fault is removed, the module automatically recovers and returns to normal operation as shown in Figure 32.

In cycle-by-cycle mode, applying a load that exceeds the regulator's overcurrent threshold limits the output current and reduces the output voltage as shown in Figure 33. During this period, the current flowing into the fault remains high causing the power dissipation to stay high as well. Once the overcurrent condition is removed, the output voltage returns to the set-point voltage as shown in Figure 34.

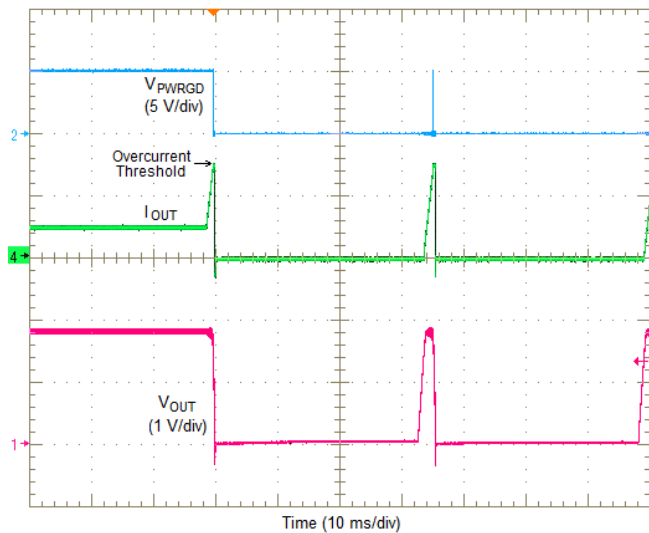

Figure 31. Overcurrent Limiting (Hiccup)

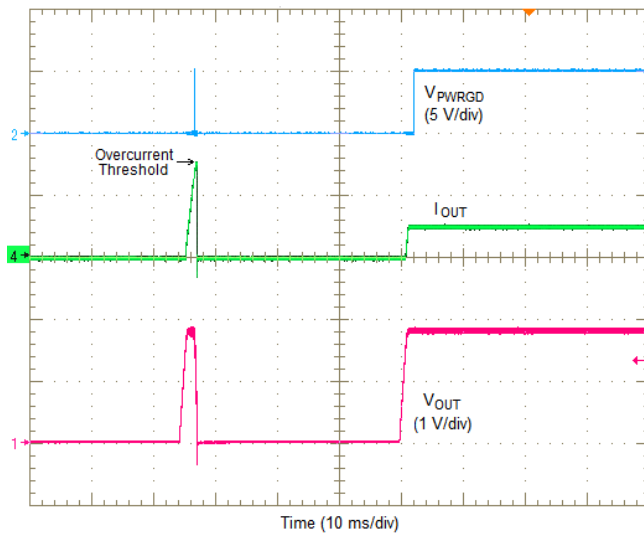

Figure 32. Removal of Overcurrent (Hiccup)

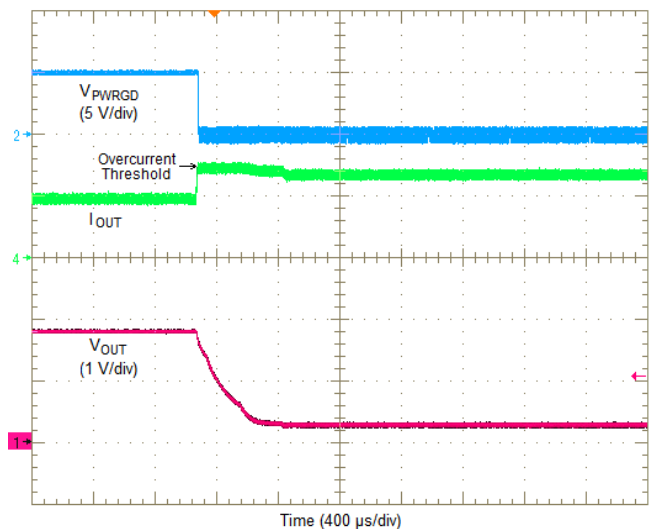

Figure 33. Overcurrent Limiting (Cycle-by-Cycle)

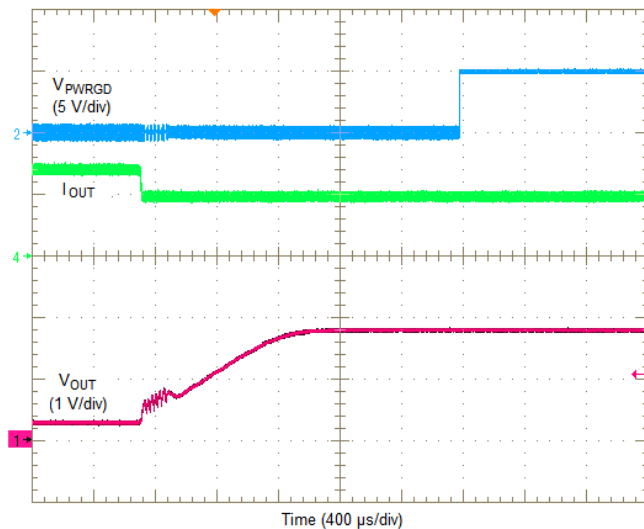

Figure 34. Removal of Overcurrent (Cycle-by-Cycle)

Synchronization (CLK)

An internal phase locked loop (PLL) has been implemented to allow synchronization between 200 kHz and 1200 kHz, and to easily switch from RT mode to CLK mode. To implement the synchronization feature, connect a square wave clock signal to the RT/CLK pin with a duty cycle between 20% to 80%. The clock signal amplitude must transition lower than 0.5 V and higher than 2.0 V. The start of the switching cycle is synchronized to the falling edge of RT/CLK pin. In applications where both RT mode and CLK mode are needed, the device can be configured as shown in [Figure 35](#).

Before the external clock is present, the device works in RT mode and the switching frequency is set by RT resistor. When the external clock is present, the CLK mode overrides the RT mode. The first time the CLK pin is pulled above the RT/CLK high threshold (2.0 V), the device switches from RT mode to CLK mode and the RT/CLK pin becomes high impedance as the PLL starts to lock onto the frequency of the external clock. It is not recommended to switch from CLK mode back to RT mode because the internal switching frequency drops to 100 kHz first before returning to the switching frequency set by the RT resistor (R_{RT}).

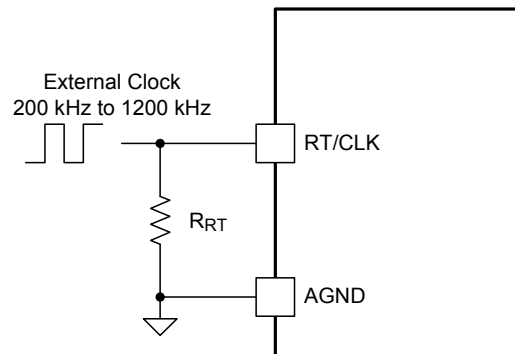

Figure 35. RT/CLK Configuration

The synchronization frequency must be selected based on the output voltages of the devices being synchronized. [Table 9](#) shows the allowable frequencies for a given range of output voltages. For the most efficient solution, always synchronize to the lowest allowable frequency. For example, an application requires synchronizing three LMZ31707 devices with output voltages of 1.0 V, 1.2 V and 1.8 V, all powered from $P_{VIN} = 12$ V. [Table 9](#) shows that all three output voltages should be synchronized to 300 kHz.

Table 9. Synchronization Frequency vs Output Voltage

SYNCHRONIZATION FREQUENCY (kHz)	$P_{VIN} = 12$ V		$P_{VIN} = 5$ V	
	V_{OUT} RANGE (V)		V_{OUT} RANGE (V)	
	MIN	MAX	MIN	MAX
200	0.6	1.3	0.6	1.5
300	0.8	2.0	0.6	4.3
400	1.1	2.5	0.6	4.3
500	1.4	3.4	0.6	4.3
600	1.6	5.0	0.7	4.3
700	1.9	5.5	0.8	4.3
800	2.1	5.5	0.9	4.3
900	2.4	5.5	1.0	4.3
1000	2.7	5.5	1.1	4.3
1100	2.9	5.5	1.3	4.3
1200	3.2	5.5	1.4	4.3

Sequencing (SS/TR)

Many of the common power supply sequencing methods can be implemented using the SS/TR, INH and PWRGD pins. The sequential method is illustrated in Figure 36 using two LMZ31707 devices. The PWRGD pin of the first device is coupled to the INH pin of the second device which enables the second power supply once the primary supply reaches regulation. Figure 37 shows sequential turn-on waveforms of two LMZ31707 devices.

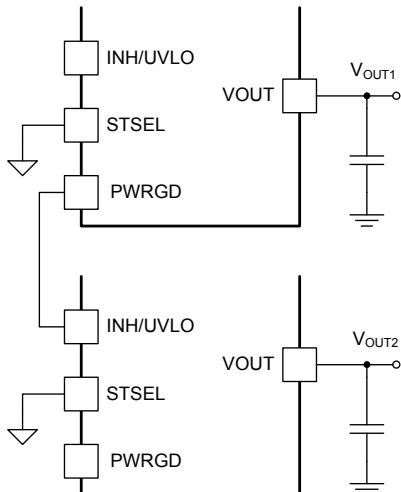

Figure 36. Sequencing Schematic

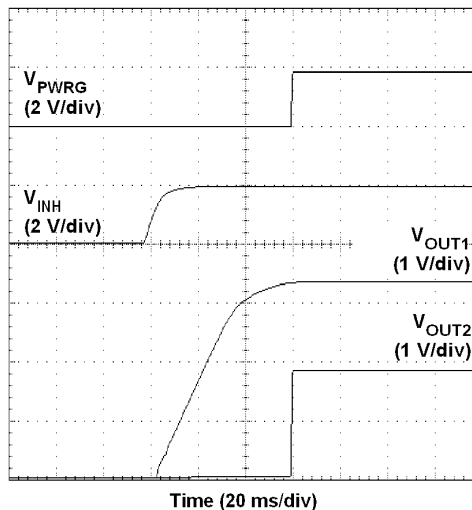

Figure 37. Sequencing Waveforms

Simultaneous power supply sequencing can be implemented by connecting the resistor network of R1 and R2 shown in Figure 38 to the output of the power supply that needs to be tracked or to another voltage reference source. The tracking voltage must exceed 750mV before V_{OUT2} reaches its set-point voltage. The PWRGD output of the V_{OUT2} device may remain low if the tracking voltage does not exceed 1.4V. Figure 39 shows simultaneous turn-on waveforms of two LMZ31707 devices. Use Equation 3 and Equation 4 to calculate the values of R1 and R2.

$$R1 = \frac{(V_{OUT2} \times 12.6)}{0.6} \text{ (k}\Omega\text{)} \tag{3}$$

$$R2 = \frac{0.6 \times R1}{(V_{OUT2} - 0.6)} \text{ (k}\Omega\text{)} \tag{4}$$

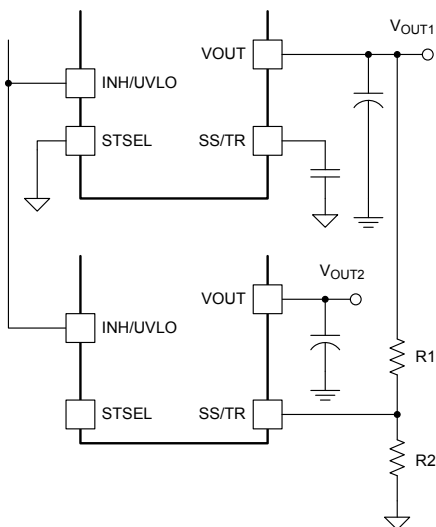

Figure 38. Simultaneous Tracking Schematic

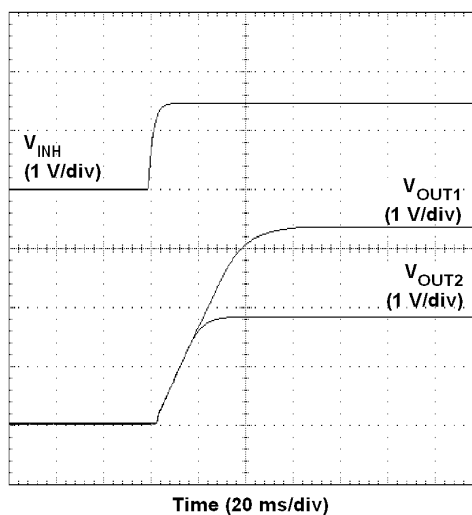

Figure 39. Simultaneous Tracking Waveforms

Programmable Undervoltage Lockout (UVLO)

The LMZ31707 implements internal UVLO circuitry on the VIN pin. The device is disabled when the VIN pin voltage falls below the internal VIN UVLO threshold. The internal VIN UVLO rising threshold is 4.5 V(max) with a typical hysteresis of 150 mV.

If an application requires either a higher UVLO threshold on the VIN pin or a higher UVLO threshold for a combined VIN and PVIN, then the UVLO pin can be configured as shown in [Figure 40](#) or [Figure 41](#). [Table 10](#) lists standard values for R_{UVLO1} and R_{UVLO2} to adjust the VIN UVLO voltage up.

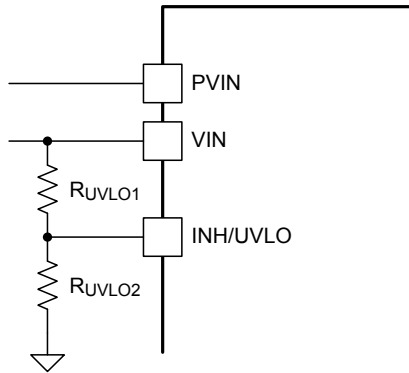

Figure 40. Adjustable VIN UVLO

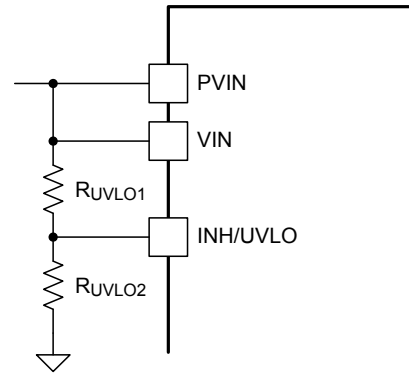

Figure 41. Adjustable VIN and PVIN Undervoltage Lockout

Table 10. Standard Resistor values for Adjusting VIN UVLO

VIN UVLO (V)	5.0	5.5	6.0	6.5	7.0	7.5	8.0	8.5	9.0	9.5	10.0
R_{UVLO1} (k Ω)	68.1	68.1	68.1	68.1	68.1	68.1	68.1	68.1	68.1	68.1	68.1
R_{UVLO2} (k Ω)	21.5	18.7	16.9	15.4	14.0	13.0	12.1	11.3	10.5	9.76	9.31
Hysteresis (mV)	400	415	430	450	465	480	500	515	530	550	565

For a split rail application, if a secondary UVLO on PVIN is required, VIN must be $\geq 4.5V$. [Figure 42](#) shows the PVIN UVLO configuration. Use [Table 11](#) to select R_{UVLO1} and R_{UVLO2} for PVIN. If PVIN UVLO is set for less than 3.0 V, a 5.1-V zener diode should be added to clamp the voltage on the UVLO pin below 6 V.

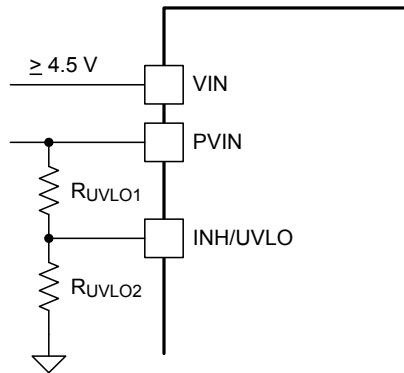

Figure 42. Adjustable PVIN Undervoltage Lockout, (VIN ≥ 4.5 V)

Table 11. Standard Resistor Values for Adjusting PVIN UVLO, (VIN ≥ 4.5 V)

PVIN UVLO (V)	2.9	3.0	3.5	4.0	4.5	
R_{UVLO1} (k Ω)	68.1	68.1	68.1	68.1	68.1	For higher PVIN UVLO voltages see Table 10 for resistor values
R_{UVLO2} (k Ω)	47.5	44.2	34.8	28.7	24.3	
Hysteresis (mV)	330	335	350	365	385	

Layout Considerations

To achieve optimal electrical and thermal performance, an optimized PCB layout is required. Figure 43 thru Figure 46, shows a typical PCB layout. Some considerations for an optimized layout are:

- Use large copper areas for power planes (PVIN, VOUT, and PGND) to minimize conduction loss and thermal stress.
- Place ceramic input and output capacitors close to the device pins to minimize high frequency noise.
- Locate additional output capacitors between the ceramic capacitor and the load.
- Keep AGND and PGND separate from one another.
- Place R_{SET} , R_{RT} , and C_{SS} as close as possible to their respective pins.
- Use multiple vias to connect the power planes to internal layers.

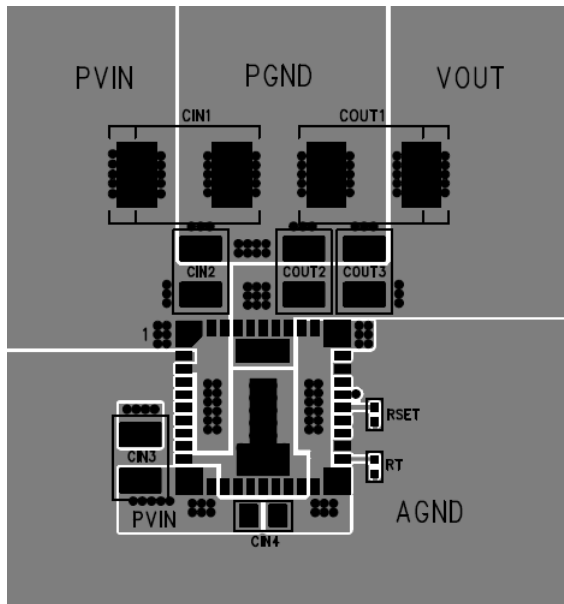

Figure 43. Typical Top-Layer Layout

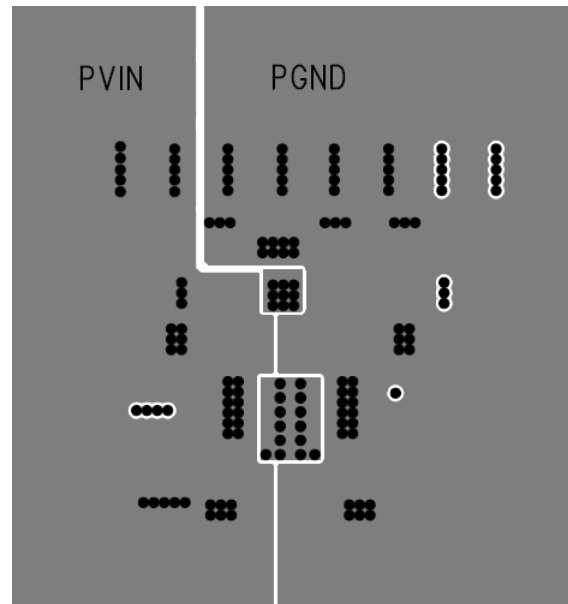

Figure 44. Typical Layer-2 Layout

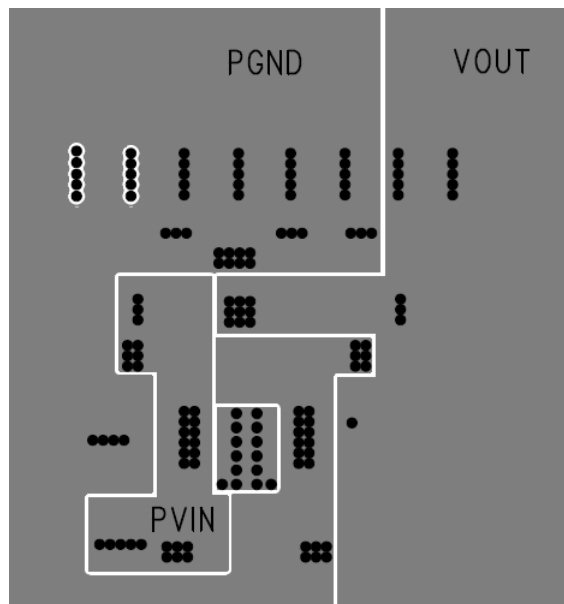

Figure 45. Typical Layer-3 Layout

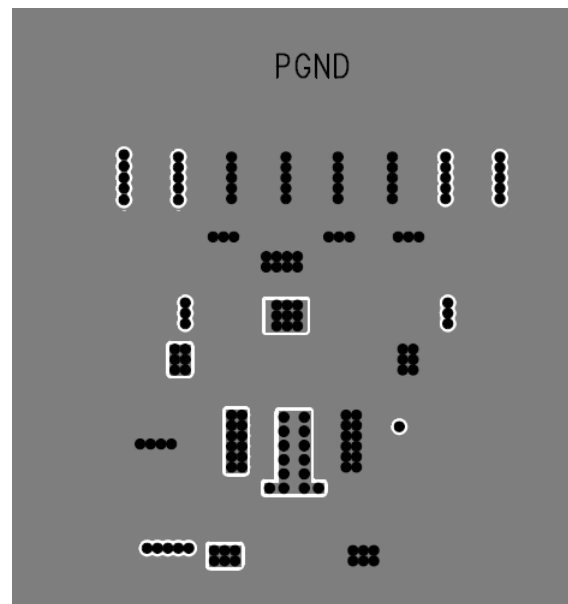

Figure 46. Typical Bottom-Layer Layout

EMI

The LMZ31707 is compliant with EN55022 Class B radiated emissions. [Figure 47](#) and [Figure 48](#) show typical examples of radiated emissions plots for the LMZ31707 operating from 5V and 12V respectively. Both graphs include the plots of the antenna in the horizontal and vertical positions.

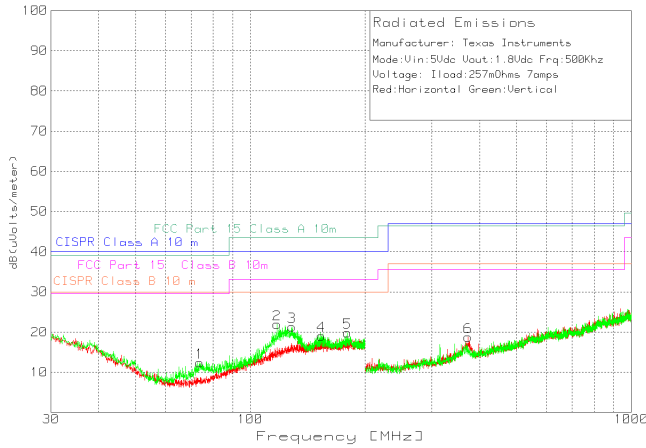

Figure 47. Radiated Emissions 5-V Input, 1.8-V Output, 7-A Load (EN55022 Class B)

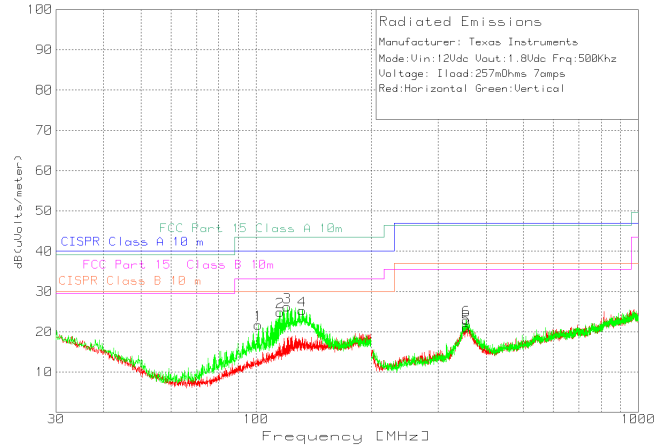

Figure 48. Radiated Emissions 12-V Input, 1.8-V Output, 7-A Load (EN55022 Class B)

PACKAGING INFORMATION

Orderable Device	Status (1)	Package Type	Package Drawing	Pins	Package Qty	Eco Plan (2)	Lead/Ball Finish (6)	MSL Peak Temp (3)	Op Temp (°C)	Device Marking (4/5)	Samples
LMZ31707RVQR	ACTIVE	B3QFN	RVQ	42	500	Green (RoHS & no Sb/Br)	CU NIPDAU	Level-3-260C-168 HR	-40 to 85	(54020 ~ LMZ31707)	Samples
LMZ31707RVQT	ACTIVE	B3QFN	RVQ	42	250	Green (RoHS & no Sb/Br)	CU NIPDAU	Level-3-260C-168 HR	-40 to 85	(54020 ~ LMZ31707)	Samples

(1) The marketing status values are defined as follows:

ACTIVE: Product device recommended for new designs.

LIFEBUY: TI has announced that the device will be discontinued, and a lifetime-buy period is in effect.

NRND: Not recommended for new designs. Device is in production to support existing customers, but TI does not recommend using this part in a new design.

PREVIEW: Device has been announced but is not in production. Samples may or may not be available.

OBsolete: TI has discontinued the production of the device.

(2) Eco Plan - The planned eco-friendly classification: Pb-Free (RoHS), Pb-Free (RoHS Exempt), or Green (RoHS & no Sb/Br) - please check <http://www.ti.com/productcontent> for the latest availability information and additional product content details.

TBD: The Pb-Free/Green conversion plan has not been defined.

Pb-Free (RoHS): TI's terms "Lead-Free" or "Pb-Free" mean semiconductor products that are compatible with the current RoHS requirements for all 6 substances, including the requirement that lead not exceed 0.1% by weight in homogeneous materials. Where designed to be soldered at high temperatures, TI Pb-Free products are suitable for use in specified lead-free processes.

Pb-Free (RoHS Exempt): This component has a RoHS exemption for either 1) lead-based flip-chip solder bumps used between the die and package, or 2) lead-based die adhesive used between the die and leadframe. The component is otherwise considered Pb-Free (RoHS compatible) as defined above.

Green (RoHS & no Sb/Br): TI defines "Green" to mean Pb-Free (RoHS compatible), and free of Bromine (Br) and Antimony (Sb) based flame retardants (Br or Sb do not exceed 0.1% by weight in homogeneous material)

(3) MSL, Peak Temp. - The Moisture Sensitivity Level rating according to the JEDEC industry standard classifications, and peak solder temperature.

(4) There may be additional marking, which relates to the logo, the lot trace code information, or the environmental category on the device.

(5) Multiple Device Markings will be inside parentheses. Only one Device Marking contained in parentheses and separated by a "~" will appear on a device. If a line is indented then it is a continuation of the previous line and the two combined represent the entire Device Marking for that device.

(6) Lead/Ball Finish - Orderable Devices may have multiple material finish options. Finish options are separated by a vertical ruled line. Lead/Ball Finish values may wrap to two lines if the finish value exceeds the maximum column width.

Important Information and Disclaimer: The information provided on this page represents TI's knowledge and belief as of the date that it is provided. TI bases its knowledge and belief on information provided by third parties, and makes no representation or warranty as to the accuracy of such information. Efforts are underway to better integrate information from third parties. TI has taken and continues to take reasonable steps to provide representative and accurate information but may not have conducted destructive testing or chemical analysis on incoming materials and chemicals. TI and TI suppliers consider certain information to be proprietary, and thus CAS numbers and other limited information may not be available for release.

In no event shall TI's liability arising out of such information exceed the total purchase price of the TI part(s) at issue in this document sold by TI to Customer on an annual basis.

有关 TI 设计信息和资源的重要通知

德州仪器 (TI) 公司提供的技术、应用或其他设计建议、服务或信息，包括但不限于与评估模块有关的参考设计和材料（总称“TI 资源”），旨在帮助设计人员开发整合了 TI 产品的应用；如果您（个人，或如果是代表贵公司，则为贵公司）以任何方式下载、访问或使用了任何特定的 TI 资源，即表示贵方同意仅为该等目标，按照本通知的条款进行使用。

TI 所提供的 TI 资源，并未扩大或以其他方式修改 TI 对 TI 产品的公开适用的质保及质保免责声明；也未导致 TI 承担任何额外的义务或责任。TI 有权对其 TI 资源进行纠正、增强、改进和其他修改。

您理解并同意，在设计应用时应自行实施独立的分析、评价和判断，且应全权负责并确保应用的安全性，以及您的应用（包括应用中使用的 TI 产品）应符合所有适用的法律法规及其他相关要求。就您的应用声明，您具备制订和实施下列保障措施所需的一切必要专业知识，能够 (1) 预见故障的危险后果，(2) 监视故障及其后果，以及 (3) 降低可能导致危险的故障几率并采取适当措施。您同意，在使用或分发包含 TI 产品的任何应用前，您将彻底测试该等应用和该等应用所用 TI 产品的功能。除特定 TI 资源的公开文档中明确列出的测试外，TI 未进行任何其他测试。

您只有在为开发包含该等 TI 资源所列 TI 产品的应用时，才被授权使用、复制和修改任何相关单项 TI 资源。但并未依据禁止反言原则或其他法律授予您任何 TI 知识产权的任何其他明示或默示的许可，也未授予您 TI 或第三方的任何技术或知识产权的许可，该等产权包括但不限于任何专利权、版权、屏蔽作品权或与使用 TI 产品或服务的任何整合、机器制作、流程相关的其他知识产权。涉及或参考了第三方产品或服务的信息不构成使用此类产品或服务的许可或与其相关的保证或认可。使用 TI 资源可能需要您向第三方获得对该等第三方专利或其他知识产权的许可。

TI 资源系“按原样”提供。TI 兹免除对 TI 资源及其使用作出所有其他明确或默认的保证或陈述，包括但不限于对准确性或完整性、产权保证、无复发故障保证，以及适销性、适合特定用途和不侵犯任何第三方知识产权的任何默认保证。

TI 不负责任何申索，包括但不限于因组合产品所致或与之有关的申索，也不为您辩护或赔偿，即使该等产品组合已列于 TI 资源或其他地方。对因 TI 资源或其使用引起或与之有关的任何实际的、直接的、特殊的、附带的、间接的、惩罚性的、偶发的、从属或惩戒性损害赔偿，不管 TI 是否获悉可能会产生上述损害赔偿，TI 概不负责。

您同意向 TI 及其代表全额赔偿因您不遵守本通知条款和条件而引起的任何损害、费用、损失和/或责任。

本通知适用于 TI 资源。另有其他条款适用于某些类型的材料、TI 产品和服务的使用和采购。这些条款包括但不限于适用于 TI 的半导体产品 (<http://www.ti.com/sc/docs/stdterms.htm>)、评估模块和样品 (<http://www.ti.com/sc/docs/sampters.htm>) 的标准条款。

邮寄地址：上海市浦东新区世纪大道 1568 号中建大厦 32 楼，邮政编码：200122
Copyright © 2017 德州仪器半导体技术（上海）有限公司