

LMZ10501 最高输入电压为 5.5V 的 1A SIMPLE SWITCHER[®] 纳米模块

1 特性

- 输出电流最高可达 1A
- 输入电压范围为 2.7V 至 5.5V
- 输出电压范围为 0.6V 到 3.6V
- 效率高达 95%
- 集成电感
- 8 引脚无引线框架封装 (LLP)
- 结温范围为 -40°C 至 125°C
- 可调节输出电压
- 2.0MHz 固定脉宽调制 (PWM) 开关频率
- 集成补偿功能
- 软启动功能
- 电流限制保护
- 热关断保护
- 针对上电、断电和欠压条件的输入电压欠压锁定 (UVLO)
- 仅采用 5 个外部组件 - 电阻分压器和 3 个陶瓷电容
- 小型解决方案尺寸
- 低输出电压纹波
- 简单的组件选择和印刷电路板 (PCB) 布局布线
- 高效率有效降低系统产生的热量

$V_{IN} = 3.6V$ 时的典型效率

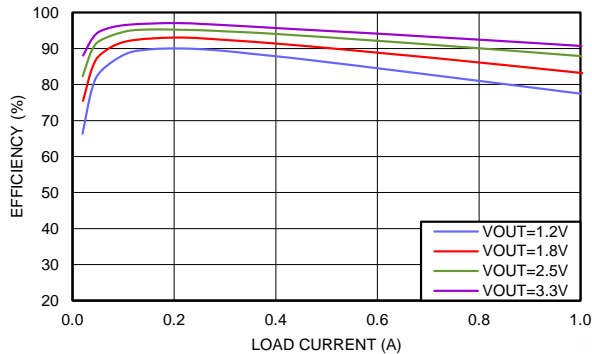

2 应用

- 由 3.3V 和 5V 电源轨到负载点的转换
- 空间受限型 应用
- 低输出噪声 应用
- 参考设计的快速链接:
 $V_{OUT} = 1.2V$ 、 $V_{OUT} = 1.8V$ 、
 $V_{OUT} = 2.5V$ 、 $V_{OUT} = 3.3V$

3 说明

LMZ10501 SIMPLE SWITCHER[®]纳米模块是一款简单易用的降压 DC-DC 解决方案，在空间受限类应用中最高可驱动 1A 负载电流。该器件仅需使用一个输入电容、一个输出电容、一个小型 V_{CON} 滤波电容和两个电阻即可实现基本运行。该纳米模块采用 8 引脚 LLP 封装并具有一个电感。该器件还提供基于内部电流限制的软启动、电流过载保护和热关断功能。

器件信息⁽¹⁾

器件型号	封装	封装尺寸 (标称值)
LMZ10501	SIL (8)	3.00mm x 2.60mm

(1) 如需了解所有可用封装，请参见数据表末尾的可订购产品附录。

辐射电磁干扰 (EMI) (CISPR22)
 $V_{IN} = 5.0V$ 、 $V_{OUT} = 1.8V$ 、 $I_{OUT} = 1A$

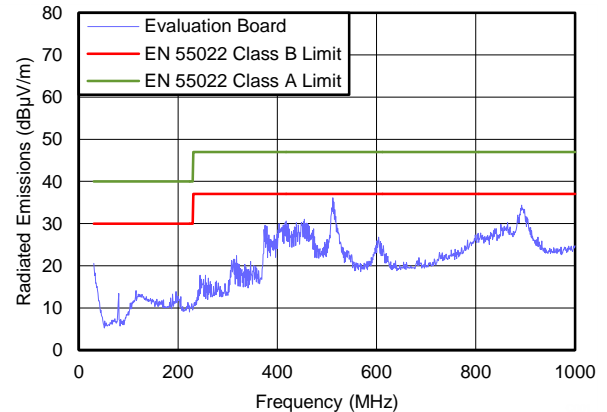

目录

<ul style="list-style-type: none"> 1 特性 1 2 应用 1 3 说明 1 4 修订历史记录 2 5 Pin Configuration and Functions 3 6 Specifications 4 <ul style="list-style-type: none"> 6.1 Absolute Maximum Ratings 4 6.2 Handling Ratings 4 6.3 Recommended Operating Conditions 4 6.4 Thermal Information 4 6.5 Electrical Characteristics 5 6.6 System Characteristics 5 6.7 Typical Characteristics 7 7 Detailed Description 9 <ul style="list-style-type: none"> 7.1 Overview 9 7.2 Functional Block Diagram 9 7.3 Feature Description 9 7.4 Device Functional Modes 11 	<ul style="list-style-type: none"> 8 Application and Implementation 13 <ul style="list-style-type: none"> 8.1 Application Information 13 8.2 Typical Application 13 9 Power Supply Recommendations 20 <ul style="list-style-type: none"> 9.1 Voltage Range 20 9.2 Current Capability 20 9.3 Input Connection 20 10 Layout 21 <ul style="list-style-type: none"> 10.1 Layout Guidelines 21 10.2 Layout Example 21 10.3 Package Considerations 22 11 器件和文档支持 23 <ul style="list-style-type: none"> 11.1 文档支持 23 11.2 商标 23 11.3 静电放电警告 23 11.4 Glossary 23 12 机械、封装和可订购信息 23
---	--

4 修订历史记录

注：之前版本的页码可能与当前版本有所不同。

Changes from Revision E (January 2014) to Revision F	Page
<ul style="list-style-type: none"> • 已添加 引脚配置和功能部分，处理额定值表，特性 描述 部分，器件功能模式，应用和实施部分，电源相关建议部分，布局部分，器件和文档支持部分以及机械、封装和可订购信息部分 1 	1

Changes from Revision D (March 2013) to Revision E	Page
<ul style="list-style-type: none"> • Added new package SIL0008A 3 	3

5 Pin Configuration and Functions

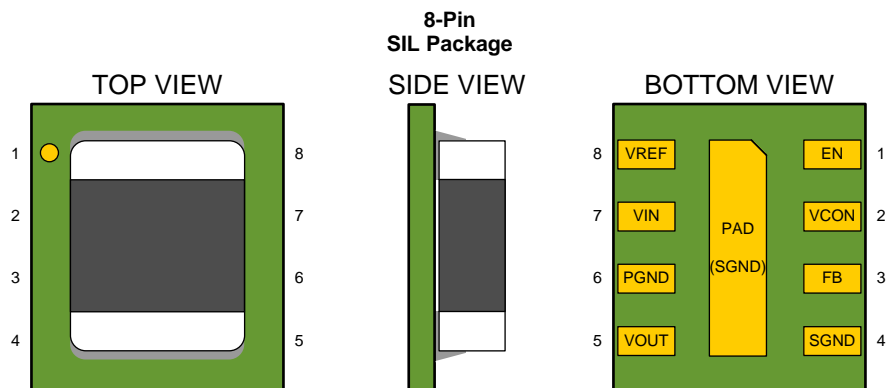

Pin Functions

PIN		I/O	DESCRIPTION
NAME	NO.		
EN	1	I	Enable Input. Set this digital input higher than 1.2V for normal operation. For shutdown, set low. Pin is internally pulled up to VIN and can be left floating for always-on operation.
VCON	2	I	Output voltage control pin. Connect to analog voltage from resistive divider or DAC/controller to set the VOUT voltage. $V_{OUT} = 2.5 \times V_{CON}$. Connect a small (470pF) capacitor from this pin to SGND to provide noise filtering.
FB	3	I	Feedback of the error amplifier. Connect directly to output capacitor to sense VOUT.
SGND	4	I	Ground for analog and control circuitry. Connect to PGND at a single point.
VOUT	5	O	Output Voltage. Connected to one terminal of the integrated inductor. Connect output filter capacitor between VOUT and PGND.
PGND	6	I	Power ground for the power MOSFETs and gate-drive circuitry.
VIN	7	I	Voltage supply input. Connect ceramic capacitor between VIN and PGND as close as possible to these two pins. Typical capacitor values are between 4.7μF and 22μF.
VREF	8	O	2.35-V voltage reference output. Typically connected to VCON pin through a resistive divider to set the output voltage.
PAD		I	The center pad underneath the SIL0008A package is internally tied to SGND. This pad should be connected to the ground plane for improved thermal performance.

6 Specifications

6.1 Absolute Maximum Ratings

 over operating free-air temperature range (unless otherwise noted) ⁽¹⁾⁽²⁾⁽³⁾

	MIN	MAX	UNIT
VIN, VREF to SGND	-0.2	+6.0	V
PGND to SGND	-0.2	+0.2	V
EN, FB, VCON	(SGND -0.2)	(VIN +0.2) w/6.0 max	V
VOUT	(PGND -0.2)	(VIN +0.2) w/6.0 max	V
Junction Temperature (T _{J-MAX})	-40	125	°C
Maximum Lead Temperature		260	°C

- (1) Stresses beyond those listed under Absolute Maximum Ratings may cause permanent damage to the device. These are stress ratings only, which do not imply functional operation of the device at these or any other conditions beyond those indicated under [Recommended Operating Conditions](#). Exposure to absolute-maximum-rated conditions for extended periods may affect device reliability.
- (2) If Military/Aerospace specified devices are required, please contact the Texas Instruments Sales Office/ Distributors for availability and specifications.
- (3) Absolute Maximum Ratings are limits beyond which damage to the device may occur. Operating Ratings are conditions under which operation of the device is intended to be functional. For the Electrical Characteristics table for specifications and test conditions.

6.2 Handling Ratings

	MIN	MAX	UNIT
T _{stg} Storage temperature range	-65	150	°C
V _(ESD) Electrostatic discharge	Human body model (HBM), per ANSI/ESDA/JEDEC JS-001, all pins ⁽¹⁾	1000	V
	Charged device model (CDM), per JEDEC specification JESD22-C101, all pins ⁽²⁾	250	V

- (1) JEDEC document JEP155 states that 500-V HBM allows safe manufacturing with a standard ESD control process.
- (2) JEDEC document JEP157 states that 250-V CDM allows safe manufacturing with a standard ESD control process.

6.3 Recommended Operating Conditions

over operating free-air temperature range (unless otherwise noted)

	MIN	MAX	UNIT
Input Voltage Range	2.7	5.5	V
Recommended Load Current	0	1000	mA
Junction Temperature (T _J) Range	-40	125	°C

6.4 Thermal Information

THERMAL METRIC ⁽¹⁾		LMZ10501	UNIT
		SIL 8 PINS	
R _{θJA}	Junction-to-ambient thermal resistance ⁽²⁾	SIL0008A Package	45.8
R _{θJC(top)}	Junction-to-case (top) thermal resistance		25
R _{θJB}	Junction-to-board thermal resistance		9.2
ψ _{JT}	Junction-to-top characterization parameter		1.5
ψ _{JB}	Junction-to-board characterization parameter		9.1
R _{θJC(bot)}	Junction-to-case (bottom) thermal resistance		25

- (1) For more information about traditional and new thermal metrics, see the *IC Package Thermal Metrics* application report, [SPRA953](#).
- (2) Junction-to-ambient thermal resistance (θ_{JA}) is based on 4 layer board thermal measurements, performed under the conditions and guidelines set forth in the JEDEC standards JESD51-1 to JESD51-11. θ_{JA} varies with PCB copper area, power dissipation, and airflow.

6.5 Electrical Characteristics

over operating free-air temperature range (unless otherwise noted). Typical values represent the most likely parametric norm at $T_J = 25^\circ\text{C}$, and are provided for reference purposes only. Unless otherwise stated the following conditions apply: $V_{IN} = 3.6\text{ V}$, $V_{EN} = 1.2\text{ V}$. ⁽¹⁾

PARAMETER		TEST CONDITIONS	MIN ⁽¹⁾	TYP ⁽²⁾	MAX ⁽¹⁾	UNIT
SYSTEM PARAMETERS						
$V_{REF} \times \text{GAIN}$	Reference voltage x VCON to FB Gain	$V_{IN} = V_{EN} = 5.5\text{V}$, $V_{CON} = 1.44\text{V}$	5.7575	5.875	5.9925	V
GAIN	VCON to FB Gain	$V_{IN} = 5.5\text{V}$, $V_{CON} = 1.44\text{V}$	2.4375	2.5	2.5750	V/V
V_{INUVLO}	VIN rising threshold		2.24	2.41	2.64	V
$V_{INUVLO\ HYST}$	VIN UVLO hysteresis		120	165	200	mV
I_{SHDN}	Shutdown supply current	$V_{IN} = 3.6\text{V}$, $V_{EN} = 0.5\text{V}$ ⁽³⁾		11	18	μA
I_q	DC bias current into VIN	$V_{IN} = 5.5\text{V}$, $V_{CON} = 1.6\text{V}$, $I_{OUT} = 0\text{A}$		6.5	9.5	mA
$R_{DROPOUT}$	VIN to VOUT resistance	$I_{OUT} = 200\text{ mA}$		305	575	m Ω
I_{LIM}	DC Output Current Limit	$V_{CON} = 1.72\text{V}$ ⁽⁴⁾	1025	1350		mA
F_{OSC}	Internal oscillator frequency		1.75	2.0	2.25	MHz
$V_{IH,ENABLE}$	Enable logic HIGH voltage		1.2			V
$V_{IL,ENABLE}$	Enable logic LOW voltage				0.5	V
T_{SD}	Thermal shutdown	Rising Threshold		150		$^\circ\text{C}$
$T_{SD-HYST}$	Thermal shutdown hysteresis			20		$^\circ\text{C}$
D_{MAX}	Maximum duty cycle			100%		
T_{ON-MIN}	Minimum on-time			50		ns
θ_{JA}	SIL0008A Package Thermal Resistance	20mm x 20mm board 2 layers, 2 oz copper, 0.5W, no airflow		77		$^\circ\text{C/W}$
		15mm x 15mm board 2 layers, 2 oz copper, 0.5W, no airflow		88		
		10mm x 10mm board 2 layers, 2 oz copper, 0.5W, no airflow		107		

- (1) Min and Max limits are 100% production tested at 25°C . Limits over the operating temperature range are guaranteed through correlation using Statistical Quality Control (SQC) methods. Limits are used to calculate the Average Outgoing Quality Level (AOQL).
- (2) Typical numbers are at 25°C and represent the most likely parametric norm.
- (3) Shutdown current includes leakage current of the high side PFET.
- (4) Current limit is built-in, fixed, and not adjustable.

6.6 System Characteristics

The following specifications are ensured by design providing the component values in [Figure 12](#) are used ($C_{IN} = C_{OUT} = 10\ \mu\text{F}$, 6.3 V, 0603, TDK C1608X5R0J106K). **These parameters are not ensured by production testing.** Unless otherwise stated the following conditions apply: $T_A = 25^\circ\text{C}$.

PARAMETER		TEST CONDITIONS	MIN	TYP	MAX	UNIT
$\Delta V_{OUT}/V_{OUT}$	Output Voltage Regulation Over Line Voltage and Load Current	$V_{OUT} = 0.6\text{ V}$ $\Delta V_{IN} = 2.7\text{ V to }4.2\text{ V}$ $\Delta I_{OUT} = 0\text{A to }1\text{A}$		$\pm 1.75\%$		
$\Delta V_{OUT}/V_{OUT}$	Output Voltage Regulation Over Line Voltage and Load Current	$V_{OUT} = 1.5\text{ V}$ $\Delta V_{IN} = 2.7\text{ V to }5.5\text{ V}$ $\Delta I_{OUT} = 0\text{A to }1\text{A}$		$\pm 0.92\%$		
$\Delta V_{OUT}/V_{OUT}$	Output Voltage Regulation Over Line Voltage and Load Current	$V_{OUT} = 3.6\text{ V}$ $\Delta V_{IN} = 4.0\text{ V to }5.5\text{ V}$ $\Delta I_{OUT} = 0\text{A to }1\text{A}$		$\pm 0.38\%$		
V_{REF} T_{RISE}	Rise time of reference voltage	EN = Low to High, $V_{IN} = 4.2\text{ V}$ $V_{OUT} = 2.7\text{ V}$, $I_{OUT} = 1\text{A}$		10		μs

System Characteristics (continued)

The following specifications are ensured by design providing the component values in [Figure 12](#) are used ($C_{IN} = C_{OUT} = 10 \mu\text{F}$, 6.3 V, 0603, TDK C1608X5R0J106K). **These parameters are not ensured by production testing.** Unless otherwise stated the following conditions apply: $T_A = 25^\circ\text{C}$.

PARAMETER		TEST CONDITIONS	MIN	TYP	MAX	UNIT
η	Peak Efficiency	$V_{IN} = 5.0 \text{ V}$, $V_{OUT} = 3.3 \text{ V}$ $I_{OUT} = 200 \text{ mA}$		95%		
	Full Load Efficiency	$V_{IN} = 5.0 \text{ V}$, $V_{OUT} = 3.6 \text{ V}$ $I_{OUT} = 1000 \text{ mA}$		91%		
V_{OUT} Ripple	Output voltage ripple	$V_{IN} = 5.0 \text{ V}$, $V_{OUT} = 1.8 \text{ V}$ $I_{OUT} = 1000 \text{ mA}$		10		mV pk-pk
Line Transient	Line transient response	$V_{IN} = 2.7 \text{ V}$ to 5.5 V , $T_R = T_F = 10 \mu\text{s}$, $V_{OUT} = 1.8 \text{ V}$, $I_{OUT} = 1000 \text{ mA}$		30		mV pk-pk
Load Transient	Load transient response	$V_{IN} = 5.0 \text{ V}$ $T_R = T_F = 40 \mu\text{s}$, $V_{OUT} = 1.8 \text{ V}$ $I_{OUT} = 100 \text{ mA}$ to 1000 mA		30		mV pk-pk

6.7 Typical Characteristics

Unless otherwise specified the following conditions apply: $V_{IN} = 3.6\text{ V}$, $T_A = 25^\circ\text{C}$

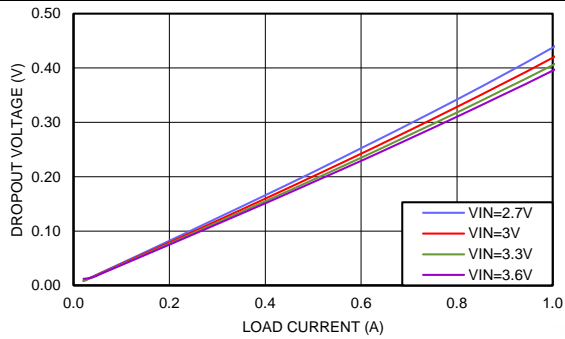

Figure 1. Dropout Voltage vs Load Current and Input Voltage, $T_A = 85^\circ\text{C}$

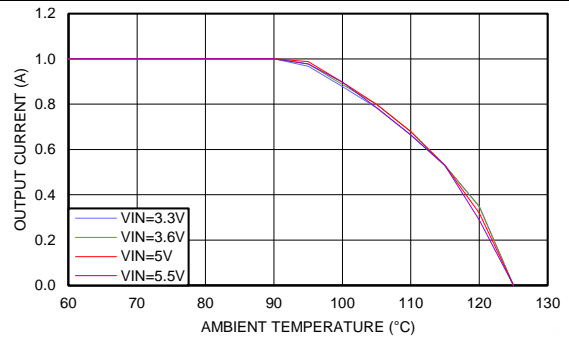

Figure 2. Thermal Derating $V_{OUT} = 1.2\text{ V}$, $\Theta_{JA} = 77^\circ\text{C/W}$

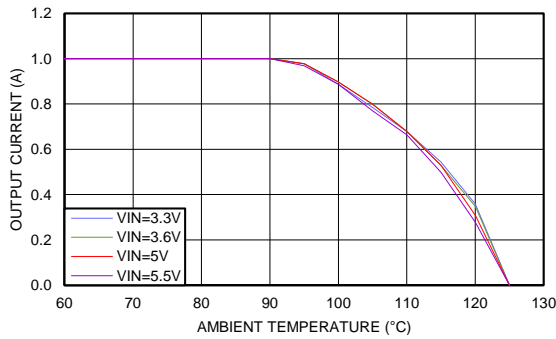

Figure 3. Thermal Derating $V_{OUT} = 1.8\text{ V}$, $\Theta_{JA} = 77^\circ\text{C/W}$

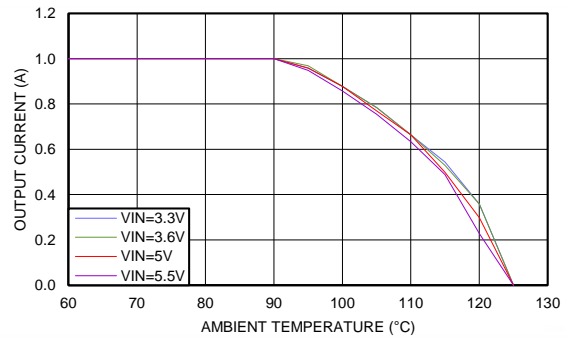

Figure 4. Thermal Derating $V_{OUT} = 2.5\text{ V}$, $\Theta_{JA} = 77^\circ\text{C/W}$

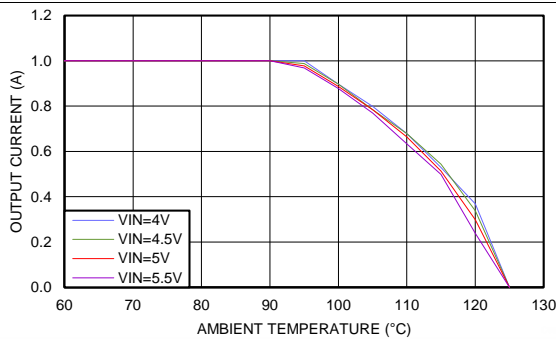

Figure 5. Thermal Derating $V_{OUT} = 3.3\text{ V}$, $\Theta_{JA} = 77^\circ\text{C/W}$

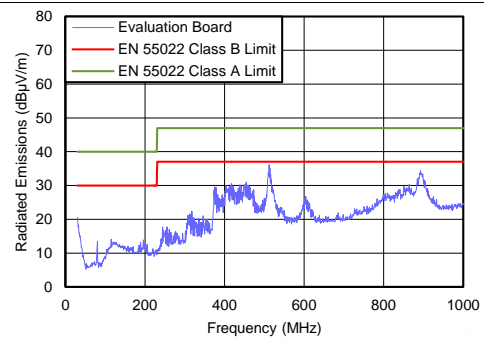

Figure 6. Radiated EMI (Cispr22) $V_{IN} = 5.0\text{ V}$, $V_{OUT} = 1.8\text{ V}$, $I_{OUT} = 1\text{-A}$ Default Evaluation Board BOM

Typical Characteristics (continued)

Unless otherwise specified the following conditions apply: $V_{IN} = 3.6\text{ V}$, $T_A = 25^\circ\text{C}$

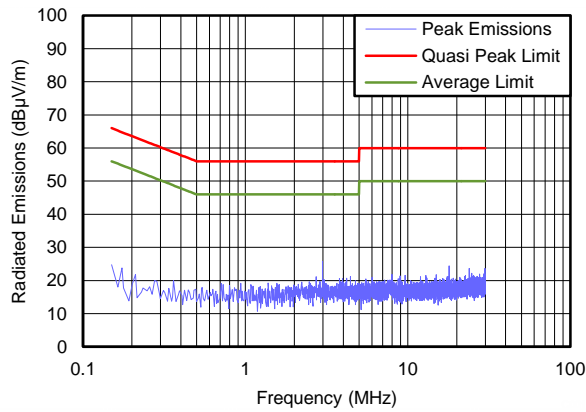

Figure 7. Conducted EMI $V_{IN} = 5.0\text{ V}$, $V_{OUT} = 1.8\text{ V}$, $I_{OUT} = 1\text{-A}$ Default Evaluation Board BOM with Additional $2.2\text{-}\mu\text{H}$ $1\text{-}\mu\text{F}$ LC Input Filter

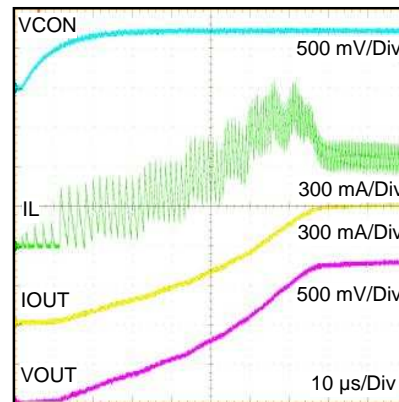

Figure 8. Startup

7 Detailed Description

7.1 Overview

The LMZ10501 SIMPLE SWITCHER® nano module is an easy-to-use step-down DC-DC solution capable of driving up to 1A load in space-constrained applications. Only an input capacitor, an output capacitor, a small V_{CON} filter capacitor, and two resistors are required for basic operation. The nano module comes in 8-pin LLP footprint package with an integrated inductor. The LMZ10501 operates in fixed 2.0MHz PWM (Pulse Width Modulation) mode, and is designed to deliver power at maximum efficiency. The output voltage is typically set by using a resistive divider between the built-in reference voltage V_{REF} and the control pin V_{CON} . The V_{CON} pin is the positive input to the error amplifier. The output voltage of the LMZ10501 can also be dynamically adjusted between 0.6V and 3.6V by driving the V_{CON} pin externally. Internal current limit softstart function, current overload protection, and thermal shutdown are also provided.

7.2 Functional Block Diagram

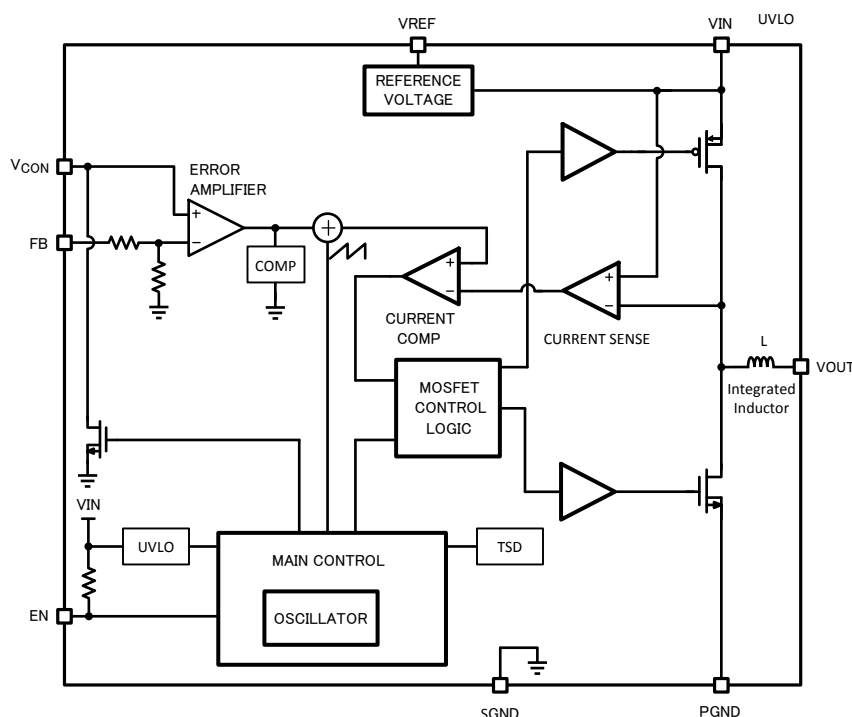

7.3 Feature Description

7.3.1 Current Limit

The LMZ10501 current limit feature protects the module during an overload condition. The circuit employs positive peak current limit in the PFET and negative peak current limit in the NFET switch. The positive peak current through the PFET is limited to 1.7A (typ.). When the current reaches this limit threshold the PFET switch is immediately turned off until the next switching cycle. This behavior continues on a cycle-by-cycle basis until the overload condition is removed from the output. The typical negative peak current limit through the NFET switch is -0.6A (typ.).

The ripple of the inductor current depends on the input and output voltages. This means that the DC level of the output current when the peak current limiting occurs will also vary over the line voltage and the output voltage level. Refer to the DC Output Current Limit plots in the [Typical Characteristics](#) section for more information.

Feature Description (continued)

7.3.2 Startup Behavior and Softstart

The LMZ10501 features a current limit based soft start circuit in order to prevent large in-rush current and output overshoot as V_{OUT} is ramping up. This is achieved by gradually increasing the PFET current limit threshold to the final operating value as the output voltage ramps during startup. The maximum allowed current in the inductor is stepped up in a staircase profile for a fixed number of switching periods in each step. Additionally, the switching frequency in the first step is set at 450kHz and is then increased for each of the following steps until it reaches 2MHz at the final step of current limiting. This current limiting behavior is illustrated in [Figure 9](#) and allows for a smooth V_{OUT} ramp up.

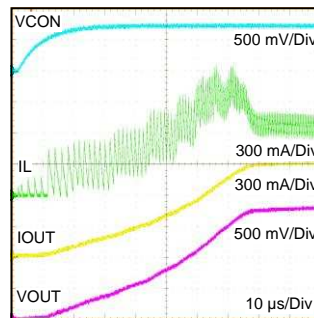

Figure 9. Startup Behavior of Current Limit Based Softstart.

The soft start rate is also limited by the V_{CON} ramp up rate. The V_{CON} pin is discharged internally through a pull down device before startup occurs. This is done to deplete any residual charge on the V_{CON} filter capacitor and allow the V_{CON} voltage to ramp up from 0V when the part is started. The events that cause V_{CON} discharge are thermal shutdown, UVLO, EN low, or output short circuit detection. The minimum recommended capacitance on V_{CON} is 220pF and the maximum is 1nF. The duration of startup current limiting sequence takes approximately 75 μ s. After the sequence is completed, the feedback voltage is monitored for output short circuit events.

7.3.3 Output Short Circuit Protection

In addition to cycle by cycle current limit, the LMZ10501 features a second level of short circuit protection. If the load pulls the output voltage down and the feedback voltage falls to 0.375 V, the output short circuit protection will engage. In this mode the internal PFET switch is turned OFF after the current limit comparator trips and the beginning of the next cycle is inhibited for approximately 230 μ s. This forces the inductor current to ramp down and limits excessive current draw from the input supply when the output of the regulator is shorted. The synchronous rectifier is always OFF in this mode. After 230 μ s of non-switching a new startup sequence is initiated. During this new startup sequence the current limit is gradually stepped up to the nominal value as illustrated in the [Startup Behavior and Softstart](#) section. After the startup sequence is completed again, the feedback voltage is monitored for output short circuit. If the short circuit is still persistent after the new startup sequence, switching will be stopped again and there will be another 230- μ s off period. A persistent output short condition results in a hiccup behavior where the LMZ10501 goes through the normal startup sequence, then detects the output short at the end of startup, terminates switching for 230 μ s, and repeats this cycle until the output short is released. This behavior is illustrated in [Figure 10](#).

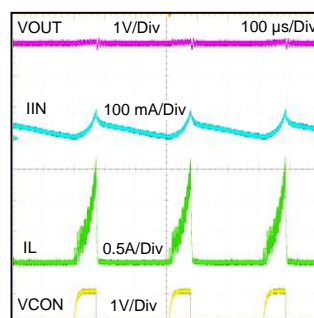

Figure 10. Hiccup Behavior with Persistent Output Short Circuit.

Feature Description (continued)

Since the output current is limited during normal startup by the softstart function, the current charging the output capacitor is also limited. This results in a smooth V_{OUT} ramp up to nominal voltage. However, using excessively large output capacitance or V_{CON} capacitance under normal conditions can prevent the output voltage from reaching 0.375 V at the end of the startup sequence. In such cases the module will maintain the described above hiccup mode and the output voltage will not ramp up to final value. To cause this condition, one would have to use unnecessarily large output capacitance for 1A load applications. See the [Input And Output Capacitor Selection](#) section for guidance on maximum capacitances for different output voltage settings.

7.3.4 Thermal Overload Protection

The junction temperature of the LMZ10501 should not be allowed to exceed its maximum operating rating of 125°C. Thermal protection is implemented by an internal thermal shutdown circuit which activates at 150°C (typ). When this temperature is reached, the device enters a low power standby state. In this state switching remains off causing the output voltage to fall. Also, the V_{CON} capacitor is discharged to SGND. When the junction temperature falls back below 130°C (typ) normal startup occurs and V_{OUT} rises smoothly from 0V. Applications requiring maximum output current may require derating at elevated ambient temperature. See the [Typical Characteristics](#) section for thermal derating plots for various output voltages.

7.4 Device Functional Modes

7.4.1 Circuit Operation

The LMZ10501 is a synchronous Buck power module using a PFET for the high side switch and an NFET for the synchronous rectifier switch. The output voltage is regulated by modulating the PFET switch on-time. The circuit generates a duty-cycle modulated rectangular signal. The rectangular signal is averaged using a low pass filter formed by the integrated inductor and an output capacitor. The output voltage is equal to the average of the duty-cycle modulated rectangular signal. In PWM mode, the switching frequency is constant. The energy per cycle to the load is controlled by modulating the PFET on-time, which controls the peak inductor current. In current mode control architecture, the inductor current is compared with the slope compensated output of the error amplifier. At the rising edge of the clock, the PFET is turned ON, ramping up the inductor current with a slope of $(V_{IN} - V_{OUT})/L$. The PFET is ON until the current signal equals the error signal. Then the PFET is turned OFF and NFET is turned ON, ramping down the inductor current with a slope of V_{OUT}/L . At the next rising edge of the clock, the cycle repeats. An increase of load pulls the output voltage down, resulting in an increase of the error signal. As the error signal goes up, the peak inductor current is increased, elevating the average inductor current and responding to the heavier load. To ensure stability, a slope compensation ramp is subtracted from the error signal and internal loop compensation is provided.

7.4.2 Input Under Voltage Detection

The LMZ10501 implements an under voltage lock out (UVLO) circuit to ensure proper operation during startup, shutdown and input supply brownout conditions. The circuit monitors the voltage at the V_{IN} pin to ensure that sufficient voltage is present to bias the regulator. If the under voltage threshold is not met, all functions of the controller are disabled and the controller remains in a low power standby state.

7.4.3 Shutdown Mode

To shutdown the LMZ10501, pull the EN pin low (< 0.5 V). In the shutdown mode all internal circuits are turned OFF.

7.4.4 EN Pin Operation

The EN pin is internally pulled up to V_{IN} through a 790kΩ (typ.) resistor. This allows the nano module to be enabled by default when the EN pin is left floating. In such cases V_{IN} will set EN high when V_{IN} reaches 1.2 V. As the input voltage continues to rise, operation will start once V_{IN} exceeds the under-voltage lockout (UVLO) threshold. To set EN high externally, pull it up to 1.2 V or higher. Note that the voltage on EN must remain at less than $V_{IN} + 0.2$ V due to absolute maximum ratings of the device.

Device Functional Modes (continued)

7.4.5 Internal Synchronous Rectification

The LMZ10501 uses an internal NFET as a synchronous rectifier to minimize the switch voltage drop and increase efficiency. The NFET is designed to conduct through its intrinsic body diode during the built-in dead time between the PFET on-time and the NFET on-time. This eliminates the need for an external diode. The dead time between the PFET and NFET connection prevents shoot through current from V_{IN} to PGND during the switching transitions.

7.4.6 High Duty Cycle Operation

The LMZ10501 features a transition mode designed to extend the output regulation range to the minimum possible input voltage. As the input voltage decreases closer and closer to V_{OUT} , the off-time of the PFET gets smaller and smaller and the duty cycle eventually needs to reach 100% to support the output voltage. The input voltage at which the duty cycle reaches 100% is the edge of regulation. When the LMZ10501 input voltage is lowered, such that the off-time of the PFET reduces to less than 35ns, the LMZ10501 doubles the switching period to extend the off-time for that V_{IN} and maintain regulation. If V_{IN} is lowered even more, the off-time of the PFET will reach the 35ns mark again. The LMZ10501 will then reduce the frequency again, achieving less than 100% duty cycle operation and maintaining regulation. As V_{IN} is lowered even more, the LMZ10501 will continue to scale down the frequency, aiming to maintain at least 35ns off time. Eventually, as the input voltage decreases further, 100% duty cycle is reached. This behavior of extending the V_{IN} regulation range is illustrated in Figure 11.

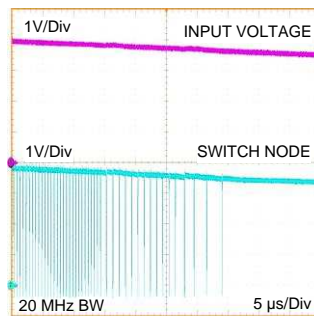

Figure 11. High Duty Cycle Operation and Switching Frequency Reduction

8 Application and Implementation

NOTE

Information in the following applications sections is not part of the TI component specification, and TI does not warrant its accuracy or completeness. TI's customers are responsible for determining suitability of components for their purposes. Customers should validate and test their design implementation to confirm system functionality.

8.1 Application Information

This section describes a simple design procedure. Alternatively, WEBENCH® can be used to create and simulate a design using the LMZ10501. The WEBENCH® tool can be accessed from the LMZ10501 product folder at <http://www.ti.com/product/lmz10501>. For designs with typical output voltages (1.2 V, 1.8 V, 2.5 V, 3.3 V), jump to the [Application Curves](#) section for quick reference designs.

8.2 Typical Application

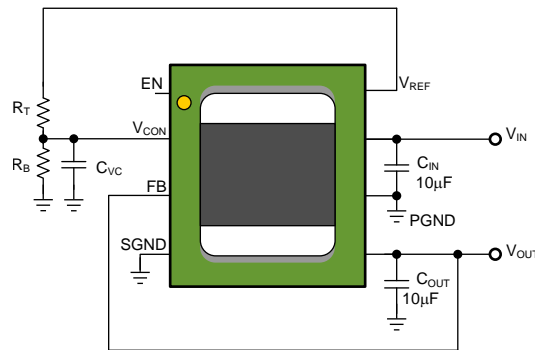

Figure 12. Typical Application Circuit

8.2.1 Design Requirements

The detailed design procedure is based on the required input and output voltage specifications for the design. The input voltage range of the LMZ10501 is 2.7V to 5.5V. The output voltage range is 0.6V to 3.6V. The output current capability is 1A.

8.2.2 Detailed Design Procedure

8.2.2.1 Setting The Output Voltage

The LMZ10501 provides a fixed 2.35V V_{REF} voltage output. As shown in Figure 12 above, a resistive divider formed by R_T and R_B sets the V_{CON} pin voltage level. The V_{OUT} voltage tracks V_{CON} and is governed by the following relationship:

$$V_{OUT} = GAIN \times V_{CON}$$

$$\text{where GAIN is } 2.5V/V \text{ from } V_{CON} \text{ to } V_{FB} \quad (1)$$

This equation is valid for output voltages between 0.6V and 3.6V and corresponds to V_{CON} voltage between 0.24V and 1.44V, respectively.

8.2.2.1.1 R_T And R_B Selection For Fixed V_{OUT}

The parameters affecting the output voltage setting are the R_T , R_B , and the product of the V_{REF} voltage x GAIN. The V_{REF} voltage is typically 2.35V. Since V_{CON} is derived from V_{REF} via R_T and R_B ,

$$V_{CON} = V_{REF} \times R_B / (R_B + R_T) \quad (2)$$

After substitution,

$$V_{OUT} = V_{REF} \times GAIN \times R_B / (R_B + R_T) \quad (3)$$

$$R_T = (GAIN \times V_{REF} / V_{OUT} - 1) \times R_B \quad (4)$$

Typical Application (continued)

The ideal product of $GAIN \times V_{REF} = 5.875 \text{ V}$.

Choose R_T to be between $80\text{k}\Omega$ and $300\text{k}\Omega$. Then, R_B can be calculated using [Equation 5](#) below.

$$R_B = (V_{OUT} / (5.875 \text{ V} - V_{OUT})) \times R_T \quad (5)$$

Note that the resistance of R_T should be $\geq 80\text{k}\Omega$. This ensures that the V_{REF} output current loading is not exceeded and the reference voltage is maintained. The current loading on V_{REF} should not be greater than $30 \mu\text{A}$.

8.2.2.1.2 Output Voltage Accuracy Optimization

Each nano module is optimized to achieve high V_{OUT} accuracy. [Equation 1](#) shows that, by design, the output voltage is a function of the V_{CON} voltage and the gain from V_{CON} to V_{FB} . The voltage at V_{CON} is derived from V_{REF} . Therefore, as shown in [Equation 3](#), the accuracy of the output voltage is a function of the $V_{REF} \times GAIN$ product as well as the tolerance of the R_T and R_B resistors. The typical $V_{REF} \times GAIN$ product by design is 5.875 V . Each nano module's V_{REF} voltage is trimmed so that this product is as close to the ideal 5.875 V value as possible, achieving high V_{OUT} accuracy. See the [Features Description](#) section for the $V_{REF} \times GAIN$ product tolerance limits.

8.2.2.2 Dynamic Output Voltage Scaling

The V_{CON} pin on the LMZ10501 can be driven externally by a DAC to scale the output voltage dynamically. The output voltage $V_{OUT} = 2.5 \text{ V/V} \times V_{CON}$. When driving V_{CON} with a source different than V_{REF} place a $1.5\text{k}\Omega$ resistor in series with the V_{CON} pin. Current limiting the external V_{CON} helps to protect this pin and allows the V_{CON} capacitor to be fully discharged to 0V after fault conditions.

8.2.2.3 Integrated Inductor

The LMZ10501 includes an inductor with over 1.2A DC current rating and soft saturation profile for up to 2A . This inductor allows for low package height and provides an easy to use, compact solution with reduced EMI.

8.2.2.4 Input And Output Capacitor Selection

The LMZ10501 is designed for use with low ESR multi-layer ceramic capacitors (MLCC) for its input and output filters. Using a $10 \mu\text{F}$ 0603 or 0805 with 6.3V or 10V rating ceramic input capacitor typically provides sufficient V_{IN} bypass. Use of multiple $4.7 \mu\text{F}$ or $2.2 \mu\text{F}$ capacitors can also be considered. Ceramic capacitors with X5R and X7R temperature characteristics are recommended for both input and output filters. These provide an optimal balance between small size, cost, reliability, and performance for space sensitive applications.

The DC voltage bias characteristics of the capacitors must be considered when selecting the DC voltage rating and case size of these components. The effective capacitance of an MLCC is typically reduced by the DC voltage bias applied across its terminals. For example, a typical 0805 case size X5R $6.3 \text{ V } 10 \mu\text{F}$ ceramic capacitor may only have $4.8 \mu\text{F}$ left in it when a 5.0-V DC bias is applied. Similarly, a typical 0603 case size X5R $6.3\text{V } 10 \mu\text{F}$ ceramic capacitor may only have $2.4 \mu\text{F}$ at the same 5.0V DC. Smaller case size capacitors may have even larger percentage drop in value with DC bias.

The optimum output capacitance value is application dependent. Too small output capacitance can lead to instability due to lower loop phase margin. On the other hand, if the output capacitor is too large, it may prevent the output voltage from reaching the 0.375 V required voltage level at the end of the startup sequence. In such cases, the output short circuit protection can be engaged and the nano module will enter a hiccup mode as described in the [Output Short Circuit Protection](#) section. [Table 1](#) sets the minimum output capacitance for stability and maximum output capacitance for proper startup for various output voltage settings. Note that the maximum C_{OUT} value in [Table 1](#) assumes that the filter capacitance on V_{CON} is the maximum recommended value of 1nF and the R_T resistor value is less than $300\text{k}\Omega$. Lower V_{CON} capacitance can extend the maximum C_{OUT} range. There is no great performance benefit in using excessive C_{OUT} values.

Typical Application (continued)
Table 1. Output Capacitance Range

Output Voltage	Minimum C _{OUT}	Suggested C _{OUT}	Maximum C _{OUT}
0.6V	4.7μF	10μF	47μF
1.0V	3.3μF	10μF	47μF
1.2V	3.3μF	10μF	47μF
1.8V	3.3μF	10μF	68μF
2.5V	3.3μF	10μF	100μF
3.3V	3.3μF	10μF	100μF

Use of multiple 4.7-μF or 2.2-μF output capacitors can be considered for reduced effective ESR and smaller output voltage ripple. In addition to the main output capacitor, small 0.1-μF – 0.01-μF parallel capacitors can be used to reduce high frequency noise.

8.2.3 Application Curves

8.2.3.1 $V_{OUT} = 1.2\text{ V}$

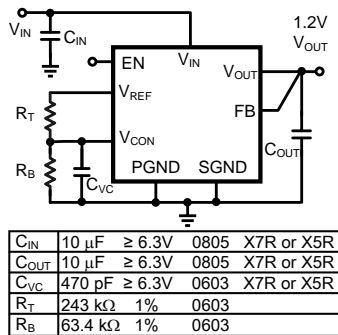

Figure 13. Schematic $V_{OUT} = 1.2\text{ V}$

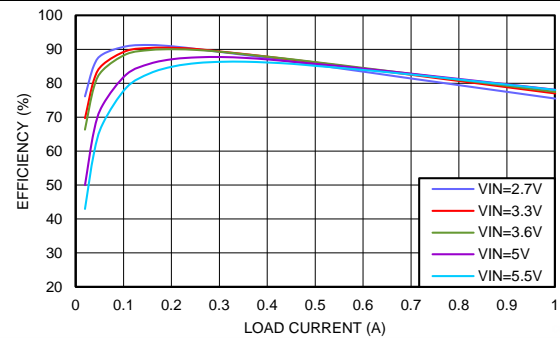

Figure 14. Efficiency $V_{OUT} = 1.2\text{ V}$

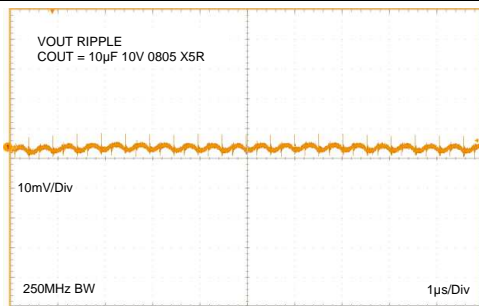

Figure 15. Output Ripple $V_{OUT} = 1.2\text{ V}$

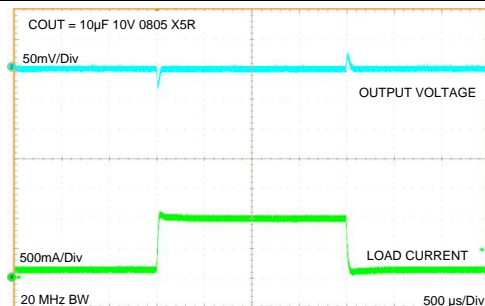

Figure 16. Load Transient $V_{OUT} = 1.2\text{ V}$

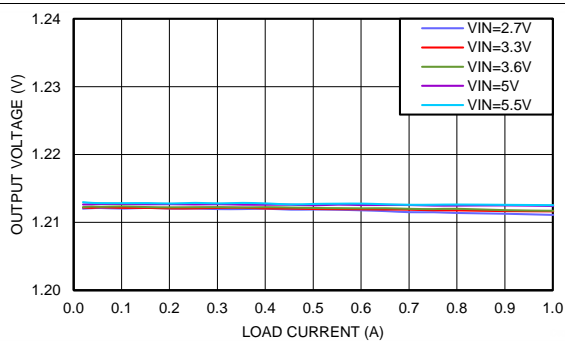

Figure 17. Line and Load Regulation $V_{OUT} = 1.2\text{ V}$

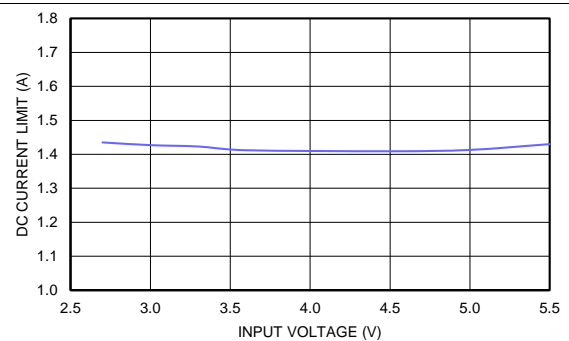

Figure 18. DC Current Limit $V_{OUT} = 1.2\text{ V}$, $T_A=85^\circ\text{C}$

8.2.3.2 $V_{OUT} = 1.8\text{ V}$

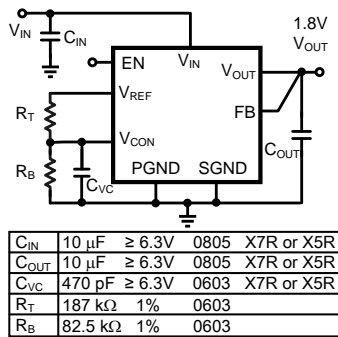

Figure 19. Schematic $V_{OUT} = 1.8\text{ V}$

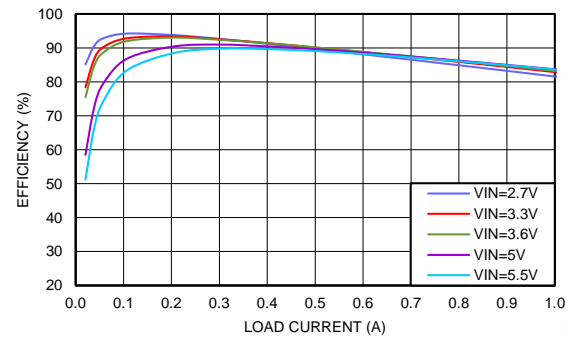

Figure 20. Efficiency $V_{OUT} = 1.8\text{ V}$

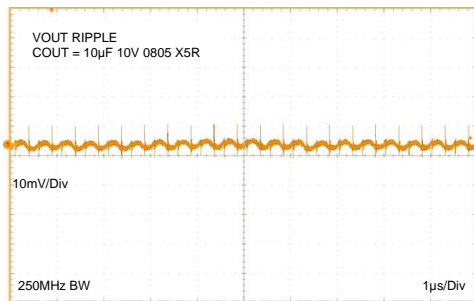

Figure 21. Output Ripple $V_{OUT} = 1.8\text{ V}$

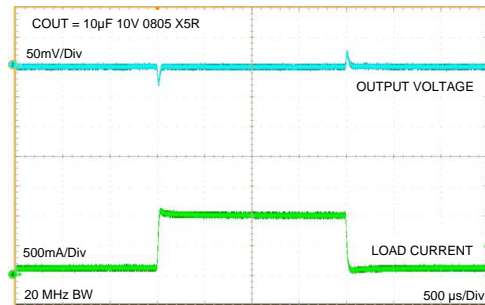

Figure 22. Load Transient $V_{OUT} = 1.8\text{ V}$

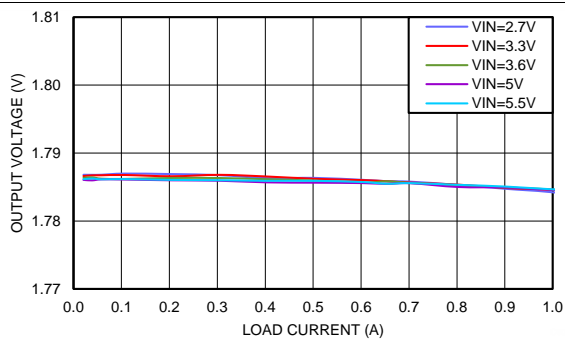

Figure 23. Line and Load Regulation $V_{OUT} = 1.8\text{ V}$

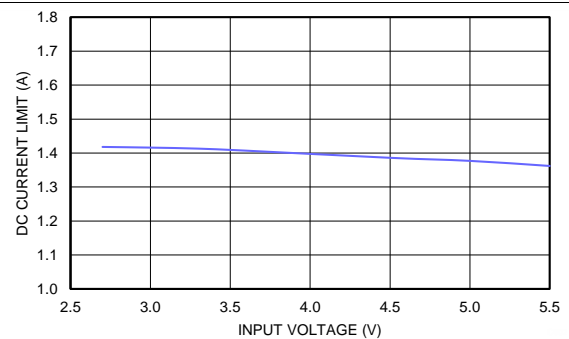

Figure 24. DC Current Limit $V_{OUT} = 1.8\text{ V}$, $T_A = 85^\circ\text{C}$

LMZ10501

ZHCS572F –MAY 2011–REVISED NOVEMBER 2014

www.ti.com.cn

8.2.3.3 $V_{OUT} = 2.5\text{ V}$

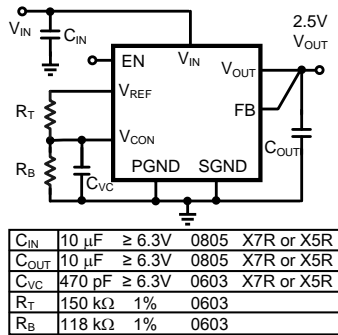

Figure 25. Schematic $V_{OUT} = 2.5\text{ V}$

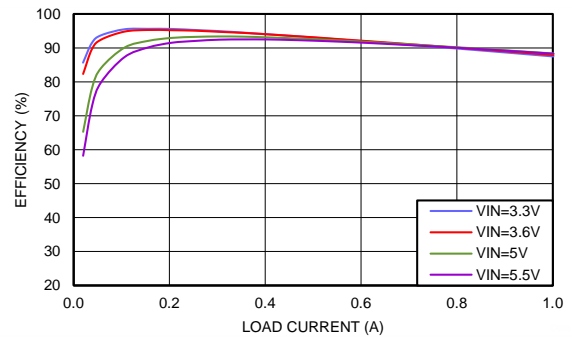

Figure 26. Efficiency $V_{OUT} = 2.5\text{ V}$

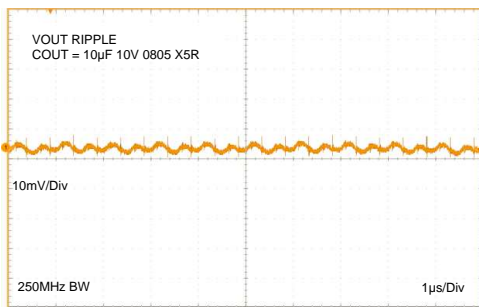

Figure 27. Output Ripple $V_{OUT} = 2.5\text{ V}$

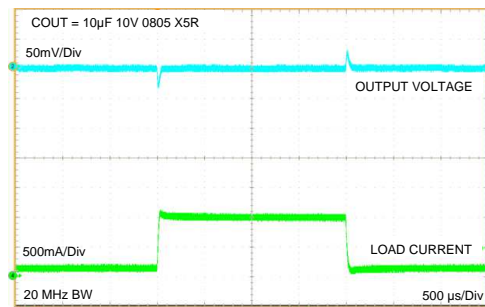

Figure 28. Load Transient $V_{OUT} = 2.5\text{ V}$

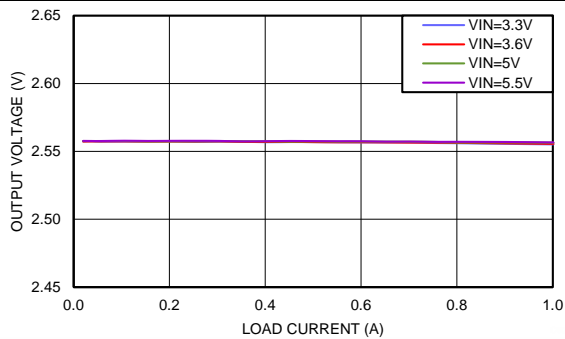

Figure 29. Line and Load Regulation $V_{OUT} = 2.5\text{ V}$

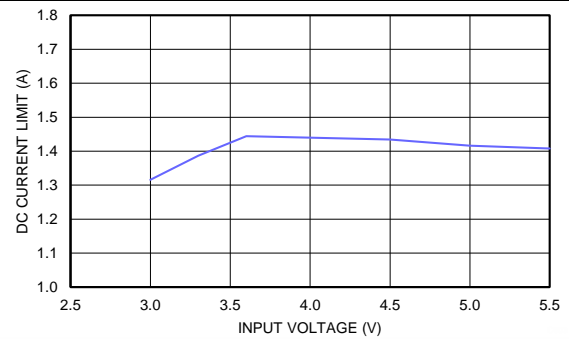

Figure 30. DC Current Limit $V_{OUT} = 2.5\text{ V}$, $T_A = 85^\circ\text{C}$

8.2.3.4 $V_{OUT} = 3.3\text{ V}$

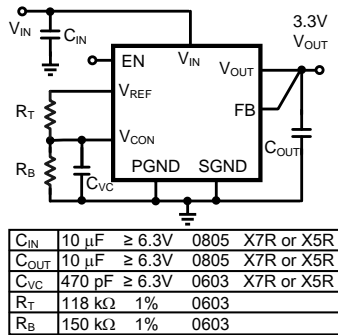

Figure 31. Schematic $V_{OUT} = 3.3\text{ V}$

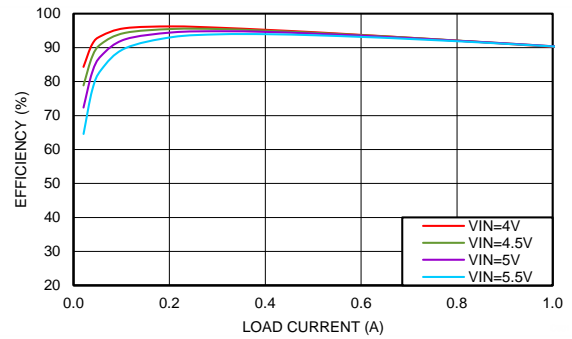

Figure 32. Efficiency $V_{OUT} = 3.3\text{ V}$

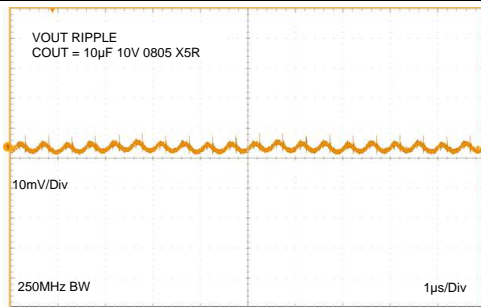

Figure 33. Output Ripple $V_{OUT} = 3.3\text{ V}$

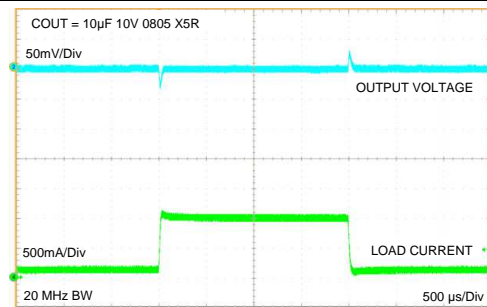

Figure 34. Load Transient $V_{OUT} = 3.3\text{ V}$

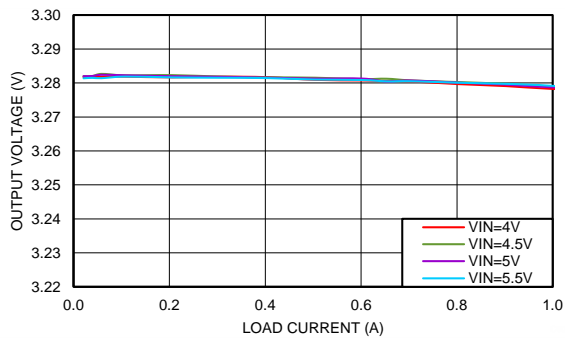

Figure 35. Line and Load Regulation $V_{OUT} = 3.3\text{ V}$

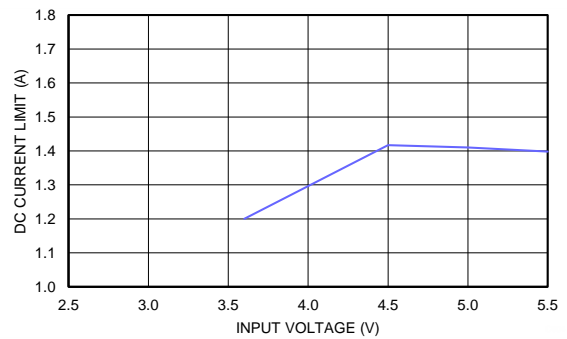

Figure 36. DC Current Limit $V_{OUT} = 3.3\text{ V}$, $T_A = 85^\circ\text{C}$

9 Power Supply Recommendations

9.1 Voltage Range

The voltage of the input supply must not exceed the *Absolute Maximum Ratings* and the *Recommended Operating Conditions* of the LMZ10501.

9.2 Current Capability

The input supply must be able to supply the required input current to the LMZ10501 converter. The required input current depends on the application's minimum required input voltage (V_{IN-MIN}), the required output power ($V_{OUT} \times I_{OUT-MAX}$), and the converter efficiency (η).

$$I_{IN} = V_{OUT} \times I_{OUT-MAX} / (V_{IN-MIN} \times \eta) \quad (6)$$

For example, for a design with 5-V minimum input voltage, 1.8-V output, and 1-A maximum load, considering 82% conversion efficiency, the required input current at steady state is 0.439A.

9.3 Input Connection

Long input connection cables can cause issues with the normal operation of any Buck converter.

9.3.1 Voltage Drops

Using long input wires to connect the supply to the input of any converter adds impedance in series with the input supply. This impedance can cause a voltage drop at the VIN pin of the converter when the output of the converter is loaded. If the input voltage is near the minimum operating voltage, this added voltage drop can cause the converter to drop out or reset. If long wires are used during testing, it is recommended to add some bulk (i.e. electrolytic) capacitance at the input of the converter.

9.3.2 Stability

The added inductance of long input cables together with the ceramic (and low ESR) input capacitor can result in an under damped RLC network at the input of the Buck converter. This can cause oscillations on the input and instability. If long wires are used, it is recommended to add some electrolytic capacitance in parallel with the ceramic input capacitor. The electrolytic capacitor's ESR will improve the damping.

Use an electrolytic capacitor with $C_{ELECTROLYTIC} \geq 4 \times C_{CERAMIC}$ and $ESR_{ELECTROLYTIC} \approx \sqrt{L_{CABLE} / C_{CERAMIC}}$

For example, two cables (one for VIN and one for GND), each 1 meter (~3ft) long with ~1.0mm diameter (18AWG), placed 1cm (~0.4in) apart will form a rectangular loop resulting in about 1.2μH of inductance. The inductance in this example can be decreased to almost half if the input wires are twisted. Based on a 10μF ceramic input capacitor, the recommended parallel $C_{ELECTROLYTIC}$ is $\geq 40 \mu F$. Using a 47μF capacitor will be sufficient. The recommended $ESR_{ELECTROLYTIC} \approx 0.35 \Omega$ or larger, based on about 1.2μH of inductance and 10μF of ceramic input capacitance.

See application note [SNVA489](#) for more details on input filter design.

10 Layout

10.1 Layout Guidelines

The board layout of any DC-DC switching converter is critical for the optimal performance of the design. Bad PCB layout design can disrupt the operation of an otherwise good schematic design. Even if the regulator still converts the voltage properly, the board layout can mean the difference between passing or failing EMI regulations. In a Buck converter, the most critical board layout path is between the input capacitor ground terminal and the synchronous rectifier ground. The loop formed by the input capacitor and the power FETs is a path for the high di/dt switching current during each switching period. This loop should always be kept as short as possible when laying out a board for any Buck converter.

The LMZ10501 integrates the inductor and simplifies the DC-DC converter board layout. Refer to the example layout in [Figure 37](#). There are a few basic requirements to achieve a good LMZ10501 layout.

1. Place the input capacitor C_{IN} as close as possible to the V_{IN} and PGND pins. V_{IN} (pin 7) and PGND (pin 6) on the LMZ10501 are next to each other which makes the input capacitor placement simple.
2. Place the V_{CON} filter capacitor C_{VC} and the R_B R_T resistive divider as close as possible to the V_{CON} and SGND pins. The C_{VC} capacitor (not R_B) should be the component closer to the V_{CON} pin, as shown in [Figure 37](#). This allows for better bypass of the control voltage set at V_{CON} .
3. Run the feedback trace (from V_{OUT} to FB) away from noise sources.
4. Connect SGND to a quiet GND plane.
5. Provide enough PCB area for proper heatsinking. Refer to the [Electrical Characteristics](#) table for example θ_{JA} values for different board areas. Also, refer to AN-2020 for additional thermal design hints.

Refer to the evaluation board user guide [SNVU313](#) for a complete board layout example.

10.2 Layout Example

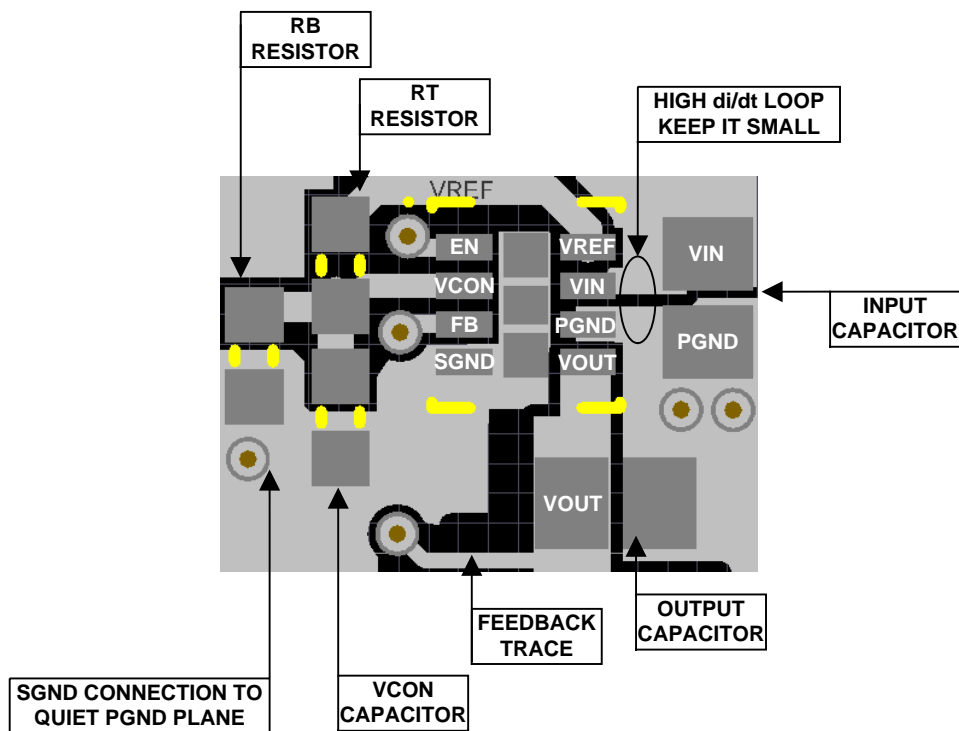

Figure 37. Example Top Layer Board Layout

10.3 Package Considerations

Use the following recommendations when utilizing machine placement :

- Use 1.06mm (42mil) or smaller nozzle size. The pick up area is the top of the inductor which is 1.6mm x 2mm.
- Soft tip pick and place nozzle is recommended.
- Add 0.05mm to the component thickness so that the device will be released 0.05mm (2mil) into the solder paste without putting pressure or splashing the solder paste.
- Slow the pick arm when picking the part from the tape and reel carrier and when depositing the IC on the board.
- If the machine releases the component by force, use minimum force or no more than 3 Newtons.

For manual placement:

- Use a vacuum pick up hand tool with soft tip head.
- If vacuum pick up tool is not available, use non-metal tweezers and hold the part by sides.
- Use minimal force when picking and placing the module on the board.
- Using hot air station provides better temperature control and better controlled air flow than a heat gun.
- Go to the video section at www.ti.com/product/lmz10501 for a quick video on how to solder rework the LMZ10501.

11 器件和文档支持

11.1 文档支持

11.1.1 相关文档

- 《AN-2162 轻松抑制 DC-DC 转换器中的传导性 EMI》，[SNVA489](#)
- 《MZ10501SIL 和 LMZ10500SIL SIMPLE SWITCHER® 纳米模块评估板》，[SNVU313](#)

11.2 商标

SIMPLE SWITCHER, WEBENCH are registered trademarks of Texas Instruments. All other trademarks are the property of their respective owners.

11.3 静电放电警告



这些装置包含有限的内置 ESD 保护。存储或装卸时，应将导线一起截短或将装置放置于导电泡棉中，以防止 MOS 门极遭受静电损伤。

11.4 Glossary

[SLYZ022](#) — *TI Glossary*.

This glossary lists and explains terms, acronyms, and definitions.

12 机械、封装和可订购信息

以下页中包括机械、封装和可订购信息。这些信息是针对指定器件可提供的最新数据。这些数据会在无通知且不对本文档进行修订的情况下发生改变。欲获得该数据表的浏览器版本，请查阅左侧的导航栏

重要声明

德州仪器(TI)及其下属子公司有权根据 JESD46 最新标准,对所提供的产品和服务进行更正、修改、增强、改进或其它更改,并有权根据 JESD48 最新标准中止提供任何产品和服务。客户在下订单前应获取最新的相关信息,并验证这些信息是否完整且是最新的。所有产品的销售都遵循在订单确认时所提供的TI 销售条款与条件。

TI 保证其所销售的组件的性能符合产品销售时 TI 半导体产品销售条件与条款的适用规范。仅在 TI 保证的范围内,且 TI 认为有必要时才会使用测试或其它质量控制技术。除非适用法律做出了硬性规定,否则没有必要对每种组件的所有参数进行测试。

TI 对应用帮助或客户产品设计不承担任何义务。客户应对其使用 TI 组件的产品和应用自行负责。为尽量减小与客户产品和应用相关的风险,客户应提供充分的设计与操作安全措施。

TI 不对任何 TI 专利权、版权、屏蔽作品权或其它与使用了 TI 组件或服务的组合设备、机器或流程相关的 TI 知识产权中授予的直接或隐含权限作出任何保证或解释。TI 所发布的与第三方产品或服务有关的信息,不能构成从 TI 获得使用这些产品或服务的许可、授权、或认可。使用此类信息可能需要获得第三方的专利权或其它知识产权方面的许可,或是 TI 的专利权或其它知识产权方面的许可。

对于 TI 的产品手册或数据表中 TI 信息的重要部分,仅在没有对内容进行任何篡改且带有相关授权、条件、限制和声明的情况下才允许进行复制。TI 对此类篡改过的文件不承担任何责任或义务。复制第三方的信息可能需要服从额外的限制条件。

在转售 TI 组件或服务时,如果对该组件或服务参数的陈述与 TI 标明的参数相比存在差异或虚假成分,则会失去相关 TI 组件或服务的所有明示或暗示授权,且这是不正当的、欺诈性商业行为。TI 对任何此类虚假陈述均不承担任何责任或义务。

客户认可并同意,尽管任何应用相关信息或支持仍可能由 TI 提供,但他们将独立负责满足与其产品及其在应用中使用的 TI 产品相关的所有法律、法规和安全相关要求。客户声明并同意,他们具备制定与实施安全措施所需的全部专业技术和知识,可预见故障的危险后果、监测故障及其后果、降低有可能造成人身伤害的故障的发生机率并采取适当的补救措施。客户将全额赔偿因在此类安全关键应用中使用任何 TI 组件而对 TI 及其代理造成的任何损失。

在某些场合中,为了推进安全相关应用有可能对 TI 组件进行特别的促销。TI 的目标是利用此类组件帮助客户设计和创立其特有的可满足适用的功能安全性标准和要求的终端产品解决方案。尽管如此,此类组件仍然服从这些条款。

TI 组件未获得用于 FDA Class III (或类似的生命攸关医疗设备)的授权许可,除非各方授权官员已经达成了专门管控此类使用的特别协议。



只有那些 TI 特别注明属于军用等级或“增强型塑料”的 TI 组件才是设计或专门用于军事/航空应用或环境的。购买者认可并同意,对并非指定面向军事或航空航天用途的 TI 组件进行军事或航空航天方面的应用,其风险由客户单独承担,并且由客户独立负责满足与此类使用相关的所有法律和法规要求。

TI 已明确指定符合 ISO/TS16949 要求的产品,这些产品主要用于汽车。在任何情况下,因使用非指定产品而无法达到 ISO/TS16949 要求, TI 不承担任何责任。

	产品		应用
数字音频	www.ti.com.cn/audio	通信与电信	www.ti.com.cn/telecom
放大器和线性器件	www.ti.com.cn/amplifiers	计算机及周边	www.ti.com.cn/computer
数据转换器	www.ti.com.cn/dataconverters	消费电子	www.ti.com.cn/consumer-apps
DLP® 产品	www.dlp.com	能源	www.ti.com.cn/energy
DSP - 数字信号处理器	www.ti.com.cn/dsp	工业应用	www.ti.com.cn/industrial
时钟和计时器	www.ti.com.cn/clockandtimers	医疗电子	www.ti.com.cn/medical
接口	www.ti.com.cn/interface	安防应用	www.ti.com.cn/security
逻辑	www.ti.com.cn/logic	汽车电子	www.ti.com.cn/automotive
电源管理	www.ti.com.cn/power	视频和影像	www.ti.com.cn/video
微控制器 (MCU)	www.ti.com.cn/microcontrollers		
RFID 系统	www.ti.com.cn/rfidsys		
OMAP应用处理器	www.ti.com/omap		
无线连通性	www.ti.com.cn/wirelessconnectivity	德州仪器在线技术支持社区	www.deyisupport.com

邮寄地址: 上海市浦东新区世纪大道1568号, 中建大厦32楼邮政编码: 200122
Copyright © 2016, 德州仪器半导体技术(上海)有限公司

PACKAGING INFORMATION

Orderable Device	Status (1)	Package Type	Package Drawing	Pins	Package Qty	Eco Plan (2)	Lead/Ball Finish (6)	MSL Peak Temp (3)	Op Temp (°C)	Device Marking (4/5)	Samples
LMZ10501SILR	ACTIVE	uSiP	SIL	8	3000	Green (RoHS & no Sb/Br)	Call TI	Level-3-260C-168 HR	-40 to 125	TXN5010EC (501 ~ DG) 9811 0501 0501 9811 DG	
LMZ10501SILT	ACTIVE	uSiP	SIL	8	250	Green (RoHS & no Sb/Br)	Call TI	Level-3-260C-168 HR	-40 to 125	TXN5010EC (501 ~ DG) 9811 0501 0501 9811 DG	

(1) The marketing status values are defined as follows:

ACTIVE: Product device recommended for new designs.

LIFEBUY: TI has announced that the device will be discontinued, and a lifetime-buy period is in effect.

NRND: Not recommended for new designs. Device is in production to support existing customers, but TI does not recommend using this part in a new design.

PREVIEW: Device has been announced but is not in production. Samples may or may not be available.

OBSOLETE: TI has discontinued the production of the device.

(2) Eco Plan - The planned eco-friendly classification: Pb-Free (RoHS), Pb-Free (RoHS Exempt), or Green (RoHS & no Sb/Br) - please check <http://www.ti.com/productcontent> for the latest availability information and additional product content details.

TBD: The Pb-Free/Green conversion plan has not been defined.

Pb-Free (RoHS): TI's terms "Lead-Free" or "Pb-Free" mean semiconductor products that are compatible with the current RoHS requirements for all 6 substances, including the requirement that lead not exceed 0.1% by weight in homogeneous materials. Where designed to be soldered at high temperatures, TI Pb-Free products are suitable for use in specified lead-free processes.

Pb-Free (RoHS Exempt): This component has a RoHS exemption for either 1) lead-based flip-chip solder bumps used between the die and package, or 2) lead-based die adhesive used between the die and leadframe. The component is otherwise considered Pb-Free (RoHS compatible) as defined above.

Green (RoHS & no Sb/Br): TI defines "Green" to mean Pb-Free (RoHS compatible), and free of Bromine (Br) and Antimony (Sb) based flame retardants (Br or Sb do not exceed 0.1% by weight in homogeneous material)

(3) MSL, Peak Temp. - The Moisture Sensitivity Level rating according to the JEDEC industry standard classifications, and peak solder temperature.

(4) There may be additional marking, which relates to the logo, the lot trace code information, or the environmental category on the device.

(5) Multiple Device Markings will be inside parentheses. Only one Device Marking contained in parentheses and separated by a "~" will appear on a device. If a line is indented then it is a continuation of the previous line and the two combined represent the entire Device Marking for that device.

(6) Lead/Ball Finish - Orderable Devices may have multiple material finish options. Finish options are separated by a vertical ruled line. Lead/Ball Finish values may wrap to two lines if the finish value exceeds the maximum column width.

Important Information and Disclaimer: The information provided on this page represents TI's knowledge and belief as of the date that it is provided. TI bases its knowledge and belief on information provided by third parties, and makes no representation or warranty as to the accuracy of such information. Efforts are underway to better integrate information from third parties. TI has taken and continues to take reasonable steps to provide representative and accurate information but may not have conducted destructive testing or chemical analysis on incoming materials and chemicals. TI and TI suppliers consider certain information to be proprietary, and thus CAS numbers and other limited information may not be available for release.

In no event shall TI's liability arising out of such information exceed the total purchase price of the TI part(s) at issue in this document sold by TI to Customer on an annual basis.

TAPE AND REEL INFORMATION

QUADRANT ASSIGNMENTS FOR PIN 1 ORIENTATION IN TAPE

*All dimensions are nominal

Device	Package Type	Package Drawing	Pins	SPQ	Reel Diameter (mm)	Reel Width W1 (mm)	A0 (mm)	B0 (mm)	K0 (mm)	P1 (mm)	W (mm)	Pin1 Quadrant
LMZ10501SILR	uSiP	SIL	8	3000	330.0	12.4	2.85	3.25	1.7	4.0	12.0	Q1

TAPE AND REEL BOX DIMENSIONS



*All dimensions are nominal

Device	Package Type	Package Drawing	Pins	SPQ	Length (mm)	Width (mm)	Height (mm)
LMZ10501SILR	uSiP	SIL	8	3000	383.0	353.0	58.0

有关 TI 设计信息和资源的重要通知

德州仪器 (TI) 公司提供的技术、应用或其他设计建议、服务或信息，包括但不限于与评估模块有关的参考设计和材料（总称“TI 资源”），旨在帮助设计人员开发整合了 TI 产品的应用；如果您（个人，或如果是代表贵公司，则为贵公司）以任何方式下载、访问或使用了任何特定的 TI 资源，即表示贵方同意仅为该等目标，按照本通知的条款进行使用。

TI 所提供的 TI 资源，并未扩大或以其他方式修改 TI 对 TI 产品的公开适用的质保及质保免责声明；也未导致 TI 承担任何额外的义务或责任。TI 有权对其 TI 资源进行纠正、增强、改进和其他修改。

您理解并同意，在设计应用时应自行实施独立的分析、评价和判断，且应全权负责并确保应用的安全性，以及您的应用（包括应用中使用的 TI 产品）应符合所有适用的法律法规及其他相关要求。您就您的应用声明，您具备制订和实施下列保障措施所需的一切必要专业知识，能够 (1) 预见故障的危险后果，(2) 监视故障及其后果，以及 (3) 降低可能导致危险的故障几率并采取适当措施。您同意，在使用或分发包含 TI 产品的任何应用前，您将彻底测试该等应用和该等应用所用 TI 产品的功能。除特定 TI 资源的公开文档中明确列出的测试外，TI 未进行任何其他测试。

您只有在为开发包含该等 TI 资源所列 TI 产品的应用时，才被授权使用、复制和修改任何相关单项 TI 资源。但并未依据禁止反言原则或其他法律授予您任何 TI 知识产权的任何其他明示或默示的许可，也未授予您 TI 或第三方的任何技术或知识产权的许可，该等产权包括但不限于任何专利权、版权、屏蔽作品权或与使用 TI 产品或服务的任何整合、机器制作、流程相关的其他知识产权。涉及或参考了第三方产品或服务的信息不构成使用此类产品或服务的许可或与其相关的保证或认可。使用 TI 资源可能需要您向第三方获得对该等第三方专利或其他知识产权的许可。

TI 资源系“按原样”提供。TI 兹免除对 TI 资源及其使用作出所有其他明确或默示的保证或陈述，包括但不限于对准确性或完整性、产权保证、无复发故障保证，以及适销性、适合特定用途和不侵犯任何第三方知识产权的任何默认保证。

TI 不负责任何申索，包括但不限于因组合产品所致或与之有关的申索，也不为您辩护或赔偿，即使该等产品组合已列于 TI 资源或其他地方。对因 TI 资源或其使用引起或与之有关的任何实际的、直接的、特殊的、附带的、间接的、惩罚性的、偶发的、从属或惩戒性损害赔偿，不管 TI 是否获悉可能会产生上述损害赔偿，TI 概不负责。

您同意向 TI 及其代表全额赔偿因您不遵守本通知条款和条件而引起的任何损害、费用、损失和/或责任。

本通知适用于 TI 资源。另有其他条款适用于某些类型的材料、TI 产品和服务的使用和采购。这些条款包括但不限于适用于 TI 的半导体产品 (<http://www.ti.com/sc/docs/stdterms.htm>)、[评估模块](http://www.ti.com/sc/docs/sampters.htm)和样品 (<http://www.ti.com/sc/docs/sampters.htm>) 的标准条款。

邮寄地址：上海市浦东新区世纪大道 1568 号中建大厦 32 楼，邮政编码：200122
Copyright © 2017 德州仪器半导体技术（上海）有限公司