

LMV331 SINGLE, LMV393 DUAL, LMV339 QUAD GENERAL-PURPOSE LOW-VOLTAGE COMPARATORS

SLCS136K – AUGUST 1999 – REVISED FEBRUARY 2004

- **2.7-V and 5-V Performance**
- **Low Supply Current:**
 LMV331 . . . 60 μ A Typ
 LMV393 . . . 100 μ A Typ
 LMV339 . . . 170 μ A Typ
- **Input Common-Mode Voltage Range Includes Ground**
- **Low Output Saturation Voltage . . . 200 mV Typ**
- **Open-Collector Output for Maximum Flexibility**

description/ordering information

The LMV393 and LMV339 devices are low-voltage (2.7 V to 5.5 V) versions of the dual and quad comparators, LM393 and LM339, which operate from 5 V to 30 V. The LMV331 is the single-comparator version.

The LMV331, LMV339, and LMV393 are the most cost-effective solutions for applications where low-voltage operation, low power, space saving, and price are the primary specifications in circuit design for portable consumer products. These devices offer specifications that meet or exceed the familiar LM339 and LM393 devices at a fraction of the supply current.

LMV339 . . . D OR PW PACKAGE
(TOP VIEW)

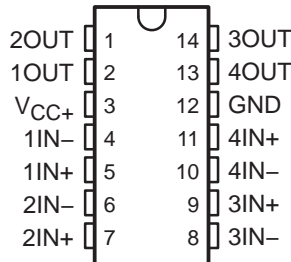

LMV393 . . . D, DGK, OR PW PACKAGE
(TOP VIEW)

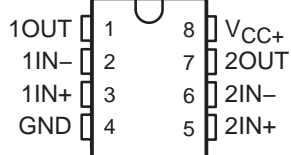

LMV331 . . . DBV OR DCK PACKAGE
(TOP VIEW)

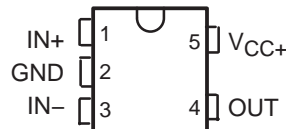

ORDERING INFORMATION

T _A		PACKAGE†		ORDERABLE PART NUMBER	TOP-SIDE MARKING‡
-40°C to 85°C	Single	SC-70 (DCK)	Reel of 3000	LMV331DCKR	R2_
			Reel of 250	LMV331DCKT	
		SOT23-5 (DBV)	Reel of 3000	LMV331DBVR	R11_
			Reel of 250	LMV331DBVT	
	Dual	MSOP/VSSOP (DGK)	Reel of 2500	LMV393DGKR	R9R
			Tube of 75	LMV393ID	
		SOIC (D)	Reel of 2500	LMV393IDR	MV393I
			Tube of 90	LMV393IPW	
		TSSOP (PW)	Reel of 2000	LMV393IPWR	MV393I
			Tube of 150	LMV393IPW	
	Quad	SOIC (D)	Tube of 50	LMV339ID	LMV339I
			Reel of 2500	LMV339IDR	
TSSOP (PW)		Tube of 150	LMV339IPW	MV339I	
		Reel of 2000	LMV339IPWR		

† Package drawings, standard packing quantities, thermal data, symbolization, and PCB design guidelines are available at www.ti.com/sc/package.

‡ DBV/DCK: The actual top-side marking has one additional character that designates the assembly/test site.



Please be aware that an important notice concerning availability, standard warranty, and use in critical applications of Texas Instruments semiconductor products and disclaimers thereto appears at the end of this data sheet.

PRODUCTION DATA information is current as of publication date. Products conform to specifications per the terms of Texas Instruments standard warranty. Production processing does not necessarily include testing of all parameters.

 **TEXAS
INSTRUMENTS**

POST OFFICE BOX 655303 • DALLAS, TEXAS 75265

Copyright © 2004, Texas Instruments Incorporated

LMV331 SINGLE, LMV393 DUAL, LMV339 QUAD GENERAL-PURPOSE LOW-VOLTAGE COMPARATORS

SLCS136K – AUGUST 1999 – REVISED FEBRUARY 2004

symbol (each comparator)

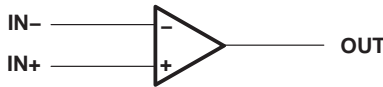

simplified schematic

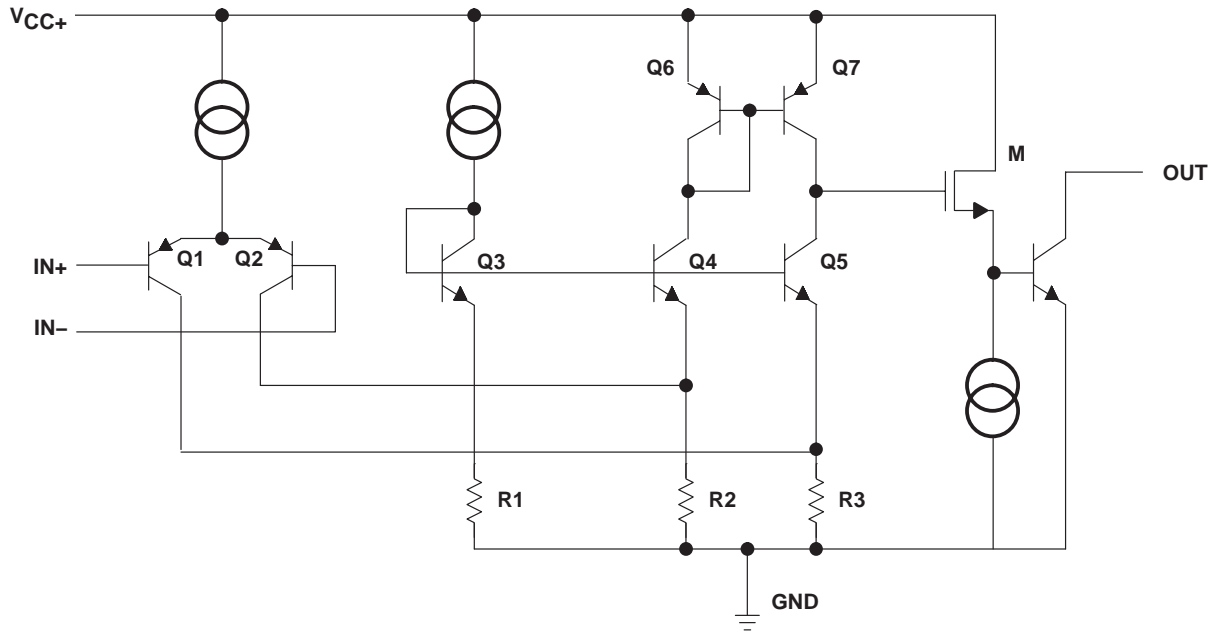

absolute maximum ratings over operating free-air temperature range (unless otherwise noted)†

Supply voltage, V_{CC+} (see Note 1)	5.5 V
Differential input voltage, V_{ID} (see Note 2)	± 5.5 V
Input voltage range, V_I (either input)	0 V to 5.5 V
Package thermal impedance, θ_{JA} (see Notes 3 and 4):	
D (8-pin) package	97°C/W
D (14-pin) package	86°C/W
DBV package	206°C/W
DCK package	252°C/W
DGK package	172°C/W
PW (8-pin) package	149°C/W
PW (14-pin) package	113°C/W
Operating virtual junction temperature, T_J	150°C
Storage temperature range, T_{stg}	-65°C to 150°C

† Stresses beyond those listed under “absolute maximum ratings” may cause permanent damage to the device. These are stress ratings only, and functional operation of the device at these or any other conditions beyond those indicated under “recommended operating conditions” is not implied. Exposure to absolute-maximum-rated conditions for extended periods may affect device reliability.

- NOTES:
1. All voltage values (except differential voltages and V_{CC+} specified for the measurement of I_{OS}) are with respect to the network GND.
 2. Differential voltages are at $IN+$ with respect to $IN-$.
 3. Maximum power dissipation is a function of $T_J(\max)$, θ_{JA} , and T_A . The maximum allowable power dissipation at any allowable ambient temperature is $P_D = (T_J(\max) - T_A)/\theta_{JA}$. Selecting the maximum of 150°C can affect reliability.
 4. The package thermal impedance is calculated in accordance with JESD 51-7.

LMV331 SINGLE, LMV393 DUAL, LMV339 QUAD GENERAL-PURPOSE LOW-VOLTAGE COMPARATORS

SLCS136K – AUGUST 1999 – REVISED FEBRUARY 2004

recommended operating conditions

	MIN	MAX	UNIT
V _{CC+} Supply voltage (single-supply operation)	2.7	5.5	V
V _{OUT} Output voltage	V _{CC+} + 0.3		V
T _A Operating free-air temperature	-40	85	°C

electrical characteristics at specified free-air temperature, V_{CC+} = 2.7 V, GND = 0 V (unless otherwise noted)

PARAMETER	TEST CONDITIONS	T _A	MIN	TYP	MAX	UNIT
V _{IO} Input offset voltage		25°C		1.7	7	mV
α _{V_{IO}} Average temperature coefficient of input offset voltage		-40°C to 85°C		5		μV/°C
I _{IB} Input bias current		25°C		10	250	nA
		-40°C to 85°C			400	
I _{IO} Input offset current		25°C		5	50	nA
		-40°C to 85°C			150	
I _O Output current (sinking)	V _O ≤ 1.5 V	25°C	5	23		mA
Output leakage current		25°C		0.003		μA
		-40°C to 85°C			1	
V _{ICR} Common-mode input voltage range		25°C	-0.1 to 2			V
V _{SAT} Saturation voltage	I _O ≤ 1 mA	25°C		200		mV
I _{CC} Supply current	LMV331	25°C		40	100	μA
	LMV393 (both comparators)	25°C		70	140	
	LMV339 (all four comparators)	25°C		140	200	

switching characteristics, T_A = 25°C, V_{CC+} = 2.7 V, R_L = 5.1 kΩ, GND = 0 V (unless otherwise noted)

PARAMETER	TEST CONDITIONS	TYP	UNIT
t _{PHL} Propagation delay, high- to low-level output switching	Input overdrive = 10 mV	1000	ns
	Input overdrive = 100 mV	350	
t _{PLH} Propagation delay, low- to high-level output switching	Input overdrive = 10 mV	500	ns
	Input overdrive = 100 mV	400	



LMV331 SINGLE, LMV393 DUAL, LMV339 QUAD GENERAL-PURPOSE LOW-VOLTAGE COMPARATORS

SLCS136K – AUGUST 1999 – REVISED FEBRUARY 2004

electrical characteristics at specified free-air temperature, $V_{CC+} = 5\text{ V}$, $GND = 0\text{ V}$ (unless otherwise noted)

PARAMETER		TEST CONDITIONS	T_A	MIN	TYP	MAX	UNIT
V_{IO}	Input offset voltage		25°C		1.7	7	mV
			-40°C to 85°C			9	
$\alpha_{V_{IO}}$	Average temperature coefficient of input offset voltage		25°C		5		$\mu\text{V}/^\circ\text{C}$
I_{IB}	Input bias current		25°C		25	250	nA
			-40°C to 85°C			400	
I_{IO}	Input offset current		25°C		2	50	nA
			-40°C to 85°C			150	
I_O	Output current (sinking)	$V_O \leq 1.5\text{ V}$	25°C	10	84		mA
	Output leakage current		25°C		0.003		μA
			-40°C to 85°C			1	
V_{ICR}	Common-mode input voltage range		25°C	-0.1 to 4.2			V
A_{VD}	Large-signal differential voltage gain		25°C	20	50		V/mV
V_{SAT}	Saturation voltage	$I_O \leq 4\text{ mA}$	25°C		200	400	mV
			-40°C to 85°C			700	
I_{CC}	Supply current	LMV331	25°C		60	120	μA
			-40°C to 85°C			150	
		LMV393 (both comparators)	25°C		100	200	
			-40°C to 85°C			250	
		LMV339 (all four comparators)	25°C		170	300	
			-40°C to 85°C			350	

switching characteristics, $T_A = 25^\circ\text{C}$, $V_{CC+} = 5\text{ V}$, $R_L = 5.1\text{ k}\Omega$, $GND = 0\text{ V}$ (unless otherwise noted)

PARAMETER		TEST CONDITIONS	TYP	UNIT
t_{PHL}	Propagation delay, high- to low-level output switching	Input overdrive = 10 mV	600	ns
		Input overdrive = 100 mV	200	
t_{PLH}	Propagation delay, low- to high-level output switching	Input overdrive = 10 mV	450	ns
		Input overdrive = 100 mV	300	



DBV (R-PDSO-G5)

PLASTIC SMALL-OUTLINE PACKAGE

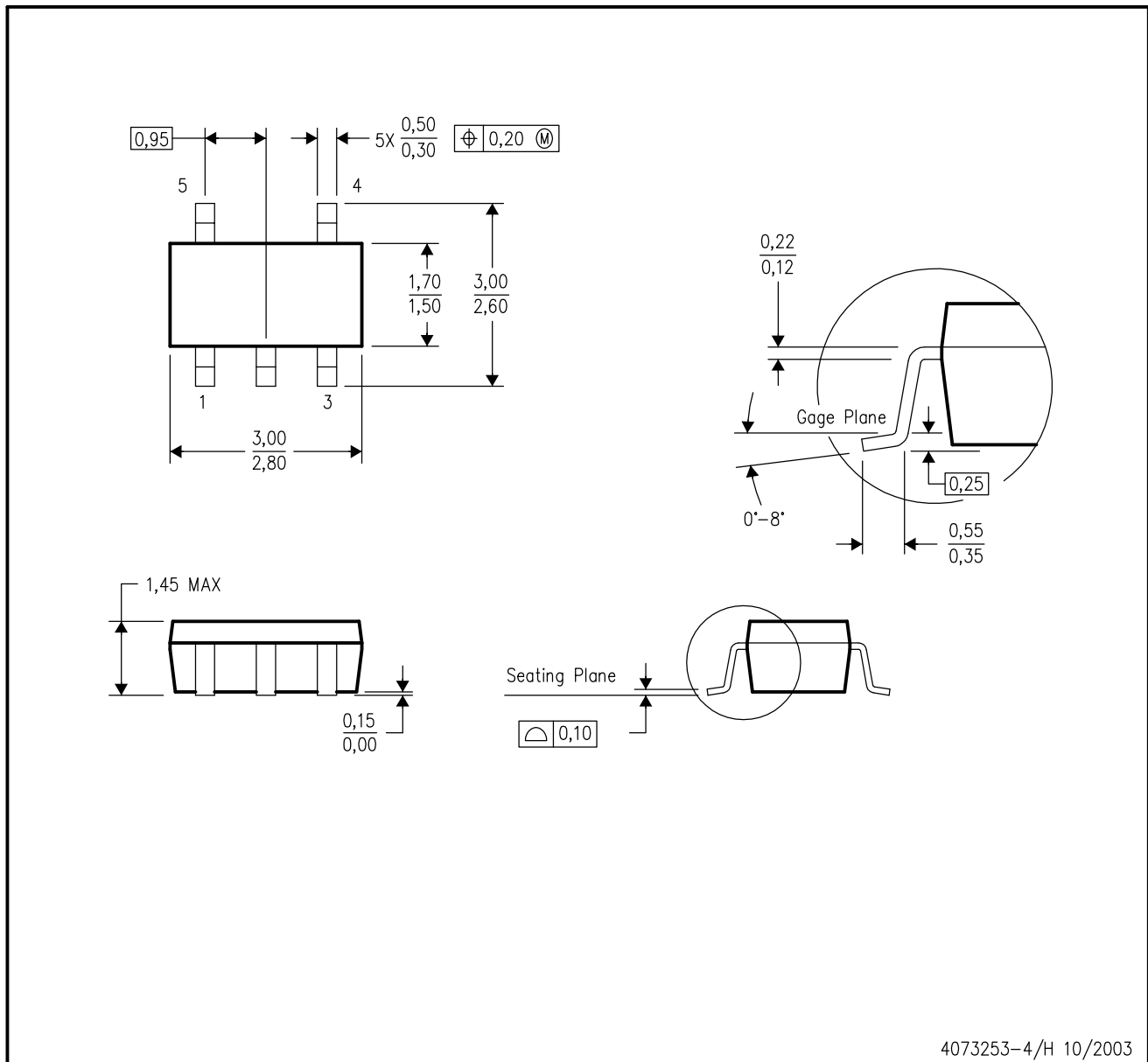

- NOTES:
- A. All linear dimensions are in millimeters.
 - B. This drawing is subject to change without notice.
 - C. Body dimensions do not include mold flash or protrusion.
 - D. Falls within JEDEC MO-178 Variation AA.

DCK (R-PDSO-G5)

PLASTIC SMALL-OUTLINE PACKAGE

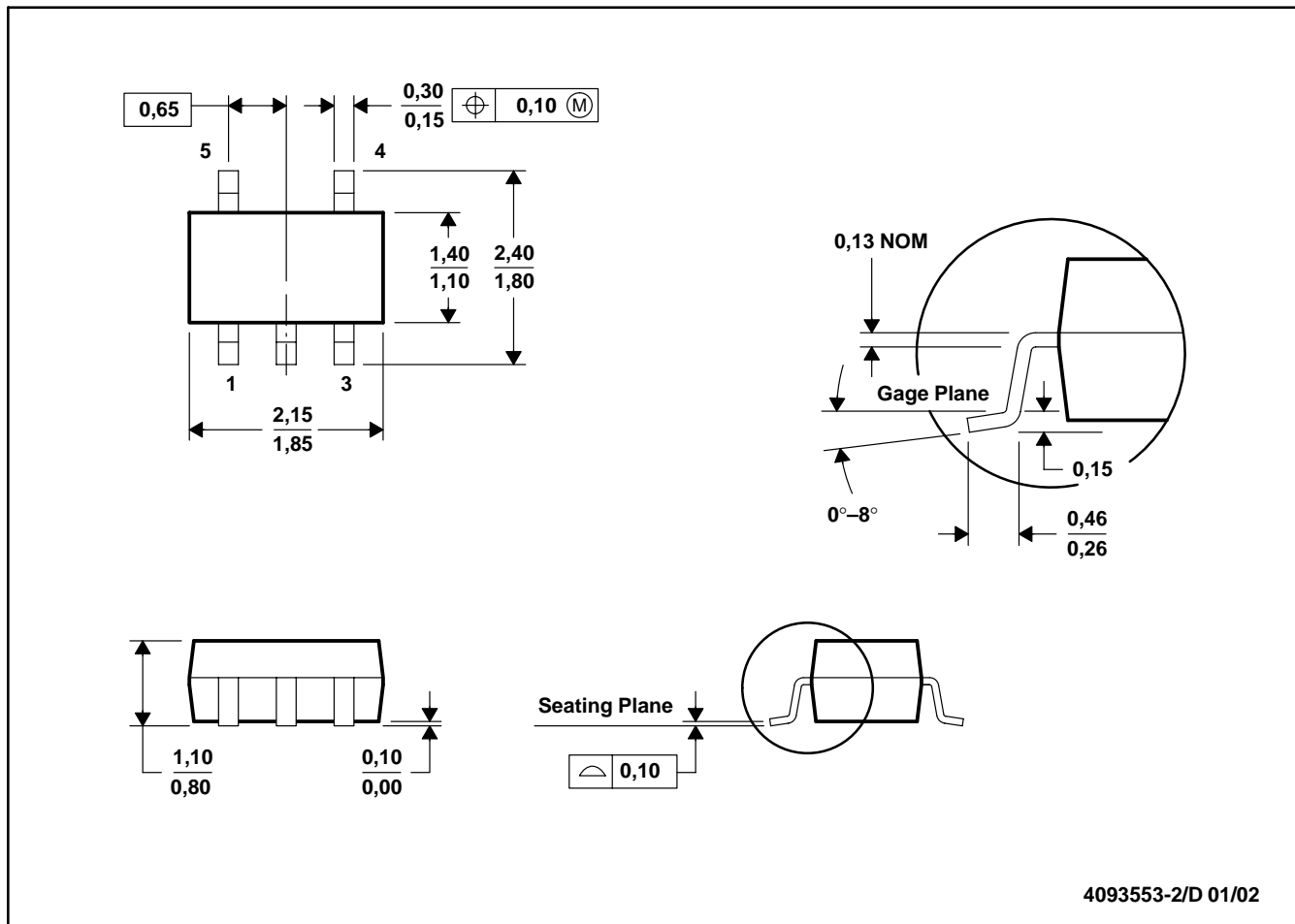

4093553-2/D 01/02

- NOTES:
- A. All linear dimensions are in millimeters.
 - B. This drawing is subject to change without notice.
 - C. Body dimensions do not include mold flash or protrusion.
 - D. Falls within JEDEC MO-203

DGK (S-PDSO-G8)

PLASTIC SMALL-OUTLINE PACKAGE

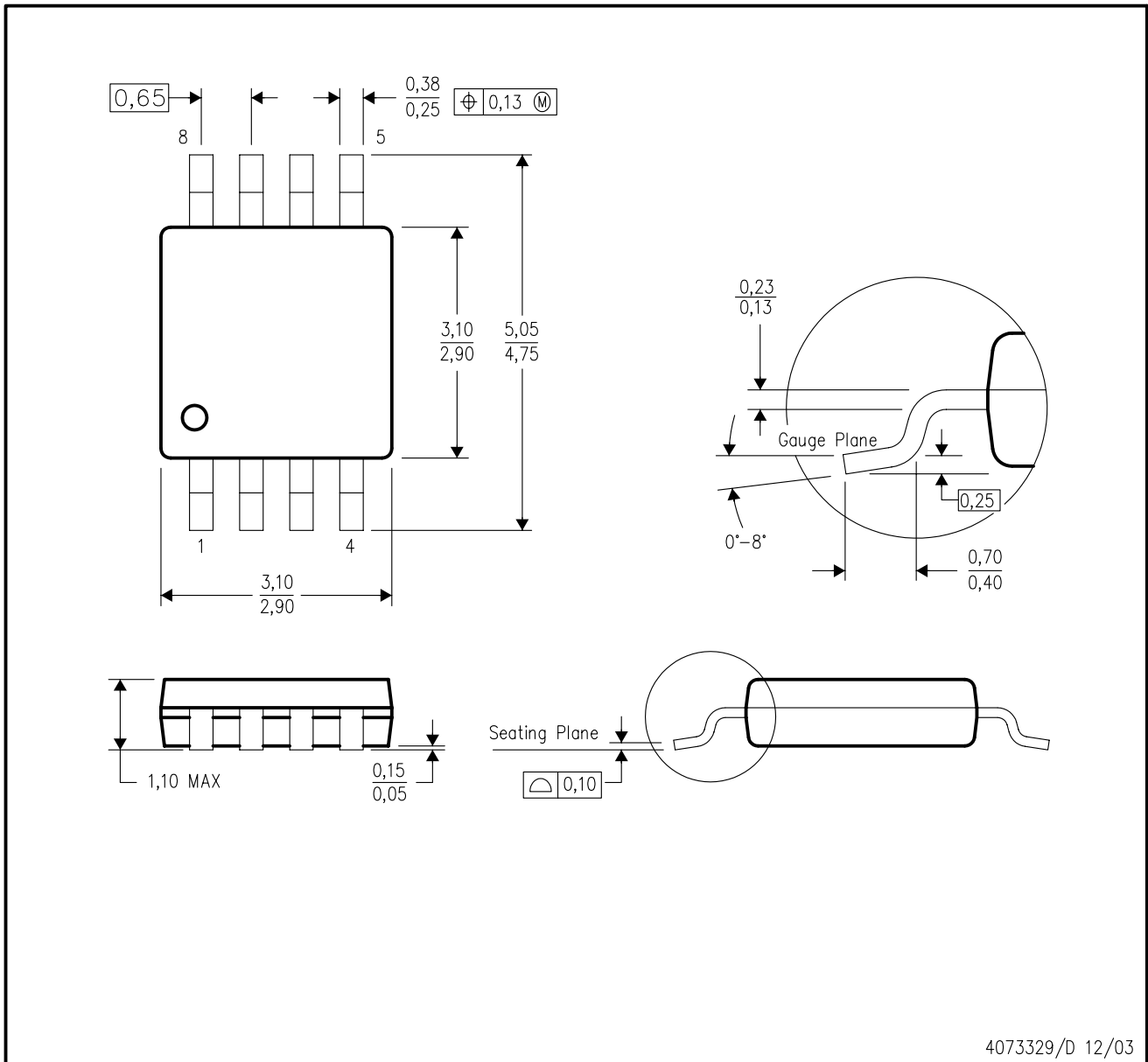

- NOTES:
- A. All linear dimensions are in millimeters.
 - B. This drawing is subject to change without notice.
 - C. Body dimensions do not include mold flash or protrusion.
 - D. Falls within JEDEC MO-187 variation AA.

D (R-PDSO-G**)

PLASTIC SMALL-OUTLINE PACKAGE

8 PINS SHOWN

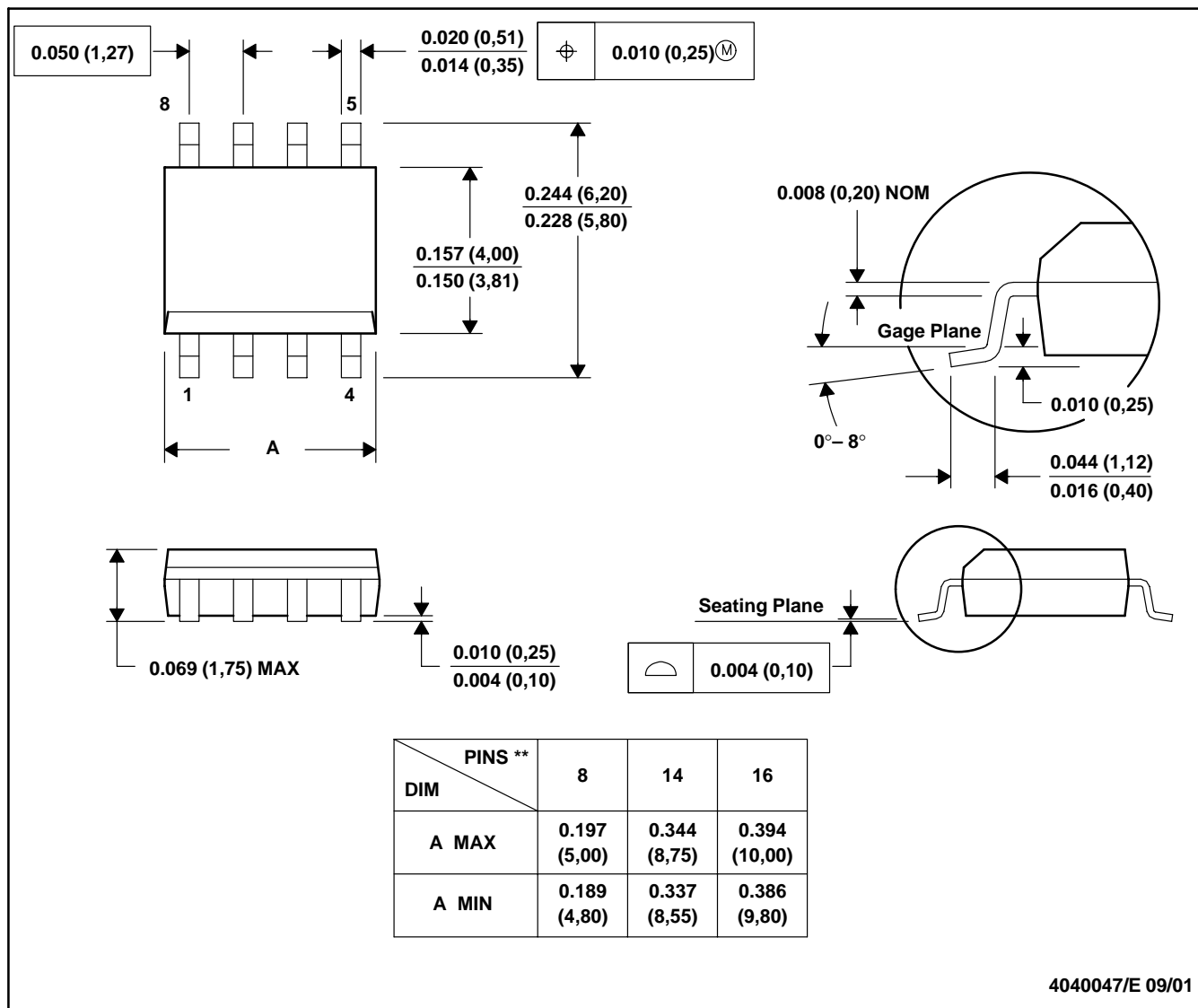

- NOTES: A. All linear dimensions are in inches (millimeters).
 B. This drawing is subject to change without notice.
 C. Body dimensions do not include mold flash or protrusion, not to exceed 0.006 (0,15).
 D. Falls within JEDEC MS-012

PW (R-PDSO-G**)

PLASTIC SMALL-OUTLINE PACKAGE

14 PINS SHOWN



4040064/F 01/97

- NOTES: A. All linear dimensions are in millimeters.
 B. This drawing is subject to change without notice.
 C. Body dimensions do not include mold flash or protrusion not to exceed 0,15.
 D. Falls within JEDEC MO-153

IMPORTANT NOTICE

Texas Instruments Incorporated and its subsidiaries (TI) reserve the right to make corrections, modifications, enhancements, improvements, and other changes to its products and services at any time and to discontinue any product or service without notice. Customers should obtain the latest relevant information before placing orders and should verify that such information is current and complete. All products are sold subject to TI's terms and conditions of sale supplied at the time of order acknowledgment.

TI warrants performance of its hardware products to the specifications applicable at the time of sale in accordance with TI's standard warranty. Testing and other quality control techniques are used to the extent TI deems necessary to support this warranty. Except where mandated by government requirements, testing of all parameters of each product is not necessarily performed.

TI assumes no liability for applications assistance or customer product design. Customers are responsible for their products and applications using TI components. To minimize the risks associated with customer products and applications, customers should provide adequate design and operating safeguards.

TI does not warrant or represent that any license, either express or implied, is granted under any TI patent right, copyright, mask work right, or other TI intellectual property right relating to any combination, machine, or process in which TI products or services are used. Information published by TI regarding third-party products or services does not constitute a license from TI to use such products or services or a warranty or endorsement thereof. Use of such information may require a license from a third party under the patents or other intellectual property of the third party, or a license from TI under the patents or other intellectual property of TI.

Reproduction of information in TI data books or data sheets is permissible only if reproduction is without alteration and is accompanied by all associated warranties, conditions, limitations, and notices. Reproduction of this information with alteration is an unfair and deceptive business practice. TI is not responsible or liable for such altered documentation.

Resale of TI products or services with statements different from or beyond the parameters stated by TI for that product or service voids all express and any implied warranties for the associated TI product or service and is an unfair and deceptive business practice. TI is not responsible or liable for any such statements.

Following are URLs where you can obtain information on other Texas Instruments products and application solutions:

Products		Applications	
Amplifiers	amplifier.ti.com	Audio	www.ti.com/audio
Data Converters	dataconverter.ti.com	Automotive	www.ti.com/automotive
DSP	dsp.ti.com	Broadband	www.ti.com/broadband
Interface	interface.ti.com	Digital Control	www.ti.com/digitalcontrol
Logic	logic.ti.com	Military	www.ti.com/military
Power Mgmt	power.ti.com	Optical Networking	www.ti.com/opticalnetwork
Microcontrollers	microcontroller.ti.com	Security	www.ti.com/security
		Telephony	www.ti.com/telephony
		Video & Imaging	www.ti.com/video
		Wireless	www.ti.com/wireless

Mailing Address: Texas Instruments
Post Office Box 655303 Dallas, Texas 75265