

Distributed by:

**JAMECO**<sup>®</sup>  
ELECTRONICS

**www.Jameco.com ♦ 1-800-831-4242**

The content and copyrights of the attached  
material are the property of its owner.

Jameco Part Number 903197

# LMC555 CMOS Timer

## General Description

The LMC555 is a CMOS version of the industry standard 555 series general purpose timers. In addition to the standard package (SOIC, MSOP, and MDIP) the LMC555 is also available in a chip sized package (8 Bump micro SMD) using National's micro SMD package technology. The LMC555 offers the same capability of generating accurate time delays and frequencies as the LM555 but with much lower power dissipation and supply current spikes. When operated as a one-shot, the time delay is precisely controlled by a single external resistor and capacitor. In the stable mode the oscillation frequency and duty cycle are accurately set by two external resistors and one capacitor. The use of National Semiconductor's LMCOS™ process extends both the frequency range and low supply capability.

## Features

- Less than 1 mW typical power dissipation at 5V supply
- 3 MHz astable frequency capability
- 1.5V supply operating voltage guaranteed
- Output fully compatible with TTL and CMOS logic at 5V supply
- Tested to -10 mA, +50 mA output current levels
- Reduced supply current spikes during output transitions
- Extremely low reset, trigger, and threshold currents
- Excellent temperature stability
- Pin-for-pin compatible with 555 series of timers
- Available in 8-pin MSOP Package and 8-Bump micro SMD package

## Pulse Width Modulator

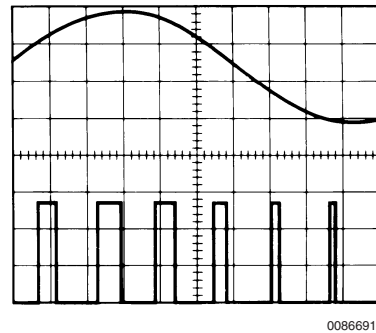
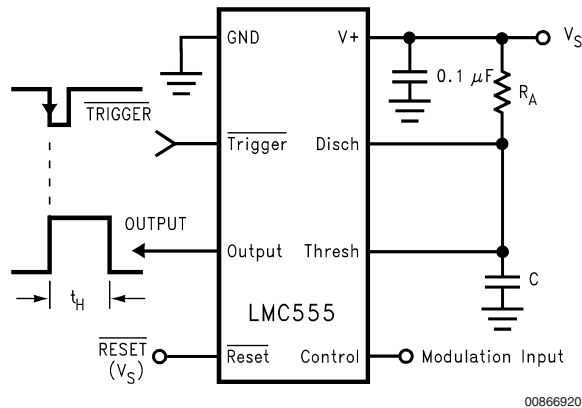

00866915

00866920

## Ordering Information

Package	Temperature Range	Package Marking	Transport Media	NSC Drawing
	Industrial -40°C to +85°C			
8-Pin Small Outline (SO)	LMC555CM	LMC555CM	Rails	M08A
	LMC555CMX		2.5k Units Tape and Reel	
8-Pin Mini Small Outline (MSOP)	LMC555CMM	ZC5	1k Units Tape and Reel	MUA08A
	LMC555CMMX		3.5k Units Tape and Reel	
8-Pin Molded Dip (MDIP)	LMC555CN	LMC555CN	Rails	N08E
8-Bump micro SMD	LMC555CBP	F1	250 Units Tape and Reel	BPA08EFB
	LMC555CBPX		3k Units Tape and Reel	
8-Bump micro SMD NOPB	LMC555CTP	F02	250 Units Tape and Reel	TPA08EFA
	LMC555CTPX		3k Units Tape and Reel	

**Note:** See Mil-datasheet MNL555-X for specifications on the military device LMC555J/883.

LMCMOS™ is a trademark of National Semiconductor Corp.

# Connection Diagrams

8-Pin SOIC, MSOP, MDIP

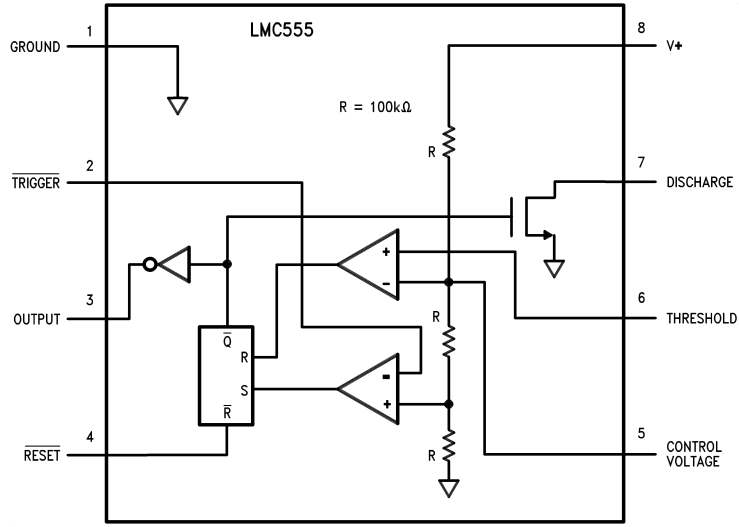

00866901

Top View

8-Bump micro SMD

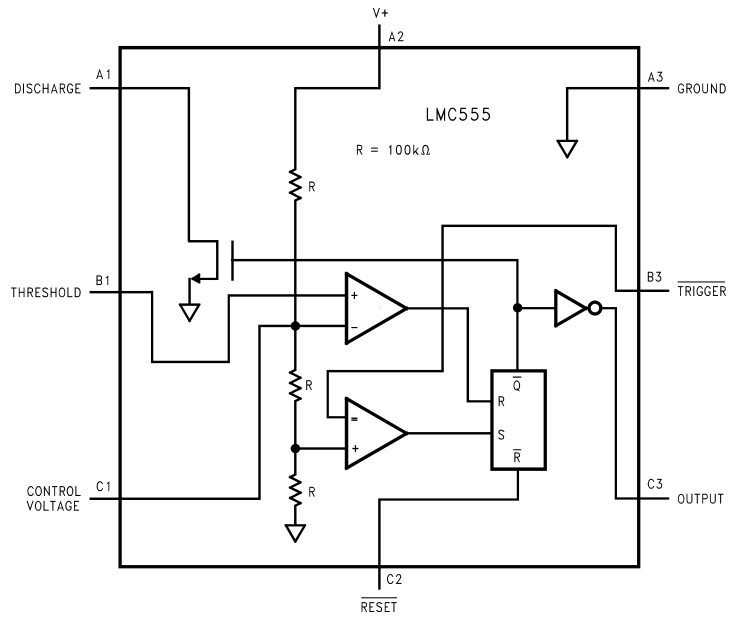

00866909

Top View  
(Bump Side Down)

**Absolute Maximum Ratings** (Notes 2, 3)

If Military/Aerospace specified devices are required, please contact the National Semiconductor Sales Office/Distributors for availability and specifications.

Supply Voltage, $V^+$	15V
Input Voltages, $V_{TRIG}$ , $V_{RES}$ , $V_{CTRL}$	
$V_{THRESH}$	-0.3V to $V_S + 0.3V$
Output Voltages, $V_O$ , $V_{DIS}$	15V
Output Current $I_O$ , $I_{DIS}$	100 mA
Storage Temperature Range	-65°C to +150°C
Soldering Information	
MDIP Soldering (10 seconds)	260°C
SOIC, MSOP Vapor Phase (60 sec)	215°C
SOIC, MSOP Infrared (15 sec)	220°C

**Note:** See AN-450 "Surface Mounting Methods and Their Effect on Product Reliability" for other methods of soldering surface mount devices.

**Operating Ratings** (Notes 2, 3)

Temperature Range	-40°C to +85°C
-------------------	----------------

**Electrical Characteristics** (Notes 1, 2)

Test Circuit,  $T = 25^\circ\text{C}$ , all switches open,  $\overline{\text{RESET}}$  to  $V_S$  unless otherwise noted

Thermal Resistance ( $\theta_{JA}$ ) (Note 2)

SO, 8-Pin Small Outline	169°C/W
MSOP, 8-Pin Mini Small Outline	225°C/W
MDIP, 8-Pin Molded Dip	111°C/W
8-Bump micro SMD	220°C/W
Maximum Allowable Power Dissipation @25°C	
MDIP-8	1126 mW
SO-8	740 mW
MSOP-8	555 mW
8 Bump micro SMD	568 mW

Symbol	Parameter	Conditions	Min	Typ	Max	Units (Limits)
$I_S$	Supply Current	$V_S = 1.5V$ $V_S = 5V$ $V_S = 12V$		50 100 150	150 250 400	$\mu\text{A}$
$V_{CTRL}$	Control Voltage	$V_S = 1.5V$ $V_S = 5V$ $V_S = 12V$	0.8 2.9 7.4	1.0 3.3 8.0	1.2 3.8 8.6	V
$V_{DIS}$	Discharge Saturation Voltage	$V_S = 1.5V$ , $I_{DIS} = 1 \text{ mA}$ $V_S = 5V$ , $I_{DIS} = 10 \text{ mA}$		75 150	150 300	mV
$V_{OL}$	Output Voltage (Low)	$V_S = 1.5V$ , $I_O = 1 \text{ mA}$ $V_S = 5V$ , $I_O = 8 \text{ mA}$ $V_S = 12V$ , $I_O = 50 \text{ mA}$		0.2 0.3 1.0	0.4 0.6 2.0	V
$V_{OH}$	Output Voltage (High)	$V_S = 1.5V$ , $I_O = -0.25 \text{ mA}$ $V_S = 5V$ , $I_O = -2 \text{ mA}$ $V_S = 12V$ , $I_O = -10 \text{ mA}$	1.0 4.4 10.5	1.25 4.7 11.3		V
$V_{TRIG}$	Trigger Voltage	$V_S = 1.5V$ $V_S = 12V$	0.4 3.7	0.5 4.0	0.6 4.3	V
$I_{TRIG}$	Trigger Current	$V_S = 5V$		10		pA
$V_{RES}$	Reset Voltage	$V_S = 1.5V$ (Note 4) $V_S = 12V$	0.4 0.4	0.7 0.75	1.0 1.1	V
$I_{RES}$	Reset Current	$V_S = 5V$		10		pA
$I_{THRESH}$	Threshold Current	$V_S = 5V$		10		pA
$I_{DIS}$	Discharge Leakage	$V_S = 12V$		1.0	100	nA
t	Timing Accuracy	SW 2, 4 Closed $V_S = 1.5V$ $V_S = 5V$ $V_S = 12V$	0.9 1.0 1.0	1.1 1.1 1.1	1.25 1.20 1.25	ms
$\Delta t/\Delta V_S$	Timing Shift with Supply	$V_S = 5V \pm 1V$		0.3		%/V

# Electrical Characteristics (Notes 1, 2)

Test Circuit, T = 25°C, all switches open,  $\overline{\text{RESET}}$  to  $V_S$  unless otherwise noted (Continued)

Symbol	Parameter	Conditions	Min	Typ	Max	Units (Limits)
$\Delta t/\Delta T$	Timing Shift with Temperature	$V_S = 5V$ $-40^\circ\text{C} \leq T \leq +85^\circ\text{C}$		75		ppm/°C
$f_A$	Astable Frequency	SW 1, 3 Closed, $V_S = 12V$	4.0	4.8	5.6	kHz
$f_{MAX}$	Maximum Frequency	Max. Freq. Test Circuit, $V_S = 5V$		3.0		MHz
$t_R, t_F$	Output Rise and Fall Times	Max. Freq. Test Circuit $V_S = 5V, C_L = 10\text{ pF}$		15		ns
$t_{PD}$	Trigger Propagation Delay	$V_S = 5V$ , Measure Delay from Trigger to Output		100		ns

**Note 1:** All voltages are measured with respect to the ground pin, unless otherwise specified.

**Note 2:** Absolute Maximum Ratings indicate limits beyond which damage to the device may occur. Operating Ratings indicate conditions for which the device is functional, but do not guarantee specific performance limits. Electrical Characteristics state DC and AC electrical specifications under particular test conditions which guarantee specific performance limits. This assumes that the device is within the Operating Ratings. Specifications are not guaranteed for parameters where no limit is given, however, the typical value is a good indication of device performance.

**Note 3:** See AN-450 for other methods of soldering surface mount devices, and also AN-1112 for micro SMD considerations.

**Note 4:** If the  $\overline{\text{RESET}}$  pin is to be used at temperatures of  $-20^\circ\text{C}$  and below  $V_S$  is required to be 2.0V or greater.

**Note 5:** For device pinout please refer to table 1

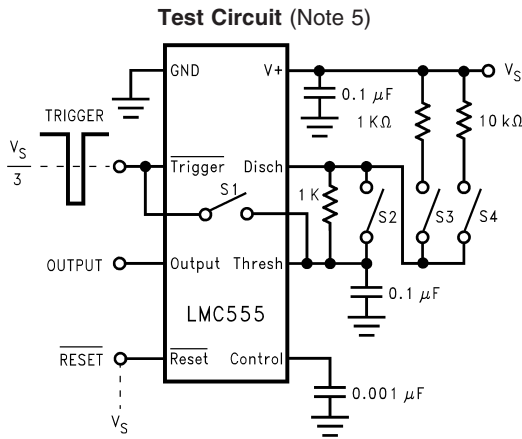

00866902

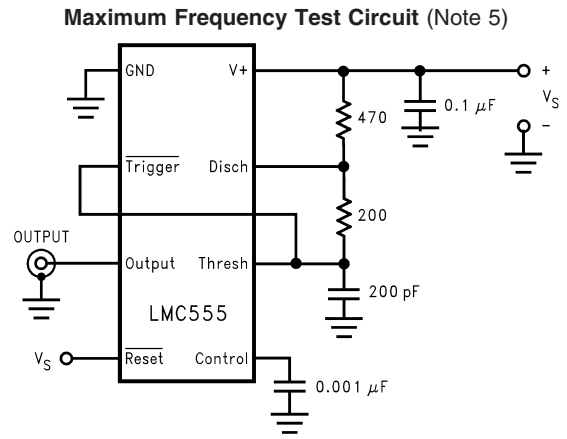

00866903

TABLE 1. Package Pinout Names vs. Pin Function

Pin Function	Package Pin numbers	
	8-Pin SO, MSOP, and MDIP	8-Bump micro SMD
GND	1	A3
Trigger	2	B3
Output	3	C3
Reset	4	C2
Control Voltage	5	C1
Threshold	6	B1
Discharge	7	A1
V+	8	A2

# Application Information

## MONOSTABLE OPERATION

In this mode of operation, the timer functions as a one-shot (Figure 1). The external capacitor is initially held discharged by internal circuitry. Upon application of a negative trigger pulse of less than  $1/3 V_S$  to the  $\overline{\text{Trigger}}$  terminal, the flip-flop is set which both releases the short circuit across the capacitor and drives the output high.

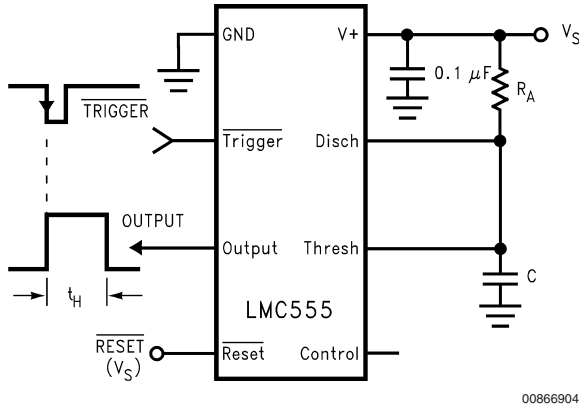
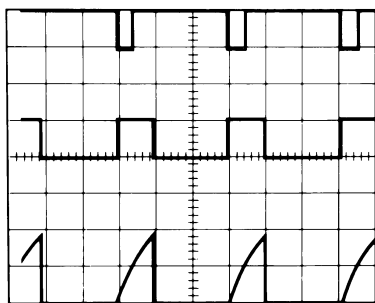

FIGURE 1. Monostable (One-Shot)

The voltage across the capacitor then increases exponentially for a period of  $t_H = 1.1 R_A C$ , which is also the time that the output stays high, at the end of which time the voltage equals  $2/3 V_S$ . The comparator then resets the flip-flop which in turn discharges the capacitor and drives the output to its low state. Figure 2 shows the waveforms generated in this mode of operation. Since the charge and the threshold level of the comparator are both directly proportional to supply voltage, the timing internal is independent of supply.



$V_{CC} = 5V$   
 TIME = 0.1 ms/Div. Top Trace: Input 5 V/Div.  
 $R_A = 9.1 k\Omega$  Middle Trace: Output 5 V/Div.  
 $C = 0.01 \mu F$  Bottom Trace: Capacitor Voltage 2 V/Div.

FIGURE 2. Monostable Waveforms

Reset overrides Trigger, which can override threshold. Therefore the trigger pulse must be shorter than the desired  $t_H$ . The minimum pulse width for the Trigger is 20ns, and it is 400ns for the Reset. During the timing cycle when the output is high, the further application of a trigger pulse will not effect the circuit so long as the trigger input is returned high at least 10μs before the end of the timing interval. However the circuit can be reset during this time by the application of a

negative pulse to the reset terminal. The output will then remain in the low state until a trigger pulse is again applied. When the reset function is not use, it is recommended that it be connected to  $V_+$  to avoid any possibility of false triggering. Figure 3 is a nomograph for easy determination of RC values for various time delays.

Note: In monstable operation, the trigger should be driven high before the end of timing cycle.

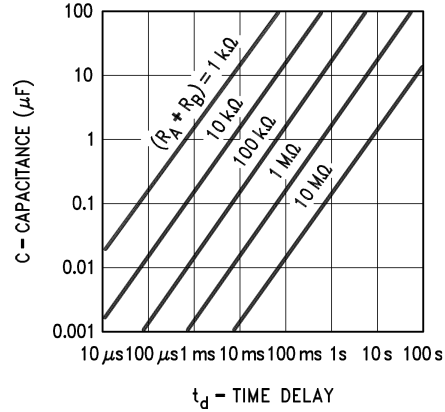

FIGURE 3. Time Delay

## ASTABLE OPERATION

If the circuit is connected as shown in Figure 4 ( $\overline{\text{Trigger}}$  and Threshold terminals connected together) it will trigger itself and free run as a multivibrator. The external capacitor charges through  $R_A + R_B$  and discharges through  $R_B$ . Thus the duty cycle may be precisely set by the ratio of these two resistors.

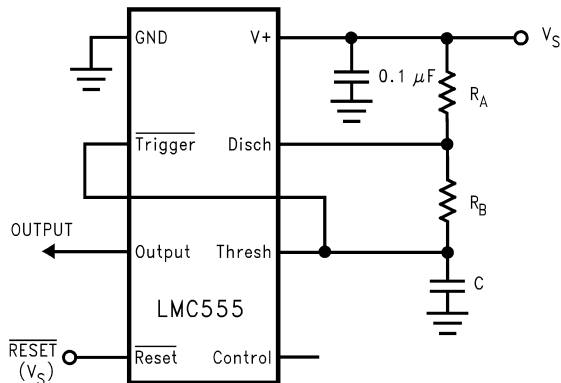
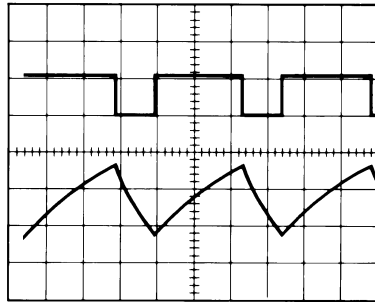

FIGURE 4. Astable (Variable Duty Cycle Oscillator)

In this mode of operation, the capacitor charges and discharges between  $1/3 V_S$  and  $2/3 V_S$ . As in the triggered mode, the charge and discharge times, and therefore the frequency are independent of the supply voltage.

Figure 5 shows the waveform generated in this mode of operation.

## Application Information (Continued)



00866912

$V_{CC} = 5V$  Top Trace: Output 5 V/Div.  
 TIME = 20  $\mu s$ /Div. Bottom Trace: Capacitor Voltage 1 V/Div.  
 $R_A = 3.9 k\Omega$   
 $R_B = 9 k\Omega$   
 $C = 0.01 \mu F$

**FIGURE 5. Astable Waveforms**

The charge time (output high) is given by

$$t_1 = 0.693 (R_A + R_B)C$$

And the discharge time (output low) by:

$$t_2 = 0.693 (R_B)C$$

Thus the total period is:

$$T = t_1 + t_2 = 0.693 (R_A + 2R_B)C$$

The frequency of oscillation is:

$$f = \frac{1}{T} = \frac{1.44}{(R_A + 2R_B)C}$$

Figure 6 may be used for quick determination of these RC Values. The duty cycle, as a fraction of total period that the output is low, is:

$$D = \frac{R_B}{R_A + 2R_B}$$

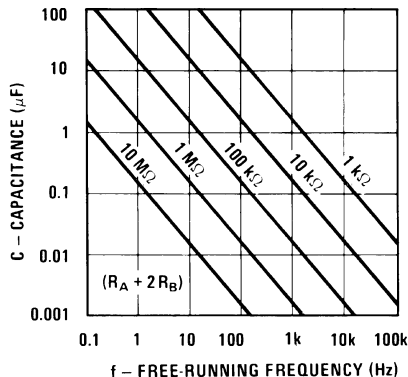

00866913

**FIGURE 6. Free Running Frequency**

## FREQUENCY DIVIDER

The monostable circuit of Figure 1 can be used as a frequency divider by adjusting the length of the timing cycle. Figure 7 shows the waveforms generated in a divide by three circuit.

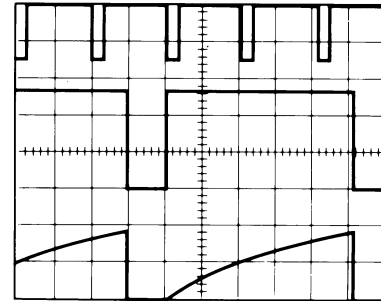

00866914

$V_{CC} = 5V$  Top Trace: Input 4 V/Div.  
 TIME = 20  $\mu s$ /Div. Middle Trace: Output 2 V/Div.  
 $R_A = 9.1 k\Omega$  Bottom Trace: Capacitor 2 V/Div.  
 $C = 0.01 \mu F$

**FIGURE 7. Frequency Divider Waveforms**

## PULSE WIDTH MODULATOR

When the timer is connected in the monostable mode and triggered with a continuous pulse train, the output pulse width can be modulated by a signal applied to the Control Voltage Terminal. Figure 8 shows the circuit, and in Figure 9 are some waveform examples.

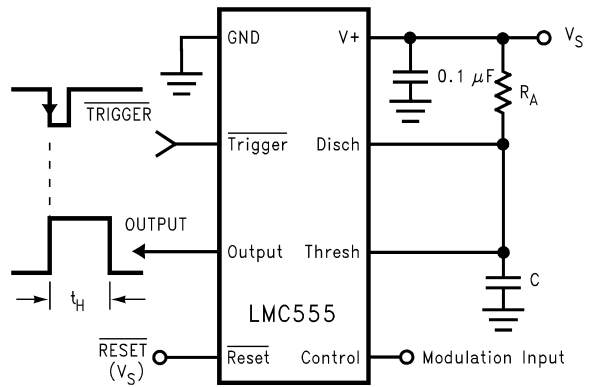

00866920

**FIGURE 8. Pulse Width Modulator**

**Application Information** (Continued)

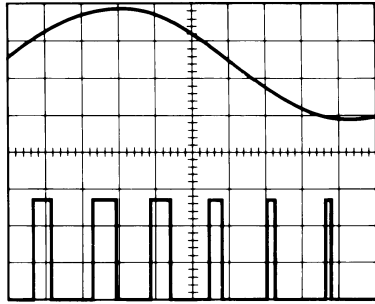

00866915  
 $V_{CC} = 5V$  Top Trace: Modulation 1 V/Div.  
 TIME = 0.2 ms/Div. Bottom Trace: Output Voltage 2 V/Div.  
 $R_A = 9.1 k\Omega$   
 $C = 0.01 \mu F$

**FIGURE 9. Pulse Width Modulator Waveforms**

**PULSE POSITION MODULATOR**

This application uses the timer connected for astable operation, as in *Figure 10*, with a modulating signal again applied to the control voltage terminal. The pulse position varies with the modulating signal, since the threshold voltage and hence the time delay is varied. *Figure 11* shows the waveforms generated for a triangle wave modulation signal.

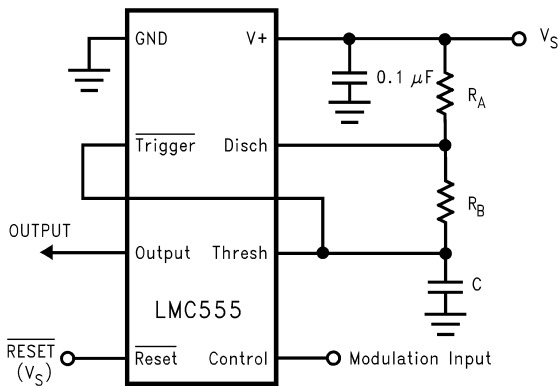

**FIGURE 10. Pulse Position Modulator**

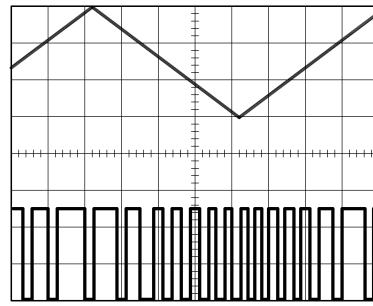

00866916  
 $V_{CC} = 5V$  Top Trace: Modulation Input 1 V/Div.  
 TIME = 0.1 ms/Div. Bottom Trace: Output Voltage 2 V/Div.  
 $R_A = 3.9 k\Omega$   
 $R_B = 3 k\Omega$   
 $C = 0.01 \mu F$

**FIGURE 11. Pulse Position Modulator Waveforms**

**50% DUTY CYCLE OSCILLATOR**

The frequency of oscillation is  
 $f = 1/(1.4 R_C C)$

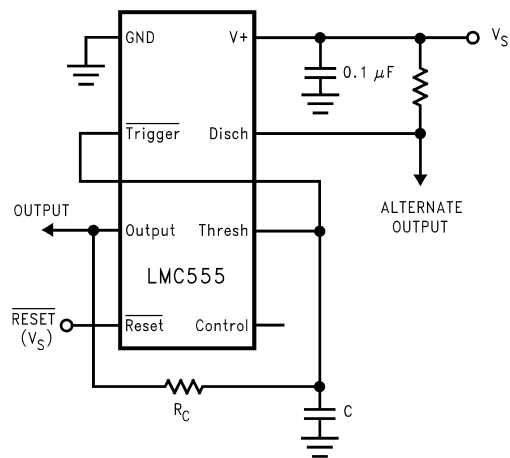

**FIGURE 12. 50% Duty Cycle Oscillator**

**micro SMD Marking Orientation  
 Top View**

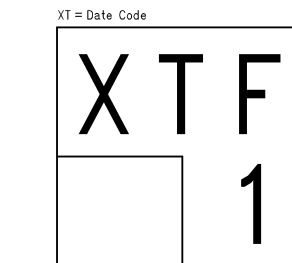

Pin A1 Corner  
 Pin A1 is identified by lower left corner with respect to the text.

Bumps are numbered counter-clockwise

00866923

**Physical Dimensions** inches (millimeters) unless otherwise noted

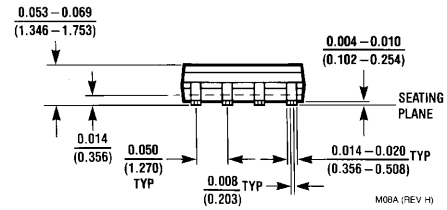
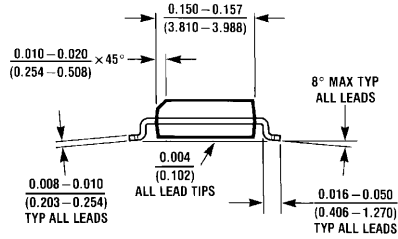
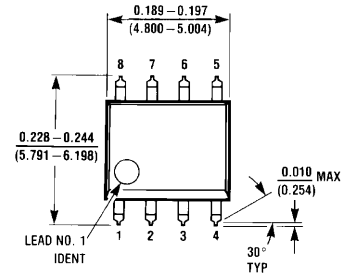

**Molded Small Outline (SO) Package (M)**  
**NS Package Number M08A**

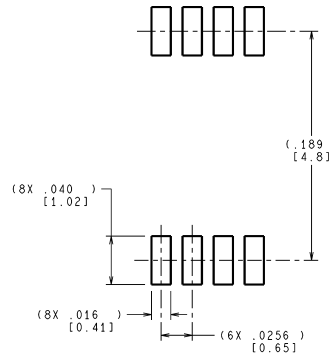
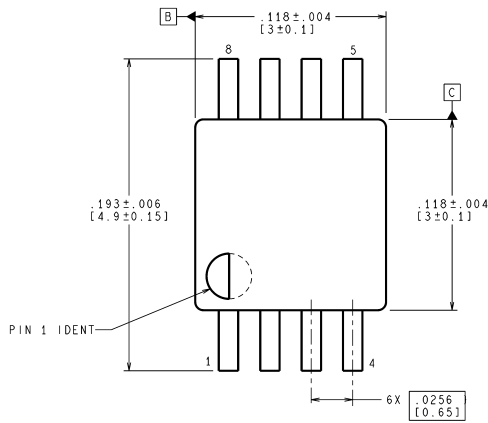

**LAND PATTERN RECOMMENDATION**

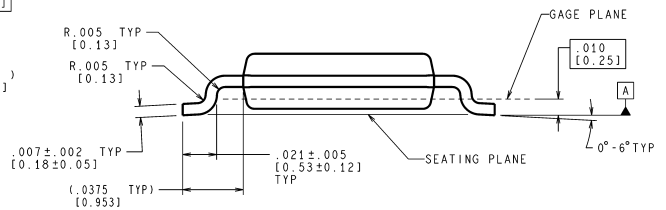
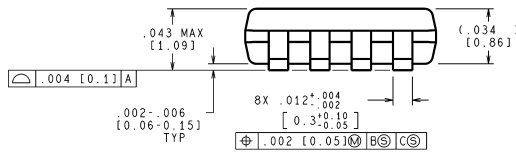

CONTROLLING DIMENSION IS INCH  
VALUES IN [ ] ARE MILLIMETERS

MUA08A (Rev E)

**8-Pin (0.118" Wide) Molded Mini Small Outline Package**  
**NS Package Number MUA08A**

**Physical Dimensions** inches (millimeters) unless otherwise noted (Continued)

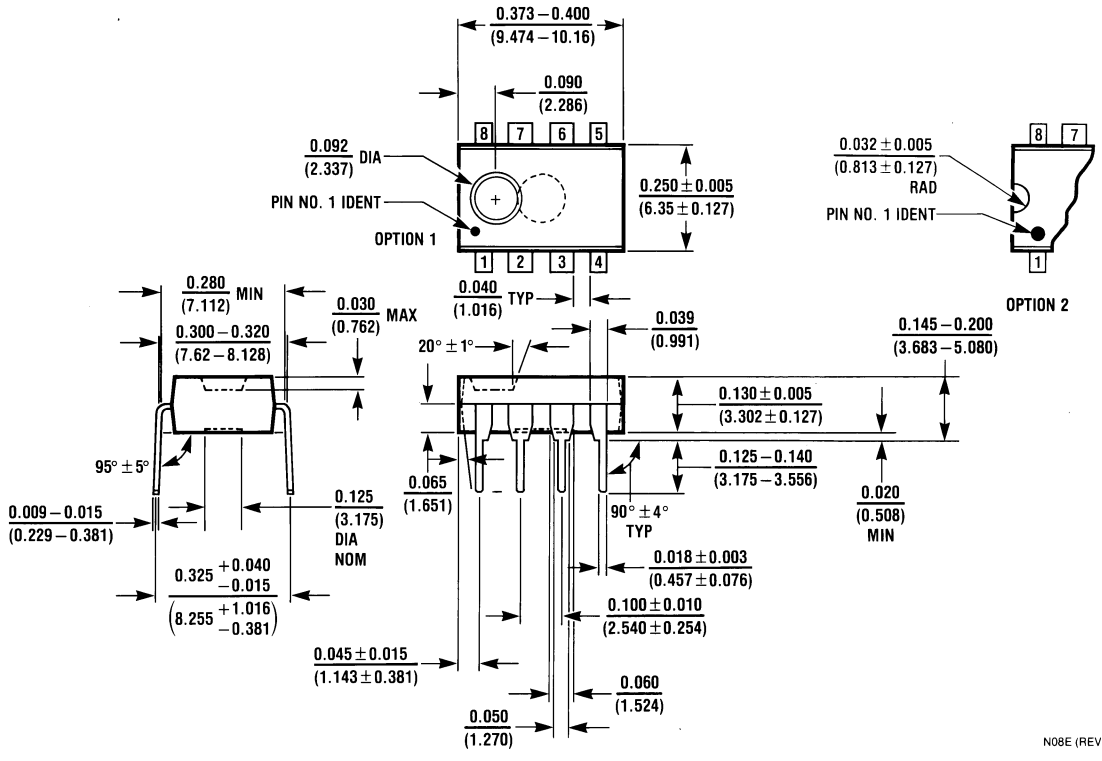

**Molded Dual-in-line Package (N)**  
NS Package Number N08E

N08E (REV F)

**Physical Dimensions** inches (millimeters) unless otherwise noted (Continued)

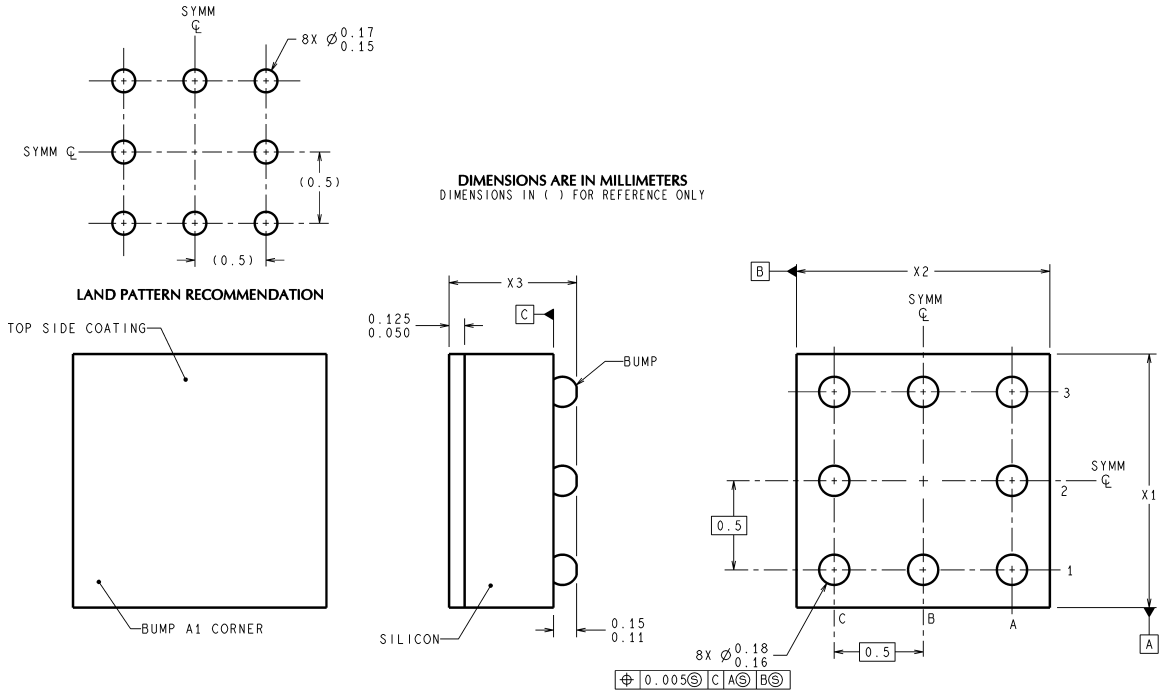

NOTES: UNLESS OTHERWISE SPECIFIED

1. EPOXY COATING
2. 63Sn/37Pb EUTECTIC BUMP
3. RECOMMEND NON-SOLDER MASK DEFINED LANDING PAD.
4. PIN A1 IS ESTABLISHED BY LOWER LEFT CORNER WITH RESPECT TO TEXT ORIENTATION. REMAINING PINS ARE NUMBERED COUNTERCLOCKWISE.
5. XXX IN DRAWING NUMBER REPRESENTS PACKAGE SIZE VARIATION WHERE X1 IS PACKAGE WIDTH, X2 IS PACKAGE LENGTH AND X3 IS PACKAGE HEIGHT.
6. REFERENCE JEDEC REGISTRATION MO-211, VARIATION BC.

**8-Bump micro SMD Package**  
**NS Package Number BPA08EFB**  
**X<sub>1</sub> = 1.387 X<sub>2</sub> = 1.412 X<sub>3</sub> = 0.850**

**Physical Dimensions** inches (millimeters) unless otherwise noted (Continued)

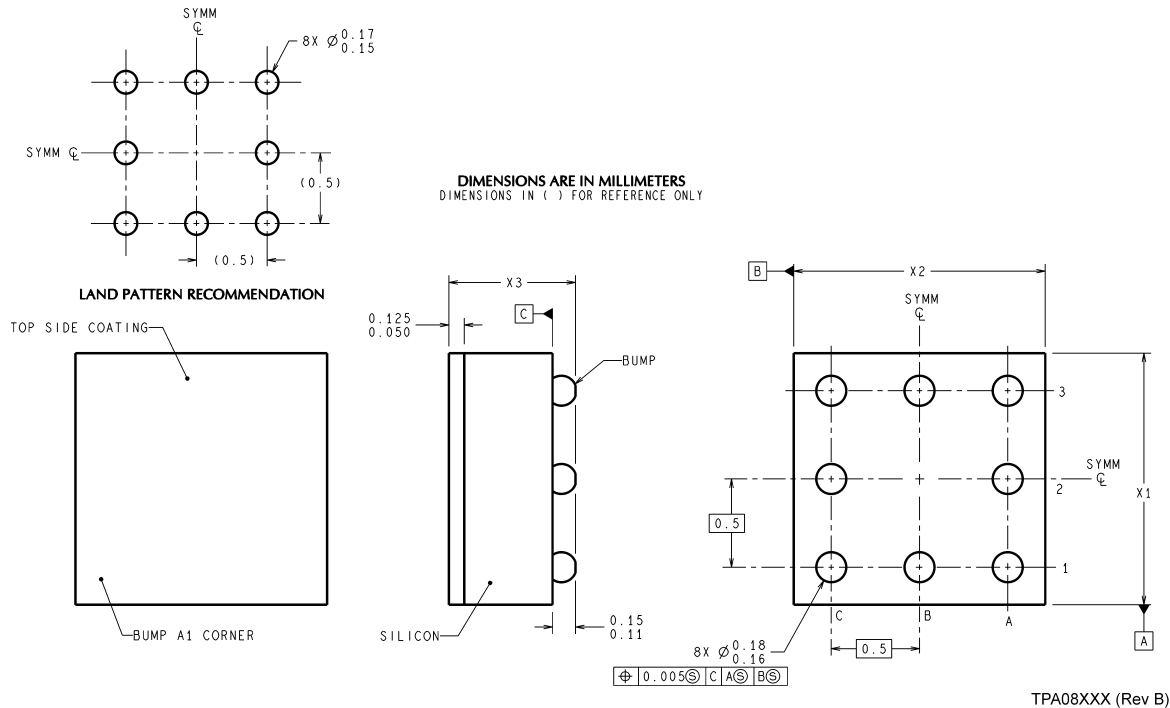

NOTES: UNLESS OTHERWISE SPECIFIED

1. EPOXY COATING
2. FOR SOLDER BUMP COMPOSITION, SEE "SOLDER INFORMATION" IN THE PACKAGING SECTION OF THE NATIONAL SEMICONDUCTOR WEB PAGE ([www.national.com](http://www.national.com)).
3. RECOMMEND NON-SOLDER MASK DEFINED LANDING PAD.
4. PIN A1 IS ESTABLISHED BY LOWER LEFT CORNER WITH RESPECT TO TEXT ORIENTATION.
5. XXX IN DRAWING NUMBER REPRESENTS PACKAGE SIZE VARIATION WHERE X1 IS PACKAGE WIDTH, X2 IS PACKAGE LENGTH AND X3 IS PACKAGE HEIGHT.
6. REFERENCE JEDEC REGISTRATION MO-211, VARIATION BC.

**8-Bump micro SMD Package**  
**NS Package Number TPA08EFA**  
**X<sub>1</sub> = 1.387 X<sub>2</sub> = 1.412 X<sub>3</sub> = 0.500**

National does not assume any responsibility for use of any circuitry described, no circuit patent licenses are implied and National reserves the right at any time without notice to change said circuitry and specifications.

For the most current product information visit us at [www.national.com](http://www.national.com).

**LIFE SUPPORT POLICY**

NATIONAL'S PRODUCTS ARE NOT AUTHORIZED FOR USE AS CRITICAL COMPONENTS IN LIFE SUPPORT DEVICES OR SYSTEMS WITHOUT THE EXPRESS WRITTEN APPROVAL OF THE PRESIDENT AND GENERAL COUNSEL OF NATIONAL SEMICONDUCTOR CORPORATION. As used herein:

1. Life support devices or systems are devices or systems which, (a) are intended for surgical implant into the body, or (b) support or sustain life, and whose failure to perform when properly used in accordance with instructions for use provided in the labeling, can be reasonably expected to result in a significant injury to the user.
2. A critical component is any component of a life support device or system whose failure to perform can be reasonably expected to cause the failure of the life support device or system, or to affect its safety or effectiveness.

**BANNED SUBSTANCE COMPLIANCE**

National Semiconductor follows the provisions of the Product Stewardship Guide for Customers (CSP-9-111C2) and Banned Substances and Materials of Interest Specification (CSP-9-111S2) for regulatory environmental compliance. Details may be found at: [www.national.com/quality/green](http://www.national.com/quality/green).

Lead free products are RoHS compliant.



**National Semiconductor**  
**Americas Customer**  
**Support Center**  
 Email: [new.feedback@nsc.com](mailto:new.feedback@nsc.com)  
 Tel: 1-800-272-9959

**National Semiconductor**  
**Europe Customer Support Center**  
 Fax: +49 (0) 180-530 85 86  
 Email: [europe.support@nsc.com](mailto:europe.support@nsc.com)  
 Deutsch Tel: +49 (0) 69 9508 6208  
 English Tel: +44 (0) 870 24 0 2171  
 Français Tel: +33 (0) 1 41 91 8790

**National Semiconductor**  
**Asia Pacific Customer**  
**Support Center**  
 Email: [ap.support@nsc.com](mailto:ap.support@nsc.com)

**National Semiconductor**  
**Japan Customer Support Center**  
 Fax: 81-3-5639-7507  
 Email: [jpn.feedback@nsc.com](mailto:jpn.feedback@nsc.com)

# LMC555 CMOS Timer