

LM79LXXAC Series 3-Terminal Negative Regulators

 Check for Samples: [LM79L05](#), [LM79L05AC](#), [LM79L12](#), [LM79L12AC](#), [LM79L15](#), [LM79L15AC](#)

FEATURES

- **Preset Output Voltage Error is Less than $\pm 5\%$ Over Load, Line and Temperature**
- **Specified at an Output Current of 100mA**
- **Easily Compensated with a Small $0.1\mu\text{F}$ Output Capacitor**
- **Internal Short-Circuit, Thermal and Safe Operating Area Protection**
- **Easily Adjustable to Higher Output Voltages**
- **Maximum Line Regulation Less than $0.07\% V_{\text{OUT}}/V$**
- **Maximum Load Regulation Less than $0.01\% V_{\text{OUT}}/mA$**
- **See AN-1112 (SNVA009) for DSBGA Considerations**

DESCRIPTION

The LM79LXXAC series of 3-terminal negative voltage regulators features fixed output voltages of $-5V$, $-12V$, and $-15V$ with output current capabilities in excess of 100mA. These devices were designed using the latest computer techniques for optimizing the packaged IC thermal/electrical performance. The LM79LXXAC series, when combined with a minimum output capacitor of $0.1\mu\text{F}$, exhibits an excellent transient response, a maximum line regulation of $0.07\% V_{\text{O}}/V$, and a maximum load regulation of $0.01\% V_{\text{O}}/mA$.

The LM79LXXAC series also includes, as self-protection circuitry: safe operating area circuitry for output transistor power dissipation limiting, a temperature independent short circuit current limit for peak output current limiting, and a thermal shutdown circuit to prevent excessive junction temperature. Although designed primarily as fixed voltage regulators, these devices may be combined with simple external circuitry for boosted and/or adjustable voltages and currents. The LM79LXXAC series is available in the 3-lead TO package, the 8-lead SOIC package, and the 6-Bump DSBGA package.

For output voltages other than the pre-set $-5V$, $-12V$ and $-15V$, the LM137L series provides an adjustable output voltage range from $-1.2V$ to $-47V$.

Typical Applications

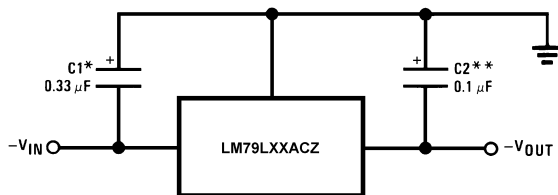

- *Required if the regulator is located far from the power supply filter. A $1\mu\text{F}$ aluminum electrolytic may be substituted.
- **Required for stability. A $1\mu\text{F}$ aluminum electrolytic may be substituted.

Figure 1. Fixed Output Regulator

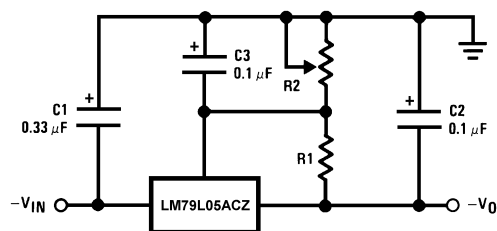

$$-V_0 = -5V - (5V/R1 + I_Q) \cdot R2,$$

$$5V/R1 > 3 I_Q$$

Figure 2. Adjustable Output Regulator



Please be aware that an important notice concerning availability, standard warranty, and use in critical applications of Texas Instruments semiconductor products and disclaimers thereto appears at the end of this data sheet.

All trademarks are the property of their respective owners.

Connection Diagram

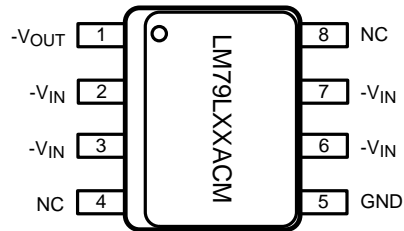

Pins labeled 'NC' on LM79LXXACM 8-Lead SOIC (pin 4 and pin 8) are Open, no internal connection.

**Figure 3. 8-Lead SOIC Narrow (D)
Top View**

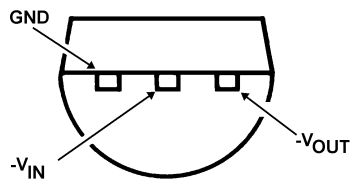

**Figure 4. 3-Lead TO-226 (LP)
Bottom View**

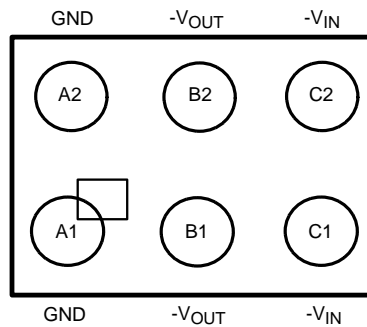

**Figure 5. 6-Bump DSBGA
Top View (Bump Side Down)**



These devices have limited built-in ESD protection. The leads should be shorted together or the device placed in conductive foam during storage or handling to prevent electrostatic damage to the MOS gates.

Absolute Maximum Ratings⁽¹⁾⁽²⁾

Input Voltage	
$V_O = -5V, -12V, -15V$	-35V
Internal Power Dissipation ⁽³⁾	Internally Limited
Operating Temperature Range	0°C to +70°C
Maximum Junction Temperature	+125°C
Storage Temperature Range	-55°C to +150°C
Lead Temperature	
(Soldering, 10 sec.)	260°C

- (1) Absolute Maximum Ratings indicate limits beyond which damage to the device may occur. Operating Ratings indicate conditions for which the device is functional.
- (2) If Military/Aerospace specified devices are required, please contact the Texas Instruments Sales Office/Distributors for availability and specifications.
- (3) Thermal resistance of TO-226 (LP) package is 60°C/W θ_{JC} , 232°C/W θ_{JA} at still air, and 88°C/W at 400 ft/min of air. The θ_{JA} of the LM78LXX in the 6-Bump DSBGA package is 114°C/W when mounted on a 4-Layer JEDEC test board (JESD 51-7). The θ_{JA} of the LM78LXX in the SOIC-8 (D) package is 180°C/W in still air. The maximum junction temperature shall not exceed 125°C on electrical parameters.

Electrical Characteristics⁽¹⁾
 $T_A = 0^\circ\text{C to } +70^\circ\text{C}$ unless otherwise noted.

Output Voltage			-5V			-12V			-15V			
Input Voltage (unless otherwise noted)			-10V			-17V			-20V			
Symbol	Parameter	Conditions	Min	Typ	Max	Min	Typ	Max	Min	Typ	Max	Units
V_O	Output Voltage	$T_J = 25^\circ\text{C}, I_O = 100\text{mA}$	-5.2	-5	-4.8	-12.5	-12	-11.5	-15.6	-15	-14.4	V
		$1\text{mA} \leq I_O \leq 100\text{mA}$	-5.25		-4.75	-12.6		-11.4	-15.7		-14.25	
		$V_{MIN} \leq V_{IN} \leq V_{MAX}$	(-20 \leq $V_{IN} \leq$ -7.5)			(-27 \leq $V_{IN} \leq$ -14.8)			(-30 \leq $V_{IN} \leq$ -18)			
		$1\text{mA} \leq I_O \leq 40\text{mA}$	-5.25		-4.75	-12.6		-11.4	-15.7		-14.25	
		$V_{MIN} \leq V_{IN} \leq V_{MAX}$	(-20 \leq $V_{IN} \leq$ -7)			(-27 \leq $V_{IN} \leq$ -14.5)			(-30 \leq $V_{IN} \leq$ -17.5)			
ΔV_O	Line Regulation	$T_J = 25^\circ\text{C}, I_O = 100\text{mA}$			60			45			45	mV
		$V_{MIN} \leq V_{IN} \leq V_{MAX}$	(-20 \leq $V_{IN} \leq$ -7.3)			(-27 \leq $V_{IN} \leq$ -14.6)			(-30 \leq $V_{IN} \leq$ -17.7)			
		$T_J = 25^\circ\text{C}, I_O = 40\text{mA}$			60			45			45	mV
		$V_{MIN} \leq V_{IN} \leq V_{MAX}$	(-20 \leq $V_{IN} \leq$ -7)			(-27 \leq $V_{IN} \leq$ -14.5)			(-30 \leq $V_{IN} \leq$ -17.5)			
ΔV_O	Load Regulation	$T_J = 25^\circ\text{C}$			50			100			125	mV
		$1\text{mA} \leq I_O \leq 100\text{mA}$										
ΔV_O	Long Term Stability	$I_O = 100\text{mA}$		20			48			60		mV/khrs
I_Q	Quiescent Current	$I_O = 100\text{mA}$		2	6		2	6		2	6	mA
ΔI_Q	Quiescent Current Change	$1\text{mA} \leq I_O \leq 100\text{mA}$			0.3			0.3			0.3	mA
		$1\text{mA} \leq I_O \leq 40\text{mA}$			0.1			0.1			0.1	
		$I_O = 100\text{mA}$			0.25			0.25			0.25	mA
		$V_{MIN} \leq V_{IN} \leq V_{MAX}$	(-20 \leq $V_{IN} \leq$ -7.5)			(-27 \leq $V_{IN} \leq$ -14.8)			(-30 \leq $V_{IN} \leq$ -18)			
V_n	Output Noise Voltage	$T_J = 25^\circ\text{C}, I_O = 100\text{mA}$ $f = 10\text{Hz} - 10\text{kHz}$		40			96			120		μV
$\Delta V_{IN}/\Delta V_O$	Ripple Rejection	$T_J = 25^\circ\text{C}, I_O = 100\text{mA}$ $f = 120\text{Hz}$	50			52			50			dB
	Input Voltage Required to Maintain Line Regulation	$T_J = 25^\circ\text{C}, I_O = 100\text{mA}$			-7.3			-14.6			-17.7	V
		$I_O = 40\text{mA}$			-7.0			-14.5			-17.5	V

- (1) To ensure constant junction temperature, low duty cycle pulse testing is used.

Typical Performance Characteristics

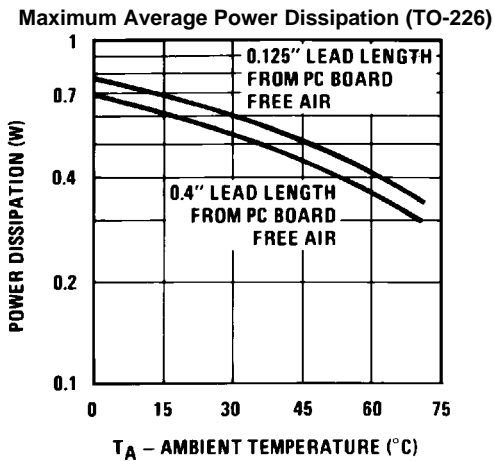

Figure 6.

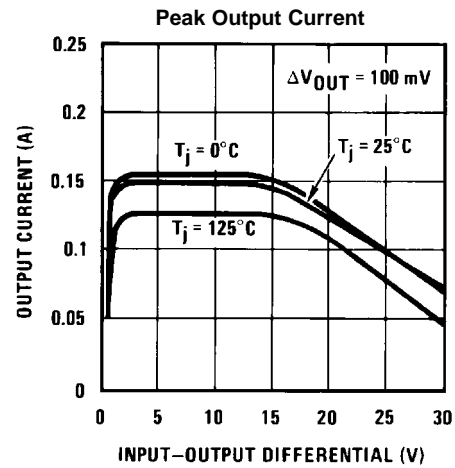

Figure 7.

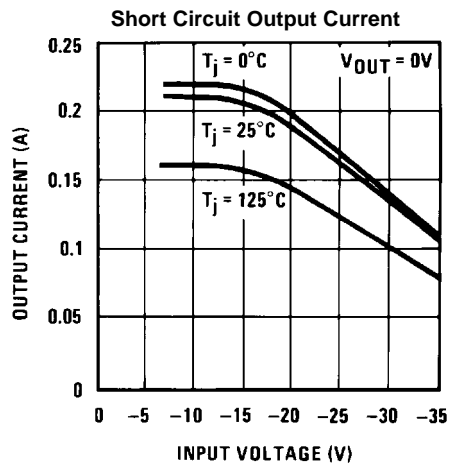

Figure 8.

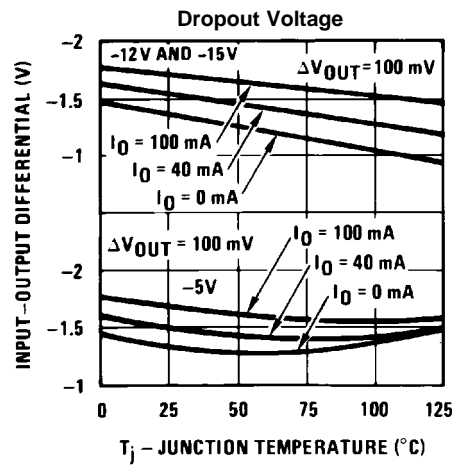

Figure 9.

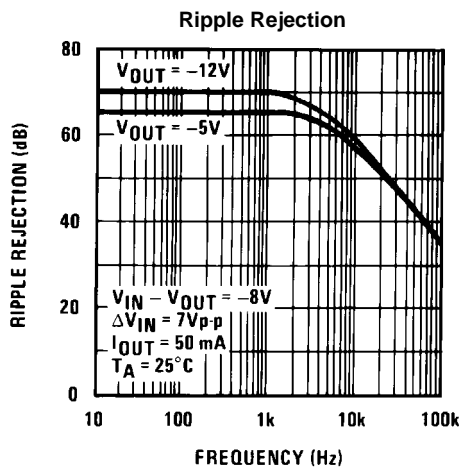

Figure 10.

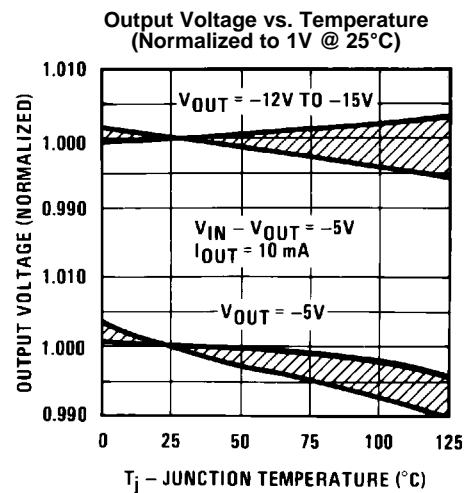
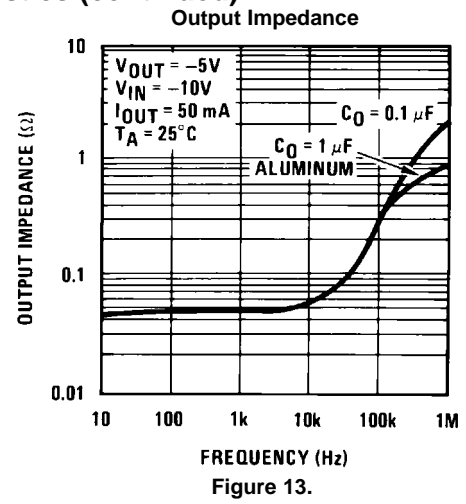
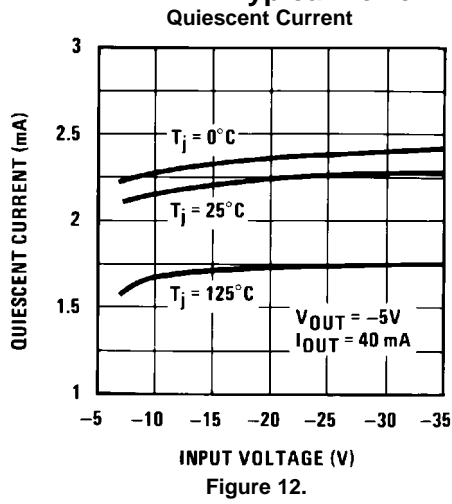

Figure 11.

Typical Performance Characteristics (continued)



TYPICAL APPLICATIONS

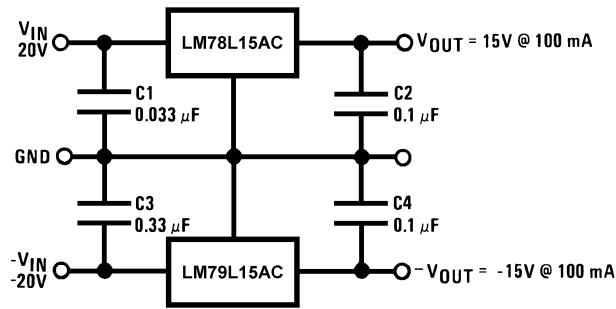

Figure 14. ±15V, 100mA Dual Power Supply

Schematic Diagrams

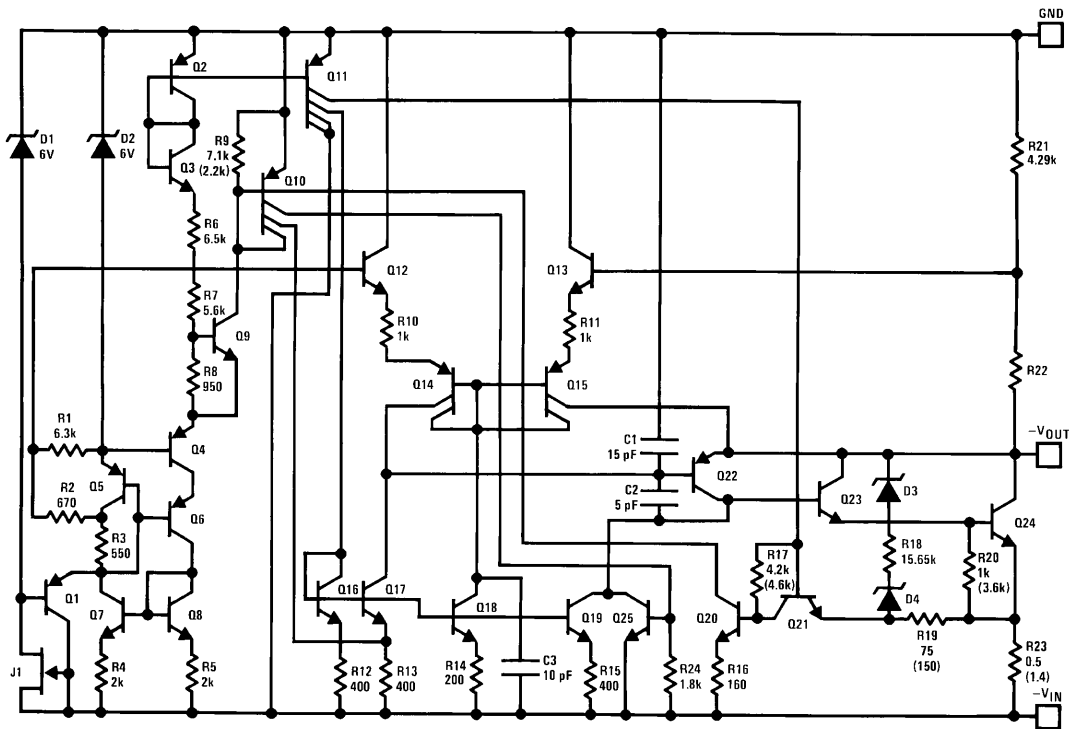

Figure 15. -5V Schematic Diagram

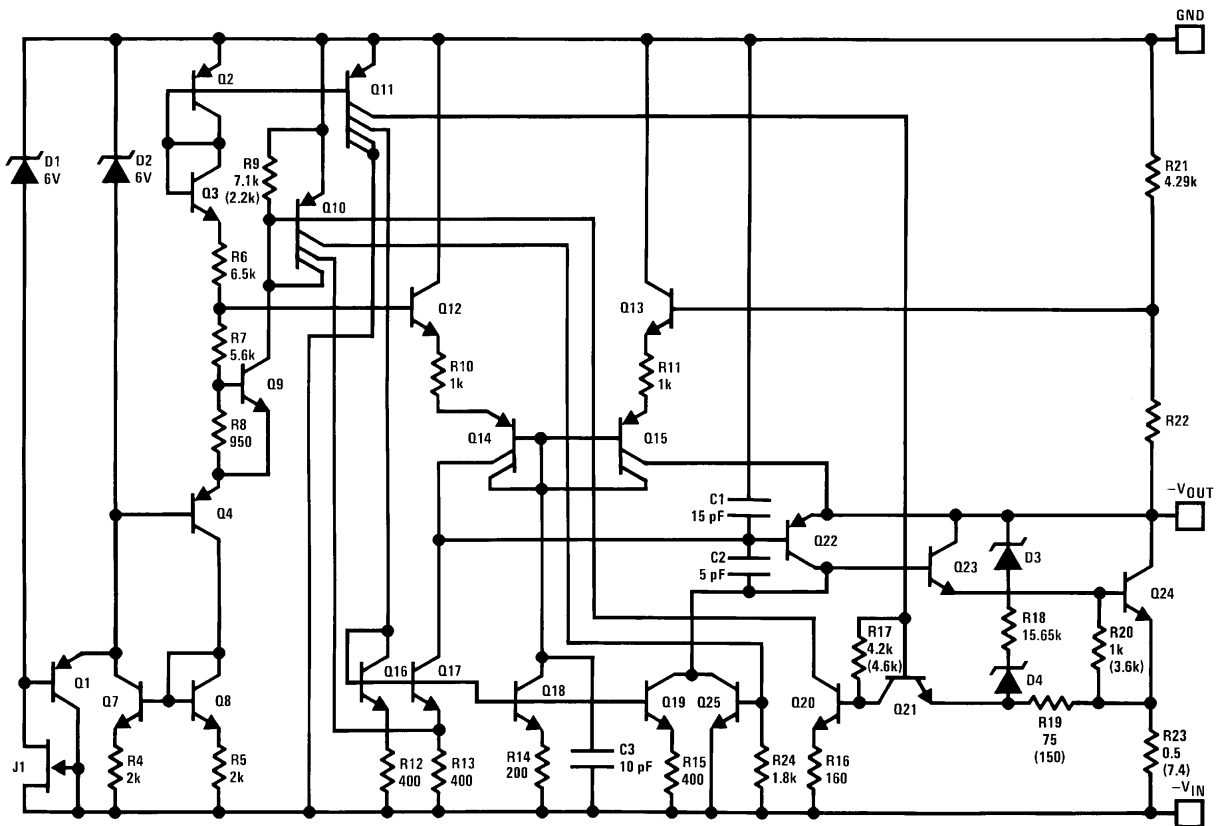

Figure 16. -12V and -15V Schematic Diagram

REVISION HISTORY

Changes from Revision J (April 2013) to Revision K	Page
• Changed layout of National Data Sheet to TI format	7

PACKAGING INFORMATION

Orderable Device	Status (1)	Package Type	Package Drawing	Pins	Package Qty	Eco Plan (2)	Lead/Ball Finish	MSL Peak Temp (3)	Op Temp (°C)	Top-Side Markings (4)	Samples
1.004.022	ACTIVE	SOIC	D	8	2500	TBD	Call TI	Call TI	0 to 70	LM79L05ACM	Samples
LM79L05ACM	ACTIVE	SOIC	D	8	95	TBD	Call TI	Call TI	0 to 70	LM79L05ACM	Samples
LM79L05ACM/NOPB	ACTIVE	SOIC	D	8	95	Green (RoHS & no Sb/Br)	CU SN	Level-1-260C-UNLIM	0 to 70	LM79L05ACM	Samples
LM79L05ACMX	ACTIVE	SOIC	D	8	2500	TBD	Call TI	Call TI	0 to 70	LM79L05ACM	Samples
LM79L05ACMX/NOPB	ACTIVE	SOIC	D	8	2500	Green (RoHS & no Sb/Br)	CU SN	Level-1-260C-UNLIM	0 to 70	LM79L05ACM	Samples
LM79L05ACTL/NOPB	ACTIVE	DSBGA	YZR	6	250	Green (RoHS & no Sb/Br)	SNAGCU	Level-1-260C-UNLIM	0 to 70	P B	Samples
LM79L05ACTLX/NOPB	ACTIVE	DSBGA	YZR	6	3000	Green (RoHS & no Sb/Br)	SNAGCU	Level-1-260C-UNLIM	0 to 70	P B	Samples
LM79L05ACZ/LFT1	ACTIVE	TO-92	LP	3	2000	Green (RoHS & no Sb/Br)	SNCU	Level-1-NA-UNLIM		320L 79L05	Samples
LM79L05ACZ/NOPB	ACTIVE	TO-92	LP	3	1800	Green (RoHS & no Sb/Br)	SNCU	Level-1-NA-UNLIM	0 to 70	320L 79L05	Samples
LM79L12ACM	ACTIVE	SOIC	D	8	95	TBD	Call TI	Call TI	0 to 70	LM79L12ACM	Samples
LM79L12ACM/NOPB	ACTIVE	SOIC	D	8	95	Green (RoHS & no Sb/Br)	CU SN	Level-1-260C-UNLIM	0 to 70	LM79L12ACM	Samples
LM79L12ACMX	ACTIVE	SOIC	D	8	2500	TBD	Call TI	Call TI	0 to 70	LM79L12ACM	Samples
LM79L12ACMX/NOPB	ACTIVE	SOIC	D	8	2500	Green (RoHS & no Sb/Br)	CU SN	Level-1-260C-UNLIM	0 to 70	LM79L12ACM	Samples
LM79L12ACZ/LFT4	ACTIVE	TO-92	LP	3	2000	Green (RoHS & no Sb/Br)	SNCU	Level-1-NA-UNLIM		320L 79L12	Samples
LM79L12ACZ/LFT7	ACTIVE	TO-92	LP	3	2000	Green (RoHS & no Sb/Br)	SNCU	Level-1-NA-UNLIM		320L 79L12	Samples
LM79L12ACZ/NOPB	ACTIVE	TO-92	LP	3	1800	Green (RoHS & no Sb/Br)	SNCU	Level-1-NA-UNLIM	0 to 70	320L 79L12	Samples
LM79L15ACM	ACTIVE	SOIC	D	8	95	TBD	Call TI	Call TI	0 to 70	LM79L15ACM	Samples

Orderable Device	Status (1)	Package Type	Package Drawing	Pins	Package Qty	Eco Plan (2)	Lead/Ball Finish	MSL Peak Temp (3)	Op Temp (°C)	Top-Side Markings (4)	Samples
LM79L15ACM/NOPB	ACTIVE	SOIC	D	8	95	Green (RoHS & no Sb/Br)	CU SN	Level-1-260C-UNLIM	0 to 70	LM79L 15ACM	Samples
LM79L15ACMX	ACTIVE	SOIC	D	8	2500	TBD	Call TI	Call TI	0 to 70	LM79L 15ACM	Samples
LM79L15ACMX/NOPB	ACTIVE	SOIC	D	8	2500	Green (RoHS & no Sb/Br)	CU SN	Level-1-260C-UNLIM	0 to 70	LM79L 15ACM	Samples

(1) The marketing status values are defined as follows:

ACTIVE: Product device recommended for new designs.

LIFEBUY: TI has announced that the device will be discontinued, and a lifetime-buy period is in effect.

NRND: Not recommended for new designs. Device is in production to support existing customers, but TI does not recommend using this part in a new design.

PREVIEW: Device has been announced but is not in production. Samples may or may not be available.

OBSOLETE: TI has discontinued the production of the device.

(2) Eco Plan - The planned eco-friendly classification: Pb-Free (RoHS), Pb-Free (RoHS Exempt), or Green (RoHS & no Sb/Br) - please check <http://www.ti.com/productcontent> for the latest availability information and additional product content details.

TBD: The Pb-Free/Green conversion plan has not been defined.

Pb-Free (RoHS): TI's terms "Lead-Free" or "Pb-Free" mean semiconductor products that are compatible with the current RoHS requirements for all 6 substances, including the requirement that lead not exceed 0.1% by weight in homogeneous materials. Where designed to be soldered at high temperatures, TI Pb-Free products are suitable for use in specified lead-free processes.

Pb-Free (RoHS Exempt): This component has a RoHS exemption for either 1) lead-based flip-chip solder bumps used between the die and package, or 2) lead-based die adhesive used between the die and leadframe. The component is otherwise considered Pb-Free (RoHS compatible) as defined above.

Green (RoHS & no Sb/Br): TI defines "Green" to mean Pb-Free (RoHS compatible), and free of Bromine (Br) and Antimony (Sb) based flame retardants (Br or Sb do not exceed 0.1% by weight in homogeneous material)

(3) MSL, Peak Temp. -- The Moisture Sensitivity Level rating according to the JEDEC industry standard classifications, and peak solder temperature.

(4) Multiple Top-Side Markings will be inside parentheses. Only one Top-Side Marking contained in parentheses and separated by a "~" will appear on a device. If a line is indented then it is a continuation of the previous line and the two combined represent the entire Top-Side Marking for that device.

Important Information and Disclaimer: The information provided on this page represents TI's knowledge and belief as of the date that it is provided. TI bases its knowledge and belief on information provided by third parties, and makes no representation or warranty as to the accuracy of such information. Efforts are underway to better integrate information from third parties. TI has taken and continues to take reasonable steps to provide representative and accurate information but may not have conducted destructive testing or chemical analysis on incoming materials and chemicals. TI and TI suppliers consider certain information to be proprietary, and thus CAS numbers and other limited information may not be available for release.

In no event shall TI's liability arising out of such information exceed the total purchase price of the TI part(s) at issue in this document sold by TI to Customer on an annual basis.

D (R-PDSO-G8)

PLASTIC SMALL OUTLINE

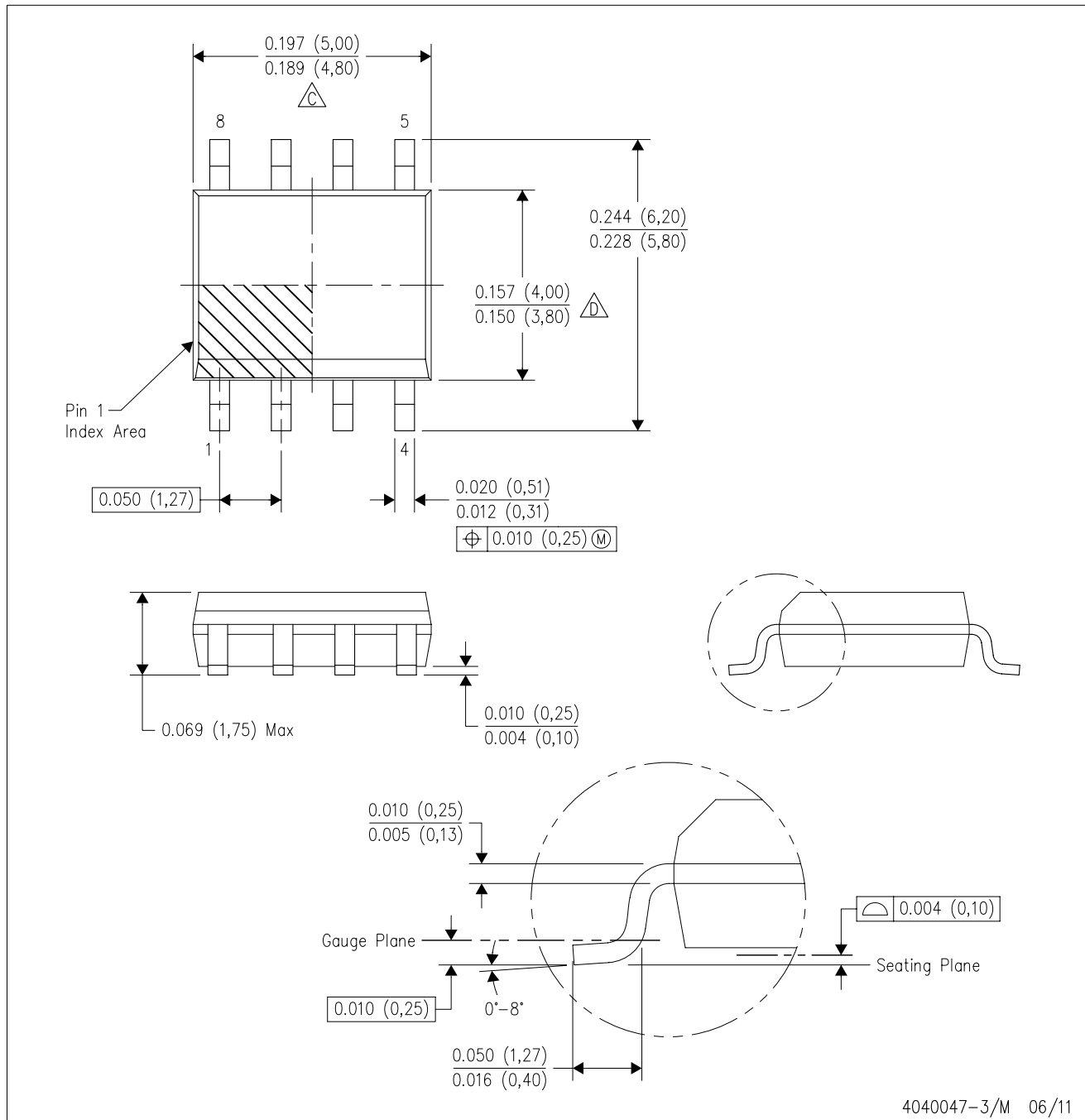

LP (O-PBCY-W3)

PLASTIC CYLINDRICAL PACKAGE

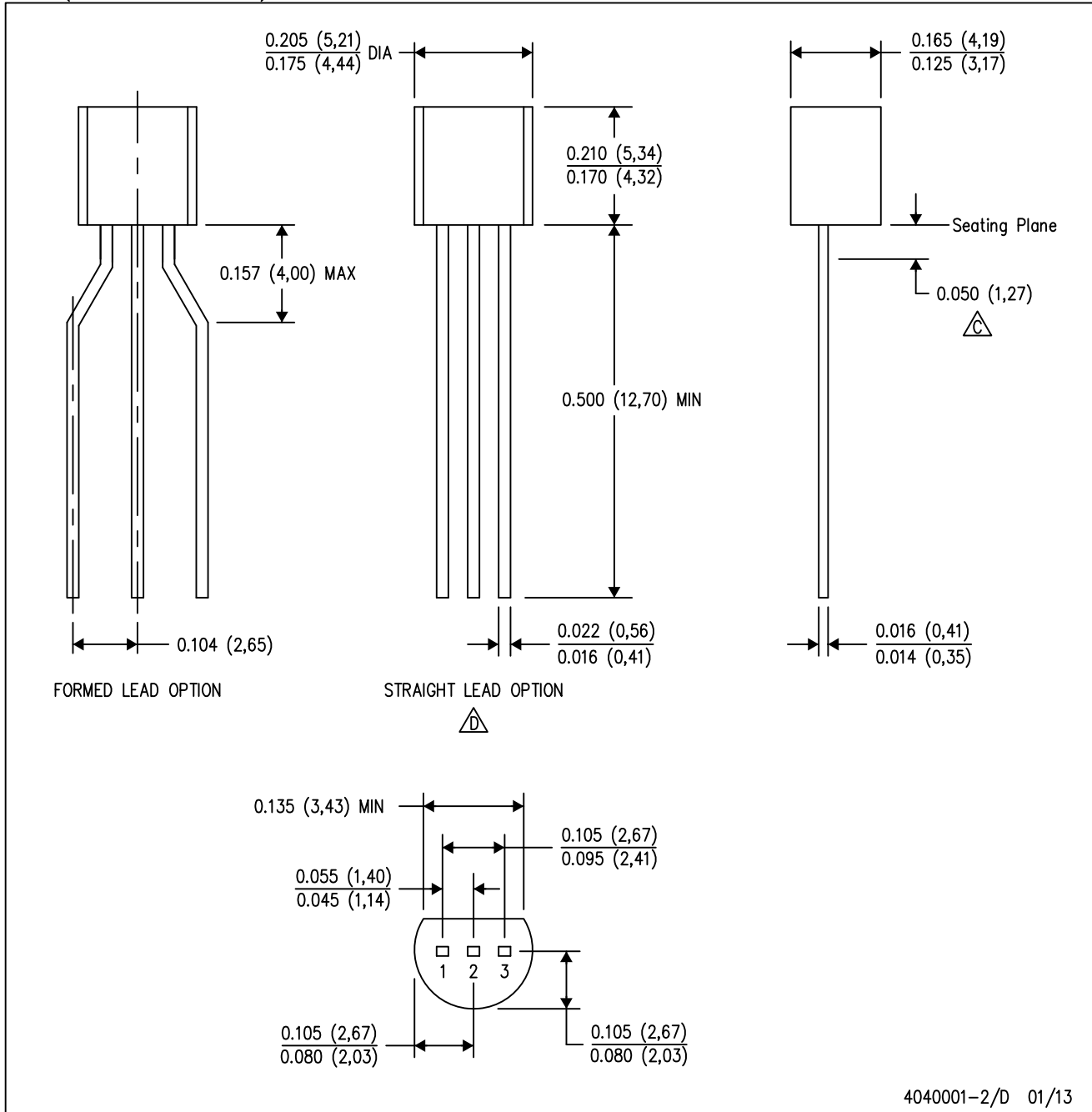

- NOTES:
- A. All linear dimensions are in inches (millimeters).
 - B. This drawing is subject to change without notice.
 - C. Lead dimensions are not controlled within this area.
 - D. Falls within JEDEC TO-226 Variation AA (TO-226 replaces TO-92).
 - E. Shipping Method:
 - Straight lead option available in either bulk pack or tape & reel.
 - Formed lead option available in tape & reel or ammo pack.
 - Specific products can be offered in limited combinations of shipping mediums and lead options.
 - Consult product folder for more information on available options.

MECHANICAL DATA

LP (O-PBCY-W3)

PLASTIC CYLINDRICAL PACKAGE

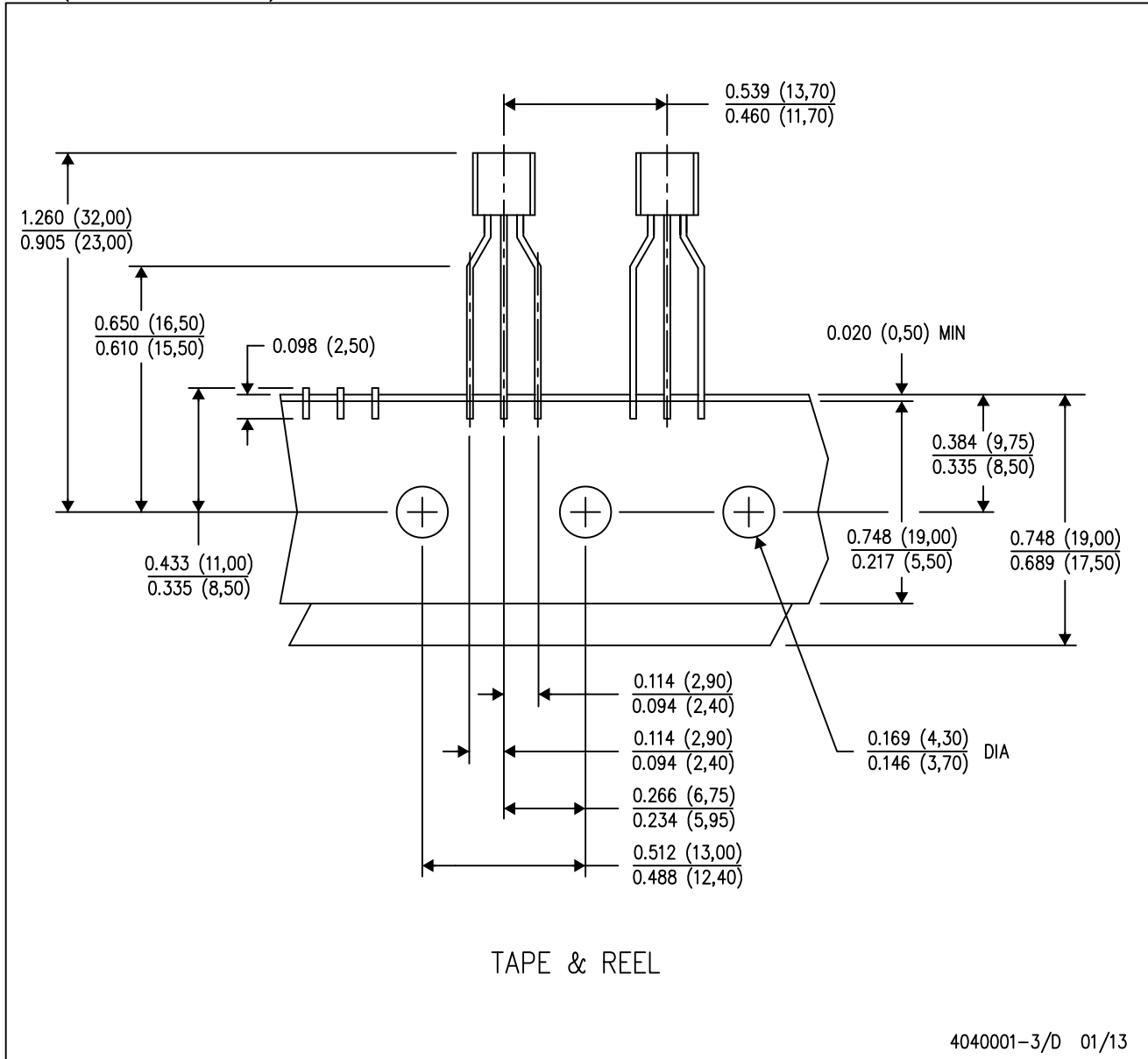

- NOTES:
- All linear dimensions are in inches (millimeters).
 - This drawing is subject to change without notice.
 - Tape and Reel information for the Formed Lead Option package.

IMPORTANT NOTICE

Texas Instruments Incorporated and its subsidiaries (TI) reserve the right to make corrections, enhancements, improvements and other changes to its semiconductor products and services per JESD46, latest issue, and to discontinue any product or service per JESD48, latest issue. Buyers should obtain the latest relevant information before placing orders and should verify that such information is current and complete. All semiconductor products (also referred to herein as "components") are sold subject to TI's terms and conditions of sale supplied at the time of order acknowledgment.

TI warrants performance of its components to the specifications applicable at the time of sale, in accordance with the warranty in TI's terms and conditions of sale of semiconductor products. Testing and other quality control techniques are used to the extent TI deems necessary to support this warranty. Except where mandated by applicable law, testing of all parameters of each component is not necessarily performed.

TI assumes no liability for applications assistance or the design of Buyers' products. Buyers are responsible for their products and applications using TI components. To minimize the risks associated with Buyers' products and applications, Buyers should provide adequate design and operating safeguards.

TI does not warrant or represent that any license, either express or implied, is granted under any patent right, copyright, mask work right, or other intellectual property right relating to any combination, machine, or process in which TI components or services are used. Information published by TI regarding third-party products or services does not constitute a license to use such products or services or a warranty or endorsement thereof. Use of such information may require a license from a third party under the patents or other intellectual property of the third party, or a license from TI under the patents or other intellectual property of TI.

Reproduction of significant portions of TI information in TI data books or data sheets is permissible only if reproduction is without alteration and is accompanied by all associated warranties, conditions, limitations, and notices. TI is not responsible or liable for such altered documentation. Information of third parties may be subject to additional restrictions.

Resale of TI components or services with statements different from or beyond the parameters stated by TI for that component or service voids all express and any implied warranties for the associated TI component or service and is an unfair and deceptive business practice. TI is not responsible or liable for any such statements.

Buyer acknowledges and agrees that it is solely responsible for compliance with all legal, regulatory and safety-related requirements concerning its products, and any use of TI components in its applications, notwithstanding any applications-related information or support that may be provided by TI. Buyer represents and agrees that it has all the necessary expertise to create and implement safeguards which anticipate dangerous consequences of failures, monitor failures and their consequences, lessen the likelihood of failures that might cause harm and take appropriate remedial actions. Buyer will fully indemnify TI and its representatives against any damages arising out of the use of any TI components in safety-critical applications.

In some cases, TI components may be promoted specifically to facilitate safety-related applications. With such components, TI's goal is to help enable customers to design and create their own end-product solutions that meet applicable functional safety standards and requirements. Nonetheless, such components are subject to these terms.

No TI components are authorized for use in FDA Class III (or similar life-critical medical equipment) unless authorized officers of the parties have executed a special agreement specifically governing such use.

Only those TI components which TI has specifically designated as military grade or "enhanced plastic" are designed and intended for use in military/aerospace applications or environments. Buyer acknowledges and agrees that any military or aerospace use of TI components which have **not** been so designated is solely at the Buyer's risk, and that Buyer is solely responsible for compliance with all legal and regulatory requirements in connection with such use.

TI has specifically designated certain components as meeting ISO/TS16949 requirements, mainly for automotive use. In any case of use of non-designated products, TI will not be responsible for any failure to meet ISO/TS16949.

Products

Audio	www.ti.com/audio
Amplifiers	amplifier.ti.com
Data Converters	dataconverter.ti.com
DLP® Products	www.dlp.com
DSP	dsp.ti.com
Clocks and Timers	www.ti.com/clocks
Interface	interface.ti.com
Logic	logic.ti.com
Power Mgmt	power.ti.com
Microcontrollers	microcontroller.ti.com
RFID	www.ti-rfid.com
OMAP Applications Processors	www.ti.com/omap
Wireless Connectivity	www.ti.com/wirelessconnectivity

Applications

Automotive and Transportation	www.ti.com/automotive
Communications and Telecom	www.ti.com/communications
Computers and Peripherals	www.ti.com/computers
Consumer Electronics	www.ti.com/consumer-apps
Energy and Lighting	www.ti.com/energy
Industrial	www.ti.com/industrial
Medical	www.ti.com/medical
Security	www.ti.com/security
Space, Avionics and Defense	www.ti.com/space-avionics-defense
Video and Imaging	www.ti.com/video

TI E2E Community

e2e.ti.com