

Three-terminal adjustable negative voltage regulators

Features

- Output voltage adjustable down to V_{REF}
- 1.5 A guaranteed output current
- 0.3%/V typical load regulation
- 0.01%/V typical line regulation
- Current limit constant with temperature
- Ripple rejection: 77 dB
- Standard 3-lead transistor packages
- Excellent thermal regulation: 0.002%/V
- 50 ppm/°C temperature coefficient

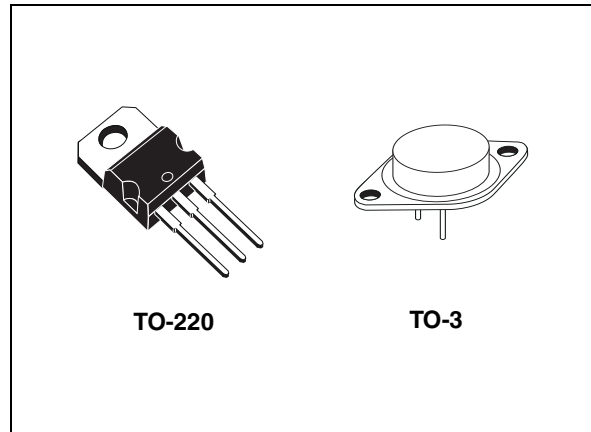

Description

The LM137 series are adjustable 3-terminal negative voltage regulators capable of supplying in excess -1.5 A over a -1.2 to -37 V output voltage range. They are exceptionally easy to use and require only two external resistors to set the output voltage. Further, both line and load regulation are better than standard fixed regulators. Also, LM137 regulators are supplied in standard transistor packages which are easily mounted and handled. In addition to higher performance than fixed regulators, the LM137 series offer full overload protection available only in integrated circuits. Included on the chip are current limit, thermal overload protection and safe area protection. All overload protection circuitry remains fully functional even if the adjustment terminal is disconnected.

Table 1. Device summary

Part numbers	Order codes	Packages	Temperature range
LM137	LM137K	TO-3	- 55 °C to 150 °C
LM337	LM337K	TO-3	0 °C to 125 °C
LM337	LM337SP	TO-220	0 °C to 125 °C

Contents

1	Diagram	3
2	Pin configuration	4
3	Maximum ratings	5
4	Electrical characteristics	6
5	Typical characteristics	8
6	Thermal regulation	10
7	Typical application	11
8	Package mechanical data	14
9	Revision history	17

1 Diagram

Figure 1. Schematic diagram

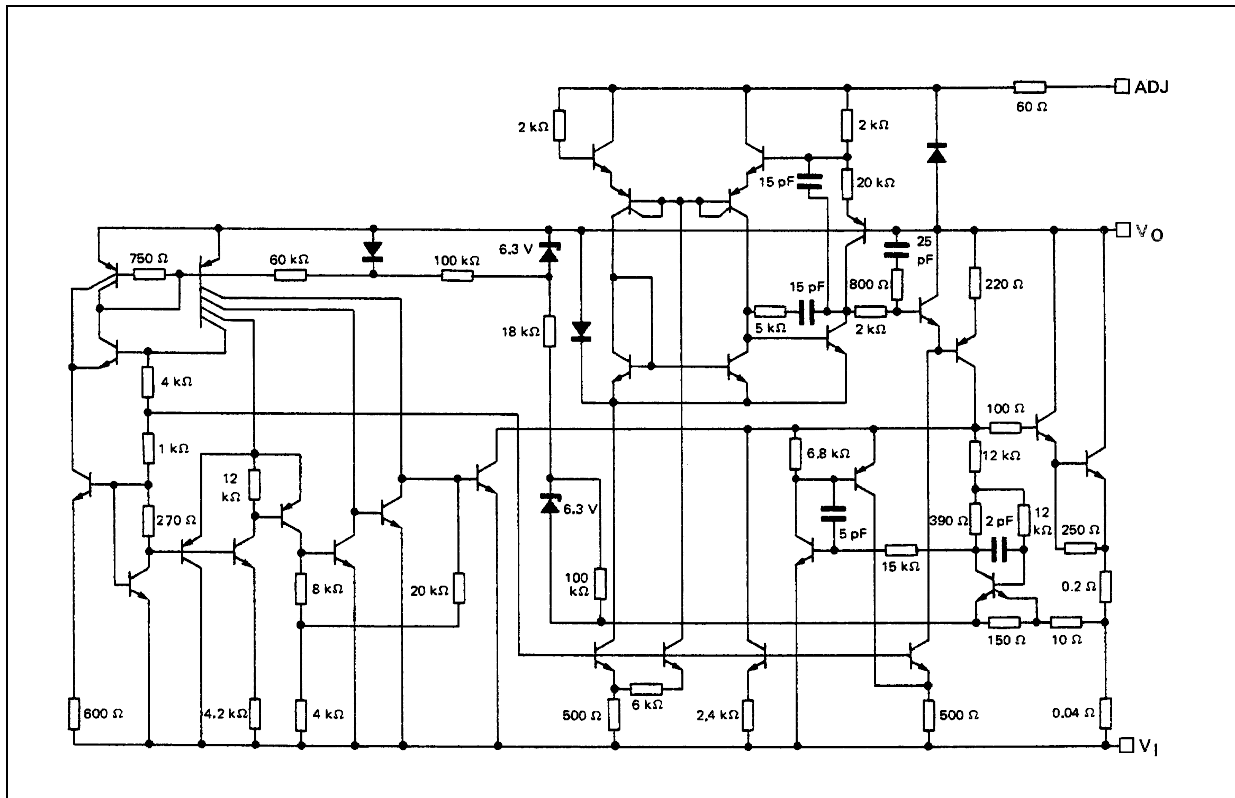

2 Pin configuration

Figure 2. Pin connections (top view)

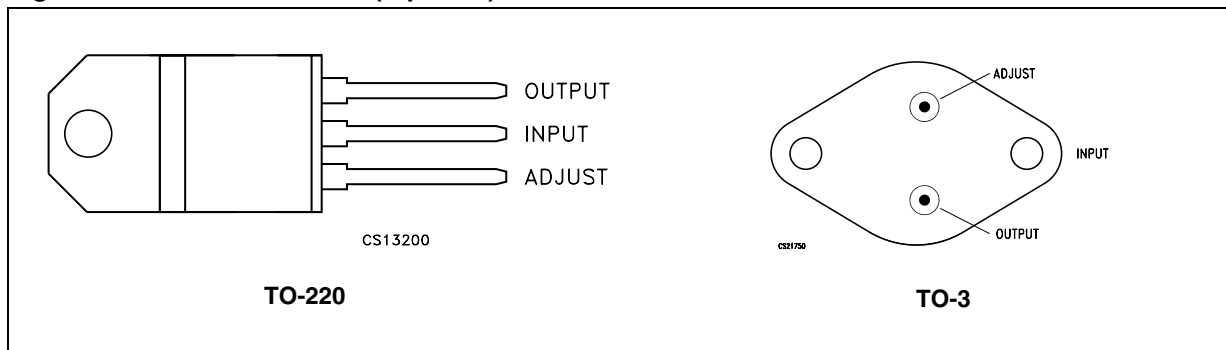

3 Maximum ratings

Table 2. Absolute maximum ratings

Symbol	Parameter	Value	Unit
$V_I - V_O$	Input output voltage differential	40	V
I_O	Output current	1.5	A
P_D	Power dissipation	Internally limited	
T_{STG}	Storage temperature range	- 65 to 150	°C
T_{OP}	Operating junction temperature range	LM137	- 55 to 150
		LM337	0 to 125

Note: Absolute maximum ratings are those values beyond which damage to the device may occur. Functional operation under these condition is not implied.

Table 3. Thermal data

Symbol	Parameter	TO-220	TO-3	Unit
R_{thJC}	Thermal resistance junction-case max.	3	4	°C/W
R_{thJA}	Thermal resistance junction-ambient max.	70	35	°C/W

4 Electrical characteristics

$T_J = -55$ to 150 °C, $V_I - V_O = 5$ V, $I_O = 0.5$ A unless otherwise specified.

Table 4. Electrical characteristics of LM137

Symbol	Parameter	Test conditions	Min.	Typ.	Max.	Unit	
V_{REF}	Reference voltage	$T_a = 25^\circ\text{C}$	-1.225	-1.25	-1.275	V	
		$ V_I - V_O = 3$ to 40 V, $T_J = T_{min}$ to T_{max} $ I_O = 10\text{mA}$ to $ I_{O(max)} $, $P \leq P_{max}$	-1.2	-1.25	-1.3		
K_{VI}	Line regulation ⁽¹⁾	$T_a = 25^\circ\text{C}$ $ V_I - V_O = 3$ to 40 V	$I_O = 0.1$ A		0.01	0.02	%V
			$I_O = 20$ mA		0.01	0.02	
K_{VO}	Load regulation ⁽¹⁾	$T_a = 25^\circ\text{C}$ $ I_O = 10\text{mA}$ to $ I_{O(max)} $	$ V_O \leq 5$ V		15	25	mV
			$ V_O \geq 5$ V		0.3	0.5	%
	Thermal regulation	$T_a = 25^\circ\text{C}$, pulse 10 ms		0.002	0.02	%/W	
I_{ADJ}	Adjustment pin current			65	100	μA	
ΔI_{ADJ}	Adjustment pin current change	$T_a = 25^\circ\text{C}$, $ I_O = 10$ mA to $ I_{O(max)} $ $ V_I - V_O = 3$ to 40 V		2	5	μA	
K_{VI}	Line regulation ⁽¹⁾	$ V_I - V_O = 3$ to 40 V		0.02	0.05	%V	
K_{VO}	Load regulation ⁽¹⁾	$ I_O = 10\text{mA}$ to $ I_{O(max)} $	$ V_O \leq 5$ V		20	50	mV
			$ V_O \geq 5$ V		0.3	1	%
$ I_{O(min)} $	Minimum load current	$ V_I - V_O \leq 40$ V		2.5	5	mA	
		$ V_I - V_O \leq 10$ V		1.2	3		
I_{OS}	Short circuit output current	$ V_I - V_O \leq 15$ V	1.5	2.2		A	
		$ V_I - V_O = 40$ V, $T_J = 25^\circ\text{C}$	0.24	0.4			
V_{NO}	RMS output noise (% of V_O)	$T_a = 25^\circ\text{C}$, $f = 10$ Hz to 10 kHz		0.003		%	
R_{VF}	Ripple rejection ratio	$V_O = -10$ V, $f = 120$ Hz		60		dB	
		$C_{ADJ} = 10$ μF	66	77			
K_{VT}	Temperature stability			0.6		%	
K_{VH}	Long term stability	$T_a = 125^\circ\text{C}$, 1000 H		0.3	1	%	

1. Regulation is measured at constant junction temperature, using pulse testing with a low duty cycle. Changes in output voltage due to heating effects are covered under the specification for thermal regulation.

$T_J = 0$ to 150 °C unless otherwise specified.

Table 5. Electrical characteristics of LM337

Symbol	Parameter	Test conditions	Min.	Typ.	Max.	Unit	
V _{REF}	Reference voltage	T _a = 25°C	-1.213	-1.25	-1.287	V	
		V _I - V _O = 3 to 40 V, T _J = T _{min} to T _{max} I _O = 10mA to I _{O(max)} , P ≤ P _{max}	-1.2	-1.25	-1.3		
K _{VI}	Line regulation ⁽¹⁾	T _a = 25°C V _I - V _O = 3 to 40 V	I _O = 0.1 A		0.01	0.04	%V
			I _O = 20 mA		0.01	0.04	
K _{VO}	Load regulation ⁽¹⁾	T _a = 25°C I _O = 10mA to I _{O(max)}	V _O ≤ 5 V		15	50	mV
			V _O ≥ 5 V		0.3	1	%
	Thermal regulation	T _a = 25°C, pulse 10 ms		0.003	0.04	%/W	
I _{ADJ}	Adjustment pin current			65	100	μA	
ΔI _{ADJ}	Adjustment pin current change	T _a = 25°C, I _O = 10 mA to I _{O(max)} V _I - V _O = 3 to 40 V		2	5	μA	
K _{VI}	Line regulation ⁽¹⁾	V _I - V _O = 3 to 40 V		0.02	0.07	%V	
K _{VO}	Load regulation ⁽¹⁾	I _O = 10mA to I _{O(max)}	V _O ≤ 5 V		20	70	mV
			V _O ≥ 5 V		0.3	1.5	%
I _{O(min)}	Minimum load current	V _I - V _O ≤ 40 V		2.5	10	mA	
		V _I - V _O ≤ 10 V		1.5	6		
I _{OS}	Short circuit output current	V _I - V _O ≤ 15 V	1.5	2.2		A	
		V _I - V _O = 40 V, T _J = 25°C	0.15	0.4			
V _{NO}	RMS output noise (% of V _O)	T _a = 25°C, f = 10 Hz to 10 kHz		0.003		%	
R _{VF}	Ripple rejection ratio	V _O = -10 V, f = 120 Hz		60		dB	
		C _{ADJ} = 10 μF	66	77			
K _{VT}	Temperature stability			0.6		%	
K _{VH}	Long term stability	T _a = 125°C, 1000 H		0.3	1	%	

1. Regulation is measured at constant junction temperature, using pulse testing with a low duty cycle. Changes in output voltage due to heating effects are covered under the specification for thermal regulation.

5 Typical characteristics

Figure 3. Load regulation

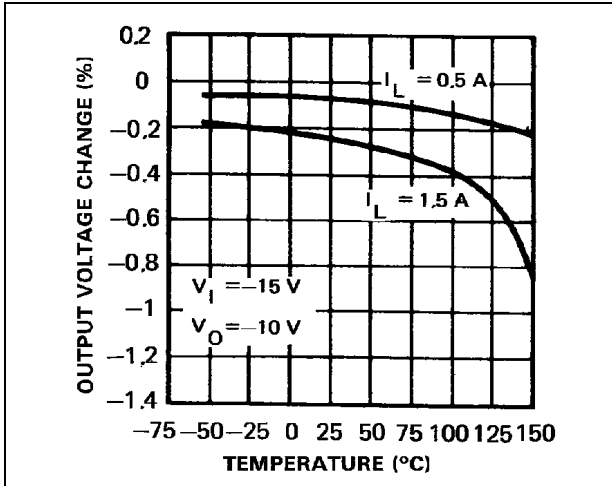

Figure 4. Current limit

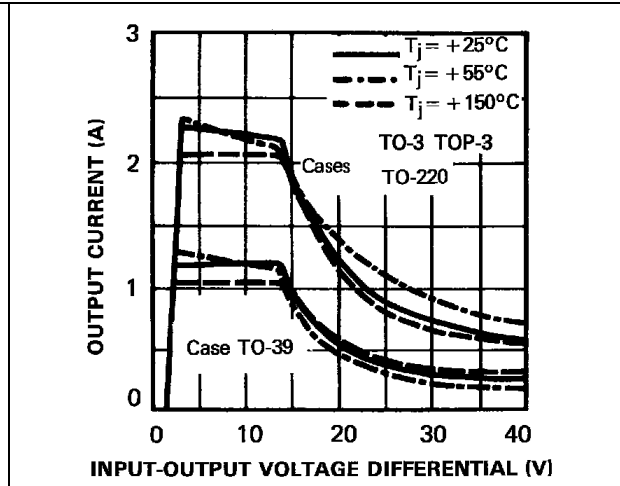

Figure 5. Adjustment current

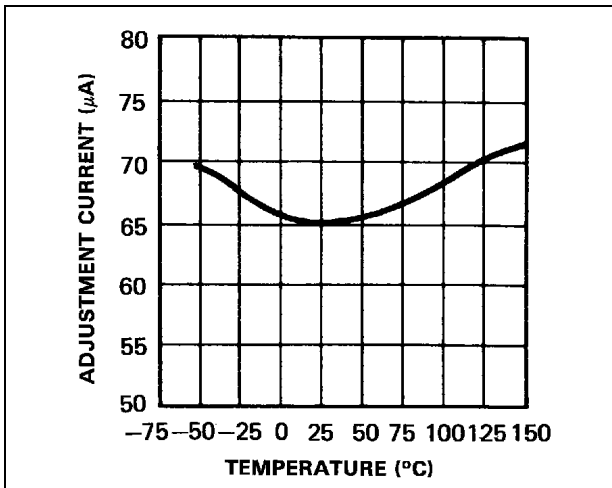

Figure 6. Dropout voltage

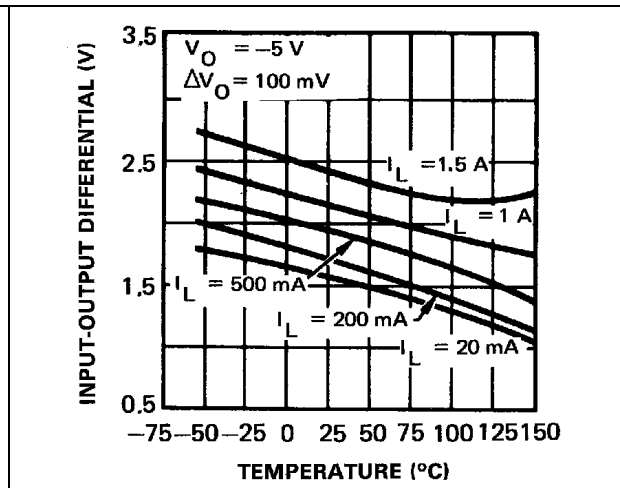

Figure 7. Temperature stability

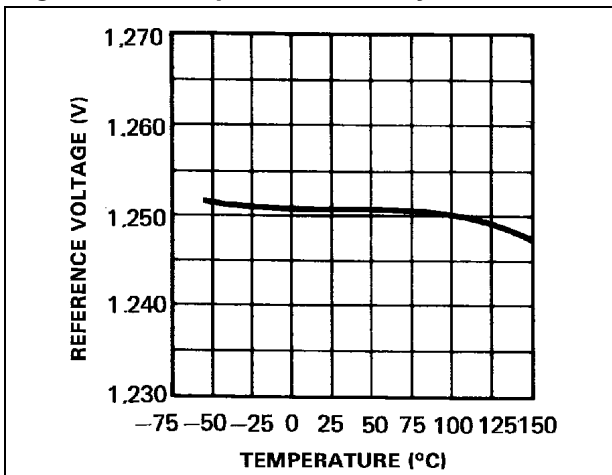

Figure 8. Minimum operating current

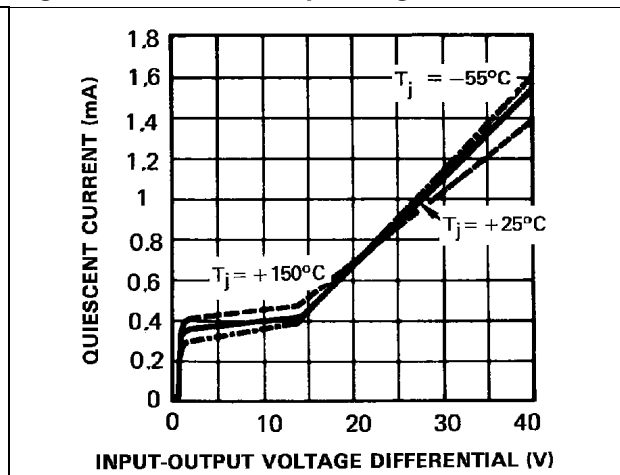

Figure 9. Ripple rejection vs. output voltage

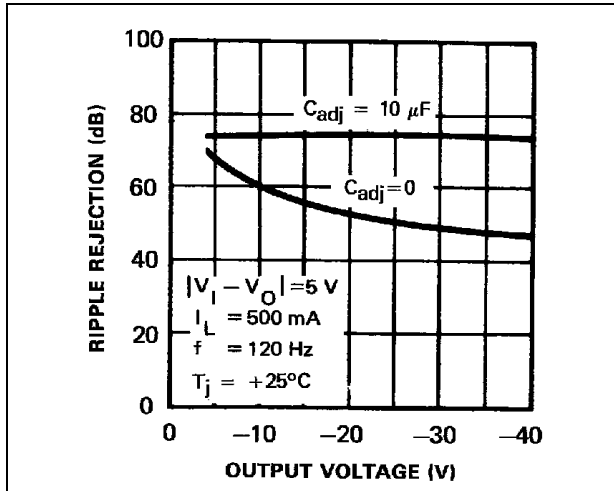

Figure 10. Ripple rejection vs. frequency

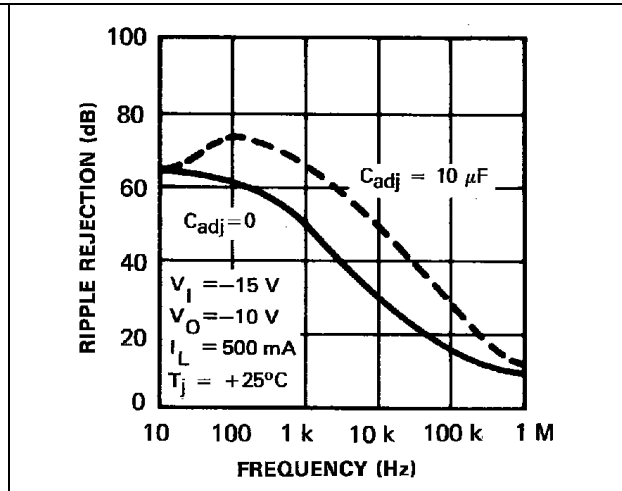

Figure 11. Ripple rejection vs. output current

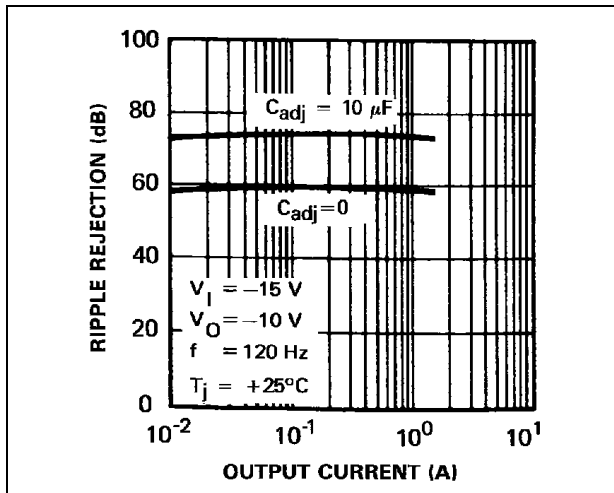

Figure 12. Output impedance

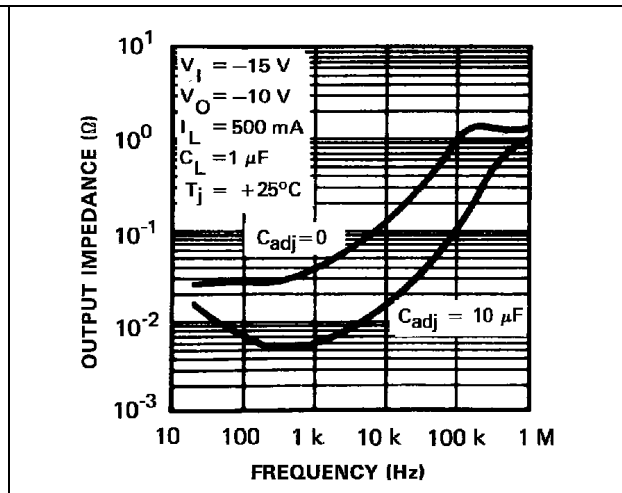

Figure 13. Line transient response

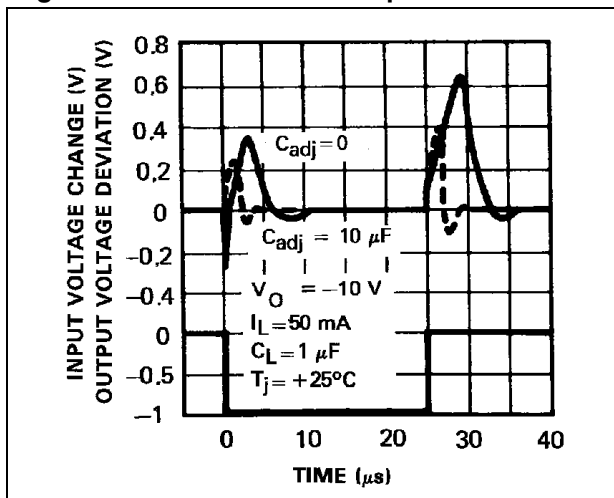
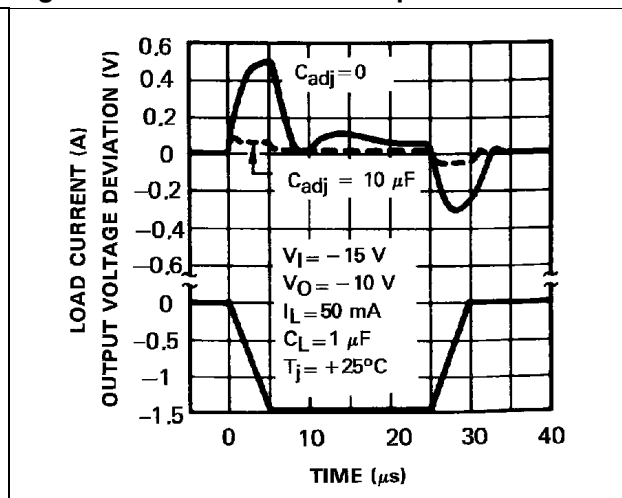

Figure 14. Load transient response



6 Thermal regulation

When power is dissipated in an IC, a temperature gradient occurs across the IC chip affecting the individual IC circuit components. With an IC regulator, this gradient can be especially severe since power dissipation is large.

Thermal regulation is the effect of these temperature gradients on output voltage (in percentage output change) per watt of power change in a specified time. Thermal regulation error is independent of electrical regulation or temperature coefficient, and occurs within 5 ms to 50 ms after a change in power dissipation. Thermal regulation depends on IC layout as well as electrical design. The thermal regulation of a voltage regulator is defined as the percentage change of V_O , per watt, within the first 10ms after a step of power, is applied.

The LM137 specification is 0.02%/W max. In [Figure 1](#), a typical LM337's output drifts only 3 mV for 0.03% of $V_O = -10$ V) when a 10 W pulse is applied for 10 ms. This performance is thus well inside the specification limit of 0.02%/W x 10 W = 0.2% max. When the 10 W pulse is ended the thermal regulation again shows a 3 mV step as the LM137 chip cools off. Note that the load regulation error of about 8 mV (0.08%) is additional to the thermal regulation error.

In [Figure 2](#), when the 10 W pulse is applied for 100 ms, the output drifts only slightly beyond the drift in the first 10 ms and the thermal error stays well within 0.1% (10 mV).

7 Typical application

Figure 15. Adjustable negative voltage regulator

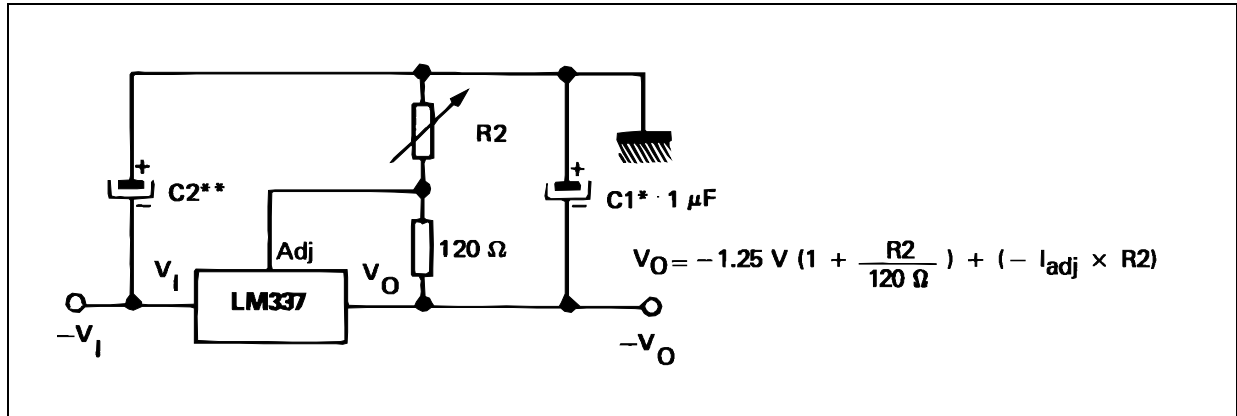

* C1 = 1 μF solid tantalum or 10 μF aluminium electrolytic required for stability.

** C2 = 1 μF solid tantalum is required only if regulator is more than 10 cm from power supply filter capacitors

Figure 16. Adjustable lab voltage regulator

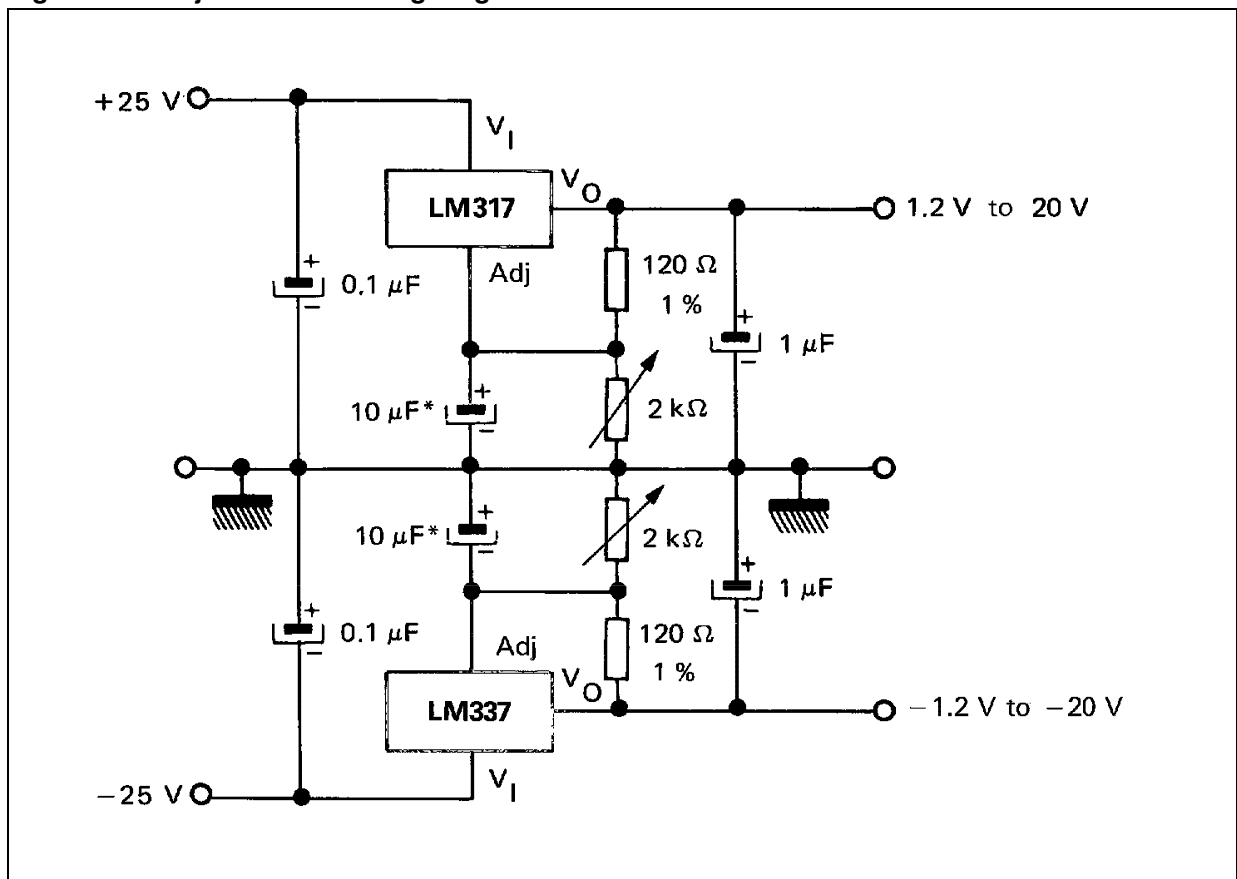

* The 10 μF capacitors are optimal to improve ripple rejection.

Figure 17. Current regulator

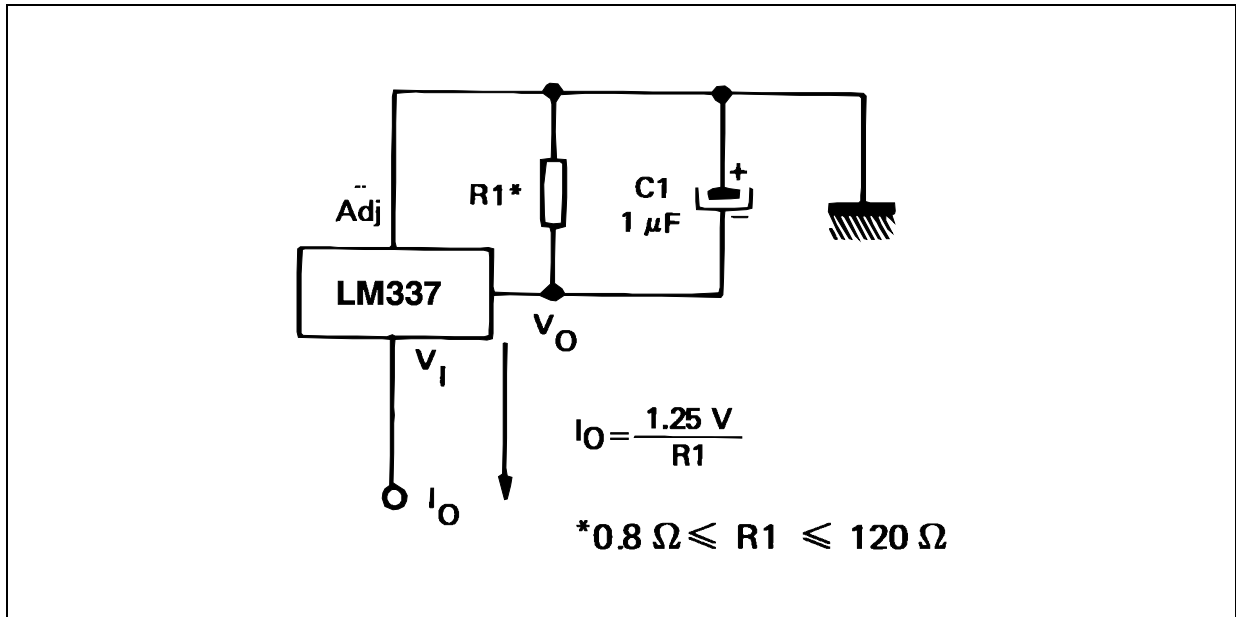
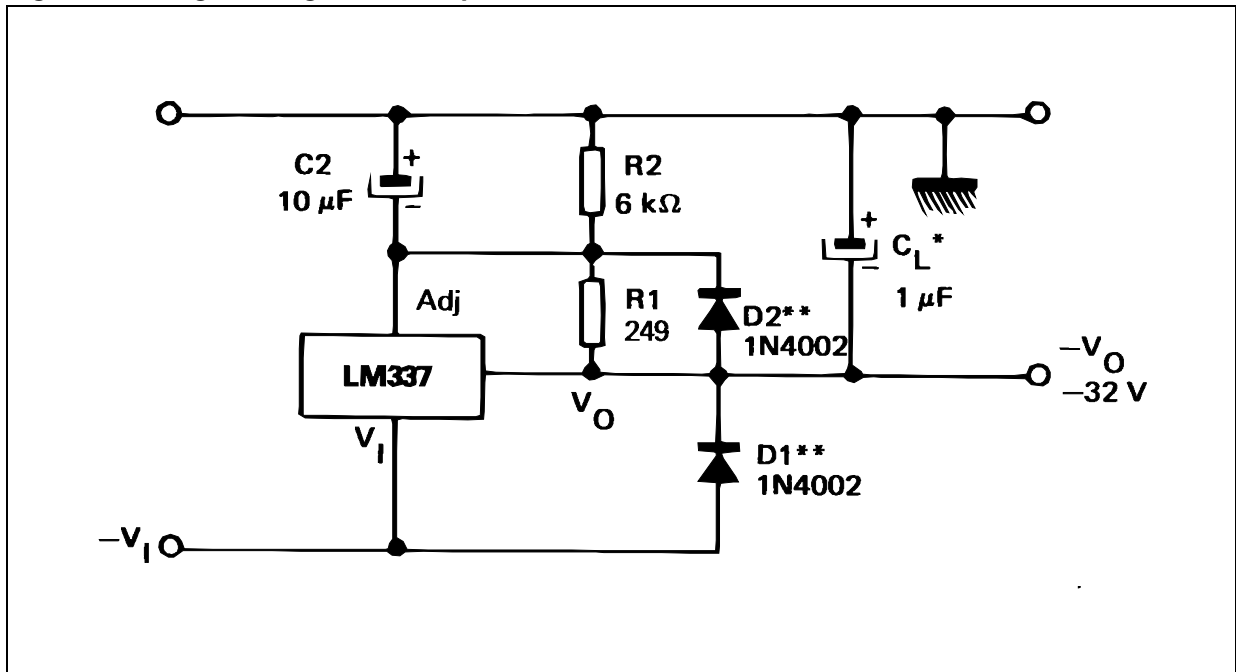

Figure 18. Negative regulator with protection diodes



* When C_L is larger than $20 \mu\text{F}$, D1 protects the LM137 in case the input supply is shorted.

** When $C2$ is larger than $10 \mu\text{F}$ and V_O is larger than -25 V , D2 protects the LM137 in case the output is shorted.

Figure 19. - 5.2 V regulator with electronic shutdown (1)

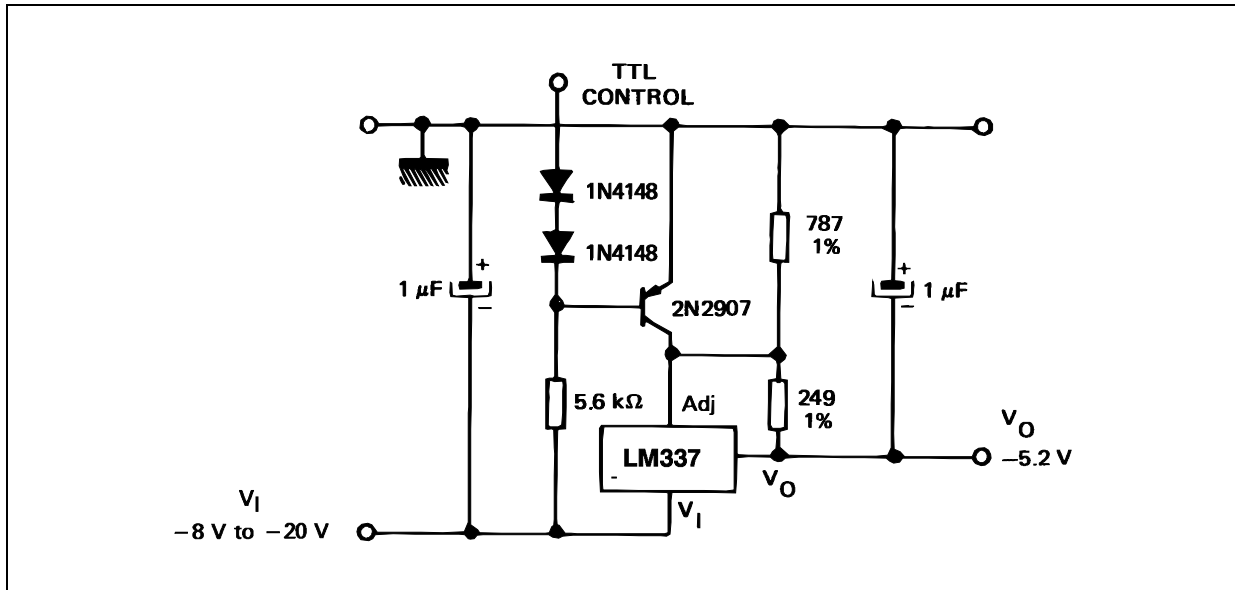

1. Minimum output = - 1.3 V when control input is low.

Figure 20. Current regulator

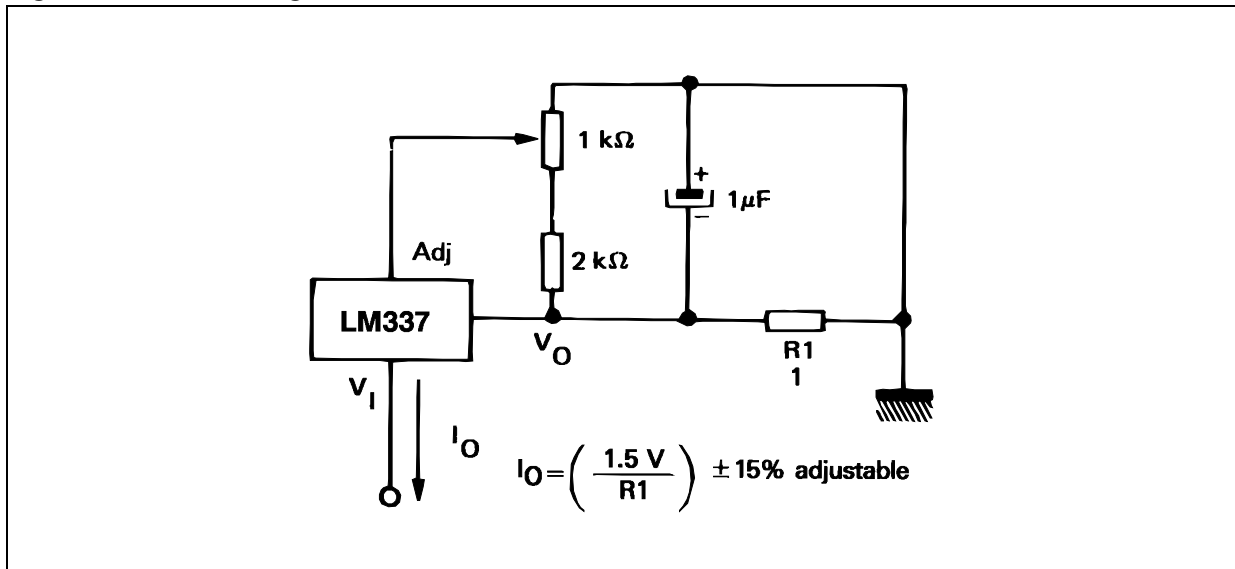

8 Package mechanical data

In order to meet environmental requirements, ST offers these devices in different grades of ECOPACK[®] packages, depending on their level of environmental compliance. ECOPACK[®] specifications, grade definitions and product status are available at: www.st.com. ECOPACK[®] is an ST trademark.

TO-220 mechanical data

Dim.	mm.			inch.		
	Min.	Typ.	Max.	Min.	Typ.	Max.
A	4.40		4.60	0.173		0.181
C	1.23		1.32	0.048		0.051
D	2.40		2.72	0.094		0.107
D1		1.27			0.050	
E	0.49		0.70	0.019		0.027
F	0.61		0.88	0.024		0.034
F1	1.14		1.70	0.044		0.067
F2	1.14		1.70	0.044		0.067
G	4.95		5.15	0.194		0.203
G1	2.4		2.7	0.094		0.106
H2	10.0		10.40	0.393		0.409
L2		16.4			0.645	
L4	13.0		14.0	0.511		0.551
L5	2.65		2.95	0.104		0.116
L6	15.25		15.75	0.600		0.620
L7	6.2		6.6	0.244		0.260
L9	3.5		3.93	0.137		0.154
DIA.	3.75		3.85	0.147		0.151

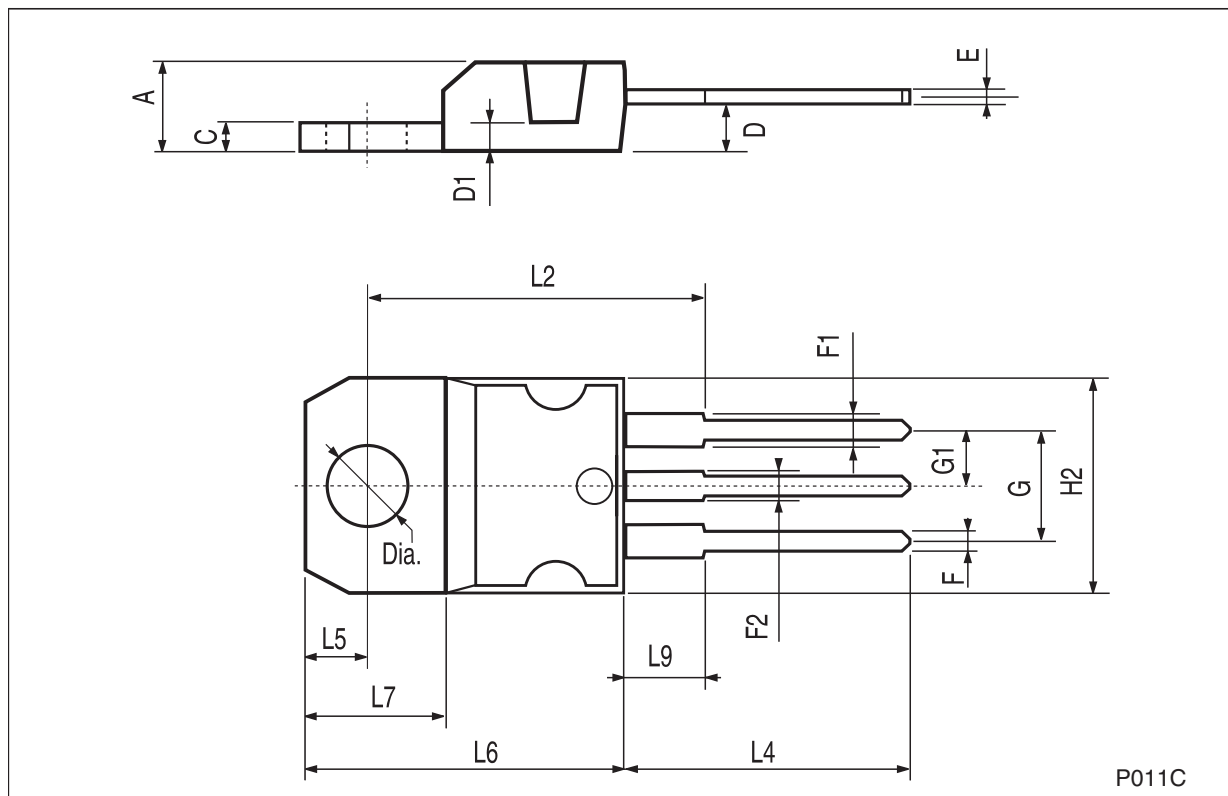

TO-3 mechanical data

Dim.	mm.			inch.		
	Min.	Typ.	Max.	Min.	Typ.	Max.
A		11.85			0.466	
B	0.96	1.05	1.10	0.037	0.041	0.043
C			1.70			0.066
D			8.7			0.342
E			20.0			0.787
G		10.9			0.429	
N		16.9			0.665	
P			26.2			1.031
R	3.88		4.09	0.152		0.161
U			39.5			1.555
V		30.10			1.185	

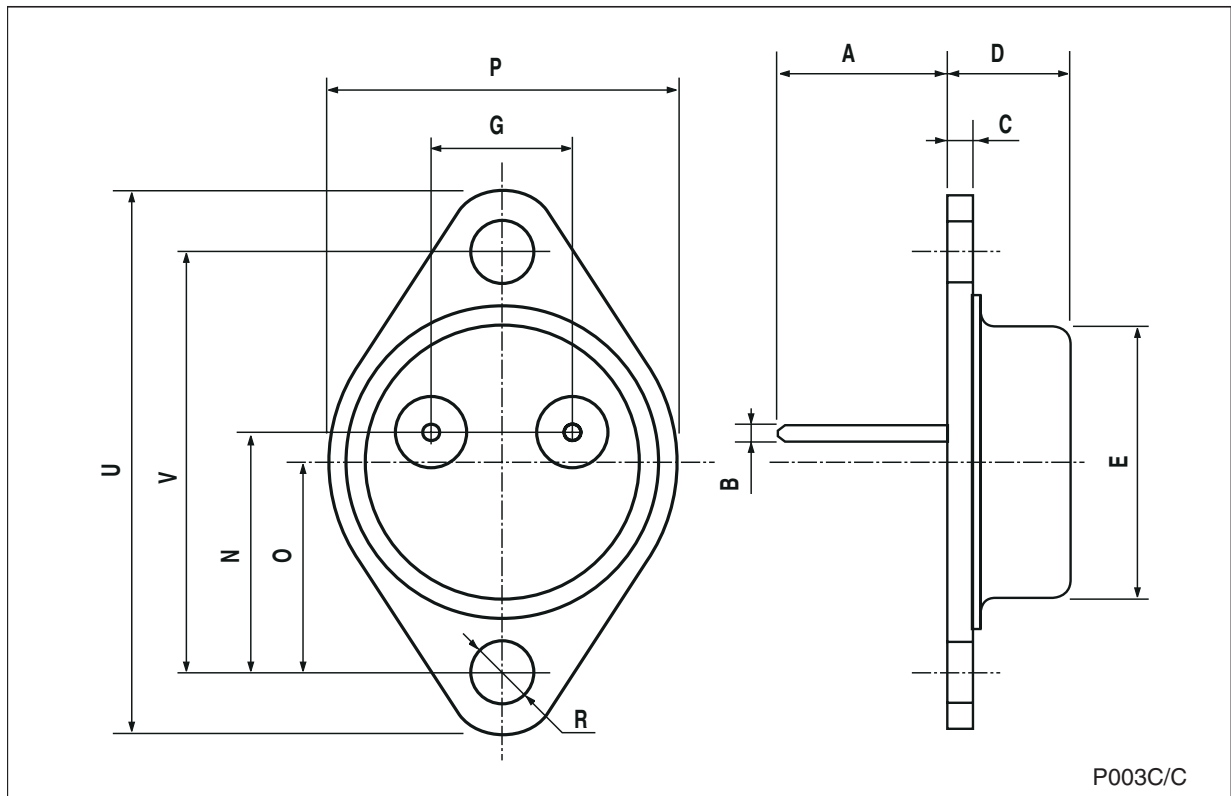

P003C/C

9 Revision history

Table 6. Document revision history

Date	Revision	Changes
19-Jul-2004	1	First issue.
10-Jan-2005	2	Modified pin connection for TO-3.
17-Jul-2008	3	Added: Table 1 on page 1 .
03-Oct-2011	4	Modified: Table 1 on page 1 .

Please Read Carefully:

Information in this document is provided solely in connection with ST products. STMicroelectronics NV and its subsidiaries ("ST") reserve the right to make changes, corrections, modifications or improvements, to this document, and the products and services described herein at any time, without notice.

All ST products are sold pursuant to ST's terms and conditions of sale.

Purchasers are solely responsible for the choice, selection and use of the ST products and services described herein, and ST assumes no liability whatsoever relating to the choice, selection or use of the ST products and services described herein.

No license, express or implied, by estoppel or otherwise, to any intellectual property rights is granted under this document. If any part of this document refers to any third party products or services it shall not be deemed a license grant by ST for the use of such third party products or services, or any intellectual property contained therein or considered as a warranty covering the use in any manner whatsoever of such third party products or services or any intellectual property contained therein.

UNLESS OTHERWISE SET FORTH IN ST'S TERMS AND CONDITIONS OF SALE ST DISCLAIMS ANY EXPRESS OR IMPLIED WARRANTY WITH RESPECT TO THE USE AND/OR SALE OF ST PRODUCTS INCLUDING WITHOUT LIMITATION IMPLIED WARRANTIES OF MERCHANTABILITY, FITNESS FOR A PARTICULAR PURPOSE (AND THEIR EQUIVALENTS UNDER THE LAWS OF ANY JURISDICTION), OR INFRINGEMENT OF ANY PATENT, COPYRIGHT OR OTHER INTELLECTUAL PROPERTY RIGHT.

UNLESS EXPRESSLY APPROVED IN WRITING BY TWO AUTHORIZED ST REPRESENTATIVES, ST PRODUCTS ARE NOT RECOMMENDED, AUTHORIZED OR WARRANTED FOR USE IN MILITARY, AIR CRAFT, SPACE, LIFE SAVING, OR LIFE SUSTAINING APPLICATIONS, NOR IN PRODUCTS OR SYSTEMS WHERE FAILURE OR MALFUNCTION MAY RESULT IN PERSONAL INJURY, DEATH, OR SEVERE PROPERTY OR ENVIRONMENTAL DAMAGE. ST PRODUCTS WHICH ARE NOT SPECIFIED AS "AUTOMOTIVE GRADE" MAY ONLY BE USED IN AUTOMOTIVE APPLICATIONS AT USER'S OWN RISK.

Resale of ST products with provisions different from the statements and/or technical features set forth in this document shall immediately void any warranty granted by ST for the ST product or service described herein and shall not create or extend in any manner whatsoever, any liability of ST.

ST and the ST logo are trademarks or registered trademarks of ST in various countries.

Information in this document supersedes and replaces all information previously supplied.

The ST logo is a registered trademark of STMicroelectronics. All other names are the property of their respective owners.

© 2011 STMicroelectronics - All rights reserved

STMicroelectronics group of companies

Australia - Belgium - Brazil - Canada - China - Czech Republic - Finland - France - Germany - Hong Kong - India - Israel - Italy - Japan - Malaysia - Malta - Morocco - Philippines - Singapore - Spain - Sweden - Switzerland - United Kingdom - United States of America

www.st.com