

## LM231A/LM231/LM331A/LM331 Precision Voltage-to-Frequency Converters

Check for Samples: [LM231](#), [LM331](#)

### FEATURES

- Ensured Linearity 0.01% max
- Improved Performance in Existing Voltage-to-Frequency Conversion Applications
- Split or Single Supply Operation
- Operates on Single 5V Supply
- Pulse Output Compatible with All Logic Forms
- Excellent Temperature Stability:  $\pm 50$  ppm/ $^{\circ}\text{C}$  max
- Low Power Consumption: 15 mW Typical at 5V
- Wide Dynamic Range, 100 dB min at 10 kHz Full Scale Frequency
- Wide Range of Full Scale Frequency: 1 Hz to 100 kHz
- Low Cost

### DESCRIPTION

The LM231/LM331 family of voltage-to-frequency converters are ideally suited for use in simple low-cost circuits for analog-to-digital conversion, precision frequency-to-voltage conversion, long-term integration, linear frequency modulation or demodulation, and many other functions. The output when used as a voltage-to-frequency converter is a pulse train at a frequency precisely proportional to the applied input voltage. Thus, it provides all the inherent advantages of the voltage-to-frequency conversion techniques, and is easy to apply in all standard voltage-to-frequency converter applications. Further, the LM231A/LM331A attain a new high level of accuracy versus temperature which could only be attained with expensive voltage-to-frequency modules. Additionally the LM231/331 are ideally suited for use in digital systems at low power supply voltages and can provide low-cost analog-to-digital conversion in microprocessor-controlled systems. And, the frequency from a battery powered voltage-to-frequency converter can be easily channeled through a simple photo isolator to provide isolation against high common mode levels.

The LM231/LM331 utilize a new temperature-compensated band-gap reference circuit, to provide excellent accuracy over the full operating temperature range, at power supplies as low as 4.0V. The precision timer circuit has low bias currents without degrading the quick response necessary for 100 kHz voltage-to-frequency conversion. And the output are capable of driving 3 TTL loads, or a high voltage output up to 40V, yet is short-circuit-proof against  $V_{CC}$ .

### CONNECTION DIAGRAM

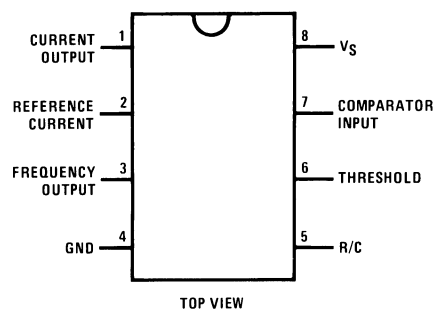

**Figure 1. Plastic Dual-In-Line Package (PDIP)  
See Package Number P (R-PDIP-T8)**



Please be aware that an important notice concerning availability, standard warranty, and use in critical applications of Texas Instruments semiconductor products and disclaimers thereto appears at the end of this data sheet.

Teflon is a registered trademark of E.

All other trademarks are the property of their respective owners.



These devices have limited built-in ESD protection. The leads should be shorted together or the device placed in conductive foam during storage or handling to prevent electrostatic damage to the MOS gates.

### Absolute Maximum Ratings<sup>(1)(2)(3)</sup>

Supply Voltage, $V_S$	40V
Output Short Circuit to Ground	Continuous
Output Short Circuit to $V_{CC}$	Continuous
Input Voltage	-0.2V to $+V_S$
Package Dissipation at 25°C	1.25W <sup>(4)</sup>
Lead Temperature (Soldering, 10 sec.)	
PDIP	260°C
ESD Susceptibility <sup>(5)</sup>	500V

- (1) Absolute Maximum Ratings indicate limits beyond which damage to the device may occur. DC and AC electrical specifications do not apply when operating the device beyond its specified operating conditions.
- (2) All voltages are measured with respect to GND = 0V, unless otherwise noted.
- (3) If Military/Aerospace specified devices are required, please contact the TI Sales Office/Distributors for availability and specifications.
- (4) The absolute maximum junction temperature ( $T_{Jmax}$ ) for this device is 150°C. The maximum allowable power dissipation is dictated by  $T_{Jmax}$ , the junction-to-ambient thermal resistance ( $\theta_{JA}$ ), and the ambient temperature  $T_A$ , and can be calculated using the formula  $P_{Dmax} = (T_{Jmax} - T_A) / \theta_{JA}$ . The values for maximum power dissipation will be reached only when the device is operated in a severe fault condition (e.g., when input or output pins are driven beyond the power supply voltages, or the power supply polarity is reversed). Obviously, such conditions should always be avoided.
- (5) Human body model, 100 pF discharged through a 1.5 k $\Omega$  resistor.

### Operating Ratings<sup>(1)</sup>

Operating Ambient Temperature	
LM231, LM231A	-25°C to +85°C
LM331, LM331A	0°C to +70°C
Supply Voltage, $V_S$	+4V to +40V

- (1) All voltages are measured with respect to GND = 0V, unless otherwise noted.

### Package Thermal Resistance

Package	$\theta_{JA}$
8-Lead PDIP	100°C/W

### Electrical Characteristics

All specifications apply in the circuit of [Figure 16](#), with  $4.0V \leq V_S \leq 40V$ ,  $T_A=25^\circ\text{C}$ , unless otherwise specified.

Parameter	Conditions	Min	Typ	Max	Units
VFC Non-Linearity <sup>(1)</sup>	$4.5V \leq V_S \leq 20V$		$\pm 0.003$	$\pm 0.01$	% Full- Scale
	$T_{MIN} \leq T_A \leq T_{MAX}$		$\pm 0.006$	$\pm 0.02$	% Full- Scale
VFC Non-Linearity in Circuit of <a href="#">Figure 15</a>	$V_S = 15V$ , $f = 10 \text{ Hz to } 11 \text{ kHz}$		$\pm 0.024$	$\pm 0.14$	% Full- Scale
Conversion Accuracy Scale Factor (Gain)					
LM231, LM231A	$V_{IN} = -10V$ , $R_S = 14 \text{ k}\Omega$	0.95	1.00	1.05	kHz/V
LM331, LM331A		0.90	1.00	1.10	kHz/V
Temperature Stability of Gain					
LM231/LM331	$T_{MIN} \leq T_A \leq T_{MAX}$ , $4.5V \leq V_S \leq 20V$		$\pm 30$	$\pm 150$	ppm/°C
LM231A/LM331A			$\pm 20$	$\pm 50$	ppm/°C
Change of Gain with $V_S$	$4.5V \leq V_S \leq 10V$		0.01	0.1	%/V
	$10V \leq V_S \leq 40V$		0.006	0.06	%/V
Rated Full-Scale Frequency	$V_{IN} = -10V$	10.0			kHz
Gain Stability vs. Time (1000 Hours)	$T_{MIN} \leq T_A \leq T_{MAX}$		$\pm 0.02$		% Full- Scale

- (1) Nonlinearity is defined as the deviation of  $f_{OUT}$  from  $V_{IN} \times (10 \text{ kHz}/-10 V_{DC})$  when the circuit has been trimmed for zero error at 10 Hz and at 10 kHz, over the frequency range 1 Hz to 11 kHz. For the timing capacitor,  $C_T$ , use NPO ceramic, Teflon<sup>®</sup>, or polystyrene.

**Electrical Characteristics (continued)**

 All specifications apply in the circuit of [Figure 16](#), with  $4.0V \leq V_S \leq 40V$ ,  $T_A = 25^\circ C$ , unless otherwise specified.

Parameter	Conditions	Min	Typ	Max	Units
Over Range (Beyond Full-Scale) Frequency	$V_{IN} = -11V$	10			%
<b>INPUT COMPARATOR</b>					
Offset Voltage			±3	±10	mV
LM231/LM331	$T_{MIN} \leq T_A \leq T_{MAX}$		±4	±14	mV
LM231A/LM331A	$T_{MIN} \leq T_A \leq T_{MAX}$		±3	±10	mV
Bias Current			-80	-300	nA
Offset Current			±8	±100	nA
Common-Mode Range	$T_{MIN} \leq T_A \leq T_{MAX}$	-0.2		$V_{CC} - 2.0$	V
<b>TIMER</b>					
Timer Threshold Voltage, Pin 5		0.63	0.667	0.70	$\times V_S$
Input Bias Current, Pin 5	$V_S = 15V$				
All Devices	$0V \leq V_{PIN 5} \leq 9.9V$		±10	±100	nA
LM231/LM331	$V_{PIN 5} = 10V$		200	1000	nA
LM231A/LM331A	$V_{PIN 5} = 10V$		200	500	nA
$V_{SAT PIN 5}$ (Reset)	$I = 5 \text{ mA}$		0.22	0.5	V
<b>CURRENT SOURCE (Pin 1)</b>					
Output Current					
LM231, LM231A	$R_S = 14 \text{ k}\Omega$ , $V_{PIN 1} = 0$	126	135	144	µA
LM331, LM331A		116	136	156	µA
Change with Voltage	$0V \leq V_{PIN 1} \leq 10V$		0.2	1.0	µA
Current Source OFF Leakage					
LM231, LM231A, LM331, LM331A			0.02	10.0	nA
All Devices	$T_A = T_{MAX}$		2.0	50.0	nA
Operating Range of Current (Typical)			(10 to 500)		µA
<b>REFERENCE VOLTAGE (Pin 2)</b>					
LM231, LM231A		1.76	1.89	2.02	$V_{DC}$
LM331, LM331A		1.70	1.89	2.08	$V_{DC}$
Stability vs. Temperature			±60		ppm/°C
Stability vs. Time, 1000 Hours			±0.1		%
<b>LOGIC OUTPUT (Pin 3)</b>					
$V_{SAT}$	$I = 5 \text{ mA}$		0.15	0.50	V
	$I = 3.2 \text{ mA}$ (2 TTL Loads), $T_{MIN} \leq T_A \leq T_{MAX}$		0.10	0.40	V
OFF Leakage			±0.05	1.0	µA
<b>SUPPLY CURRENT</b>					
LM231, LM231A	$V_S = 5V$	2.0	3.0	4.0	mA
	$V_S = 40V$	2.5	4.0	6.0	mA
LM331, LM331A	$V_S = 5V$	1.5	3.0	6.0	mA
	$V_S = 40V$	2.0	4.0	8.0	mA

FUNCTIONAL BLOCK DIAGRAM

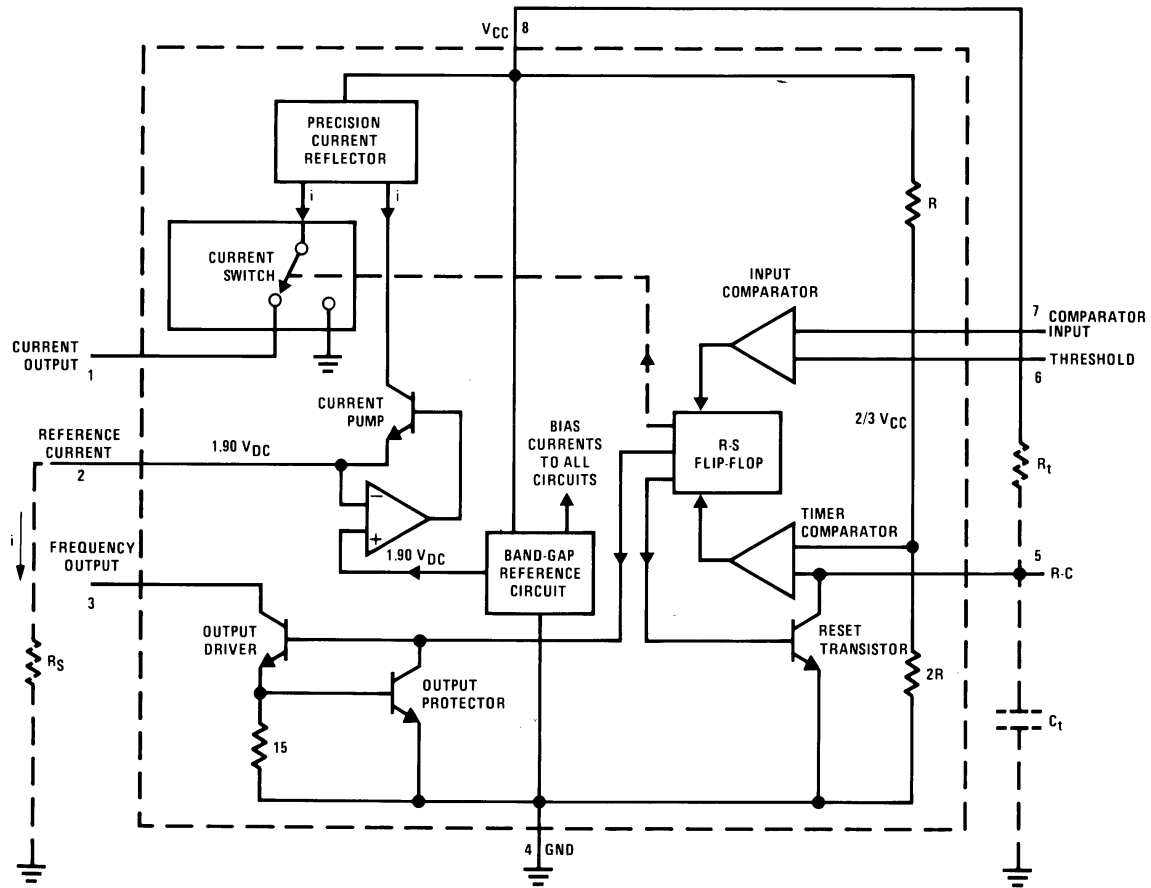

Pin numbers apply to 8-pin packages only.

TYPICAL PERFORMANCE CHARACTERISTICS

(All electrical characteristics apply for the circuit of Figure 16, unless otherwise noted.)

Nonlinearity Error as Precision V-to-F Converter (Figure 16)

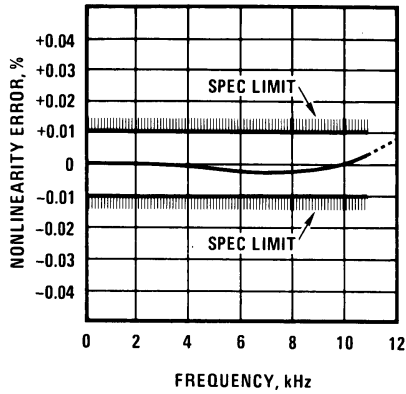

Figure 2.

Nonlinearity Error

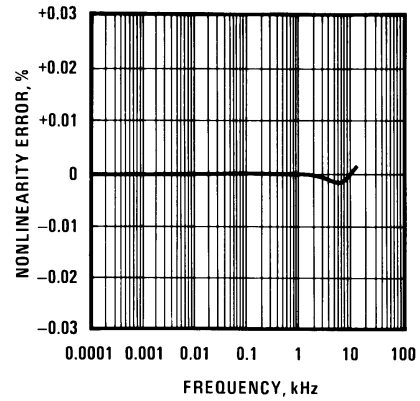

Figure 3.

Nonlinearity Error vs. Power Supply Voltage

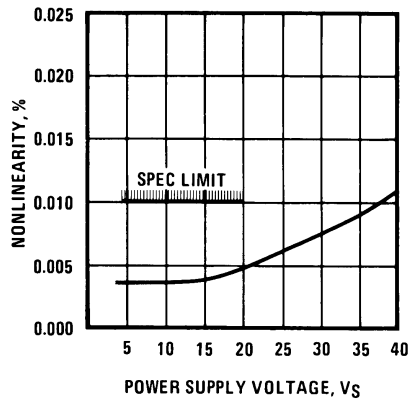

Figure 4.

Frequency vs. Temperature

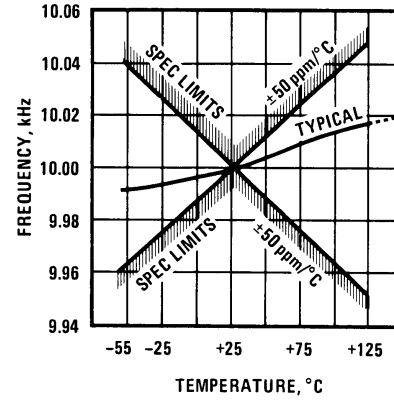

Figure 5.

V<sub>REF</sub> vs. Temperature

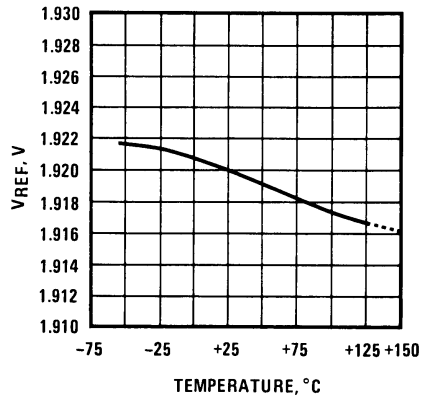

Figure 6.

Output Frequency vs. V<sub>SUPPLY</sub>

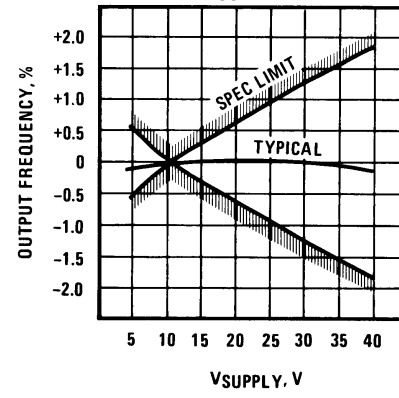

Figure 7.

**TYPICAL PERFORMANCE CHARACTERISTICS (continued)**

(All electrical characteristics apply for the circuit of [Figure 16](#), unless otherwise noted.)

**100 kHz Nonlinearity Error**  
([Figure 17](#))

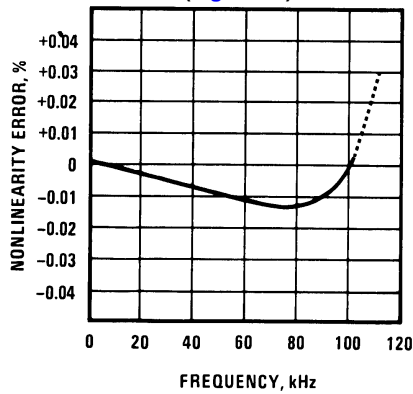

Figure 8.

**Nonlinearity Error**  
([Figure 15](#))

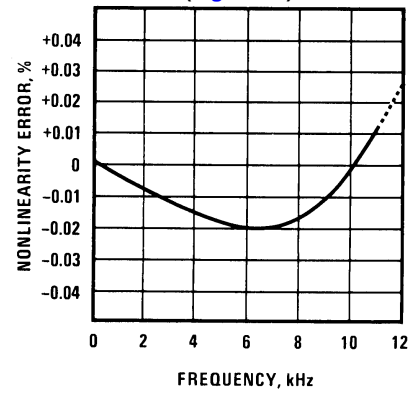

Figure 9.

**Input Current (Pins 6,7) vs. Temperature**

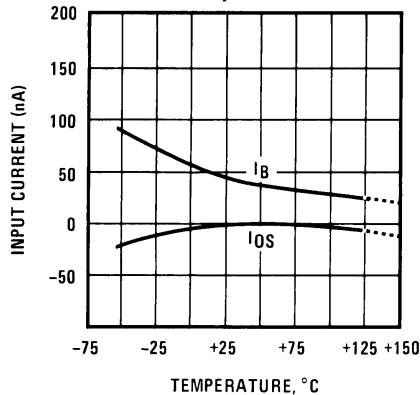

Figure 10.

**Power Drain vs. V<sub>SUPPLY</sub>**

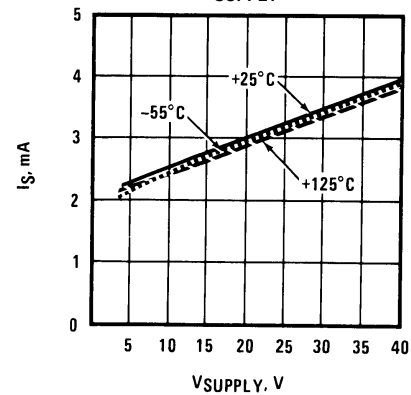

Figure 11.

**Output Saturation Voltage vs. I<sub>OUT</sub> (Pin 3)**

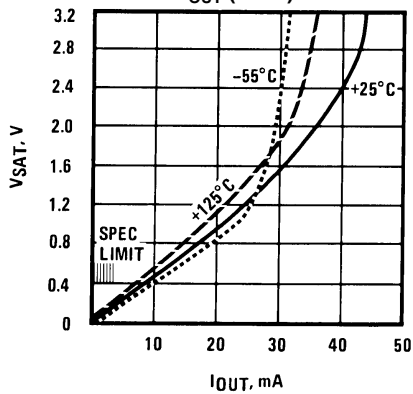

Figure 12.

**Nonlinearity Error, Precision F-to-V Converter**  
([Figure 19](#))

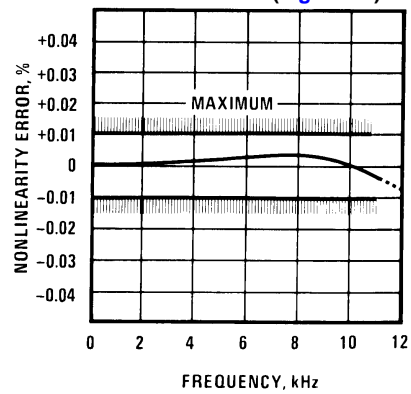
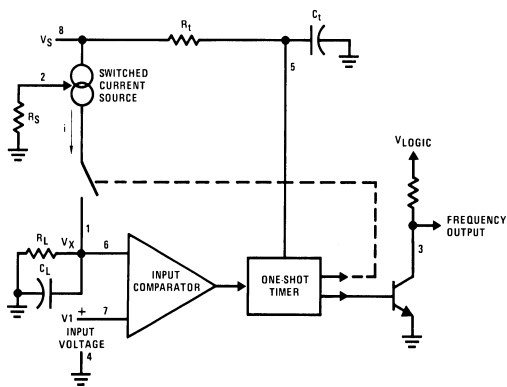

Figure 13.

## APPLICATIONS INFORMATION

### PRINCIPLES OF OPERATION

The LM231/331 are monolithic circuits designed for accuracy and versatile operation when applied as voltage-to-frequency (V-to-F) converters or as frequency-to-voltage (F-to-V) converters. A simplified block diagram of the LM231/331 is shown in Figure 14 and consists of a switched current source, input comparator, and 1-shot timer.



**Figure 14. Simplified Block Diagram of Stand-Alone Voltage-to-Frequency Converter and External Components**

#### Simplified Voltage-to-Frequency Converter

The operation of these blocks is best understood by going through the operating cycle of the basic V-to-F converter, Figure 14, which consists of the simplified block diagram of the LM231/331 and the various resistors and capacitors connected to it.

The voltage comparator compares a positive input voltage,  $V_1$ , at pin 7 to the voltage,  $V_x$ , at pin 6. If  $V_1$  is greater, the comparator will trigger the 1-shot timer. The output of the timer will turn ON both the frequency output transistor and the switched current source for a period  $t = 1.1 R_T C_T$ . During this period, the current  $i$  will flow out of the switched current source and provide a fixed amount of charge,  $Q = i \times t$ , into the capacitor,  $C_L$ . This will normally charge  $V_x$  up to a higher level than  $V_1$ . At the end of the timing period, the current  $i$  will turn OFF, and the timer will reset itself.

Now there is no current flowing from pin 1, and the capacitor  $C_L$  will be gradually discharged by  $R_L$  until  $V_x$  falls to the level of  $V_1$ . Then the comparator will trigger the timer and start another cycle.

The current flowing into  $C_L$  is exactly  $I_{AVE} = i \times (1.1 \times R_T C_T) \times f$ , and the current flowing out of  $C_L$  is exactly  $V_x / R_L \approx V_{IN} / R_L$ . If  $V_{IN}$  is doubled, the frequency will double to maintain this balance. Even a simple V-to-F converter can provide a frequency precisely proportional to its input voltage over a wide range of frequencies.

#### Detail of Operation, Functional Block Diagram

The block diagram (FUNCTIONAL BLOCK DIAGRAM) shows a band gap reference which provides a stable 1.9  $V_{DC}$  output. This 1.9  $V_{DC}$  is well regulated over a  $V_S$  range of 3.9V to 40V. It also has a flat, low temperature coefficient, and typically changes less than 1/2% over a 100°C temperature change.

The current pump circuit forces the voltage at pin 2 to be at 1.9V, and causes a current  $i = 1.90V / R_S$  to flow. For  $R_S = 14k$ ,  $i = 135 \mu A$ . The precision current reflector provides a current equal to  $i$  to the current switch. The current switch switches the current to pin 1 or to ground, depending upon the state of the  $R_S$  flip-flop.

The timing function consists of an  $R_S$  flip-flop and a timer comparator connected to the external  $R_T C_T$  network. When the input comparator detects a voltage at pin 7 higher than pin 6, it sets the  $R_S$  flip-flop which turns ON the current switch and the output driver transistor. When the voltage at pin 5 rises to  $2/3 V_{CC}$ , the timer comparator causes the  $R_S$  flip-flop to reset. The reset transistor is then turned ON and the current switch is turned OFF.

However, if the input comparator still detects pin 7 higher than pin 6 when pin 5 crosses  $\frac{2}{3} V_{CC}$ , the flip-flop will not be reset, and the current at pin 1 will continue to flow, trying to make the voltage at pin 6 higher than pin 7. This condition will usually apply under start-up conditions or in the case of an overload voltage at signal input. During this sort of overload the output frequency will be 0. As soon as the signal is restored to the working range, the output frequency will be resumed.

The output driver transistor acts to saturate pin 3 with an ON resistance of about 50Ω. In case of over voltage, the output current is actively limited to less than 50 mA.

The voltage at pin 2 is regulated at 1.90 V<sub>DC</sub> for all values of  $i$  between 10 μA to 500 μA. It can be used as a voltage reference for other components, but care must be taken to ensure that current is not taken from it which could reduce the accuracy of the converter.

### Basic Voltage-to-Frequency Converter (Figure 15)

The simple stand-alone V-to-F converter shown in Figure 15 includes all the basic circuitry of Figure 14 plus a few components for improved performance.

A resistor,  $R_{IN}=100\text{ k}\Omega \pm 10\%$ , has been added in the path to pin 7, so that the bias current at pin 7 (–80 nA typical) will cancel the effect of the bias current at pin 6 and help provide minimum frequency offset.

The resistance  $R_S$  at pin 2 is made up of a 12 kΩ fixed resistor plus a 5 kΩ (cermet, preferably) gain adjust rheostat. The function of this adjustment is to trim out the gain tolerance of the LM231/331, and the tolerance of  $R_t$ ,  $R_L$  and  $C_t$ .

For best results, all the components should be stable low-temperature-coefficient components, such as metal-film resistors. The capacitor should have low dielectric absorption; depending on the temperature characteristics desired, NPO ceramic, polystyrene, Teflon or polypropylene are best suited.

A capacitor  $C_{IN}$  is added from pin 7 to ground to act as a filter for  $V_{IN}$ . A value of 0.01 μF to 0.1 μF will be adequate in most cases; however, in cases where better filtering is required, a 1 μF capacitor can be used. When the RC time constants are matched at pin 6 and pin 7, a voltage step at  $V_{IN}$  will cause a step change in  $f_{OUT}$ . If  $C_{IN}$  is much less than  $C_L$ , a step at  $V_{IN}$  may cause  $f_{OUT}$  to stop momentarily.

A 47Ω resistor, in series with the 1 μF  $C_L$ , provides hysteresis, which helps the input comparator provide the excellent linearity.

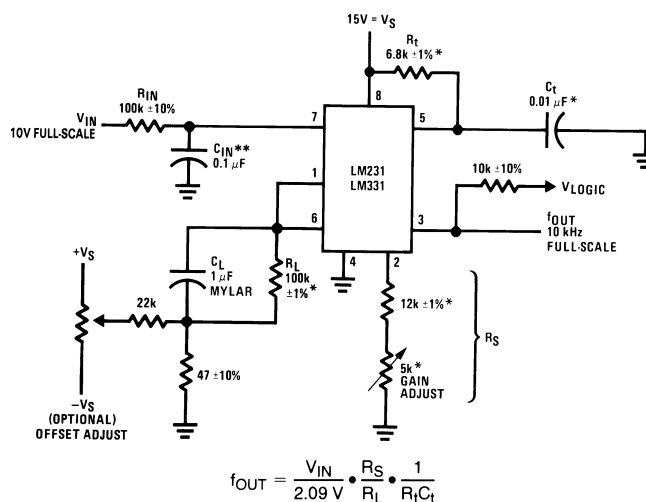

\*Use stable components with low temperature coefficients. See [APPLICATIONS INFORMATION](#).

\*\*0.1μF or 1μF, See [PRINCIPLES OF OPERATION](#).

**Figure 15. Simple Stand-Alone V-to-F Converter with ±0.03% Typical Linearity (f = 10 Hz to 11 kHz)**

**Details of Operation: Precision V-To-F Converter (Figure 16)**

In this circuit, integration is performed by using a conventional operational amplifier and feedback capacitor,  $C_F$ . When the integrator's output crosses the nominal threshold level at pin 6 of the LM231/331, the timing cycle is initiated.

The average current fed into the op-amp's summing point (pin 2) is  $i \times (1.1 R_i C_i) \times f$  which is perfectly balanced with  $-V_{IN}/R_{IN}$ . In this circuit, the voltage offset of the LM231/331 input comparator does not affect the offset or accuracy of the V-to-F converter as it does in the stand-alone V-to-F converter; nor does the LM231/331 bias current or offset current. Instead, the offset voltage and offset current of the operational amplifier are the only limits on how small the signal can be accurately converted. Since op-amps with voltage offset well below 1 mV and offset currents well below 2 nA are available at low cost, this circuit is recommended for best accuracy for small signals. This circuit also responds immediately to any change of input signal (which a stand-alone circuit does not) so that the output frequency will be an accurate representation of  $V_{IN}$ , as quickly as 2 output pulses' spacing can be measured.

In the precision mode, excellent linearity is obtained because the current source (pin 1) is always at ground potential and that voltage does not vary with  $V_{IN}$  or  $f_{OUT}$ . (In the stand-alone V-to-F converter, a major cause of non-linearity is the output impedance at pin 1 which causes  $i$  to change as a function of  $V_{IN}$ ).

The circuit of Figure 17 operates in the same way as Figure 16, but with the necessary changes for high speed operation.

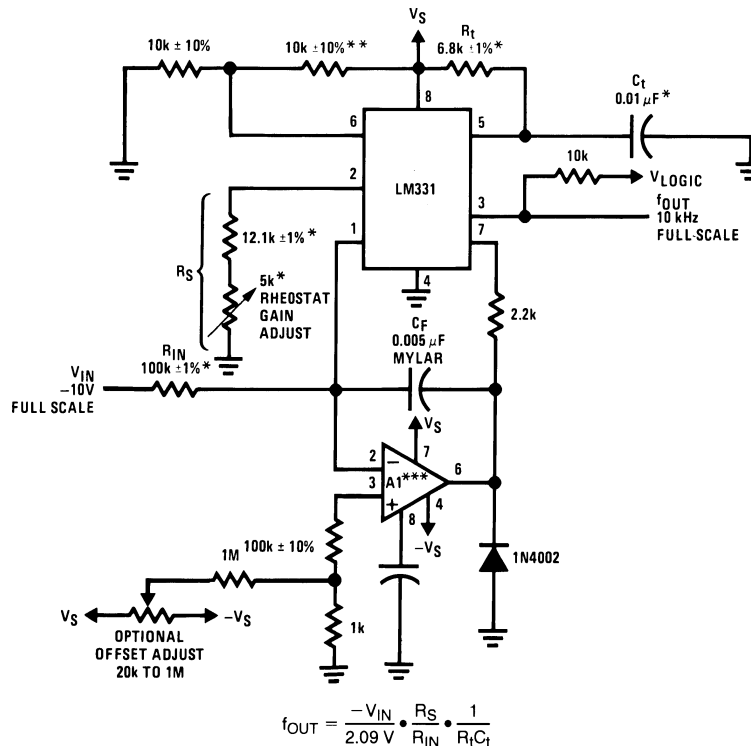

\*Use stable components with low temperature coefficients. See APPLICATIONS INFORMATION.

\*\*This resistor can be 5 kΩ or 10 kΩ for  $V_S=8V$  to 22V, but must be 10 kΩ for  $V_S=4.5V$  to 8V.

\*\*\*Use low offset voltage and low offset current op-amps for A1: recommended type LF411A

**Figure 16. Standard Test Circuit and Applications Circuit, Precision Voltage-to-Frequency Converter**

**DETAILS OF OPERATION: F-to-V CONVERTERS (Figure 18 and Figure 19)**

In these applications, a pulse input at  $f_{IN}$  is differentiated by a C-R network and the negative-going edge at pin 6 causes the input comparator to trigger the timer circuit. Just as with a V-to-F converter, the average current flowing out of pin 1 is  $I_{AVERAGE} = i \times (1.1 R_i C_i) \times f$ .

In the simple circuit of Figure 18, this current is filtered in the network  $R_L = 100\text{ k}\Omega$  and  $1\text{ }\mu\text{F}$ . The ripple will be less than 10 mV peak, but the response will be slow, with a 0.1 second time constant, and settling of 0.7 second to 0.1% accuracy.

In the precision circuit, an operational amplifier provides a buffered output and also acts as a 2-pole filter. The ripple will be less than 5 mV peak for all frequencies above 1 kHz, and the response time will be much quicker than in Figure 18. However, for input frequencies below 200 Hz, this circuit will have worse ripple than Figure 18. The engineering of the filter time-constants to get adequate response and small enough ripple simply requires a study of the compromises to be made. Inherently, V-to-F converter response can be fast, but F-to-V response can not.

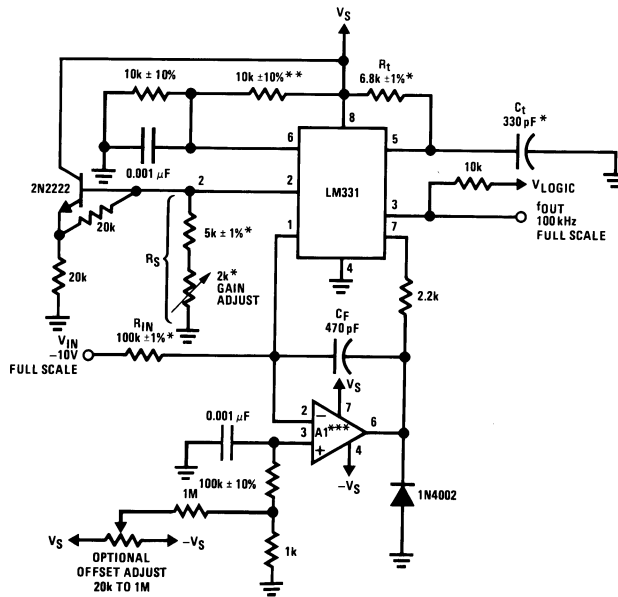

- \*Use stable components with low temperature coefficients. See APPLICATIONS INFORMATION.
- \*\*This resistor can be 5 kΩ or 10 kΩ for  $V_S=8\text{V}$  to 22V, but must be 10 kΩ for  $V_S=4.5\text{V}$  to 8V.
- \*\*\*Use low offset voltage and low offset current op-amps for A1: recommended types LF411A or LF356.

**Figure 17. Precision Voltage-to-Frequency Converter, 100 kHz Full-Scale, ±0.03% Non-Linearity**

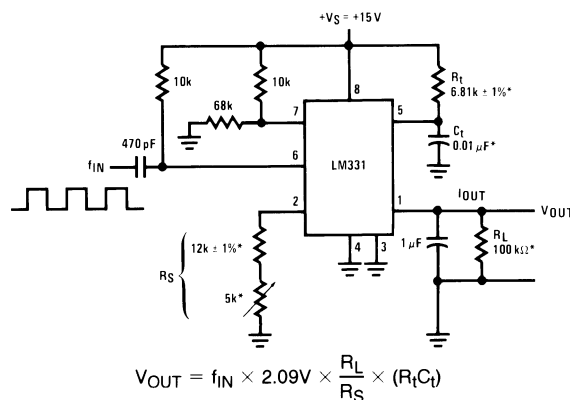

- \*Use stable components with low temperature coefficients.

**Figure 18. Simple Frequency-to-Voltage Converter, 10 kHz Full-Scale, ±0.06% Non-Linearity**

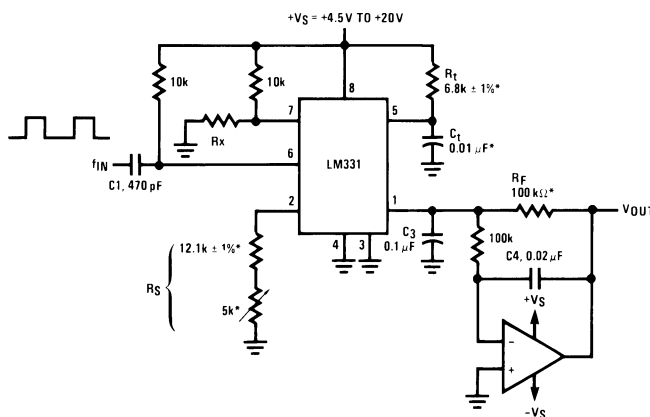

$$V_{OUT} = -f_{IN} \times 2.09V \times \frac{R_F}{R_S} \times (R_T C_T)$$

$$\text{SELECT } R_x = \frac{(V_S - 2V)}{0.2 \text{ mA}}$$

\*Use stable components with low temperature coefficients.

**Figure 19. Precision Frequency-to-Voltage Converter, 10 kHz Full-Scale with 2-Pole Filter, ±0.01% Non-Linearity Maximum**

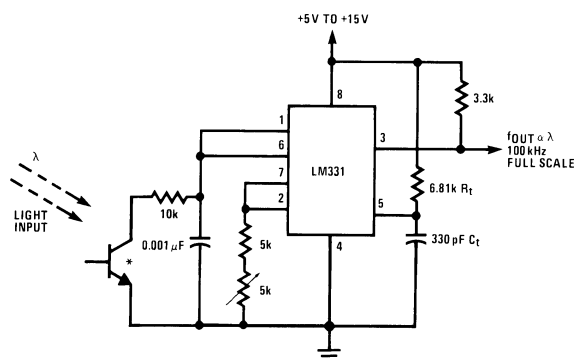

\*L14F-1, L14G-1 or L14H-1, photo transistor (General Electric Co.) or similar

**Figure 20. Light Intensity to Frequency Converter**

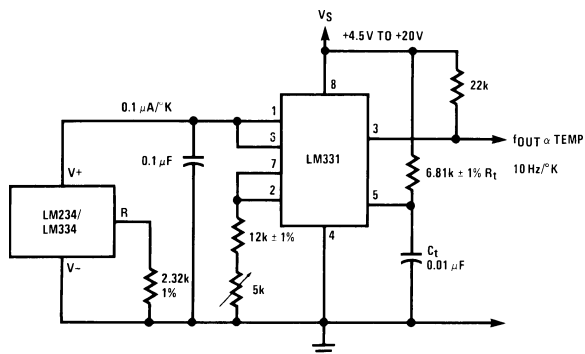

**Figure 21. Temperature to Frequency Converter**

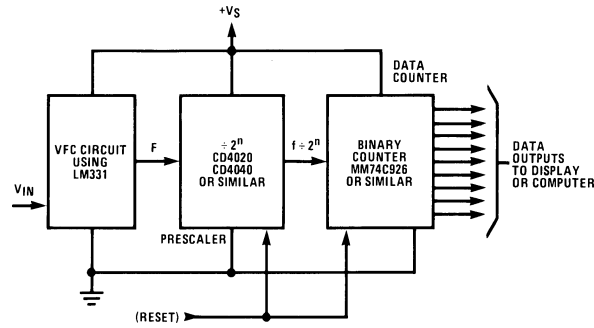

Figure 22. Long-Term Digital Integrator Using VFC

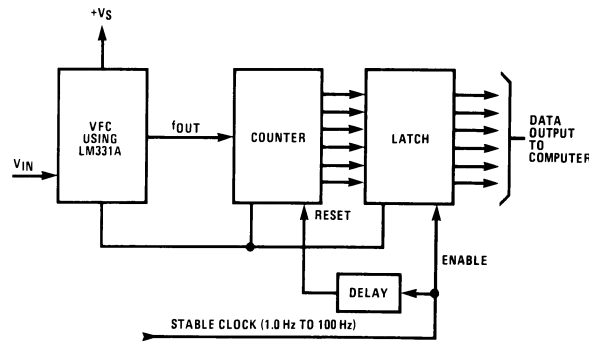

Figure 23. Basic Analog-to-Digital Converter Using Voltage-to-Frequency Converter

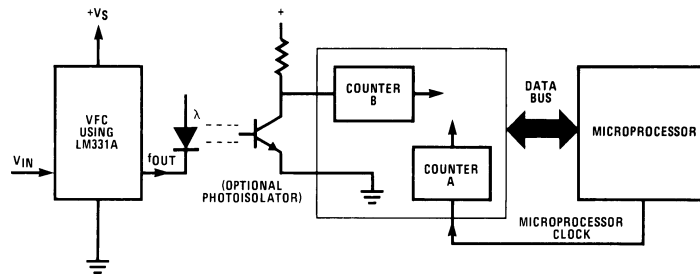

Figure 24. Analog-to-Digital Converter with Microprocessor

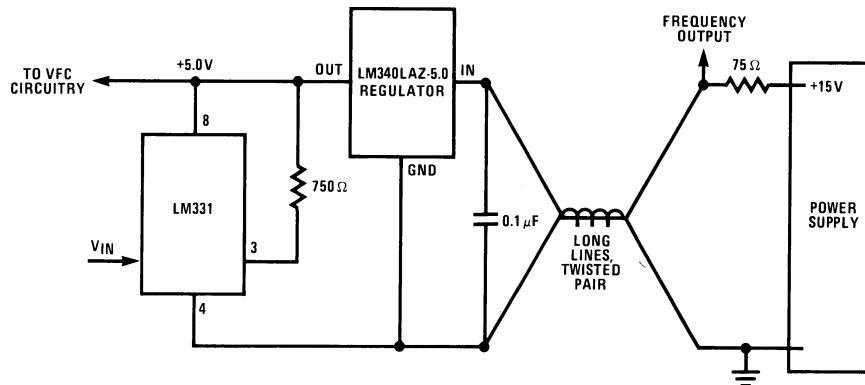

Figure 25. Remote Voltage-to-Frequency Converter with 2-Wire Transmitter and Receiver

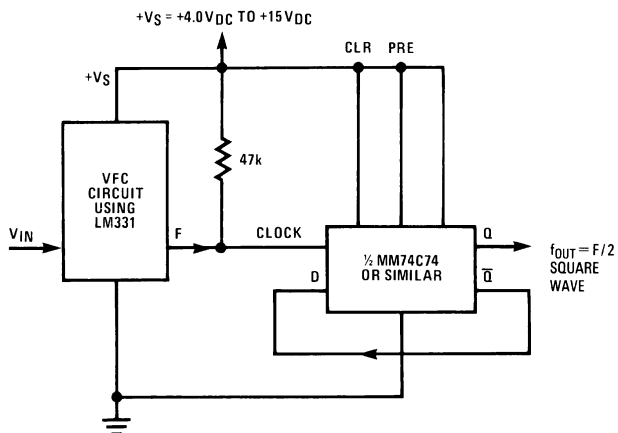

Figure 26. Voltage-to-Frequency Converter with Square-Wave Output Using  $\div 2$  Flip-Flop

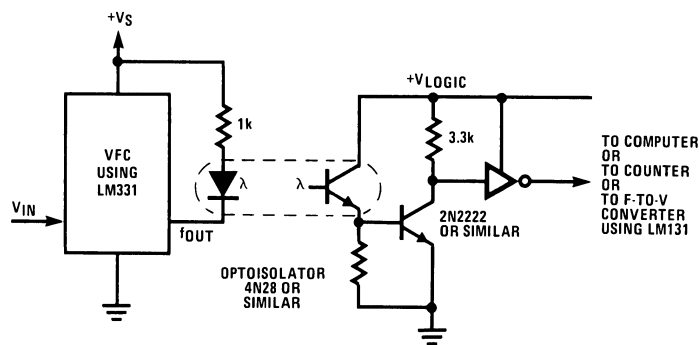

Figure 27. Voltage-to-Frequency Converter with Isolators

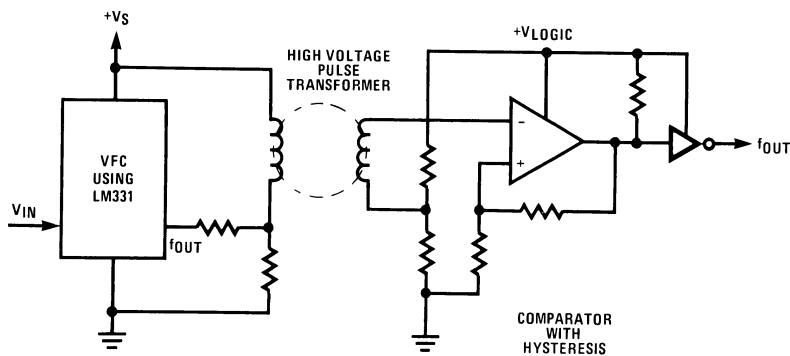

Figure 28. Voltage-to-Frequency Converter with Isolators

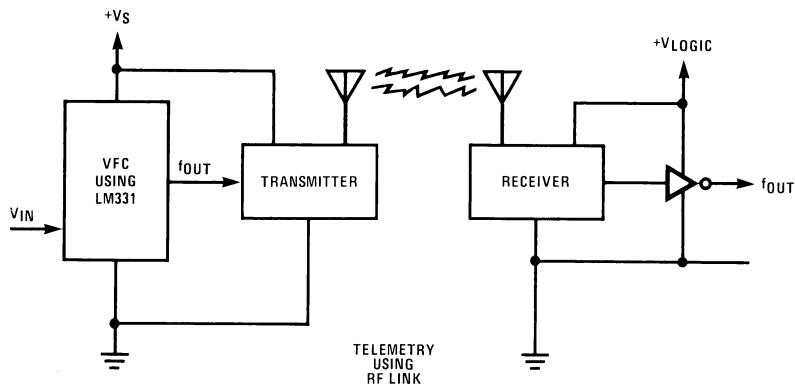

Figure 29. Voltage-to-Frequency Converter with Isolators

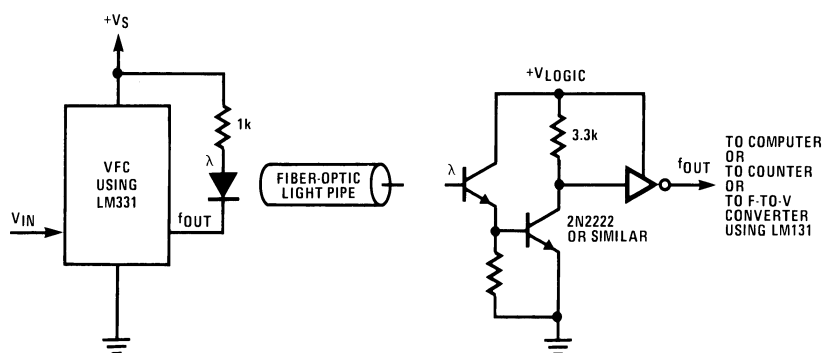
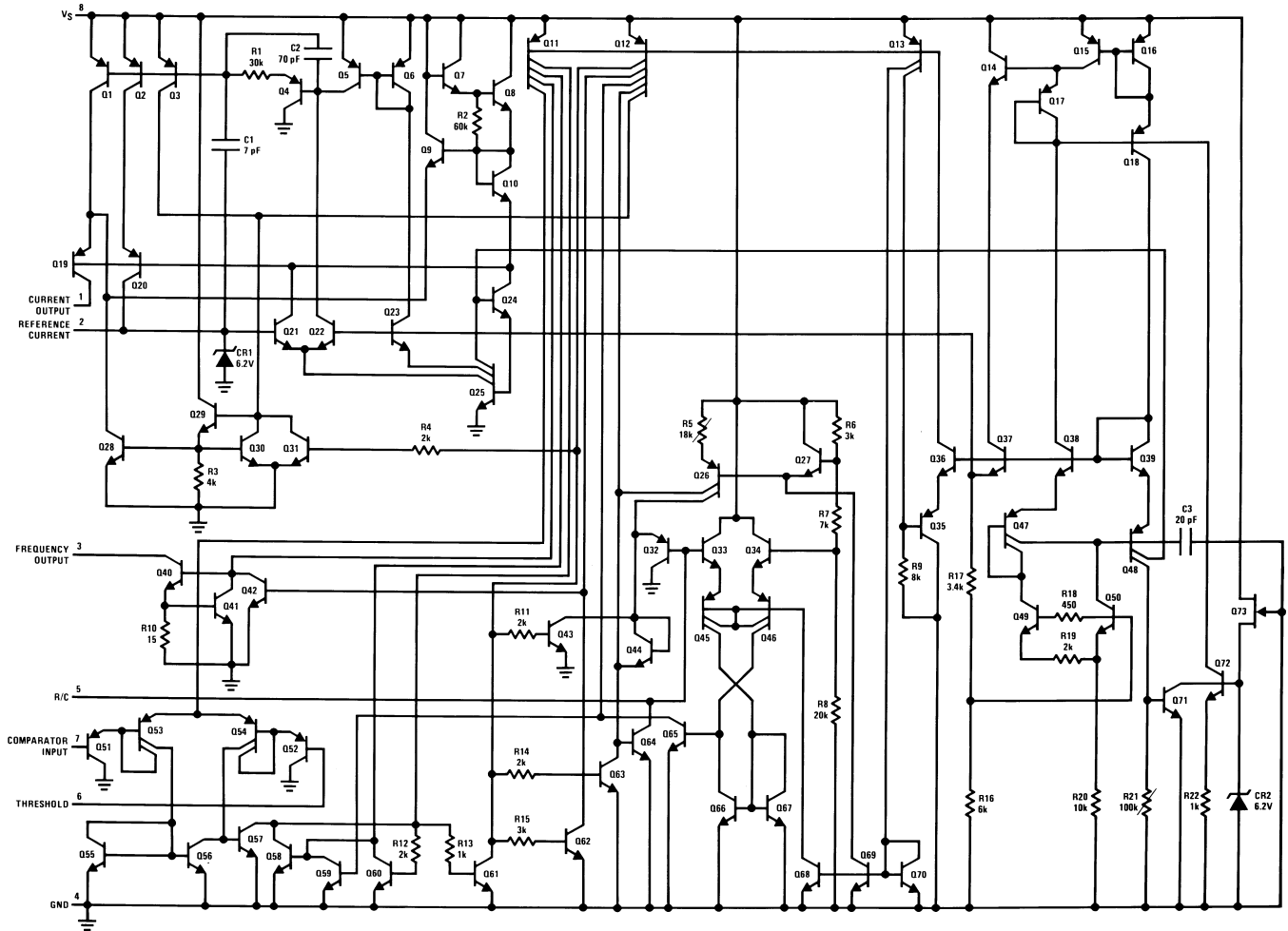

Figure 30. Voltage-to-Frequency Converter with Isolators

Schematic Diagram



## REVISION HISTORY

Changes from Revision A (March 2013) to Revision B	Page
• Changed layout of National Data Sheet to TI format .....	<a href="#">15</a>

**PACKAGING INFORMATION**

Orderable Device	Status (1)	Package Type	Package Drawing	Pins	Package Qty	Eco Plan (2)	Lead/Ball Finish (6)	MSL Peak Temp (3)	Op Temp (°C)	Device Marking (4/5)	Samples
LM231AN	NRND	PDIP	P	8	40	TBD	Call TI	Call TI	-25 to 85	LM 231AN	
LM231AN/NOPB	ACTIVE	PDIP	P	8	40	Green (RoHS & no Sb/Br)	CU SN	Level-1-NA-UNLIM	-25 to 85	LM 231AN	<b>Samples</b>
LM231N	NRND	PDIP	P	8	40	TBD	Call TI	Call TI	-25 to 85	LM 231N	
LM231N/NOPB	ACTIVE	PDIP	P	8	40	Green (RoHS & no Sb/Br)	CU SN	Level-1-NA-UNLIM	-25 to 85	LM 231N	<b>Samples</b>
LM331AN	NRND	PDIP	P	8	40	TBD	Call TI	Call TI		LM 331AN	
LM331AN/NOPB	ACTIVE	PDIP	P	8	40	Green (RoHS & no Sb/Br)	CU SN	Level-1-NA-UNLIM		LM 331AN	<b>Samples</b>
LM331N	NRND	PDIP	P	8	40	TBD	Call TI	Call TI	0 to 70	LM 331N	
LM331N/NOPB	ACTIVE	PDIP	P	8	40	Green (RoHS & no Sb/Br)	CU SN	Level-1-NA-UNLIM	0 to 70	LM 331N	<b>Samples</b>
RC4151NB	NRND	PDIP	P	8	40	TBD	Call TI	Call TI	0 to 70	LM 331N	
RV4151NB	NRND	PDIP	P	8	40	TBD	Call TI	Call TI	-25 to 85	LM 231N	

(1) The marketing status values are defined as follows:

**ACTIVE:** Product device recommended for new designs.

**LIFEBUY:** TI has announced that the device will be discontinued, and a lifetime-buy period is in effect.

**NRND:** Not recommended for new designs. Device is in production to support existing customers, but TI does not recommend using this part in a new design.

**PREVIEW:** Device has been announced but is not in production. Samples may or may not be available.

**OBSOLETE:** TI has discontinued the production of the device.

(2) Eco Plan - The planned eco-friendly classification: Pb-Free (RoHS), Pb-Free (RoHS Exempt), or Green (RoHS & no Sb/Br) - please check <http://www.ti.com/productcontent> for the latest availability information and additional product content details.

**TBD:** The Pb-Free/Green conversion plan has not been defined.

**Pb-Free (RoHS):** TI's terms "Lead-Free" or "Pb-Free" mean semiconductor products that are compatible with the current RoHS requirements for all 6 substances, including the requirement that lead not exceed 0.1% by weight in homogeneous materials. Where designed to be soldered at high temperatures, TI Pb-Free products are suitable for use in specified lead-free processes.

**Pb-Free (RoHS Exempt):** This component has a RoHS exemption for either 1) lead-based flip-chip solder bumps used between the die and package, or 2) lead-based die adhesive used between the die and leadframe. The component is otherwise considered Pb-Free (RoHS compatible) as defined above.

**Green (RoHS & no Sb/Br):** TI defines "Green" to mean Pb-Free (RoHS compatible), and free of Bromine (Br) and Antimony (Sb) based flame retardants (Br or Sb do not exceed 0.1% by weight in homogeneous material)

- (3) MSL, Peak Temp. - The Moisture Sensitivity Level rating according to the JEDEC industry standard classifications, and peak solder temperature.
- (4) There may be additional marking, which relates to the logo, the lot trace code information, or the environmental category on the device.
- (5) Multiple Device Markings will be inside parentheses. Only one Device Marking contained in parentheses and separated by a "~" will appear on a device. If a line is indented then it is a continuation of the previous line and the two combined represent the entire Device Marking for that device.
- (6) Lead/Ball Finish - Orderable Devices may have multiple material finish options. Finish options are separated by a vertical ruled line. Lead/Ball Finish values may wrap to two lines if the finish value exceeds the maximum column width.

**Important Information and Disclaimer:**The information provided on this page represents TI's knowledge and belief as of the date that it is provided. TI bases its knowledge and belief on information provided by third parties, and makes no representation or warranty as to the accuracy of such information. Efforts are underway to better integrate information from third parties. TI has taken and continues to take reasonable steps to provide representative and accurate information but may not have conducted destructive testing or chemical analysis on incoming materials and chemicals. TI and TI suppliers consider certain information to be proprietary, and thus CAS numbers and other limited information may not be available for release.

In no event shall TI's liability arising out of such information exceed the total purchase price of the TI part(s) at issue in this document sold by TI to Customer on an annual basis.

P (R-PDIP-T8)

PLASTIC DUAL-IN-LINE PACKAGE



- NOTES:
- A. All linear dimensions are in inches (millimeters).
  - B. This drawing is subject to change without notice.
  - C. Falls within JEDEC MS-001 variation BA.

## IMPORTANT NOTICE

Texas Instruments Incorporated and its subsidiaries (TI) reserve the right to make corrections, enhancements, improvements and other changes to its semiconductor products and services per JESD46, latest issue, and to discontinue any product or service per JESD48, latest issue. Buyers should obtain the latest relevant information before placing orders and should verify that such information is current and complete. All semiconductor products (also referred to herein as "components") are sold subject to TI's terms and conditions of sale supplied at the time of order acknowledgment.

TI warrants performance of its components to the specifications applicable at the time of sale, in accordance with the warranty in TI's terms and conditions of sale of semiconductor products. Testing and other quality control techniques are used to the extent TI deems necessary to support this warranty. Except where mandated by applicable law, testing of all parameters of each component is not necessarily performed.

TI assumes no liability for applications assistance or the design of Buyers' products. Buyers are responsible for their products and applications using TI components. To minimize the risks associated with Buyers' products and applications, Buyers should provide adequate design and operating safeguards.

TI does not warrant or represent that any license, either express or implied, is granted under any patent right, copyright, mask work right, or other intellectual property right relating to any combination, machine, or process in which TI components or services are used. Information published by TI regarding third-party products or services does not constitute a license to use such products or services or a warranty or endorsement thereof. Use of such information may require a license from a third party under the patents or other intellectual property of the third party, or a license from TI under the patents or other intellectual property of TI.

Reproduction of significant portions of TI information in TI data books or data sheets is permissible only if reproduction is without alteration and is accompanied by all associated warranties, conditions, limitations, and notices. TI is not responsible or liable for such altered documentation. Information of third parties may be subject to additional restrictions.

Resale of TI components or services with statements different from or beyond the parameters stated by TI for that component or service voids all express and any implied warranties for the associated TI component or service and is an unfair and deceptive business practice. TI is not responsible or liable for any such statements.

Buyer acknowledges and agrees that it is solely responsible for compliance with all legal, regulatory and safety-related requirements concerning its products, and any use of TI components in its applications, notwithstanding any applications-related information or support that may be provided by TI. Buyer represents and agrees that it has all the necessary expertise to create and implement safeguards which anticipate dangerous consequences of failures, monitor failures and their consequences, lessen the likelihood of failures that might cause harm and take appropriate remedial actions. Buyer will fully indemnify TI and its representatives against any damages arising out of the use of any TI components in safety-critical applications.

In some cases, TI components may be promoted specifically to facilitate safety-related applications. With such components, TI's goal is to help enable customers to design and create their own end-product solutions that meet applicable functional safety standards and requirements. Nonetheless, such components are subject to these terms.

No TI components are authorized for use in FDA Class III (or similar life-critical medical equipment) unless authorized officers of the parties have executed a special agreement specifically governing such use.

Only those TI components which TI has specifically designated as military grade or "enhanced plastic" are designed and intended for use in military/aerospace applications or environments. Buyer acknowledges and agrees that any military or aerospace use of TI components which have **not** been so designated is solely at the Buyer's risk, and that Buyer is solely responsible for compliance with all legal and regulatory requirements in connection with such use.

TI has specifically designated certain components as meeting ISO/TS16949 requirements, mainly for automotive use. In any case of use of non-designated products, TI will not be responsible for any failure to meet ISO/TS16949.

### Products

Audio	<a href="http://www.ti.com/audio">www.ti.com/audio</a>
Amplifiers	<a href="http://amplifier.ti.com">amplifier.ti.com</a>
Data Converters	<a href="http://dataconverter.ti.com">dataconverter.ti.com</a>
DLP® Products	<a href="http://www.dlp.com">www.dlp.com</a>
DSP	<a href="http://dsp.ti.com">dsp.ti.com</a>
Clocks and Timers	<a href="http://www.ti.com/clocks">www.ti.com/clocks</a>
Interface	<a href="http://interface.ti.com">interface.ti.com</a>
Logic	<a href="http://logic.ti.com">logic.ti.com</a>
Power Mgmt	<a href="http://power.ti.com">power.ti.com</a>
Microcontrollers	<a href="http://microcontroller.ti.com">microcontroller.ti.com</a>
RFID	<a href="http://www.ti-rfid.com">www.ti-rfid.com</a>
OMAP Applications Processors	<a href="http://www.ti.com/omap">www.ti.com/omap</a>
Wireless Connectivity	<a href="http://www.ti.com/wirelessconnectivity">www.ti.com/wirelessconnectivity</a>

### Applications

Automotive and Transportation	<a href="http://www.ti.com/automotive">www.ti.com/automotive</a>
Communications and Telecom	<a href="http://www.ti.com/communications">www.ti.com/communications</a>
Computers and Peripherals	<a href="http://www.ti.com/computers">www.ti.com/computers</a>
Consumer Electronics	<a href="http://www.ti.com/consumer-apps">www.ti.com/consumer-apps</a>
Energy and Lighting	<a href="http://www.ti.com/energy">www.ti.com/energy</a>
Industrial	<a href="http://www.ti.com/industrial">www.ti.com/industrial</a>
Medical	<a href="http://www.ti.com/medical">www.ti.com/medical</a>
Security	<a href="http://www.ti.com/security">www.ti.com/security</a>
Space, Avionics and Defense	<a href="http://www.ti.com/space-avionics-defense">www.ti.com/space-avionics-defense</a>
Video and Imaging	<a href="http://www.ti.com/video">www.ti.com/video</a>

### TI E2E Community

[e2e.ti.com](http://e2e.ti.com)