

LM3302 QUADRUPLE DIFFERENTIAL COMPARATOR

SLCS014A –OCTOBER 1977 –REVISED AUGUST 2003

- Single Supply or Dual Supplies
- Wide Range of Supply Voltage . . . 2 V to 28 V
- Low Supply-Current Drain Independent of Supply Voltage . . . 0.8 mA Typ
- Low Input Bias Current . . . 25 nA Typ
- Low Input Offset Current . . . 3 nA Typ
- Low Input Offset Voltage . . . 3 mV Typ
- Common-Mode Input Voltage Range Includes Ground
- Differential Input Voltage Range Equal to Maximum-Rated Supply Voltage . . . ± 28 V
- Low Output Saturation Voltage
- Output Compatible With TTL, MOS, and CMOS

D OR N PACKAGE
(TOP VIEW)

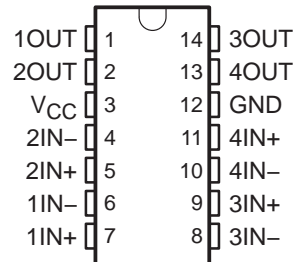

description/ordering information

This device consists of four independent voltage comparators that are designed to operate from a single power supply over a wide range of voltages. Operation from dual supplies also is possible as long as the difference between the two supplies is 2 V to 28 V and V_{CC} is a least 1.5 V more positive than the input common-mode voltage. Current drain is independent of the supply voltage. The outputs can be connected to other open-collector outputs to achieve wired-AND relationships.

ORDERING INFORMATION

T_A	V_{IOmax} AT 25°C	PACKAGE†		ORDERABLE PART NUMBER	TOP-SIDE MARKING
-40°C to 85°C	20 mV	PDIP (N)	Tube of 25	LM3302N	LM3302N
		SOIC (D)	Tube of 50	LM3302D	LM3302
			Reel of 2500	LM3302DR	

† Package drawings, standard packing quantities, thermal data, symbolization, and PCB design guidelines are available at www.ti.com/sc/package.

symbol (each comparator)

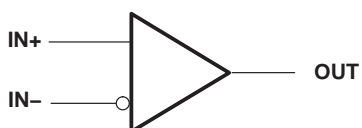

LM3302 QUADRUPLE DIFFERENTIAL COMPARATOR

SLCS014A –OCTOBER 1977 –REVISED AUGUST 2003

schematic

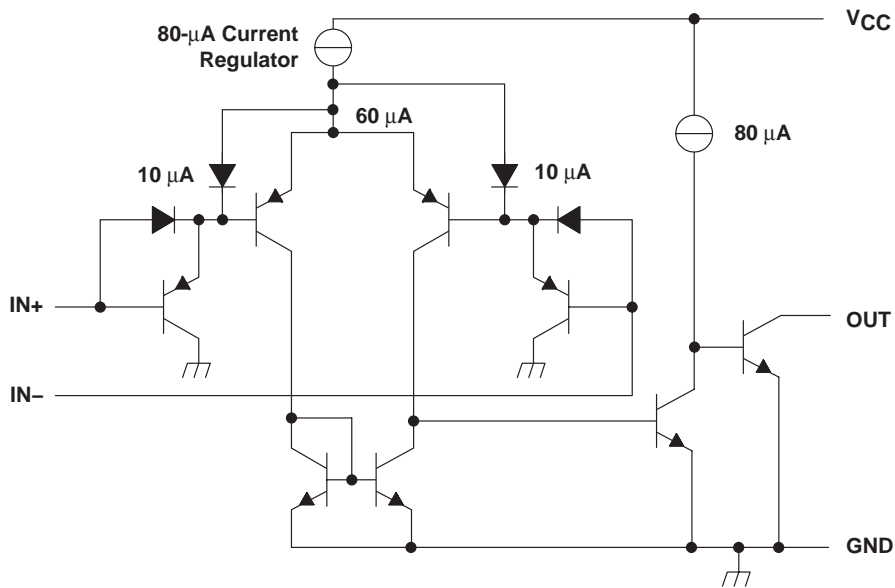

Current values shown are nominal.

absolute maximum ratings over operating free-air temperature range (unless otherwise noted)[†]

Supply voltage, V_{CC} (see Note 1)	28 V
Differential input voltage, V_{ID} (see Note 2)	± 28 V
Input voltage range, V_I (either input)	-0.3 V to 28 V
Output voltage, V_O	28 V
Output current, I_O	20 mA
Duration of output short-circuit to ground (see Note 3)	Unlimited
Package thermal impedance, θ_{JA} (see Notes 4 and 5): D package	86°C/W
N package	80°C/W
Operating virtual junction temperature, T_J	150°C
Lead temperature 1,6 mm (1/16 inch) from case for 10 seconds: D or N package	260°C
Storage temperature range, T_{stg}	-65°C to 150°C

[†] Stresses beyond those listed under absolute maximum ratings may cause permanent damage to the device. There are stress ratings only, and functional operation of the device at these or any other conditions beyond those indicated in the recommended operating conditions section of this specification is not implied. Exposure to absolute-maximum-rated conditions for extended periods may affect device reliability.

- NOTES:
1. All voltage values, except differential voltages, are with respect to the network ground.
 2. Differential voltages are at $IN+$ with respect to $IN-$.
 3. Short circuits from the output to V_{CC} can cause excessive heating and eventual destruction.
 4. Maximum power dissipation is a function of $T_J(max)$, θ_{JA} , and T_A . The maximum allowable power dissipation at any allowable ambient temperature is $P_D = (T_J(max) - T_A)/\theta_{JA}$. Operating at the absolute maximum T_J of 150°C can affect reliability.
 5. The package thermal impedance is calculated in accordance with JESD 51-7.

LM3302 QUADRUPLE DIFFERENTIAL COMPARATOR

SLCS014A –OCTOBER 1977 –REVISED AUGUST 2003

electrical characteristics at specified free-air temperature, $V_{CC} = 5\text{ V}$ (unless otherwise noted)

PARAMETER		TEST CONDITION†	T_A	MIN	TYP	MAX	UNIT	
V_{IO}	Input offset voltage	$V_{CC} = 5\text{ V to } 28\text{ V}, V_{IC} = V_{ICRmin}, V_O = 1.4\text{ V}$	25°C		3	20	mV	
			-40°C to 85°C			40		
I_{IO}	Input offset current	$V_O = 1.4\text{ V}$	25°C		3	100	nA	
			-40°C to 85°C			300		
I_{IB}	Input bias current		25°C		-25	-500	nA	
			-40°C to 85°C			-1000		
V_{ICR}	Common-mode input voltage range		25°C		0 to $V_{CC}-1.5$		V	
			-40°C to 85°C		0 to $V_{CC}-2$			
A_{VD}	Large-signal differential voltage amplification	$V_{CC} = 15\text{ V}, R_L = 15\ \Omega \text{ to } V_{CC}, V_O = 1.4\text{ V to } 11.4\text{ V}$	25°C		2	30	V/mV	
I_{OH}	High-level output current	$V_{ID} = 1\text{ V}, V_{OH} = 5\text{ V}$	25°C			0.1	nA	
			-40°C to 85°C				1	μA
V_{OL}	Low-level output voltage	$V_{ID} = -1\text{ V}, I_{OL} = 4\text{ mA}$	25°C			150	500	mV
			-40°C to 85°C				700	
I_{OL}	Low-level output current	$V_{ID} = 1\text{ V}, V_{OL} = 1.5\text{ V}$	25°C		6	16	mA	
I_{CC}	Supply current (four comparators)	$V_O = 2.5\text{ V}, \text{ No load}$	25°C			0.8	mA	

† All characteristics are measured with zero common-mode input voltage unless otherwise specified.

switching characteristics, $V_{CC} = 5\text{ V}, T_A = 25^\circ\text{C}$

PARAMETER	TEST CONDITIONS	TYP	UNIT
Response time	$R_L = 5.1\text{ k}\Omega \text{ to } 5\text{ V}, C_L = 15\text{ pF}^\ddagger, \text{ See Note 6}$	100-mV input step with 5-mV overdrive	1.3
		TTL-level input step	0.3

‡ C_L includes probe and jig capacitance.

NOTE 6: The response time specified is the interval between the input step function and the instant when the output crosses 1.4 V.



N (R-PDIP-T**)

PLASTIC DUAL-IN-LINE PACKAGE

16 PINS SHOWN

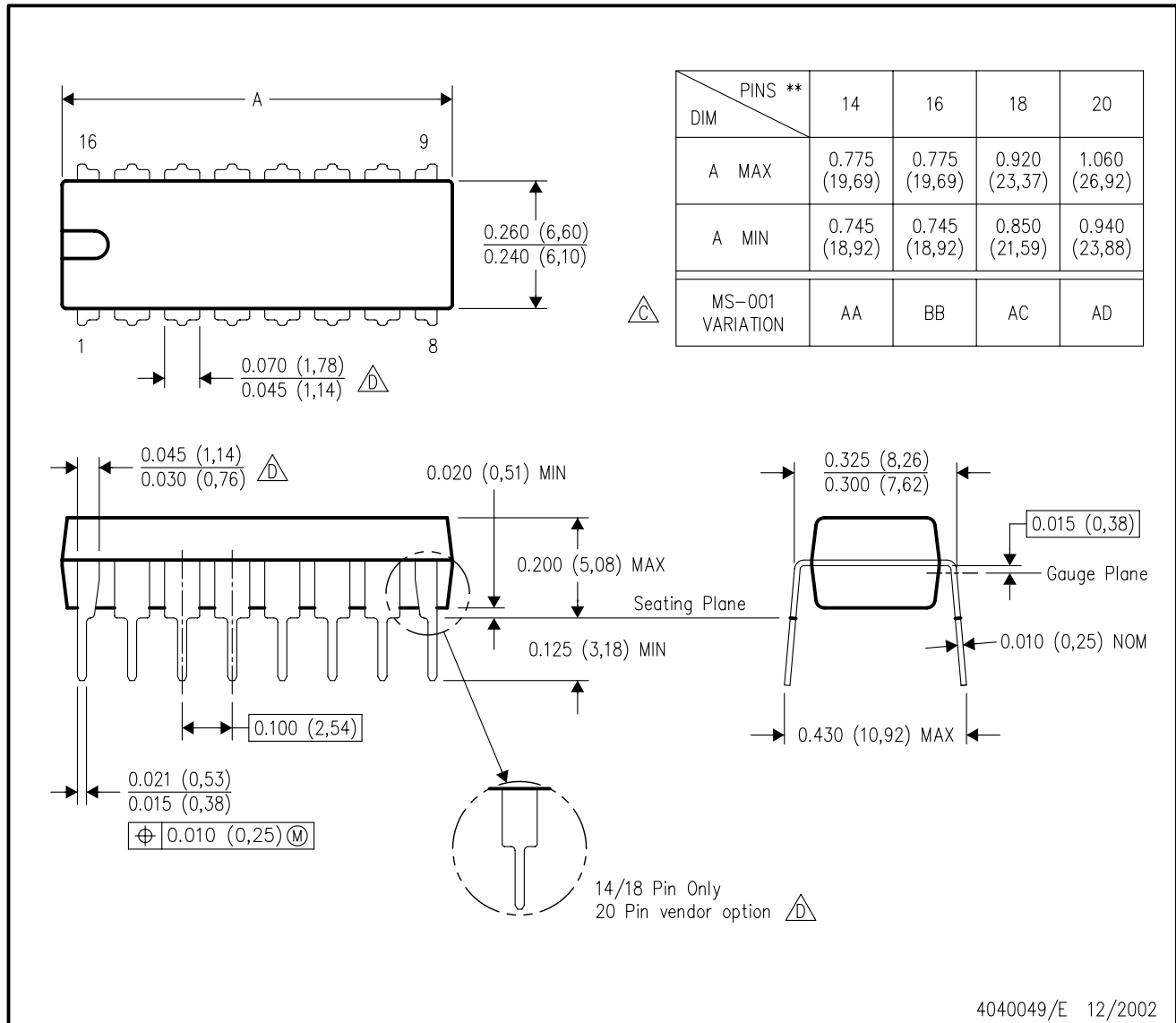

- NOTES:
- A. All linear dimensions are in inches (millimeters).
 - B. This drawing is subject to change without notice.
 - Falls within JEDEC MS-001, except 18 and 20 pin minimum body length (Dim A).
 - The 20 pin end lead shoulder width is a vendor option, either half or full width.

D (R-PDSO-G14)

PLASTIC SMALL-OUTLINE PACKAGE

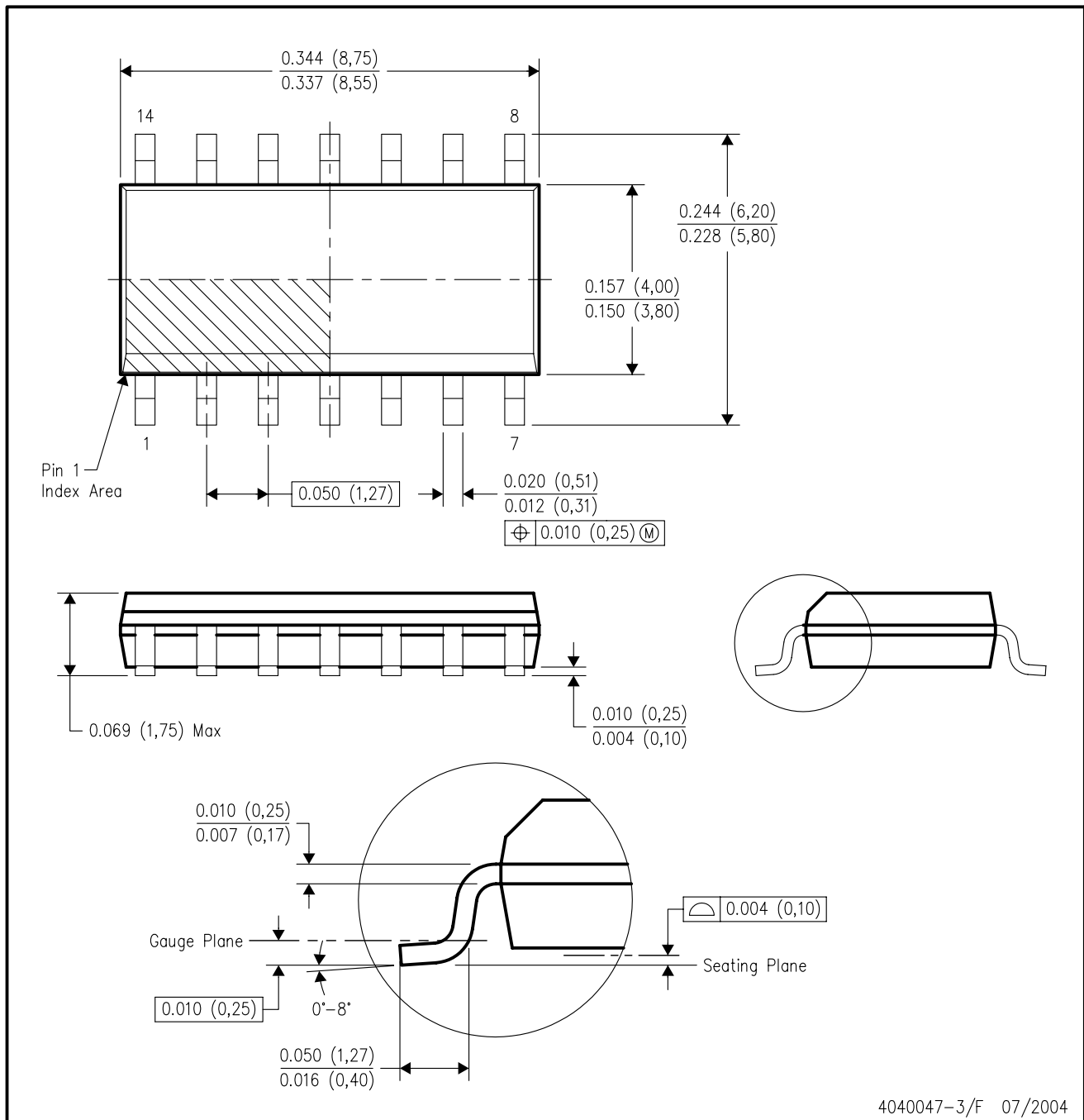

- NOTES:
- A. All linear dimensions are in inches (millimeters).
 - B. This drawing is subject to change without notice.
 - C. Body dimensions do not include mold flash or protrusion not to exceed 0.006 (0,15).
 - D. Falls within JEDEC MS-012 variation AB.

IMPORTANT NOTICE

Texas Instruments Incorporated and its subsidiaries (TI) reserve the right to make corrections, modifications, enhancements, improvements, and other changes to its products and services at any time and to discontinue any product or service without notice. Customers should obtain the latest relevant information before placing orders and should verify that such information is current and complete. All products are sold subject to TI's terms and conditions of sale supplied at the time of order acknowledgment.

TI warrants performance of its hardware products to the specifications applicable at the time of sale in accordance with TI's standard warranty. Testing and other quality control techniques are used to the extent TI deems necessary to support this warranty. Except where mandated by government requirements, testing of all parameters of each product is not necessarily performed.

TI assumes no liability for applications assistance or customer product design. Customers are responsible for their products and applications using TI components. To minimize the risks associated with customer products and applications, customers should provide adequate design and operating safeguards.

TI does not warrant or represent that any license, either express or implied, is granted under any TI patent right, copyright, mask work right, or other TI intellectual property right relating to any combination, machine, or process in which TI products or services are used. Information published by TI regarding third-party products or services does not constitute a license from TI to use such products or services or a warranty or endorsement thereof. Use of such information may require a license from a third party under the patents or other intellectual property of the third party, or a license from TI under the patents or other intellectual property of TI.

Reproduction of information in TI data books or data sheets is permissible only if reproduction is without alteration and is accompanied by all associated warranties, conditions, limitations, and notices. Reproduction of this information with alteration is an unfair and deceptive business practice. TI is not responsible or liable for such altered documentation.

Resale of TI products or services with statements different from or beyond the parameters stated by TI for that product or service voids all express and any implied warranties for the associated TI product or service and is an unfair and deceptive business practice. TI is not responsible or liable for any such statements.

Following are URLs where you can obtain information on other Texas Instruments products and application solutions:

Products		Applications	
Amplifiers	amplifier.ti.com	Audio	www.ti.com/audio
Data Converters	dataconverter.ti.com	Automotive	www.ti.com/automotive
DSP	dsp.ti.com	Broadband	www.ti.com/broadband
Interface	interface.ti.com	Digital Control	www.ti.com/digitalcontrol
Logic	logic.ti.com	Military	www.ti.com/military
Power Mgmt	power.ti.com	Optical Networking	www.ti.com/opticalnetwork
Microcontrollers	microcontroller.ti.com	Security	www.ti.com/security
		Telephony	www.ti.com/telephony
		Video & Imaging	www.ti.com/video
		Wireless	www.ti.com/wireless

Mailing Address: Texas Instruments
Post Office Box 655303 Dallas, Texas 75265