

LM124, LM124A, LM224, LM224A, LM324, LM324A, LM2902, LM2902V, LM224K, LM224KA, LM324K, LM324KA, LM2902K, LM2902KV, LM2902KAV QUADRUPLE OPERATIONAL AMPLIFIERS

SLOS066T – SEPTEMBER 1975 – REVISED MARCH 2010

- **2-kV ESD Protection for:**
 - LM224K, LM224KA
 - LM324K, LM324KA
 - LM2902K, LM2902KV, LM2902KAV
- **Wide Supply Ranges**
 - Single Supply . . . 3 V to 32 V
(26 V for LM2902)
 - Dual Supplies . . . ± 1.5 V to ± 16 V
(± 13 V for LM2902)
- **Low Supply-Current Drain Independent of Supply Voltage . . . 0.8 mA Typ**
- **Common-Mode Input Voltage Range Includes Ground, Allowing Direct Sensing Near Ground**
- **Low Input Bias and Offset Parameters**
 - Input Offset Voltage . . . 3 mV Typ
A Versions . . . 2 mV Typ
 - Input Offset Current . . . 2 nA Typ
 - Input Bias Current . . . 20 nA Typ
A Versions . . . 15 nA Typ
- **Differential Input Voltage Range Equal to Maximum-Rated Supply Voltage . . . 32 V (26 V for LM2902)**
- **Open-Loop Differential Voltage Amplification . . . 100 V/mV Typ**
- **Internal Frequency Compensation**

LM124 . . . D, J, OR W PACKAGE
LM124A . . . J OR W PACKAGE
LM224, LM224A, LM224K, LM224KA . . . D OR N PACKAGE
LM324, LM324K . . . D, N, NS, OR PW PACKAGE
LM324A . . . D, DB, N, NS, OR PW PACKAGE
LM324KA . . . D, N, NS, OR PW PACKAGE
LM2902 . . . D, N, NS, OR PW PACKAGE
LM2902K . . . D, DB, N, NS, OR PW PACKAGE
LM2902KV, LM2902KAV . . . D OR PW PACKAGE
(TOP VIEW)

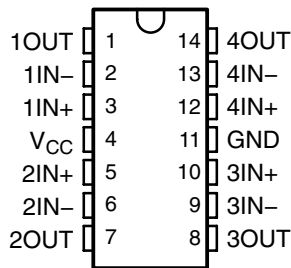

LM124, LM124A . . . FK PACKAGE
(TOP VIEW)

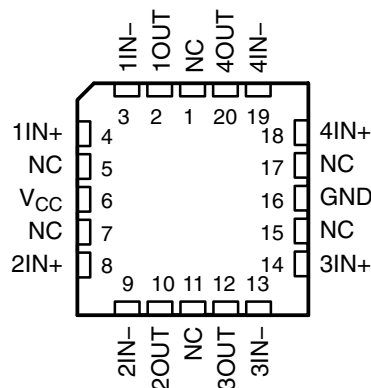

NC – No internal connection

description/ordering information

These devices consist of four independent high-gain frequency-compensated operational amplifiers that are designed specifically to operate from a single supply over a wide range of voltages. Operation from split supplies also is possible if the difference between the two supplies is 3 V to 32 V (3 V to 26 V for the LM2902), and V_{CC} is at least 1.5 V more positive than the input common-mode voltage. The low supply-current drain is independent of the magnitude of the supply voltage.

Applications include transducer amplifiers, dc amplification blocks, and all the conventional operational-amplifier circuits that now can be more easily implemented in single-supply-voltage systems. For example, the LM124 can be operated directly from the standard 5-V supply that is used in digital systems and provides the required interface electronics, without requiring additional ± 15 -V supplies.

**LM124, LM124A, LM224, LM224A, LM324, LM324A, LM2902, LM2902V,
LM224K, LM224KA, LM324K, LM324KA, LM2902K, LM2902KV, LM2902KAV
QUADRUPLE OPERATIONAL AMPLIFIERS**

SLOS066T – SEPTEMBER 1975 – REVISED MARCH 2010

ORDERING INFORMATION†

| T_A | V_{IOmax} AT 25°C | MAX TESTED V_{CC} | PACKAGE‡ | | ORDERABLE PART NUMBER | TOP-SIDE MARKING |
|---------------|------------------------|---------------------------|--------------|--------------|--------------------------|---------------------|
| 0°C to 70°C | 7 mV | 30 V | PDIP (N) | Tube of 25 | LM324N | LM324N |
| | | | | | LM324KN | LM324KN |
| | | | SOIC (D) | Tube of 50 | LM324D | LM324 |
| | | | | Reel of 2500 | LM324DR | |
| | | | | Reel of 2500 | LM324DRG3 | |
| | | | | Tube of 50 | LM324KD | LM324K |
| | | | | Reel of 2500 | LM324KDR | |
| | | | | SOP (NS) | Reel of 2000 | LM324NSR |
| | | | Tube of 50 | | LM324KNS | LM324K |
| | | | Reel of 2000 | | LM324KNSR | |
| | | | TSSOP (PW) | Tube of 90 | LM324PW | L324 |
| | | | | Reel of 2000 | LM324PWR | |
| | Tube of 90 | LM324KPW | | L324K | | |
| | Reel of 2000 | LM324KPWR | | | | |
| | 3 mV | 30 V | PDIP (N) | Tube of 25 | LM324AN | LM324AN |
| | | | | | LM324KAN | LM324KAN |
| | | | SOIC (D) | Tube of 50 | LM324AD | LM324A |
| | | | | Reel of 2500 | LM324ADR | |
| | | | | Tube of 50 | LM324KAD | LM324KA |
| | | | | Reel of 2500 | LM324KADR | |
| | | | SOP (NS) | Reel of 2000 | LM324ANSR | LM324A |
| | | | | Tube of 50 | LM324KANS | LM324KA |
| | | | | Reel of 2000 | LM324KANSR | |
| | | | SSOP (DB) | Reel of 2000 | LM324ADBR | LM324A |
| TSSOP (PW) | | | Tube of 90 | LM324APW | L324A | |
| | | | Reel of 2000 | LM324APWR | | |
| | Tube of 90 | LM324KAPW | L324KA | | | |
| | Reel of 2000 | LM324KAPWR | | | | |
| -25°C to 85°C | 5 mV | 30 V | PDIP (N) | Tube of 25 | LM224N | LM224N |
| | | | | | LM224KN | LM224KN |
| | | | SOIC (D) | Tube of 50 | LM224D | LM224 |
| | | | | Reel of 2500 | LM224DR | |
| | | | | Tube of 50 | LM224KD | LM224K |
| | | | | Reel of 2500 | LM224KDR | |
| | 3 mV | 30 V | PDIP (N) | Tube of 25 | LM224AN | LM224AN |
| | | | | | LM224KAN | LM224KAN |
| | | | SOIC (D) | Tube of 50 | LM224AD | LM224A |
| | | | | Reel of 2500 | LM224ADR | |
| | | | | Tube of 50 | LM224KAD | LM224KA |
| | | | | Reel of 2500 | LM224KADR | |

† For the most current package and ordering information, see the Package Option Addendum at the end of this document, or see the TI web site at www.ti.com.

‡ Package drawings, thermal data, and symbolization are available at www.ti.com/packaging.



LM124, LM124A, LM224, LM224A, LM324, LM324A, LM2902, LM2902V, LM224K, LM224KA, LM324K, LM324KA, LM2902K, LM2902KV, LM2902KAV QUADRUPLE OPERATIONAL AMPLIFIERS

SLOS066T – SEPTEMBER 1975 – REVISED MARCH 2010

ORDERING INFORMATION (CONTINUED)

| T_A | V_{IOmax} AT 25°C | MAX TESTED V_{CC} | PACKAGE† | ORDERABLE PART NUMBER | TOP-SIDE MARKING | | |
|----------------|------------------------|---------------------------|------------|--------------------------|---------------------|-------------|----------|
| -40°C to 125°C | 7 mV | 26 V | PDIP (N) | Tube of 25 | LM2902N | LM2902N | |
| | | | | Tube of 25 | LM2902KN | LM2902KN | |
| | | | SOIC (D) | Tube of 50 | LM2902D | LM2902 | |
| | | | | Reel of 2500 | LM2902DR | | |
| | | | | Tube of 50 | LM2902KD | LM2902K | |
| | | | | Reel of 2500 | LM2902KDR | | |
| | | | SOP (NS) | Reel of 2000 | LM2902NSR | LM2902 | |
| | | | | Tube of 50 | LM2902KNS | LM2902K | |
| | | | | Reel of 2000 | LM2902KNSR | | |
| | | | SSOP (DB) | Tube of 80 | LM2902KDB | L2902K | |
| | | | | Reel of 2000 | LM2902KDBR | | |
| | | | TSSOP (PW) | Tube of 90 | LM2902PW | L2902 | |
| | Reel of 2000 | LM2902PWR | | | | | |
| | Tube of 90 | LM2902KPW | | L2902K | | | |
| | Reel of 2000 | LM2902KPWR | | | | | |
| | 2 mV | 32 V | | SOIC (D) | Reel of 2500 | LM2902KVQDR | L2902KV |
| TSSOP (PW) | | | | Reel of 2000 | LM2902KVQPWR | L2902KV | |
| SOIC (D) | | | | Reel of 2500 | LM2902KAVQDR | L2902KA | |
| TSSOP (PW) | | | | Reel of 2000 | LM2902KAVQPWR | L2902KA | |
| -55°C to 125°C | 5 mV | 30 V | CDIP (J) | Tube of 25 | LM124J | LM124J | |
| | | | CFP (W) | Tube of 25 | LM124W | LM124W | |
| | | | LCCC (FK) | Tube of 55 | LM124FK | LM124FK | |
| | | | SOIC (D) | Tube of 50 | LM124D | LM124 | |
| | | | | Reel of 2500 | LM124DR | | |
| | 2 mV | 30 V | | CDIP (J) | Tube of 25 | LM124AJ | LM124AJ |
| | | | | CFP (W) | Tube of 25 | LM124AW | LM124AW |
| | | | | LCCC (FK) | Tube of 55 | LM124AFK | LM124AFK |
| | | | | | | | |

† Package drawings, standard packing quantities, thermal data, symbolization, and PCB design guidelines are available at www.ti.com/sc/package.

symbol (each amplifier)

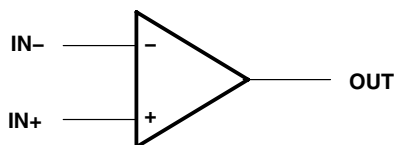

LM124, LM124A, LM224, LM224A, LM324, LM324A, LM2902, LM2902V, LM224K, LM224KA, LM324K, LM324KA, LM2902K, LM2902KV, LM2902KAV QUADRUPLE OPERATIONAL AMPLIFIERS

SLOS066T – SEPTEMBER 1975 – REVISED MARCH 2010

schematic (each amplifier)

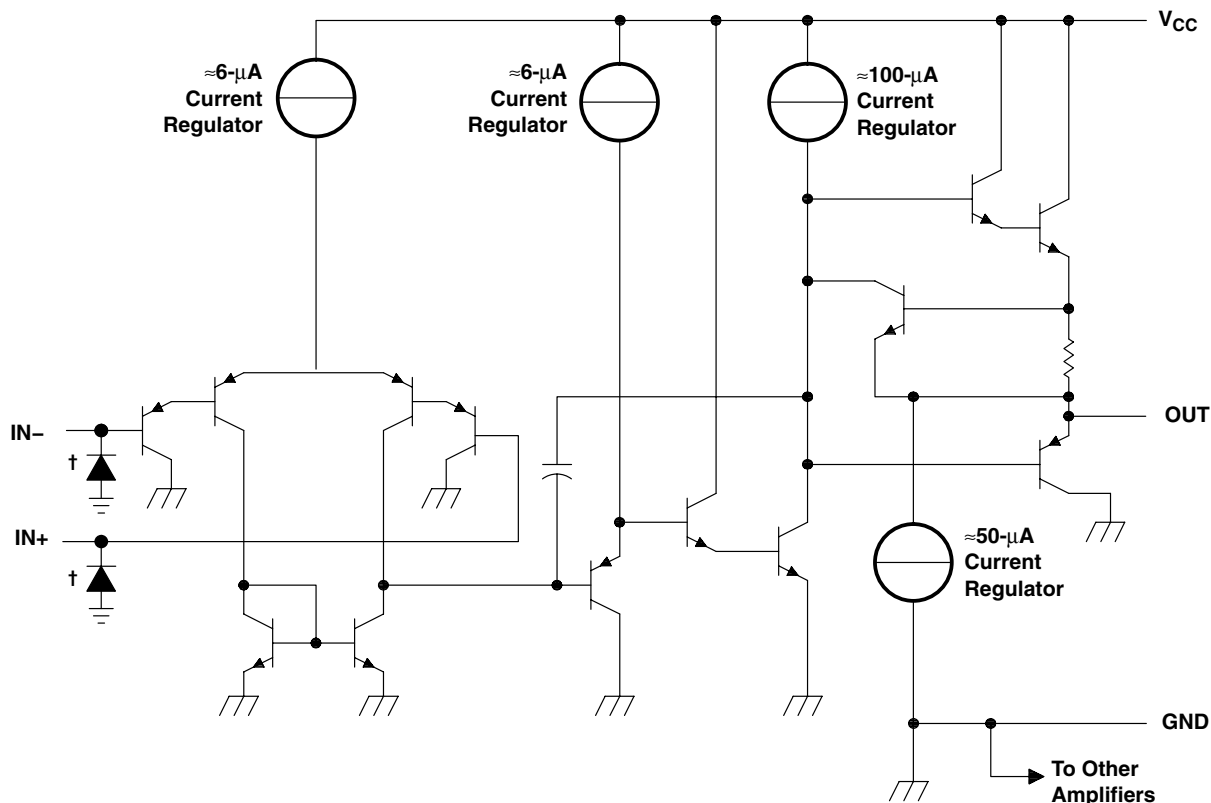

| COMPONENT COUNT (total device) | |
|-----------------------------------|----|
| Epi-FET | 1 |
| Transistors | 95 |
| Diodes | 4 |
| Resistors | 11 |
| Capacitors | 4 |

† ESD protection cells - available on LM324K and LM324KA only

LM124, LM124A, LM224, LM224A, LM324, LM324A, LM2902, LM2902V, LM224K, LM224KA, LM324K, LM324KA, LM2902K, LM2902KV, LM2902KAV QUADRUPLE OPERATIONAL AMPLIFIERS

SLOS066T – SEPTEMBER 1975 – REVISED MARCH 2010

absolute maximum ratings over operating free-air temperature range (unless otherwise noted)†

| | | LM2902 | ALL OTHER DEVICES | UNIT |
|---|----------------|------------|-------------------|--------------------|
| Supply voltage, V_{CC} (see Note 1) | | ±13 or 26 | ±16 or 32 | V |
| Differential input voltage, V_{ID} (see Note 2) | | ±26 | ±32 | V |
| Input voltage, V_I (either input) | | -0.3 to 26 | -0.3 to 32 | V |
| Duration of output short circuit (one amplifier) to ground at (or below) $T_A = 25^\circ\text{C}$, $V_{CC} \leq 15\text{ V}$ (see Note 3) | | Unlimited | Unlimited | |
| Package thermal impedance, θ_{JA} (see Notes 4 and 5) | D package | 86 | 86 | $^\circ\text{C/W}$ |
| | DB package | 96 | 96 | |
| | N package | 80 | 80 | |
| | NS package | 76 | 76 | |
| | PW package | 113 | 113 | |
| Package thermal impedance, θ_{JC} (see Notes 6 and 7) | FK package | | 5.61 | $^\circ\text{C/W}$ |
| | J package | | 15.05 | |
| | W package | | 14.65 | |
| Operating virtual junction temperature, T_J | | 150 | 150 | $^\circ\text{C}$ |
| Case temperature for 60 seconds | FK package | | 260 | $^\circ\text{C}$ |
| Lead temperature 1,6 mm (1/16 inch) from case for 60 seconds | J or W package | 300 | 300 | $^\circ\text{C}$ |
| Storage temperature range, T_{stg} | | -65 to 150 | -65 to 150 | $^\circ\text{C}$ |

† Stresses beyond those listed under “absolute maximum ratings” may cause permanent damage to the device. These are stress ratings only, and functional operation of the device at these or any other conditions beyond those indicated under “recommended operating conditions” is not implied. Exposure to absolute-maximum-rated conditions for extended periods may affect device reliability.

- NOTES:
- All voltage values (except differential voltages and V_{CC} specified for the measurement of I_{OS}) are with respect to the network GND.
 - Differential voltages are at $IN+$, with respect to $IN-$.
 - Short circuits from outputs to V_{CC} can cause excessive heating and eventual destruction.
 - Maximum power dissipation is a function of $T_J(\text{max})$, θ_{JA} , and T_A . The maximum allowable power dissipation at any allowable ambient temperature is $P_D = (T_J(\text{max}) - T_A)/\theta_{JA}$. Operating at the absolute maximum T_J of 150°C can affect reliability.
 - The package thermal impedance is calculated in accordance with JESD 51-7.
 - Maximum power dissipation is a function of $T_J(\text{max})$, θ_{JC} , and T_C . The maximum allowable power dissipation at any allowable case temperature is $P_D = (T_J(\text{max}) - T_C)/\theta_{JC}$. Operating at the absolute maximum T_J of 150°C can affect reliability.
 - The package thermal impedance is calculated in accordance with MIL-STD-883.

ESD protection

| TEST CONDITIONS | | TYP | UNIT |
|------------------|--|-----|------|
| Human-Body Model | LM224K, LM224KA, LM324K, LM324KA, LM2902K, LM2902KV, LM2902KAV | ±2 | kV |



LM124, LM124A, LM224, LM224A, LM324, LM324A, LM2902, LM2902V, LM224K, LM224KA, LM324K, LM324KA, LM2902K, LM2902KV, LM2902KAV QUADRUPLE OPERATIONAL AMPLIFIERS

SLOS066T – SEPTEMBER 1975 – REVISED MARCH 2010

electrical characteristics at specified free-air temperature, $V_{CC} = 5\text{ V}$ (unless otherwise noted)

| PARAMETER | TEST CONDITIONS† | T_A ‡ | LM124 LM224 | | | LM324 LM324K | | | UNIT | | |
|--|---|------------------------------|----------------|---------------------|----------|---------------------|----------------|----------|---------------|-----|----|
| | | | MIN | TYP§ | MAX | MIN | TYP§ | MAX | | | |
| V_{IO} Input offset voltage | $V_{CC} = 5\text{ V to MAX}$, $V_{IC} = V_{ICRmin}$, $V_O = 1.4\text{ V}$ | 25°C | | 3 | 5 | | 3 | 7 | mV | | |
| | | Full range | | | 7 | | | 9 | | | |
| I_{IO} Input offset current | $V_O = 1.4\text{ V}$ | 25°C | | 2 | 30 | | 2 | 50 | nA | | |
| | | Full range | | | 100 | | | 150 | | | |
| I_{IB} Input bias current | $V_O = 1.4\text{ V}$ | 25°C | | -20 | -150 | | -20 | -250 | nA | | |
| | | Full range | | | -300 | | | -500 | | | |
| V_{ICR} Common-mode input voltage range | $V_{CC} = 5\text{ V to MAX}$ | 25°C | | 0 to $V_{CC} - 1.5$ | | 0 to $V_{CC} - 1.5$ | | | V | | |
| | | Full range | | 0 to $V_{CC} - 2$ | | 0 to $V_{CC} - 2$ | | | | | |
| V_{OH} High-level output voltage | $R_L = 2\text{ k}\Omega$ | 25°C | | $V_{CC} - 1.5$ | | | $V_{CC} - 1.5$ | | | V | |
| | $R_L = 10\text{ k}\Omega$ | 25°C | | | | | | | | | |
| | $V_{CC} = \text{MAX}$ | $R_L = 2\text{ k}\Omega$ | Full range | | 26 | | 26 | | | | |
| | | $R_L \geq 10\text{ k}\Omega$ | Full range | | 27 | 28 | 27 | 28 | | | |
| V_{OL} Low-level output voltage | $R_L \leq 10\text{ k}\Omega$ | Full range | | 5 | 20 | | 5 | 20 | mV | | |
| A_{VD} Large-signal differential voltage amplification | $V_{CC} = 15\text{ V}$, $V_O = 1\text{ V to }11\text{ V}$, $R_L \geq 2\text{ k}\Omega$ | 25°C | | 50 | 100 | | 25 | 100 | V/mV | | |
| | | Full range | | 25 | | | 15 | | | | |
| CMRR Common-mode rejection ratio | $V_{IC} = V_{ICRmin}$ | 25°C | | 70 | 80 | | 65 | 80 | dB | | |
| k_{SVR} Supply-voltage rejection ratio ($\Delta V_{CC}/\Delta V_{IO}$) | | 25°C | | 65 | 100 | | 65 | 100 | dB | | |
| V_{O1}/V_{O2} Crosstalk attenuation | $f = 1\text{ kHz to }20\text{ kHz}$ | 25°C | | 120 | | | 120 | | | dB | |
| I_O Output current | $V_{CC} = 15\text{ V}$, $V_{ID} = 1\text{ V}$, $V_O = 0$ | Source | 25°C | | -20 | -30 | -60 | -20 | -30 | -60 | mA |
| | | | Full range | | | -10 | | -10 | | | |
| | $V_{CC} = 15\text{ V}$, $V_{ID} = -1\text{ V}$, $V_O = 15\text{ V}$ | Sink | 25°C | | 10 | 20 | | 10 | 20 | | |
| | | | Full range | | 5 | | 5 | | | | |
| | $V_{ID} = -1\text{ V}$, $V_O = 200\text{ mV}$ | 25°C | | 12 | 30 | | 12 | 30 | μA | | |
| I_{OS} Short-circuit output current | V_{CC} at 5 V, GND at -5 V | $V_O = 0$, | 25°C | | ± 40 | ± 60 | | ± 40 | ± 60 | mA | |
| I_{CC} Supply current (four amplifiers) | $V_O = 2.5\text{ V}$, No load | Full range | | 0.7 | 1.2 | | 0.7 | 1.2 | mA | | |
| | $V_{CC} = \text{MAX}$, $V_O = 0.5 V_{CC}$, No load | Full range | | 1.4 | 3 | | 1.4 | 3 | | | |

† All characteristics are measured under open-loop conditions, with zero common-mode input voltage, unless otherwise specified. MAX V_{CC} for testing purposes is 26 V for LM2902 and 30 V for the others.

‡ Full range is -55°C to 125°C for LM124, -25°C to 85°C for LM224, and 0°C to 70°C for LM324.

§ All typical values are at $T_A = 25^\circ\text{C}$.



LM124, LM124A, LM224, LM224A, LM324, LM324A, LM2902, LM2902V, LM224K, LM224KA, LM324K, LM324KA, LM2902K, LM2902KV, LM2902KAV QUADRUPLE OPERATIONAL AMPLIFIERS

SLOS066T – SEPTEMBER 1975 – REVISED MARCH 2010

electrical characteristics at specified free-air temperature, $V_{CC} = 5\text{ V}$ (unless otherwise noted)

| PARAMETER | TEST CONDITIONS† | | T_A ‡ | LM2902 | | | LM2902V | | | UNIT | |
|--|---|------------------------------|-------------|---------------------|-----------------|---------------------|-----------------|------|-----|------------------------------|----|
| | | | | MIN | TYP§ | MAX | MIN | TYP§ | MAX | | |
| V_{IO} Input offset voltage | $V_{CC} = 5\text{ V}$ to MAX, $V_{IC} = V_{ICRmin}$, $V_O = 1.4\text{ V}$ | Non-A-suffix devices | 25°C | 3 7 | | 3 7 | | | | mV | |
| | | | Full range | | | 10 | | 10 | | | |
| | | A-suffix devices | 25°C | | | 1 2 | | | | | |
| | | | Full range | | | | | 4 | | | |
| $\Delta V_{IO}/\Delta T$ Input offset voltage temperature drift | $R_S = 0\ \Omega$ | | Full range | | | 7 | | | | $\mu\text{V}/^\circ\text{C}$ | |
| I_{IO} Input offset current | $V_O = 1.4\text{ V}$ | | 25°C | 2 50 | | 2 50 | | | | nA | |
| | | | Full range | | | 300 | | 150 | | | |
| $\Delta I_{IO}/\Delta T$ Input offset current temperature drift | | | Full range | | | 10 | | | | $\text{pA}/^\circ\text{C}$ | |
| I_{IB} Input bias current | $V_O = 1.4\text{ V}$ | | 25°C | -20 -250 | | -20 -250 | | | | nA | |
| | | | Full range | | | -500 | | -500 | | | |
| V_{ICR} Common-mode input voltage range | $V_{CC} = 5\text{ V}$ to MAX | | 25°C | 0 to $V_{CC} - 1.5$ | | 0 to $V_{CC} - 1.5$ | | | | V | |
| | | | Full range | 0 to $V_{CC} - 2$ | | 0 to $V_{CC} - 2$ | | | | | |
| V_{OH} High-level output voltage | $R_L = 2\text{ k}\Omega$ | | 25°C | | | | | | | V | |
| | | | 25°C | $V_{CC} - 1.5$ | | $V_{CC} - 1.5$ | | | | | |
| | $V_{CC} = \text{MAX}$ | $R_L = 2\text{ k}\Omega$ | Full range | 22 26 | | 26 | | | | | |
| | | $R_L \geq 10\text{ k}\Omega$ | Full range | 23 24 | | 27 | | | | | |
| V_{OL} Low-level output voltage | $R_L \leq 10\text{ k}\Omega$ | | Full range | 5 20 | | 5 20 | | | | mV | |
| A_{VD} Large-signal differential voltage amplification | $V_{CC} = 15\text{ V}$, $V_O = 1\text{ V}$ to 11 V , $R_L \geq 2\text{ k}\Omega$ | | 25°C | 25 100 | | 25 100 | | | | V/mV | |
| | | | Full range | 15 | | 15 | | | | | |
| CMRR Common-mode rejection ratio | $V_{IC} = V_{ICRmin}$ | | 25°C | 50 80 | | 60 80 | | | | dB | |
| k_{SVR} Supply-voltage rejection ratio ($\Delta V_{CC}/\Delta V_{IO}$) | | | 25°C | 50 100 | | 60 100 | | | | dB | |
| V_{O1}/V_{O2} Crosstalk attenuation | $f = 1\text{ kHz}$ to 20 kHz | | 25°C | 120 | | 120 | | | | dB | |
| I_O Output current | $V_{CC} = 15\text{ V}$, $V_{ID} = 1\text{ V}$, $V_O = 0$ | Source | 25°C | -20 -30 -60 | | -20 -30 -60 | | | | mA | |
| | | | Full range | -10 | | -10 | | | | | |
| | $V_{CC} = 15\text{ V}$, $V_{ID} = -1\text{ V}$, $V_O = 15\text{ V}$ | Sink | 25°C | 10 20 | | 10 20 | | | | | |
| | | | Full range | 5 | | 5 | | | | | |
| $V_{ID} = -1\text{ V}$, $V_O = 200\text{ mV}$ | | | 25°C | 30 | | 12 40 | | | | μA | |
| I_{OS} Short-circuit output current | V_{CC} at 5 V , GND at -5 V | | $V_O = 0$, | 25°C | $\pm 40 \pm 60$ | | $\pm 40 \pm 60$ | | | | mA |
| I_{CC} Supply current (four amplifiers) | $V_O = 2.5\text{ V}$, No load | | Full range | 0.7 1.2 | | 0.7 1.2 | | | | mA | |
| | $V_{CC} = \text{MAX}$, $V_O = 0.5 V_{CC}$, No load | | Full range | 1.4 3 | | 1.4 3 | | | | | |

† All characteristics are measured under open-loop conditions, with zero common-mode input voltage, unless otherwise specified. MAX V_{CC} for testing purposes is 26 V for LM2902 and 32 V for LM2902V.

‡ Full range is -40°C to 125°C for LM2902.

§ All typical values are at $T_A = 25^\circ\text{C}$.



electrical characteristics at specified free-air temperature, $V_{CC} = 5\text{ V}$ (unless otherwise noted)

| PARAMETER | TEST CONDITIONS† | T_A ‡ | LM124A | | | LM224A | | | LM324A, LM324KA | | | UNIT | |
|--|---|----------------------|------------------------------|----------|----------|---------------------|----------|----------|---------------------|---------------|----------|------|----|
| | | | MIN | TYP§ | MAX | MIN | TYP§ | MAX | MIN | TYP§ | MAX | | |
| V_{IO} Input offset voltage | $V_{CC} = 5\text{ V to }30\text{ V},$ $V_{IC} = V_{ICRmin}, V_O = 1.4\text{ V}$ | 25°C | | | 2 | | 2 | 3 | | 2 | 3 | mV | |
| | | Full range | | | 4 | | | 4 | | | 5 | | |
| I_{IO} Input offset current | $V_O = 1.4\text{ V}$ | 25°C | | | 10 | | 2 | 15 | | 2 | 30 | nA | |
| | | Full range | | | 30 | | | 30 | | | 75 | | |
| I_{IB} Input bias current | $V_O = 1.4\text{ V}$ | 25°C | | | -50 | | -15 | -80 | | -15 | -100 | nA | |
| | | Full range | | | -100 | | | -100 | | | -200 | | |
| V_{ICR} Common-mode input voltage range | $V_{CC} = 30\text{ V}$ | 25°C | 0 to $V_{CC} - 1.5$ | | | 0 to $V_{CC} - 1.5$ | | | 0 to $V_{CC} - 1.5$ | | | V | |
| | | Full range | 0 to $V_{CC} - 2$ | | | 0 to $V_{CC} - 2$ | | | 0 to $V_{CC} - 2$ | | | | |
| V_{OH} High-level output voltage | $R_L = 2\text{ k}\Omega$ $V_{CC} = 30\text{ V}$ | 25°C | $V_{CC} - 1.5$ | | | $V_{CC} - 1.5$ | | | $V_{CC} - 1.5$ | | | V | |
| | | Full range | $R_L = 2\text{ k}\Omega$ | | | 26 | | | 26 | | | | |
| | | | $R_L \geq 10\text{ k}\Omega$ | | | 27 | | | 27 28 | | | | |
| V_{OL} Low-level output voltage | $R_L \leq 10\text{ k}\Omega$ | Full range | | | 20 | | 5 | 20 | | 5 | 20 | mV | |
| A_{VD} Large-signal differential voltage amplification | $V_{CC} = 15\text{ V}, V_O = 1\text{ V to }11\text{ V},$ $R_L \geq 2\text{ k}\Omega$ | 25°C | 50 | 100 | | 50 | 100 | | 25 | 100 | V/mV | | |
| | | Full range | 25 | | | 25 | | | 15 | | | | |
| CMRR Common-mode rejection ratio | $V_{IC} = V_{ICRmin}$ | 25°C | 70 | | | 70 | 80 | | 65 | 80 | dB | | |
| k_{SVR} Supply-voltage rejection ratio ($\Delta V_{CC}/\Delta V_{IO}$) | | 25°C | 65 | | | 65 | 100 | | 65 | 100 | dB | | |
| V_{O1}/V_{O2} Crosstalk attenuation | $f = 1\text{ kHz to }20\text{ kHz}$ | 25°C | | 120 | | | 120 | | | 120 | dB | | |
| I_O Output current | $V_{CC} = 15\text{ V},$ $V_{ID} = 1\text{ V},$ $V_O = 0$ | Source | 25°C | -20 | | | -20 | -30 | -60 | -20 | -30 | -60 | mA |
| | | Full range | -10 | | | -10 | | | -10 | | | | |
| | Sink | 25°C | 10 | | | 10 | 20 | | 10 | 20 | | | |
| | | Full range | 5 | | | 5 | | | 5 | | | | |
| $V_{ID} = -1\text{ V},$ $V_O = 200\text{ mV}$ | 25°C | 12 | | | 12 | 30 | | 12 | 30 | μA | | | |
| I_{OS} Short-circuit output current | V_{CC} at 5 V, $V_O = 0$ | GND at -5 V, 25°C | | ± 40 | ± 60 | | ± 40 | ± 60 | | ± 40 | ± 60 | mA | |
| I_{CC} Supply current (four amplifiers) | $V_O = 2.5\text{ V},$ No load | Full range | | 0.7 | 1.2 | | 0.7 | 1.2 | | 0.7 | 1.2 | mA | |
| | $V_{CC} = 30\text{ V},$ No load | Full range | | 1.4 | 3 | | 1.4 | 3 | | 1.4 | 3 | | |

† All characteristics are measured under open-loop conditions, with zero common-mode input voltage, unless otherwise specified.

‡ Full range is -55°C to 125°C for LM124A, -25°C to 85°C for LM224A, and 0°C to 70°C for LM324A.

§ All typical values are at $T_A = 25^\circ\text{C}$.

**LM124, LM124A, LM224, LM224A, LM324, LM324A, LM2902, LM2902V,
LM224K, LM224KA, LM324K, LM324KA, LM2902K, LM2902KV, LM2902KAV
QUADRUPLE OPERATIONAL AMPLIFIERS**

SLOS066T – SEPTEMBER 1975 – REVISED MARCH 2010

operating conditions, $V_{CC} = \pm 15\text{ V}$, $T_A = 25^\circ\text{C}$

| PARAMETER | | TEST CONDITIONS | TYP | UNIT |
|-----------|--------------------------------|--|-----|------------------------------|
| SR | Slew rate at unity gain | $R_L = 1\text{ M}\Omega$, $C_L = 30\text{ pF}$, $V_I = \pm 10\text{ V}$ (see Figure 1) | 0.5 | $\text{V}/\mu\text{s}$ |
| B_1 | Unity-gain bandwidth | $R_L = 1\text{ M}\Omega$, $C_L = 20\text{ pF}$ (see Figure 1) | 1.2 | MHz |
| V_n | Equivalent input noise voltage | $R_S = 100\ \Omega$, $V_I = 0\text{ V}$, $f = 1\text{ kHz}$ (see Figure 2) | 35 | $\text{nV}/\sqrt{\text{Hz}}$ |

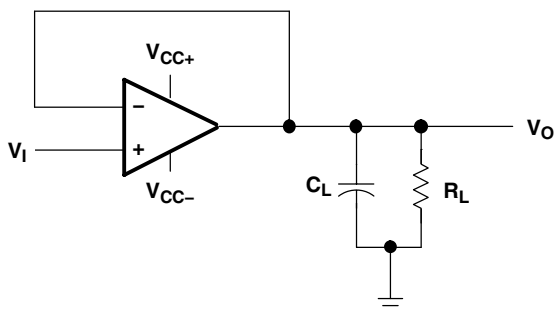

Figure 1. Unity-Gain Amplifier

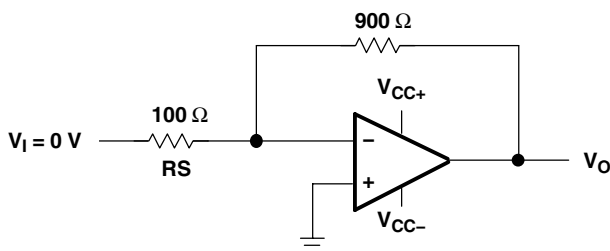

Figure 2. Noise-Test Circuit

PACKAGING INFORMATION

| Orderable Device | Status ⁽¹⁾ | Package Type | Package Drawing | Pins | Package Qty | Eco Plan ⁽²⁾ | Lead/Ball Finish | MSL Peak Temp ⁽³⁾ |
|------------------|-----------------------|--------------|-----------------|------|-------------|-------------------------|------------------|------------------------------|
| 5962-7704301VCA | ACTIVE | CDIP | J | 14 | 1 | TBD | A42 | N / A for Pkg Type |
| 77043012A | ACTIVE | LCCC | FK | 20 | 1 | TBD | POST-PLATE | N / A for Pkg Type |
| 7704301CA | ACTIVE | CDIP | J | 14 | 1 | TBD | A42 | N / A for Pkg Type |
| 7704301DA | ACTIVE | CFP | W | 14 | 1 | TBD | A42 | N / A for Pkg Type |
| 77043022A | ACTIVE | LCCC | FK | 20 | 1 | TBD | POST-PLATE | N / A for Pkg Type |
| 7704302CA | ACTIVE | CDIP | J | 14 | 1 | TBD | A42 | N / A for Pkg Type |
| 7704302DA | ACTIVE | CFP | W | 14 | 1 | TBD | A42 | N / A for Pkg Type |
| JM38510/11005BCA | ACTIVE | CDIP | J | 14 | 1 | TBD | A42 | N / A for Pkg Type |
| LM124ADR | OBSOLETE | SOIC | D | 14 | | TBD | Call TI | Call TI |
| LM124AFKB | ACTIVE | LCCC | FK | 20 | 1 | TBD | POST-PLATE | N / A for Pkg Type |
| LM124AJ | ACTIVE | CDIP | J | 14 | 1 | TBD | A42 | N / A for Pkg Type |
| LM124AJB | ACTIVE | CDIP | J | 14 | 1 | TBD | A42 | N / A for Pkg Type |
| LM124AWB | ACTIVE | CFP | W | 14 | 1 | TBD | A42 | N / A for Pkg Type |
| LM124D | ACTIVE | SOIC | D | 14 | 50 | TBD | CU NIPDAU | Level-3-245C-168 HR |
| LM124DG4 | ACTIVE | SOIC | D | 14 | 50 | Green (RoHS & no Sb/Br) | CU NIPDAU | Level-1-260C-UNLIM |
| LM124DR | ACTIVE | SOIC | D | 14 | 2500 | TBD | CU NIPDAU | Level-3-245C-168 HR |
| LM124DRG4 | ACTIVE | SOIC | D | 14 | 2500 | Green (RoHS & no Sb/Br) | CU NIPDAU | Level-1-260C-UNLIM |
| LM124FKB | ACTIVE | LCCC | FK | 20 | 1 | TBD | POST-PLATE | N / A for Pkg Type |
| LM124J | ACTIVE | CDIP | J | 14 | 1 | TBD | A42 | N / A for Pkg Type |
| LM124JB | ACTIVE | CDIP | J | 14 | 1 | TBD | A42 | N / A for Pkg Type |
| LM124N | OBSOLETE | PDIP | N | 14 | | TBD | Call TI | Call TI |
| LM124W | ACTIVE | CFP | W | 14 | 1 | TBD | A42 | N / A for Pkg Type |
| LM124WB | ACTIVE | CFP | W | 14 | 1 | TBD | A42 | N / A for Pkg Type |
| LM224AD | ACTIVE | SOIC | D | 14 | 50 | Green (RoHS & no Sb/Br) | CU NIPDAU | Level-1-260C-UNLIM |
| LM224ADE4 | ACTIVE | SOIC | D | 14 | 50 | Green (RoHS & no Sb/Br) | CU NIPDAU | Level-1-260C-UNLIM |
| LM224ADG4 | ACTIVE | SOIC | D | 14 | 50 | Green (RoHS & no Sb/Br) | CU NIPDAU | Level-1-260C-UNLIM |
| LM224ADR | ACTIVE | SOIC | D | 14 | 2500 | Green (RoHS & no Sb/Br) | CU NIPDAU | Level-1-260C-UNLIM |
| LM224ADRE4 | ACTIVE | SOIC | D | 14 | 2500 | Green (RoHS & no Sb/Br) | CU NIPDAU | Level-1-260C-UNLIM |
| LM224ADRG4 | ACTIVE | SOIC | D | 14 | 2500 | Green (RoHS & no Sb/Br) | CU NIPDAU | Level-1-260C-UNLIM |
| LM224AN | ACTIVE | PDIP | N | 14 | 25 | Pb-Free (RoHS) | CU NIPDAU | N / A for Pkg Type |
| LM224ANE4 | ACTIVE | PDIP | N | 14 | 25 | Pb-Free (RoHS) | CU NIPDAU | N / A for Pkg Type |
| LM224D | ACTIVE | SOIC | D | 14 | 50 | Green (RoHS & no Sb/Br) | CU NIPDAU | Level-1-260C-UNLIM |
| LM224DE4 | ACTIVE | SOIC | D | 14 | 50 | Green (RoHS & no Sb/Br) | CU NIPDAU | Level-1-260C-UNLIM |
| LM224DG4 | ACTIVE | SOIC | D | 14 | 50 | Green (RoHS & no Sb/Br) | CU NIPDAU | Level-1-260C-UNLIM |

| Orderable Device | Status ⁽¹⁾ | Package Type | Package Drawing | Pins | Package Qty | Eco Plan ⁽²⁾ | Lead/Ball Finish | MSL Peak Temp ⁽³⁾ |
|------------------|-----------------------|--------------|-----------------|------|-------------|-------------------------|------------------|------------------------------|
| | | | | | | no Sb/Br) | | |
| LM224DR | ACTIVE | SOIC | D | 14 | 2500 | Green (RoHS & no Sb/Br) | CU NIPDAU | Level-1-260C-UNLIM |
| LM224DRE4 | ACTIVE | SOIC | D | 14 | 2500 | Green (RoHS & no Sb/Br) | CU NIPDAU | Level-1-260C-UNLIM |
| LM224DRG4 | ACTIVE | SOIC | D | 14 | 2500 | Green (RoHS & no Sb/Br) | CU NIPDAU | Level-1-260C-UNLIM |
| LM224KAD | ACTIVE | SOIC | D | 14 | 50 | Green (RoHS & no Sb/Br) | CU NIPDAU | Level-1-260C-UNLIM |
| LM224KADE4 | ACTIVE | SOIC | D | 14 | 50 | Green (RoHS & no Sb/Br) | CU NIPDAU | Level-1-260C-UNLIM |
| LM224KADG4 | ACTIVE | SOIC | D | 14 | 50 | Green (RoHS & no Sb/Br) | CU NIPDAU | Level-1-260C-UNLIM |
| LM224KADR | ACTIVE | SOIC | D | 14 | 2500 | Green (RoHS & no Sb/Br) | CU NIPDAU | Level-1-260C-UNLIM |
| LM224KADRE4 | ACTIVE | SOIC | D | 14 | 2500 | Green (RoHS & no Sb/Br) | CU NIPDAU | Level-1-260C-UNLIM |
| LM224KADRG4 | ACTIVE | SOIC | D | 14 | 2500 | Green (RoHS & no Sb/Br) | CU NIPDAU | Level-1-260C-UNLIM |
| LM224KAN | ACTIVE | PDIP | N | 14 | 25 | Pb-Free (RoHS) | CU NIPDAU | N / A for Pkg Type |
| LM224KANE4 | ACTIVE | PDIP | N | 14 | 25 | Pb-Free (RoHS) | CU NIPDAU | N / A for Pkg Type |
| LM224KD | ACTIVE | SOIC | D | 14 | 50 | Green (RoHS & no Sb/Br) | CU NIPDAU | Level-1-260C-UNLIM |
| LM224KDE4 | ACTIVE | SOIC | D | 14 | 50 | Green (RoHS & no Sb/Br) | CU NIPDAU | Level-1-260C-UNLIM |
| LM224KDG4 | ACTIVE | SOIC | D | 14 | 50 | Green (RoHS & no Sb/Br) | CU NIPDAU | Level-1-260C-UNLIM |
| LM224KDR | ACTIVE | SOIC | D | 14 | 2500 | Green (RoHS & no Sb/Br) | CU NIPDAU | Level-1-260C-UNLIM |
| LM224KDRE4 | ACTIVE | SOIC | D | 14 | 2500 | Green (RoHS & no Sb/Br) | CU NIPDAU | Level-1-260C-UNLIM |
| LM224KDRG4 | ACTIVE | SOIC | D | 14 | 2500 | Green (RoHS & no Sb/Br) | CU NIPDAU | Level-1-260C-UNLIM |
| LM224KN | ACTIVE | PDIP | N | 14 | 25 | Pb-Free (RoHS) | CU NIPDAU | N / A for Pkg Type |
| LM224KNE4 | ACTIVE | PDIP | N | 14 | 25 | Pb-Free (RoHS) | CU NIPDAU | N / A for Pkg Type |
| LM224N | ACTIVE | PDIP | N | 14 | 25 | Pb-Free (RoHS) | CU NIPDAU | N / A for Pkg Type |
| LM224NE4 | ACTIVE | PDIP | N | 14 | 25 | Pb-Free (RoHS) | CU NIPDAU | N / A for Pkg Type |
| LM2902D | ACTIVE | SOIC | D | 14 | 50 | Green (RoHS & no Sb/Br) | CU NIPDAU | Level-1-260C-UNLIM |
| LM2902DE4 | ACTIVE | SOIC | D | 14 | 50 | Green (RoHS & no Sb/Br) | CU NIPDAU | Level-1-260C-UNLIM |
| LM2902DG4 | ACTIVE | SOIC | D | 14 | 50 | Green (RoHS & no Sb/Br) | CU NIPDAU | Level-1-260C-UNLIM |
| LM2902DR | ACTIVE | SOIC | D | 14 | 2500 | Green (RoHS & no Sb/Br) | CU NIPDAU | Level-1-260C-UNLIM |

| Orderable Device | Status ⁽¹⁾ | Package Type | Package Drawing | Pins | Package Qty | Eco Plan ⁽²⁾ | Lead/Ball Finish | MSL Peak Temp ⁽³⁾ |
|------------------|-----------------------|--------------|-----------------|------|-------------|-------------------------|------------------|------------------------------|
| LM2902DRE4 | ACTIVE | SOIC | D | 14 | 2500 | Green (RoHS & no Sb/Br) | CU NIPDAU | Level-1-260C-UNLIM |
| LM2902DRG4 | ACTIVE | SOIC | D | 14 | 2500 | Green (RoHS & no Sb/Br) | CU NIPDAU | Level-1-260C-UNLIM |
| LM2902KAVQDR | ACTIVE | SOIC | D | 14 | 2500 | Green (RoHS & no Sb/Br) | CU NIPDAU | Level-1-260C-UNLIM |
| LM2902KAVQDRG4 | ACTIVE | SOIC | D | 14 | 2500 | Green (RoHS & no Sb/Br) | CU NIPDAU | Level-1-260C-UNLIM |
| LM2902KAVQPWR | ACTIVE | TSSOP | PW | 14 | 2000 | TBD | CU NIPDAU | Level-1-250C-UNLIM |
| LM2902KAVQPWRG4 | ACTIVE | TSSOP | PW | 14 | 2000 | Green (RoHS & no Sb/Br) | CU NIPDAU | Level-1-260C-UNLIM |
| LM2902KD | ACTIVE | SOIC | D | 14 | 50 | Green (RoHS & no Sb/Br) | CU NIPDAU | Level-1-260C-UNLIM |
| LM2902KDB | ACTIVE | SSOP | DB | 14 | 80 | Green (RoHS & no Sb/Br) | CU NIPDAU | Level-1-260C-UNLIM |
| LM2902KDBE4 | ACTIVE | SSOP | DB | 14 | 80 | Green (RoHS & no Sb/Br) | CU NIPDAU | Level-1-260C-UNLIM |
| LM2902KDBG4 | ACTIVE | SSOP | DB | 14 | 80 | Green (RoHS & no Sb/Br) | CU NIPDAU | Level-1-260C-UNLIM |
| LM2902KDBR | ACTIVE | SSOP | DB | 14 | 2000 | Green (RoHS & no Sb/Br) | CU NIPDAU | Level-1-260C-UNLIM |
| LM2902KDBRE4 | ACTIVE | SSOP | DB | 14 | 2000 | Green (RoHS & no Sb/Br) | CU NIPDAU | Level-1-260C-UNLIM |
| LM2902KDBRG4 | ACTIVE | SSOP | DB | 14 | 2000 | Green (RoHS & no Sb/Br) | CU NIPDAU | Level-1-260C-UNLIM |
| LM2902KDE4 | ACTIVE | SOIC | D | 14 | 50 | Green (RoHS & no Sb/Br) | CU NIPDAU | Level-1-260C-UNLIM |
| LM2902KDG4 | ACTIVE | SOIC | D | 14 | 50 | Green (RoHS & no Sb/Br) | CU NIPDAU | Level-1-260C-UNLIM |
| LM2902KDR | ACTIVE | SOIC | D | 14 | 2500 | Green (RoHS & no Sb/Br) | CU NIPDAU | Level-1-260C-UNLIM |
| LM2902KDRE4 | ACTIVE | SOIC | D | 14 | 2500 | Green (RoHS & no Sb/Br) | CU NIPDAU | Level-1-260C-UNLIM |
| LM2902KDRG4 | ACTIVE | SOIC | D | 14 | 2500 | Green (RoHS & no Sb/Br) | CU NIPDAU | Level-1-260C-UNLIM |
| LM2902KN | ACTIVE | PDIP | N | 14 | 25 | Pb-Free (RoHS) | CU NIPDAU | N / A for Pkg Type |
| LM2902KNE4 | ACTIVE | PDIP | N | 14 | 25 | Pb-Free (RoHS) | CU NIPDAU | N / A for Pkg Type |
| LM2902KNSR | ACTIVE | SO | NS | 14 | 2000 | Green (RoHS & no Sb/Br) | CU NIPDAU | Level-1-260C-UNLIM |
| LM2902KNSRE4 | ACTIVE | SO | NS | 14 | 2000 | Green (RoHS & no Sb/Br) | CU NIPDAU | Level-1-260C-UNLIM |
| LM2902KNSRG4 | ACTIVE | SO | NS | 14 | 2000 | Green (RoHS & no Sb/Br) | CU NIPDAU | Level-1-260C-UNLIM |
| LM2902KPW | ACTIVE | TSSOP | PW | 14 | 90 | Green (RoHS & no Sb/Br) | CU NIPDAU | Level-1-260C-UNLIM |
| LM2902KPWE4 | ACTIVE | TSSOP | PW | 14 | 90 | Green (RoHS & no Sb/Br) | CU NIPDAU | Level-1-260C-UNLIM |
| LM2902KPWG4 | ACTIVE | TSSOP | PW | 14 | 90 | Green (RoHS & no Sb/Br) | CU NIPDAU | Level-1-260C-UNLIM |

| Orderable Device | Status ⁽¹⁾ | Package Type | Package Drawing | Pins | Package Qty | Eco Plan ⁽²⁾ | Lead/Ball Finish | MSL Peak Temp ⁽³⁾ |
|------------------|-----------------------|--------------|-----------------|------|-------------|-------------------------|------------------|------------------------------|
| LM2902KPWR | ACTIVE | TSSOP | PW | 14 | 2000 | Green (RoHS & no Sb/Br) | CU NIPDAU | Level-1-260C-UNLIM |
| LM2902KPWRE4 | ACTIVE | TSSOP | PW | 14 | 2000 | Green (RoHS & no Sb/Br) | CU NIPDAU | Level-1-260C-UNLIM |
| LM2902KPWRG4 | ACTIVE | TSSOP | PW | 14 | 2000 | Green (RoHS & no Sb/Br) | CU NIPDAU | Level-1-260C-UNLIM |
| LM2902KVQDR | ACTIVE | SOIC | D | 14 | 2500 | Green (RoHS & no Sb/Br) | CU NIPDAU | Level-1-260C-UNLIM |
| LM2902KVQDRG4 | ACTIVE | SOIC | D | 14 | 2500 | Green (RoHS & no Sb/Br) | CU NIPDAU | Level-1-260C-UNLIM |
| LM2902KVQPWR | ACTIVE | TSSOP | PW | 14 | 2000 | TBD | CU NIPDAU | Level-1-250C-UNLIM |
| LM2902KVQPWRG4 | ACTIVE | TSSOP | PW | 14 | 2000 | Green (RoHS & no Sb/Br) | CU NIPDAU | Level-1-260C-UNLIM |
| LM2902N | ACTIVE | PDIP | N | 14 | 25 | Pb-Free (RoHS) | CU NIPDAU | N / A for Pkg Type |
| LM2902NE4 | ACTIVE | PDIP | N | 14 | 25 | Pb-Free (RoHS) | CU NIPDAU | N / A for Pkg Type |
| LM2902NSR | ACTIVE | SO | NS | 14 | 2000 | Green (RoHS & no Sb/Br) | CU NIPDAU | Level-1-260C-UNLIM |
| LM2902NSRG4 | ACTIVE | SO | NS | 14 | 2000 | Green (RoHS & no Sb/Br) | CU NIPDAU | Level-1-260C-UNLIM |
| LM2902PW | ACTIVE | TSSOP | PW | 14 | 90 | Green (RoHS & no Sb/Br) | CU NIPDAU | Level-1-260C-UNLIM |
| LM2902PWE4 | ACTIVE | TSSOP | PW | 14 | 90 | Green (RoHS & no Sb/Br) | CU NIPDAU | Level-1-260C-UNLIM |
| LM2902PWG4 | ACTIVE | TSSOP | PW | 14 | 90 | Green (RoHS & no Sb/Br) | CU NIPDAU | Level-1-260C-UNLIM |
| LM2902PWLE | OBSOLETE | TSSOP | PW | 14 | | TBD | Call TI | Call TI |
| LM2902PWR | ACTIVE | TSSOP | PW | 14 | 2000 | Green (RoHS & no Sb/Br) | CU NIPDAU | Level-1-260C-UNLIM |
| LM2902PWRE4 | ACTIVE | TSSOP | PW | 14 | 2000 | Green (RoHS & no Sb/Br) | CU NIPDAU | Level-1-260C-UNLIM |
| LM2902PWRG3 | PREVIEW | TSSOP | PW | 14 | 2500 | TBD | Call TI | Call TI |
| LM2902PWRG4 | ACTIVE | TSSOP | PW | 14 | 2000 | Green (RoHS & no Sb/Br) | CU NIPDAU | Level-1-260C-UNLIM |
| LM2902QN | OBSOLETE | PDIP | N | 14 | | TBD | Call TI | Call TI |
| LM324AD | ACTIVE | SOIC | D | 14 | 50 | Green (RoHS & no Sb/Br) | CU NIPDAU | Level-1-260C-UNLIM |
| LM324ADBLE | OBSOLETE | SSOP | DB | 14 | | TBD | Call TI | Call TI |
| LM324ADBR | ACTIVE | SSOP | DB | 14 | 2000 | Green (RoHS & no Sb/Br) | CU NIPDAU | Level-1-260C-UNLIM |
| LM324ADBRE4 | ACTIVE | SSOP | DB | 14 | 2000 | Green (RoHS & no Sb/Br) | CU NIPDAU | Level-1-260C-UNLIM |
| LM324ADBRG4 | ACTIVE | SSOP | DB | 14 | 2000 | Green (RoHS & no Sb/Br) | CU NIPDAU | Level-1-260C-UNLIM |
| LM324ADE4 | ACTIVE | SOIC | D | 14 | 50 | Green (RoHS & no Sb/Br) | CU NIPDAU | Level-1-260C-UNLIM |
| LM324ADG4 | ACTIVE | SOIC | D | 14 | 50 | Green (RoHS & no Sb/Br) | CU NIPDAU | Level-1-260C-UNLIM |
| LM324ADR | ACTIVE | SOIC | D | 14 | 2500 | Green (RoHS & no Sb/Br) | CU NIPDAU | Level-1-260C-UNLIM |

| Orderable Device | Status ⁽¹⁾ | Package Type | Package Drawing | Pins | Package Qty | Eco Plan ⁽²⁾ | Lead/Ball Finish | MSL Peak Temp ⁽³⁾ |
|------------------|-----------------------|--------------|-----------------|------|-------------|-------------------------|------------------|------------------------------|
| LM324ADRE4 | ACTIVE | SOIC | D | 14 | 2500 | Green (RoHS & no Sb/Br) | CU NIPDAU | Level-1-260C-UNLIM |
| LM324ADRG4 | ACTIVE | SOIC | D | 14 | 2500 | Green (RoHS & no Sb/Br) | CU NIPDAU | Level-1-260C-UNLIM |
| LM324AN | ACTIVE | PDIP | N | 14 | 25 | Pb-Free (RoHS) | CU NIPDAU | N / A for Pkg Type |
| LM324ANE4 | ACTIVE | PDIP | N | 14 | 25 | Pb-Free (RoHS) | CU NIPDAU | N / A for Pkg Type |
| LM324ANSR | ACTIVE | SO | NS | 14 | 2000 | Green (RoHS & no Sb/Br) | CU NIPDAU | Level-1-260C-UNLIM |
| LM324ANSRE4 | ACTIVE | SO | NS | 14 | 2000 | Green (RoHS & no Sb/Br) | CU NIPDAU | Level-1-260C-UNLIM |
| LM324ANSRG4 | ACTIVE | SO | NS | 14 | 2000 | Green (RoHS & no Sb/Br) | CU NIPDAU | Level-1-260C-UNLIM |
| LM324APW | ACTIVE | TSSOP | PW | 14 | 90 | Green (RoHS & no Sb/Br) | CU NIPDAU | Level-1-260C-UNLIM |
| LM324APWE4 | ACTIVE | TSSOP | PW | 14 | 90 | Green (RoHS & no Sb/Br) | CU NIPDAU | Level-1-260C-UNLIM |
| LM324APWG4 | ACTIVE | TSSOP | PW | 14 | 90 | Green (RoHS & no Sb/Br) | CU NIPDAU | Level-1-260C-UNLIM |
| LM324APWLE | OBSOLETE | TSSOP | PW | 14 | | TBD | Call TI | Call TI |
| LM324APWR | ACTIVE | TSSOP | PW | 14 | 2000 | Green (RoHS & no Sb/Br) | CU NIPDAU | Level-1-260C-UNLIM |
| LM324APWRE4 | ACTIVE | TSSOP | PW | 14 | 2000 | Green (RoHS & no Sb/Br) | CU NIPDAU | Level-1-260C-UNLIM |
| LM324APWRG4 | ACTIVE | TSSOP | PW | 14 | 2000 | Green (RoHS & no Sb/Br) | CU NIPDAU | Level-1-260C-UNLIM |
| LM324D | ACTIVE | SOIC | D | 14 | 50 | Green (RoHS & no Sb/Br) | CU NIPDAU | Level-1-260C-UNLIM |
| LM324DE4 | ACTIVE | SOIC | D | 14 | 50 | Green (RoHS & no Sb/Br) | CU NIPDAU | Level-1-260C-UNLIM |
| LM324DG4 | ACTIVE | SOIC | D | 14 | 50 | Green (RoHS & no Sb/Br) | CU NIPDAU | Level-1-260C-UNLIM |
| LM324DR | ACTIVE | SOIC | D | 14 | 2500 | Green (RoHS & no Sb/Br) | CU NIPDAU | Level-1-260C-UNLIM |
| LM324DRE4 | ACTIVE | SOIC | D | 14 | 2500 | Green (RoHS & no Sb/Br) | CU NIPDAU | Level-1-260C-UNLIM |
| LM324DRG3 | ACTIVE | SOIC | D | 14 | 2500 | Green (RoHS & no Sb/Br) | CU | Level-1-260C-UNLIM |
| LM324DRG4 | ACTIVE | SOIC | D | 14 | 2500 | Green (RoHS & no Sb/Br) | CU NIPDAU | Level-1-260C-UNLIM |
| LM324KAD | ACTIVE | SOIC | D | 14 | 50 | Green (RoHS & no Sb/Br) | CU NIPDAU | Level-1-260C-UNLIM |
| LM324KADE4 | ACTIVE | SOIC | D | 14 | 50 | Green (RoHS & no Sb/Br) | CU NIPDAU | Level-1-260C-UNLIM |
| LM324KADG4 | ACTIVE | SOIC | D | 14 | 50 | Green (RoHS & no Sb/Br) | CU NIPDAU | Level-1-260C-UNLIM |
| LM324KADR | ACTIVE | SOIC | D | 14 | 2500 | Green (RoHS & no Sb/Br) | CU NIPDAU | Level-1-260C-UNLIM |
| LM324KADRE4 | ACTIVE | SOIC | D | 14 | 2500 | Green (RoHS & no Sb/Br) | CU NIPDAU | Level-1-260C-UNLIM |

| Orderable Device | Status ⁽¹⁾ | Package Type | Package Drawing | Pins | Package Qty | Eco Plan ⁽²⁾ | Lead/Ball Finish | MSL Peak Temp ⁽³⁾ |
|------------------|-----------------------|--------------|-----------------|------|-------------|-------------------------|------------------|------------------------------|
| LM324KADRG4 | ACTIVE | SOIC | D | 14 | 2500 | Green (RoHS & no Sb/Br) | CU NIPDAU | Level-1-260C-UNLIM |
| LM324KAN | ACTIVE | PDIP | N | 14 | 25 | Pb-Free (RoHS) | CU NIPDAU | N / A for Pkg Type |
| LM324KANE4 | ACTIVE | PDIP | N | 14 | 25 | Pb-Free (RoHS) | CU NIPDAU | N / A for Pkg Type |
| LM324KANS | PREVIEW | SO | NS | 14 | 50 | Green (RoHS & no Sb/Br) | CU NIPDAU | Level-1-260C-UNLIM |
| LM324KANSG4 | PREVIEW | SO | NS | 14 | 50 | Green (RoHS & no Sb/Br) | CU NIPDAU | Level-1-260C-UNLIM |
| LM324KANSR | ACTIVE | SO | NS | 14 | 2000 | Green (RoHS & no Sb/Br) | CU NIPDAU | Level-1-260C-UNLIM |
| LM324KANSRE4 | ACTIVE | SO | NS | 14 | 2000 | Green (RoHS & no Sb/Br) | CU NIPDAU | Level-1-260C-UNLIM |
| LM324KANSRG4 | ACTIVE | SO | NS | 14 | 2000 | Green (RoHS & no Sb/Br) | CU NIPDAU | Level-1-260C-UNLIM |
| LM324KAPW | ACTIVE | TSSOP | PW | 14 | 90 | Green (RoHS & no Sb/Br) | CU NIPDAU | Level-1-260C-UNLIM |
| LM324KAPWE4 | ACTIVE | TSSOP | PW | 14 | 90 | Green (RoHS & no Sb/Br) | CU NIPDAU | Level-1-260C-UNLIM |
| LM324KAPWG4 | ACTIVE | TSSOP | PW | 14 | 90 | Green (RoHS & no Sb/Br) | CU NIPDAU | Level-1-260C-UNLIM |
| LM324KAPWR | ACTIVE | TSSOP | PW | 14 | 2000 | Green (RoHS & no Sb/Br) | CU NIPDAU | Level-1-260C-UNLIM |
| LM324KAPWRE4 | ACTIVE | TSSOP | PW | 14 | 2000 | Green (RoHS & no Sb/Br) | CU NIPDAU | Level-1-260C-UNLIM |
| LM324KAPWRG4 | ACTIVE | TSSOP | PW | 14 | 2000 | Green (RoHS & no Sb/Br) | CU NIPDAU | Level-1-260C-UNLIM |
| LM324KD | ACTIVE | SOIC | D | 14 | 50 | Green (RoHS & no Sb/Br) | CU NIPDAU | Level-1-260C-UNLIM |
| LM324KDE4 | ACTIVE | SOIC | D | 14 | 50 | Green (RoHS & no Sb/Br) | CU NIPDAU | Level-1-260C-UNLIM |
| LM324KDG4 | ACTIVE | SOIC | D | 14 | 50 | Green (RoHS & no Sb/Br) | CU NIPDAU | Level-1-260C-UNLIM |
| LM324KDR | ACTIVE | SOIC | D | 14 | 2500 | Green (RoHS & no Sb/Br) | CU NIPDAU | Level-1-260C-UNLIM |
| LM324KDRE4 | ACTIVE | SOIC | D | 14 | 2500 | Green (RoHS & no Sb/Br) | CU NIPDAU | Level-1-260C-UNLIM |
| LM324KDRG4 | ACTIVE | SOIC | D | 14 | 2500 | Green (RoHS & no Sb/Br) | CU NIPDAU | Level-1-260C-UNLIM |
| LM324KN | ACTIVE | PDIP | N | 14 | 25 | Pb-Free (RoHS) | CU NIPDAU | N / A for Pkg Type |
| LM324KNE4 | ACTIVE | PDIP | N | 14 | 25 | Pb-Free (RoHS) | CU NIPDAU | N / A for Pkg Type |
| LM324KNS | PREVIEW | SO | NS | 14 | 50 | Green (RoHS & no Sb/Br) | CU NIPDAU | Level-1-260C-UNLIM |
| LM324KNSG4 | PREVIEW | SO | NS | 14 | 50 | Green (RoHS & no Sb/Br) | CU NIPDAU | Level-1-260C-UNLIM |
| LM324KNSR | ACTIVE | SO | NS | 14 | 2000 | Green (RoHS & no Sb/Br) | CU NIPDAU | Level-1-260C-UNLIM |
| LM324KNSRE4 | ACTIVE | SO | NS | 14 | 2000 | Green (RoHS & no Sb/Br) | CU NIPDAU | Level-1-260C-UNLIM |

| Orderable Device | Status ⁽¹⁾ | Package Type | Package Drawing | Pins | Package Qty | Eco Plan ⁽²⁾ | Lead/Ball Finish | MSL Peak Temp ⁽³⁾ |
|------------------|-----------------------|--------------|-----------------|------|-------------|-------------------------|------------------|------------------------------|
| LM324KNSRG4 | ACTIVE | SO | NS | 14 | 2000 | Green (RoHS & no Sb/Br) | CU NIPDAU | Level-1-260C-UNLIM |
| LM324KPW | ACTIVE | TSSOP | PW | 14 | 90 | Green (RoHS & no Sb/Br) | CU NIPDAU | Level-1-260C-UNLIM |
| LM324KPWE4 | ACTIVE | TSSOP | PW | 14 | 90 | Green (RoHS & no Sb/Br) | CU NIPDAU | Level-1-260C-UNLIM |
| LM324KPWG4 | ACTIVE | TSSOP | PW | 14 | 90 | Green (RoHS & no Sb/Br) | CU NIPDAU | Level-1-260C-UNLIM |
| LM324KPWR | ACTIVE | TSSOP | PW | 14 | 2000 | Green (RoHS & no Sb/Br) | CU NIPDAU | Level-1-260C-UNLIM |
| LM324KPWRE4 | ACTIVE | TSSOP | PW | 14 | 2000 | Green (RoHS & no Sb/Br) | CU NIPDAU | Level-1-260C-UNLIM |
| LM324KPWRG4 | ACTIVE | TSSOP | PW | 14 | 2000 | Green (RoHS & no Sb/Br) | CU NIPDAU | Level-1-260C-UNLIM |
| LM324N | ACTIVE | PDIP | N | 14 | 25 | Pb-Free (RoHS) | CU NIPDAU | N / A for Pkg Type |
| LM324NE3 | PREVIEW | PDIP | N | 14 | 25 | TBD | Call TI | Call TI |
| LM324NE4 | ACTIVE | PDIP | N | 14 | 25 | Pb-Free (RoHS) | CU NIPDAU | N / A for Pkg Type |
| LM324NSR | ACTIVE | SO | NS | 14 | 2000 | Green (RoHS & no Sb/Br) | CU NIPDAU | Level-1-260C-UNLIM |
| LM324NSRE4 | ACTIVE | SO | NS | 14 | 2000 | Green (RoHS & no Sb/Br) | CU NIPDAU | Level-1-260C-UNLIM |
| LM324NSRG4 | ACTIVE | SO | NS | 14 | 2000 | Green (RoHS & no Sb/Br) | CU NIPDAU | Level-1-260C-UNLIM |
| LM324PW | ACTIVE | TSSOP | PW | 14 | 90 | Green (RoHS & no Sb/Br) | CU NIPDAU | Level-1-260C-UNLIM |
| LM324PWE4 | ACTIVE | TSSOP | PW | 14 | 90 | Green (RoHS & no Sb/Br) | CU NIPDAU | Level-1-260C-UNLIM |
| LM324PWG4 | ACTIVE | TSSOP | PW | 14 | 90 | Green (RoHS & no Sb/Br) | CU NIPDAU | Level-1-260C-UNLIM |
| LM324PWLE | OBSOLETE | TSSOP | PW | 14 | | TBD | Call TI | Call TI |
| LM324PWR | ACTIVE | TSSOP | PW | 14 | 2000 | Green (RoHS & no Sb/Br) | CU NIPDAU | Level-1-260C-UNLIM |
| LM324PWRE4 | ACTIVE | TSSOP | PW | 14 | 2000 | Green (RoHS & no Sb/Br) | CU NIPDAU | Level-1-260C-UNLIM |
| LM324PWRG3 | PREVIEW | TSSOP | PW | 14 | 2000 | TBD | Call TI | Call TI |
| LM324PWRG4 | ACTIVE | TSSOP | PW | 14 | 2000 | Green (RoHS & no Sb/Br) | CU NIPDAU | Level-1-260C-UNLIM |
| LM324Y | OBSOLETE | DIESALE | Y | 0 | | TBD | Call TI | Call TI |

⁽¹⁾ The marketing status values are defined as follows:

ACTIVE: Product device recommended for new designs.

LIFEBUY: TI has announced that the device will be discontinued, and a lifetime-buy period is in effect.

NRND: Not recommended for new designs. Device is in production to support existing customers, but TI does not recommend using this part in a new design.

PREVIEW: Device has been announced but is not in production. Samples may or may not be available.

OBSOLETE: TI has discontinued the production of the device.

⁽²⁾ Eco Plan - The planned eco-friendly classification: Pb-Free (RoHS), Pb-Free (RoHS Exempt), or Green (RoHS & no Sb/Br) - please check <http://www.ti.com/productcontent> for the latest availability information and additional product content details.

TBD: The Pb-Free/Green conversion plan has not been defined.

Pb-Free (RoHS): TI's terms "Lead-Free" or "Pb-Free" mean semiconductor products that are compatible with the current RoHS requirements

for all 6 substances, including the requirement that lead not exceed 0.1% by weight in homogeneous materials. Where designed to be soldered at high temperatures, TI Pb-Free products are suitable for use in specified lead-free processes.

Pb-Free (RoHS Exempt): This component has a RoHS exemption for either 1) lead-based flip-chip solder bumps used between the die and package, or 2) lead-based die adhesive used between the die and leadframe. The component is otherwise considered Pb-Free (RoHS compatible) as defined above.

Green (RoHS & no Sb/Br): TI defines "Green" to mean Pb-Free (RoHS compatible), and free of Bromine (Br) and Antimony (Sb) based flame retardants (Br or Sb do not exceed 0.1% by weight in homogeneous material)

(3) MSL, Peak Temp. -- The Moisture Sensitivity Level rating according to the JEDEC industry standard classifications, and peak solder temperature.

Important Information and Disclaimer:The information provided on this page represents TI's knowledge and belief as of the date that it is provided. TI bases its knowledge and belief on information provided by third parties, and makes no representation or warranty as to the accuracy of such information. Efforts are underway to better integrate information from third parties. TI has taken and continues to take reasonable steps to provide representative and accurate information but may not have conducted destructive testing or chemical analysis on incoming materials and chemicals. TI and TI suppliers consider certain information to be proprietary, and thus CAS numbers and other limited information may not be available for release.

In no event shall TI's liability arising out of such information exceed the total purchase price of the TI part(s) at issue in this document sold by TI to Customer on an annual basis.

OTHER QUALIFIED VERSIONS OF LM124, LM124-SP, LM124M, LM2902 :

- Automotive: [LM2902-Q1](#)
- Enhanced Product: [LM2902-EP](#)

NOTE: Qualified Version Definitions:

- Automotive - Q100 devices qualified for high-reliability automotive applications targeting zero defects
- Enhanced Product - Supports Defense, Aerospace and Medical Applications

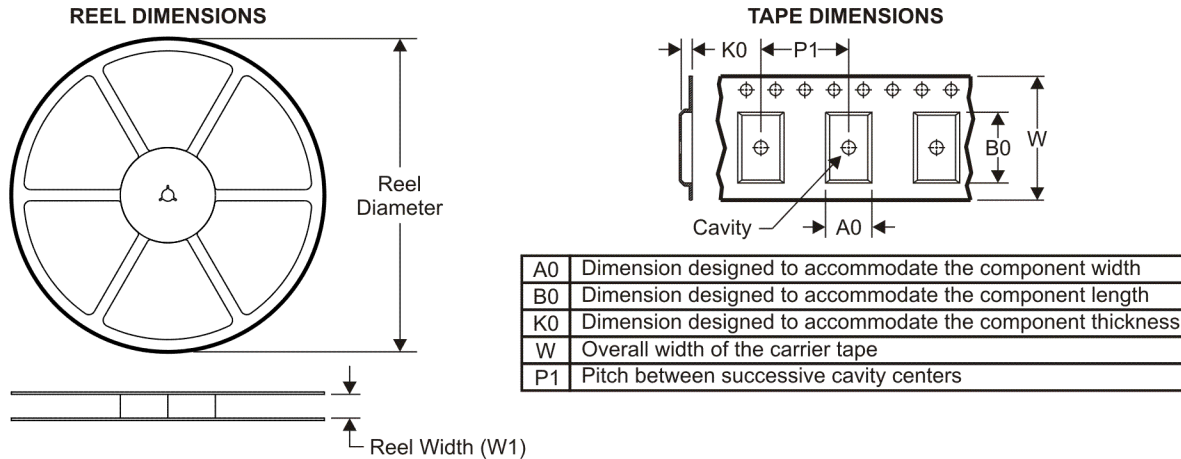
TAPE AND REEL INFORMATION

QUADRANT ASSIGNMENTS FOR PIN 1 ORIENTATION IN TAPE

*All dimensions are nominal

| Device | Package Type | Package Drawing | Pins | SPQ | Reel Diameter (mm) | Reel Width W1 (mm) | A0 (mm) | B0 (mm) | K0 (mm) | P1 (mm) | W (mm) | Pin1 Quadrant |
|------------|--------------|-----------------|------|------|--------------------|--------------------|---------|---------|---------|---------|--------|---------------|
| LM224ADR | SOIC | D | 14 | 2500 | 330.0 | 16.4 | 6.5 | 9.0 | 2.1 | 8.0 | 16.0 | Q1 |
| LM224DR | SOIC | D | 14 | 2500 | 330.0 | 16.4 | 6.5 | 9.0 | 2.1 | 8.0 | 16.0 | Q1 |
| LM224KADR | SOIC | D | 14 | 2500 | 330.0 | 16.4 | 6.5 | 9.0 | 2.1 | 8.0 | 16.0 | Q1 |
| LM224KDR | SOIC | D | 14 | 2500 | 330.0 | 16.4 | 6.5 | 9.0 | 2.1 | 8.0 | 16.0 | Q1 |
| LM2902DR | SOIC | D | 14 | 2500 | 330.0 | 16.4 | 6.5 | 9.0 | 2.1 | 8.0 | 16.0 | Q1 |
| LM2902DR | SOIC | D | 14 | 2500 | 330.0 | 16.4 | 6.5 | 9.0 | 2.1 | 8.0 | 16.0 | Q1 |
| LM2902KDBR | SSOP | DB | 14 | 2000 | 330.0 | 16.4 | 8.2 | 6.6 | 2.5 | 12.0 | 16.0 | Q1 |
| LM2902KDR | SOIC | D | 14 | 2500 | 330.0 | 16.4 | 6.5 | 9.0 | 2.1 | 8.0 | 16.0 | Q1 |
| LM2902KNSR | SO | NS | 14 | 2000 | 330.0 | 16.4 | 8.2 | 10.5 | 2.5 | 12.0 | 16.0 | Q1 |
| LM2902KPWR | TSSOP | PW | 14 | 2000 | 330.0 | 12.4 | 7.0 | 5.6 | 1.6 | 8.0 | 12.0 | Q1 |
| LM2902NSR | SO | NS | 14 | 2000 | 330.0 | 16.4 | 8.2 | 10.5 | 2.5 | 12.0 | 16.0 | Q1 |
| LM2902PWR | TSSOP | PW | 14 | 2000 | 330.0 | 12.4 | 7.0 | 5.6 | 1.6 | 8.0 | 12.0 | Q1 |
| LM324ADBR | SSOP | DB | 14 | 2000 | 330.0 | 16.4 | 8.2 | 6.6 | 2.5 | 12.0 | 16.0 | Q1 |
| LM324ADR | SOIC | D | 14 | 2500 | 330.0 | 16.4 | 6.5 | 9.0 | 2.1 | 8.0 | 16.0 | Q1 |
| LM324ANSR | SO | NS | 14 | 2000 | 330.0 | 16.4 | 8.2 | 10.5 | 2.5 | 12.0 | 16.0 | Q1 |
| LM324APWR | TSSOP | PW | 14 | 2000 | 330.0 | 12.4 | 7.0 | 5.6 | 1.6 | 8.0 | 12.0 | Q1 |
| LM324DR | SOIC | D | 14 | 2500 | 330.0 | 16.4 | 6.5 | 9.0 | 2.1 | 8.0 | 16.0 | Q1 |
| LM324DR | SOIC | D | 14 | 2500 | 330.0 | 16.4 | 6.55 | 9.05 | 2.1 | 8.0 | 16.0 | Q1 |

| Device | Package Type | Package Drawing | Pins | SPQ | Reel Diameter (mm) | Reel Width W1 (mm) | A0 (mm) | B0 (mm) | K0 (mm) | P1 (mm) | W (mm) | Pin1 Quadrant |
|------------|--------------|-----------------|------|------|--------------------|--------------------|---------|---------|---------|---------|--------|---------------|
| LM324DR | SOIC | D | 14 | 2500 | 330.0 | 16.4 | 6.5 | 9.0 | 2.1 | 8.0 | 16.0 | Q1 |
| LM324KADR | SOIC | D | 14 | 2500 | 330.0 | 16.4 | 6.5 | 9.0 | 2.1 | 8.0 | 16.0 | Q1 |
| LM324KANSR | SO | NS | 14 | 2000 | 330.0 | 16.4 | 8.2 | 10.5 | 2.5 | 12.0 | 16.0 | Q1 |
| LM324KAPWR | TSSOP | PW | 14 | 2000 | 330.0 | 12.4 | 7.0 | 5.6 | 1.6 | 8.0 | 12.0 | Q1 |
| LM324KDR | SOIC | D | 14 | 2500 | 330.0 | 16.4 | 6.5 | 9.0 | 2.1 | 8.0 | 16.0 | Q1 |
| LM324KNSR | SO | NS | 14 | 2000 | 330.0 | 16.4 | 8.2 | 10.5 | 2.5 | 12.0 | 16.0 | Q1 |
| LM324KPWR | TSSOP | PW | 14 | 2000 | 330.0 | 12.4 | 7.0 | 5.6 | 1.6 | 8.0 | 12.0 | Q1 |
| LM324NSR | SO | NS | 14 | 2000 | 330.0 | 16.4 | 8.2 | 10.5 | 2.5 | 12.0 | 16.0 | Q1 |
| LM324PWR | TSSOP | PW | 14 | 2000 | 330.0 | 12.4 | 7.0 | 5.6 | 1.6 | 8.0 | 12.0 | Q1 |

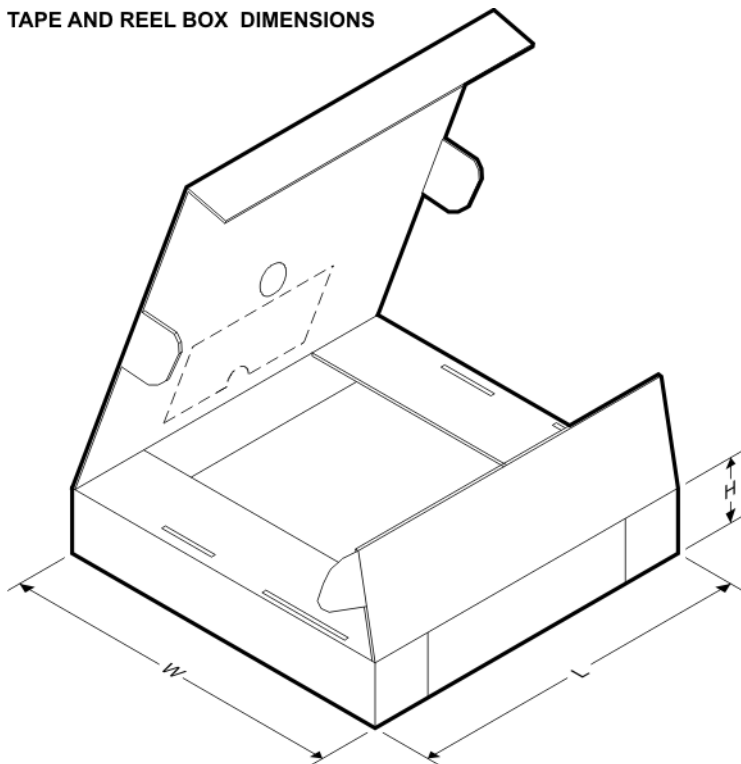
TAPE AND REEL BOX DIMENSIONS



*All dimensions are nominal

| Device | Package Type | Package Drawing | Pins | SPQ | Length (mm) | Width (mm) | Height (mm) |
|------------|--------------|-----------------|------|------|-------------|------------|-------------|
| LM224ADR | SOIC | D | 14 | 2500 | 346.0 | 346.0 | 33.0 |
| LM224DR | SOIC | D | 14 | 2500 | 346.0 | 346.0 | 33.0 |
| LM224KADR | SOIC | D | 14 | 2500 | 346.0 | 346.0 | 33.0 |
| LM224KDR | SOIC | D | 14 | 2500 | 346.0 | 346.0 | 33.0 |
| LM2902DR | SOIC | D | 14 | 2500 | 333.2 | 345.9 | 28.6 |
| LM2902DR | SOIC | D | 14 | 2500 | 346.0 | 346.0 | 33.0 |
| LM2902KDBR | SSOP | DB | 14 | 2000 | 346.0 | 346.0 | 33.0 |
| LM2902KDR | SOIC | D | 14 | 2500 | 346.0 | 346.0 | 33.0 |

| Device | Package Type | Package Drawing | Pins | SPQ | Length (mm) | Width (mm) | Height (mm) |
|------------|--------------|-----------------|------|------|-------------|------------|-------------|
| LM2902KNSR | SO | NS | 14 | 2000 | 346.0 | 346.0 | 33.0 |
| LM2902KPWR | TSSOP | PW | 14 | 2000 | 346.0 | 346.0 | 29.0 |
| LM2902NSR | SO | NS | 14 | 2000 | 346.0 | 346.0 | 33.0 |
| LM2902PWR | TSSOP | PW | 14 | 2000 | 346.0 | 346.0 | 29.0 |
| LM324ADBR | SSOP | DB | 14 | 2000 | 346.0 | 346.0 | 33.0 |
| LM324ADR | SOIC | D | 14 | 2500 | 346.0 | 346.0 | 33.0 |
| LM324ANSR | SO | NS | 14 | 2000 | 346.0 | 346.0 | 33.0 |
| LM324APWR | TSSOP | PW | 14 | 2000 | 346.0 | 346.0 | 29.0 |
| LM324DR | SOIC | D | 14 | 2500 | 346.0 | 346.0 | 33.0 |
| LM324DR | SOIC | D | 14 | 2500 | 385.0 | 388.0 | 194.0 |
| LM324DR | SOIC | D | 14 | 2500 | 333.2 | 345.9 | 28.6 |
| LM324KADR | SOIC | D | 14 | 2500 | 346.0 | 346.0 | 33.0 |
| LM324KANSR | SO | NS | 14 | 2000 | 346.0 | 346.0 | 33.0 |
| LM324KAPWR | TSSOP | PW | 14 | 2000 | 346.0 | 346.0 | 29.0 |
| LM324KDR | SOIC | D | 14 | 2500 | 346.0 | 346.0 | 33.0 |
| LM324KNSR | SO | NS | 14 | 2000 | 346.0 | 346.0 | 33.0 |
| LM324KPWR | TSSOP | PW | 14 | 2000 | 346.0 | 346.0 | 29.0 |
| LM324NSR | SO | NS | 14 | 2000 | 346.0 | 346.0 | 33.0 |
| LM324PWR | TSSOP | PW | 14 | 2000 | 346.0 | 346.0 | 29.0 |

J (R-GDIP-T**)

14 LEADS SHOWN

CERAMIC DUAL IN-LINE PACKAGE



| DIM \ PINS ** | 14 | 16 | 18 | 20 |
|---------------|------------------------|------------------------|------------------------|------------------------|
| A | 0.300 (7,62) BSC | 0.300 (7,62) BSC | 0.300 (7,62) BSC | 0.300 (7,62) BSC |
| B MAX | 0.785 (19,94) | .840 (21,34) | 0.960 (24,38) | 1.060 (26,92) |
| B MIN | — | — | — | — |
| C MAX | 0.300 (7,62) | 0.300 (7,62) | 0.310 (7,87) | 0.300 (7,62) |
| C MIN | 0.245 (6,22) | 0.245 (6,22) | 0.220 (5,59) | 0.245 (6,22) |



4040083/F 03/03

- NOTES:
- All linear dimensions are in inches (millimeters).
 - This drawing is subject to change without notice.
 - This package is hermetically sealed with a ceramic lid using glass frit.
 - Index point is provided on cap for terminal identification only on press ceramic glass frit seal only.
 - Falls within MIL STD 1835 GDIP1-T14, GDIP1-T16, GDIP1-T18 and GDIP1-T20.

W (R-GDFP-F14)

CERAMIC DUAL FLATPACK

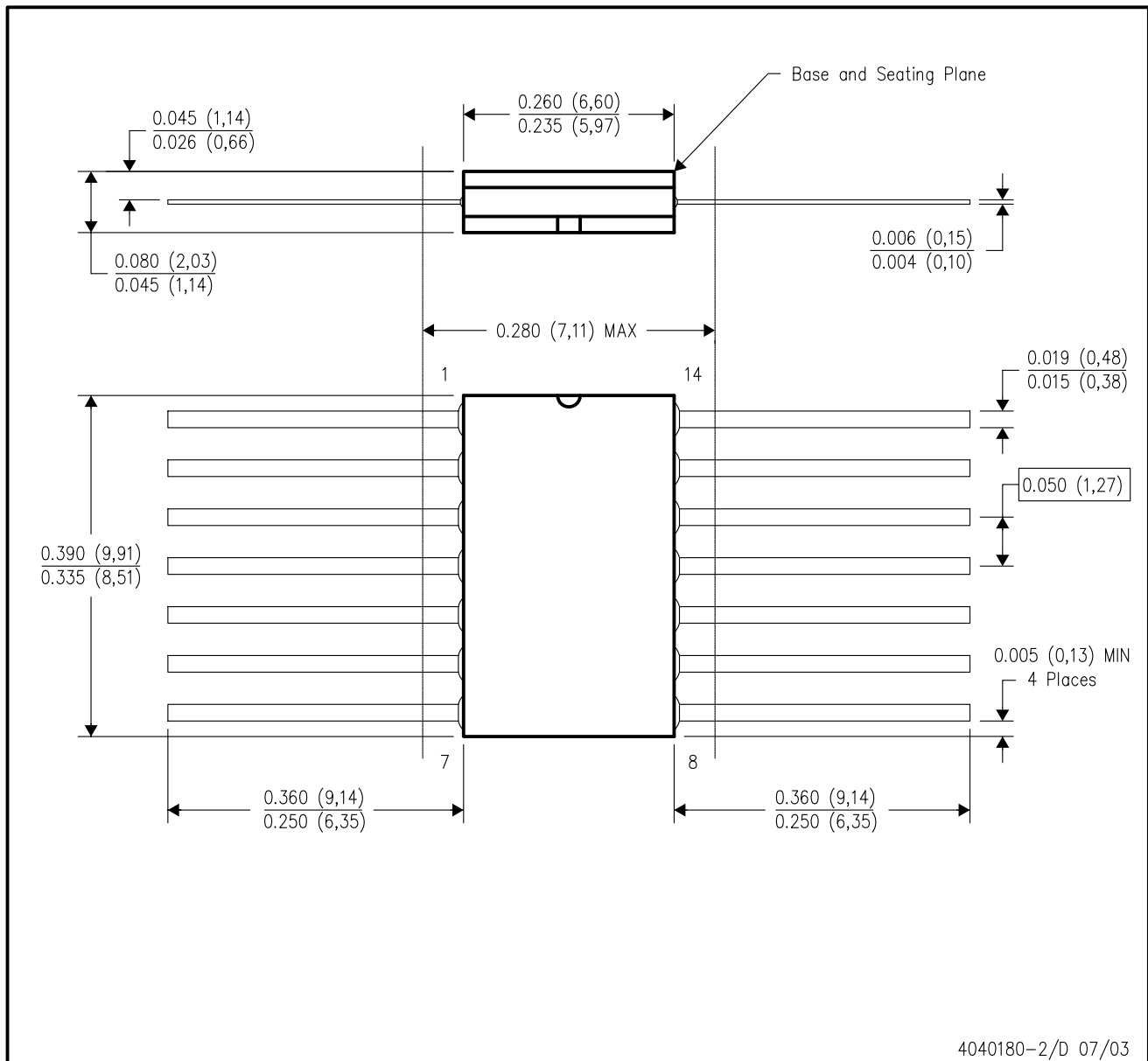

- NOTES:
- A. All linear dimensions are in inches (millimeters).
 - B. This drawing is subject to change without notice.
 - C. This package can be hermetically sealed with a ceramic lid using glass frit.
 - D. Index point is provided on cap for terminal identification only.
 - E. Falls within MIL STD 1835 GDFP1-F14 and JEDEC MO-092AB

FK (S-CQCC-N**)

LEADLESS CERAMIC CHIP CARRIER

28 TERMINAL SHOWN

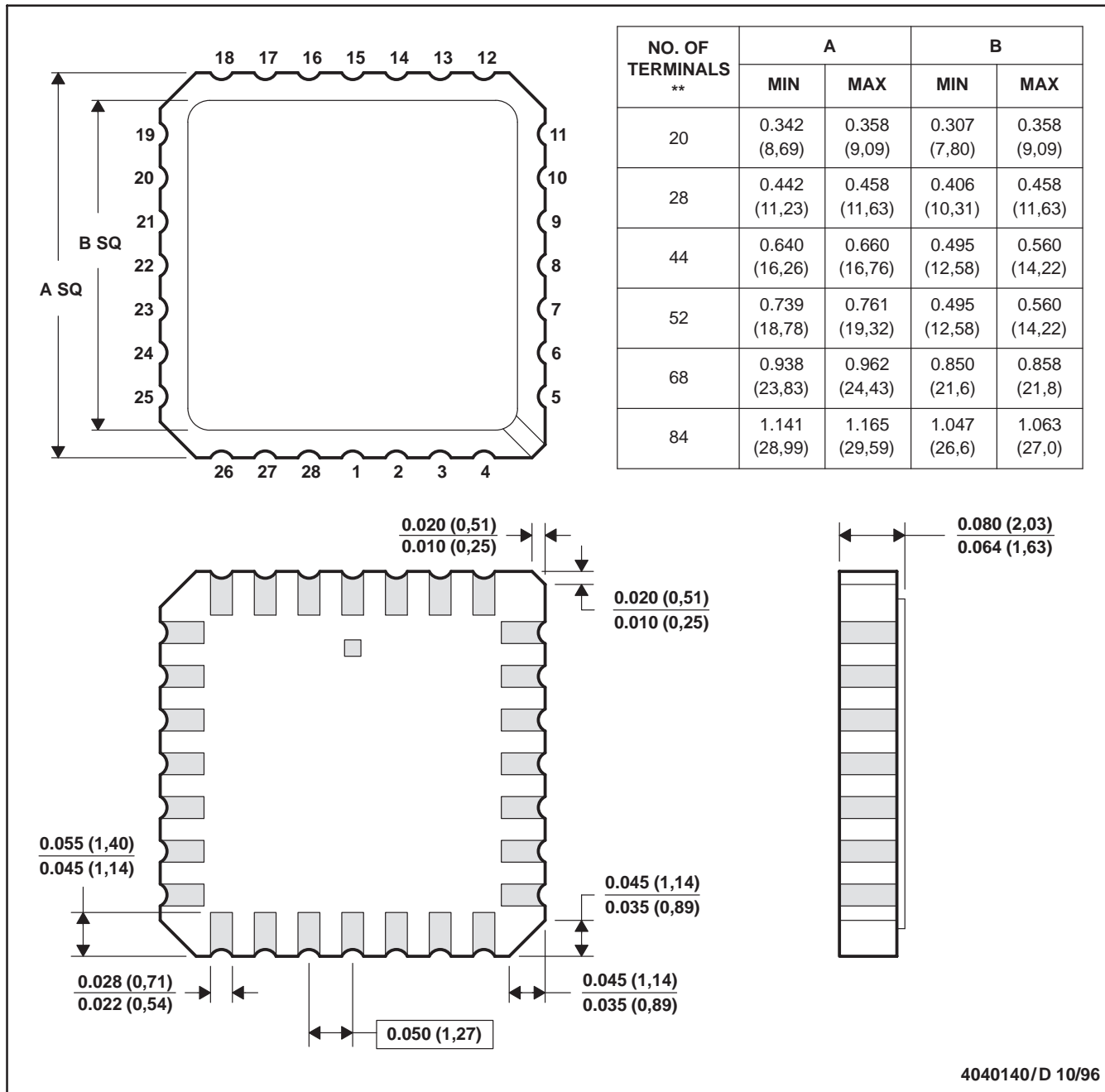

- NOTES:
- A. All linear dimensions are in inches (millimeters).
 - B. This drawing is subject to change without notice.
 - C. This package can be hermetically sealed with a metal lid.
 - D. The terminals are gold plated.
 - E. Falls within JEDEC MS-004

MECHANICAL DATA

NS (R-PDSO-G**)

PLASTIC SMALL-OUTLINE PACKAGE

14-PINS SHOWN



- NOTES:
- A. All linear dimensions are in millimeters.
 - B. This drawing is subject to change without notice.
 - C. Body dimensions do not include mold flash or protrusion, not to exceed 0,15.

DB (R-PDSO-G**)

PLASTIC SMALL-OUTLINE

28 PINS SHOWN



- NOTES: A. All linear dimensions are in millimeters.
 B. This drawing is subject to change without notice.
 C. Body dimensions do not include mold flash or protrusion not to exceed 0,15.
 D. Falls within JEDEC MO-150

PW (R-PDSO-G**)

PLASTIC SMALL-OUTLINE PACKAGE

14 PINS SHOWN



4040064/F 01/97

- NOTES: A. All linear dimensions are in millimeters.
 B. This drawing is subject to change without notice.
 C. Body dimensions do not include mold flash or protrusion not to exceed 0,15.
 D. Falls within JEDEC MO-153

IMPORTANT NOTICE

Texas Instruments Incorporated and its subsidiaries (TI) reserve the right to make corrections, modifications, enhancements, improvements, and other changes to its products and services at any time and to discontinue any product or service without notice. Customers should obtain the latest relevant information before placing orders and should verify that such information is current and complete. All products are sold subject to TI's terms and conditions of sale supplied at the time of order acknowledgment.

TI warrants performance of its hardware products to the specifications applicable at the time of sale in accordance with TI's standard warranty. Testing and other quality control techniques are used to the extent TI deems necessary to support this warranty. Except where mandated by government requirements, testing of all parameters of each product is not necessarily performed.

TI assumes no liability for applications assistance or customer product design. Customers are responsible for their products and applications using TI components. To minimize the risks associated with customer products and applications, customers should provide adequate design and operating safeguards.

TI does not warrant or represent that any license, either express or implied, is granted under any TI patent right, copyright, mask work right, or other TI intellectual property right relating to any combination, machine, or process in which TI products or services are used. Information published by TI regarding third-party products or services does not constitute a license from TI to use such products or services or a warranty or endorsement thereof. Use of such information may require a license from a third party under the patents or other intellectual property of the third party, or a license from TI under the patents or other intellectual property of TI.

Reproduction of TI information in TI data books or data sheets is permissible only if reproduction is without alteration and is accompanied by all associated warranties, conditions, limitations, and notices. Reproduction of this information with alteration is an unfair and deceptive business practice. TI is not responsible or liable for such altered documentation. Information of third parties may be subject to additional restrictions.

Resale of TI products or services with statements different from or beyond the parameters stated by TI for that product or service voids all express and any implied warranties for the associated TI product or service and is an unfair and deceptive business practice. TI is not responsible or liable for any such statements.

TI products are not authorized for use in safety-critical applications (such as life support) where a failure of the TI product would reasonably be expected to cause severe personal injury or death, unless officers of the parties have executed an agreement specifically governing such use. Buyers represent that they have all necessary expertise in the safety and regulatory ramifications of their applications, and acknowledge and agree that they are solely responsible for all legal, regulatory and safety-related requirements concerning their products and any use of TI products in such safety-critical applications, notwithstanding any applications-related information or support that may be provided by TI. Further, Buyers must fully indemnify TI and its representatives against any damages arising out of the use of TI products in such safety-critical applications.

TI products are neither designed nor intended for use in military/aerospace applications or environments unless the TI products are specifically designated by TI as military-grade or "enhanced plastic." Only products designated by TI as military-grade meet military specifications. Buyers acknowledge and agree that any such use of TI products which TI has not designated as military-grade is solely at the Buyer's risk, and that they are solely responsible for compliance with all legal and regulatory requirements in connection with such use.

TI products are neither designed nor intended for use in automotive applications or environments unless the specific TI products are designated by TI as compliant with ISO/TS 16949 requirements. Buyers acknowledge and agree that, if they use any non-designated products in automotive applications, TI will not be responsible for any failure to meet such requirements.

Following are URLs where you can obtain information on other Texas Instruments products and application solutions:

| Products | | Applications | |
|-----------------------------|--|----------------------------|--|
| Amplifiers | amplifier.ti.com | Audio | www.ti.com/audio |
| Data Converters | dataconverter.ti.com | Automotive | www.ti.com/automotive |
| DLP® Products | www.dlp.com | Communications and Telecom | www.ti.com/communications |
| DSP | dsp.ti.com | Computers and Peripherals | www.ti.com/computers |
| Clocks and Timers | www.ti.com/clocks | Consumer Electronics | www.ti.com/consumer-apps |
| Interface | interface.ti.com | Energy | www.ti.com/energy |
| Logic | logic.ti.com | Industrial | www.ti.com/industrial |
| Power Mgmt | power.ti.com | Medical | www.ti.com/medical |
| Microcontrollers | microcontroller.ti.com | Security | www.ti.com/security |
| RFID | www.ti-rfid.com | Space, Avionics & Defense | www.ti.com/space-avionics-defense |
| RF/IF and ZigBee® Solutions | www.ti.com/lprf | Video and Imaging | www.ti.com/video |
| | | Wireless | www.ti.com/wireless-apps |

Mailing Address: Texas Instruments, Post Office Box 655303, Dallas, Texas 75265
Copyright © 2010, Texas Instruments Incorporated