

LM118, LM218, LM318

FAST GENERAL-PURPOSE OPERATIONAL AMPLIFIERS

The LM118 and LM218 are obsolete and are no longer supplied.

SLOS063B – JUNE 1976 – REVISED DECEMBER 2002

- Small Signal Bandwidth . . . 15 MHz Typ
- Slew Rate . . . 50 V/μs Min
- Bias Current . . . 250 nA Max (LM118, LM218)
- Supply Voltage Range . . . ±5 V to ±20 V
- Internal Frequency Compensation
- Input and Output Overload Protection
- Same Pin Assignments as General-Purpose Operational Amplifiers

description/ordering information

The LM118, LM218, and LM318 are precision, fast operational amplifiers designed for applications requiring wide bandwidth and high slew rate. They feature a factor-of-ten increase in speed over general-purpose devices without sacrificing dc performance.

These operational amplifiers have internal unity-gain frequency compensation. This considerably simplifies their application because no external components are necessary for operation. However, unlike most internally compensated amplifiers, external frequency compensation may be added for optimum performance. For inverting applications, feed-forward compensation boosts the slew rate to over 150 V/μs and almost double the bandwidth. Overcompensation can be used with the amplifier for greater stability when maximum bandwidth is not needed. Further, a single capacitor can be added to reduce the settling time for 0.1% error band to under 1 μs.

The high speed and fast settling time of these operational amplifiers make them useful in A/D converters, oscillators, active filters, sample-and-hold circuits, and general-purpose amplifiers.

LM118 . . . JG PACKAGE
LM218 . . . D OR P PACKAGE
LM318 . . . D, P, OR PS PACKAGE
(TOP VIEW)

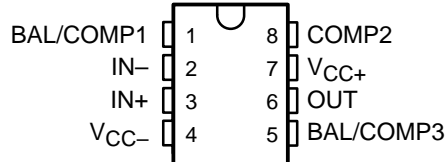

LM118 . . . FK PACKAGE
(TOP VIEW)

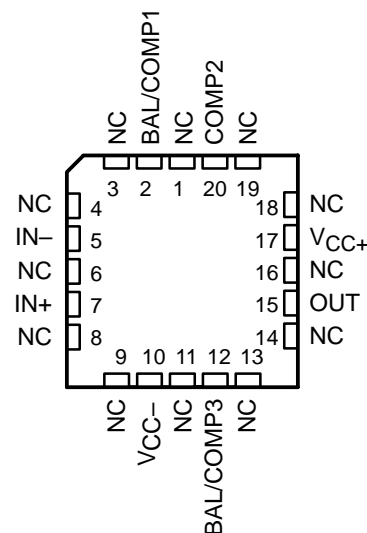

NC – No internal connection

ORDERING INFORMATION

TA	V _{IO} max AT 25°C	PACKAGE†		ORDERABLE PART NUMBER	TOP-SIDE MARKING
0°C to 70°C	10 mV	PDIP (P)	Tube of 50	LM318P	LM318P
		SOIC (D)	Tube of 75	LM318D	LM318
			Reel of 2500	LM318DR	
			SOP (PS)	Reel of 2000	LM318PSR

† Package drawings, standard packing quantities, thermal data, symbolization, and PCB design guidelines are available at www.ti.com/sc/package.

PRODUCTION DATA information is current as of publication date. Products conform to specifications per the terms of Texas Instruments standard warranty. Production processing does not necessarily include testing of all parameters.



POST OFFICE BOX 655303 • DALLAS, TEXAS 75265

Copyright © 2002, Texas Instruments Incorporated
On products compliant to MIL-PRF-38535, all parameters are tested unless otherwise noted. On all other products, production processing does not necessarily include testing of all parameters.

LM118, LM218, LM318 FAST GENERAL-PURPOSE OPERATIONAL AMPLIFIERS

The LM118 and LM218 are obsolete and are no longer supplied.

SLOS063B – JUNE 1976 – REVISED DECEMBER 2002

symbol

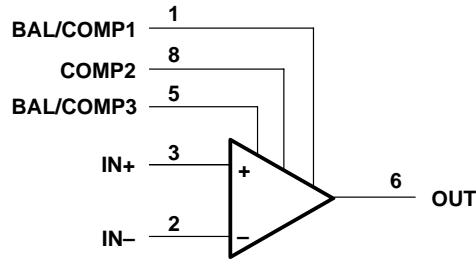

Pin numbers shown are for the D, JG, P, and PS packages.

schematic

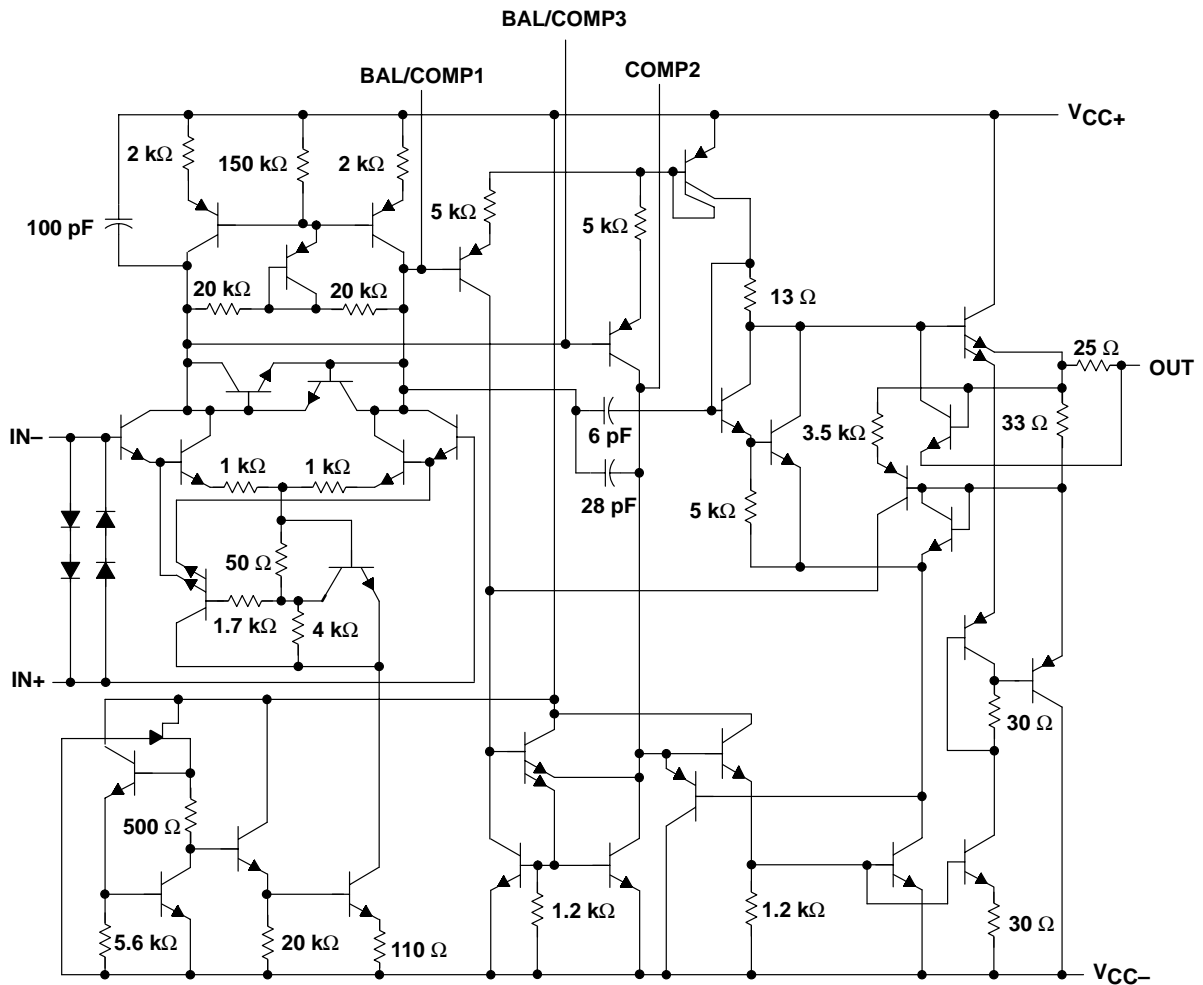

Component values shown are nominal.

The LM118 and LM218 are
obsolete and are no longer supplied.

SLOS063B – JUNE 1976 – REVISED DECEMBER 2002

absolute maximum ratings over operating free-air temperature range (unless otherwise noted)†

Supply voltage: V_{CC+} (see Note 1)	20 V
V_{CC-} (see Note 1)	-20 V
Input voltage, V_I (either input, see Notes 1 and 2)	± 15 V
Differential input current, V_{ID} (see Note 3)	± 10 V
Duration of output short circuit (see Note 4)	Unlimited
Operating virtual junction temperature, T_J	150°C
Package thermal impedance, θ_{JA} (see Notes 5 and 6): D package	97°C/W
P package	85°C/W
PS package	95°C/W
Package thermal impedance, θ_{JC} (see Notes 7 and 8): FK package	5.61°C/W
JG package	14.5°C/W
Case temperature for 60 seconds: FK package	260°C
Lead temperature 1,6 mm (1/16 inch) from case for 10 seconds: JG package	300°C
Lead temperature 1,6 mm (1/16 inch) from case for 60 seconds: D, P, PS, or PW package	260°C
Storage temperature range, T_{stg}	-65°C to 150°C

† Stresses beyond those listed under "absolute maximum ratings" may cause permanent damage to the device. These are stress ratings only, and functional operation of the device at these or any other conditions beyond those indicated under "recommended operating conditions" is not implied. Exposure to absolute-maximum-rated conditions for extended periods may affect device reliability.

- NOTES:
- All voltage values, unless otherwise noted, are with respect to the midpoint between V_{CC+} and V_{CC-} .
 - The magnitude of the input voltage must never exceed the magnitude of the supply voltage or 15 V, whichever is less.
 - The inputs are shunted with two opposite-facing base-emitter diodes for overvoltage protection. Therefore, excessive current flows if a different input voltage in excess of approximately 1 V is applied between the inputs unless some limiting resistance is used.
 - The output can be shorted to ground or either power supply. For the LM118 and LM218 only, the unlimited duration of the short circuit applies at (or below) 85°C case temperature or 75°C free-air temperature.
 - Maximum power dissipation is a function of $T_J(\max)$, θ_{JA} , and T_A . The maximum allowable power dissipation at any allowable ambient temperature is $P_D = (T_J(\max) - T_A)/\theta_{JA}$. Operating at the absolute maximum T_J of 150°C can affect reliability.
 - The package thermal impedance is calculated in accordance with JESD 51-7.
 - Maximum power dissipation is a function of $T_J(\max)$, θ_{JC} , and T_C . The maximum allowable power dissipation at any allowable ambient temperature is $P_D = (T_J(\max) - T_C)/\theta_{JC}$. Operating at the absolute maximum T_J of 150°C can affect reliability.
 - The package thermal impedance is calculated in accordance with MIL-STD-883.

LM118, LM218, LM318 FAST GENERAL-PURPOSE OPERATIONAL AMPLIFIERS

The LM118 and LM218 are obsolete and are no longer supplied.

SLOS063B – JUNE 1976 – REVISED DECEMBER 2002

electrical characteristics at specified free-air temperature (see Note 5)

PARAMETER	TEST CONDITIONS†	T _A ‡	LM118, LM218			LM318			UNIT
			MIN	TYP	MAX	MIN	TYP	MAX	
V _{IO} Input offset voltage	V _O = 0	25°C	2	4		4	10	mV	
		Full range			6		15		
I _{IO} Input offset current	V _O = 0	25°C	6	50		30	200	nA	
		Full range			100		300		
I _{IB} Input bias current	V _O = 0	25°C	120	250		150	500	nA	
		Full range			500		750		
V _{ICR} Common-mode input voltage range	V _{CC±} = ±15 V	Full range	±11.5			±11.5			V
V _{OM} Maximum peak output voltage swing	V _{CC±} = ±15 V, R _L = 2 kΩ	Full range	±12	±13		±12	±13	V	
A _{VD} Large-signal differential voltage amplification	V _{CC±} = ±15 V, V _O = ±10 V, R _L ≥ 2 kΩ	25°C	50	200		25	200	V/mV	
		Full range	25			20			
B ₁ Unity-gain bandwidth	V _{CC±} = ±15 V	25°C		15		15		MHz	
r _i Input resistance		25°C	1*	3		0.5	3	MΩ	
CMRR Common-mode rejection ratio	V _{IC} = V _{ICRmin}	Full range	80	100		70	100	dB	
k _{SVR} Supply-voltage rejection ratio (ΔV _{CC} /ΔV _{IO})		Full range	70	80		65	80	dB	
I _{CC} Supply current	V _O = 0, No load	25°C		5	8		5	10	mA

* On products compliant to MIL-STD-883, Class B, this parameter is not production tested.

† All characteristics are measured under open-loop conditions with common-mode input voltage, unless otherwise specified.

‡ Full range for LM118 is -55°C to 125°C, full range for LM218 is -25°C to 85°C, and full range for LM318 is 0°C to 70°C.

NOTE 9: Unless otherwise noted, V_{CC} = ±5 V to ±20 V. All typical values are at V_{CC±} = ±15 V and T_A = 25°C.

operating characteristics, V_{CC±} = ±15 V, T_A = 25°C

PARAMETER	TEST CONDITIONS	MIN	TYP	MAX	UNIT
SR Slew rate at unity gain	ΔV _I = 10 V, C _L = 100 pF, See Figure 1	50*	70		V/μs

* On products compliant to MIL-STD-883, Class B, this parameter is not production tested.

PARAMETER MEASUREMENT INFORMATION

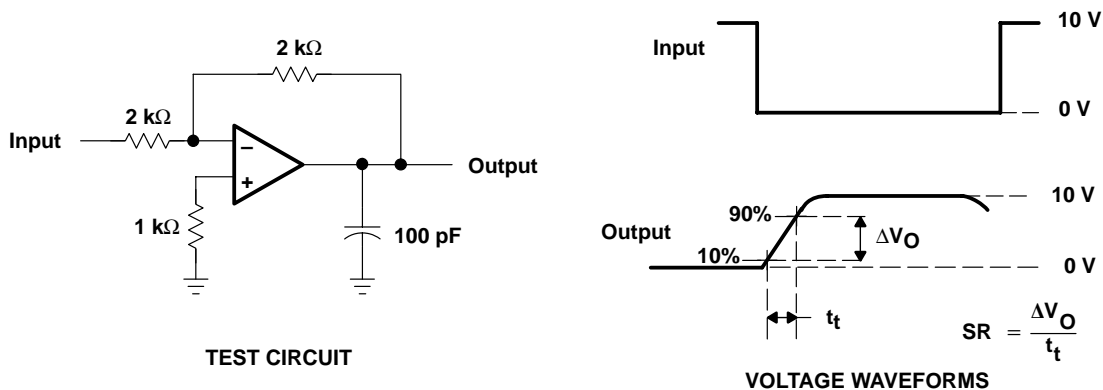
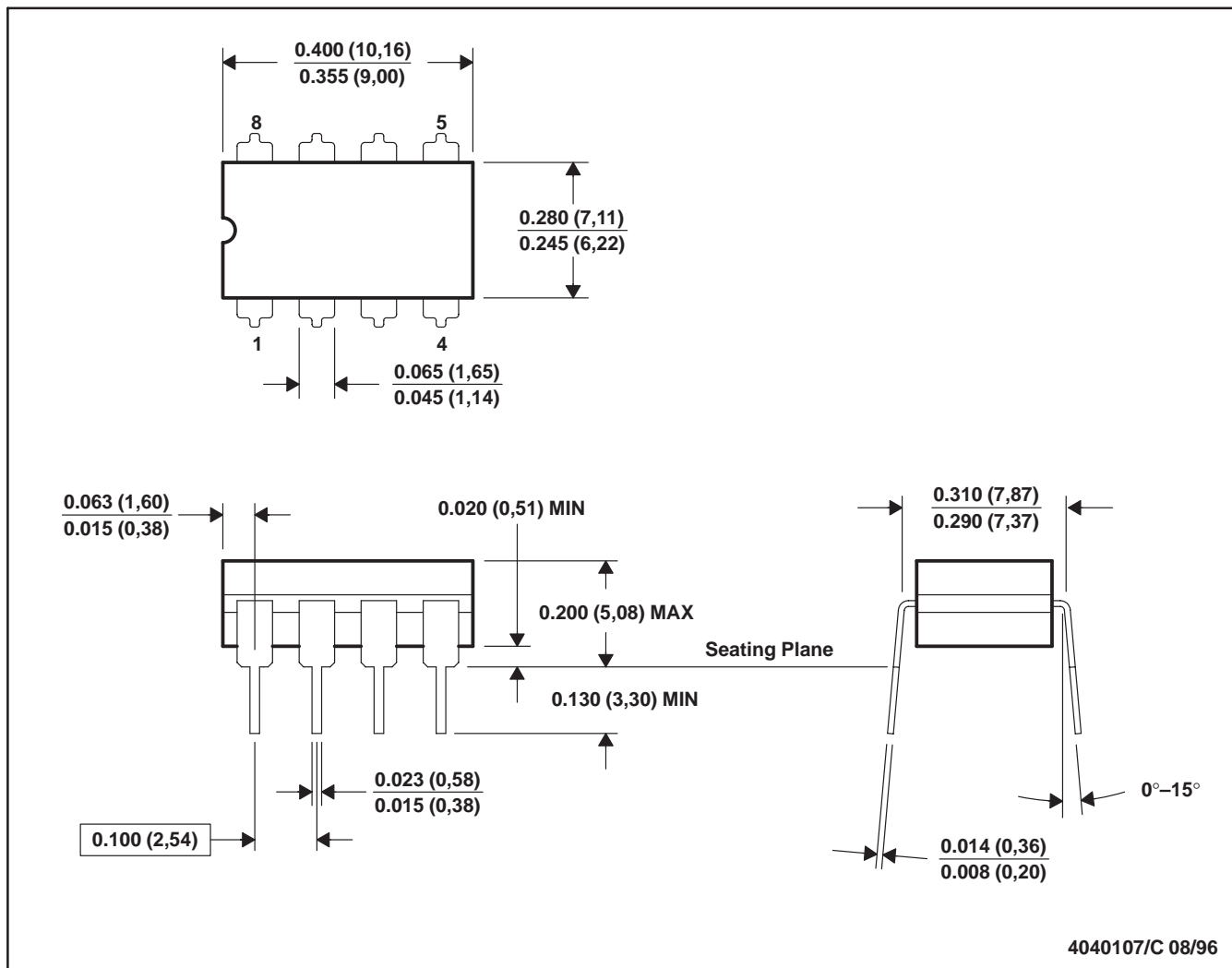

Figure 1. Slew Rate

JG (R-GDIP-T8)

CERAMIC DUAL-IN-LINE



- NOTES: A. All linear dimensions are in inches (millimeters).
 B. This drawing is subject to change without notice.
 C. This package can be hermetically sealed with a ceramic lid using glass frit.
 D. Index point is provided on cap for terminal identification.
 E. Falls within MIL STD 1835 GDIP1-T8

FK (S-CQCC-N**)

LEADLESS CERAMIC CHIP CARRIER

28 TERMINAL SHOWN

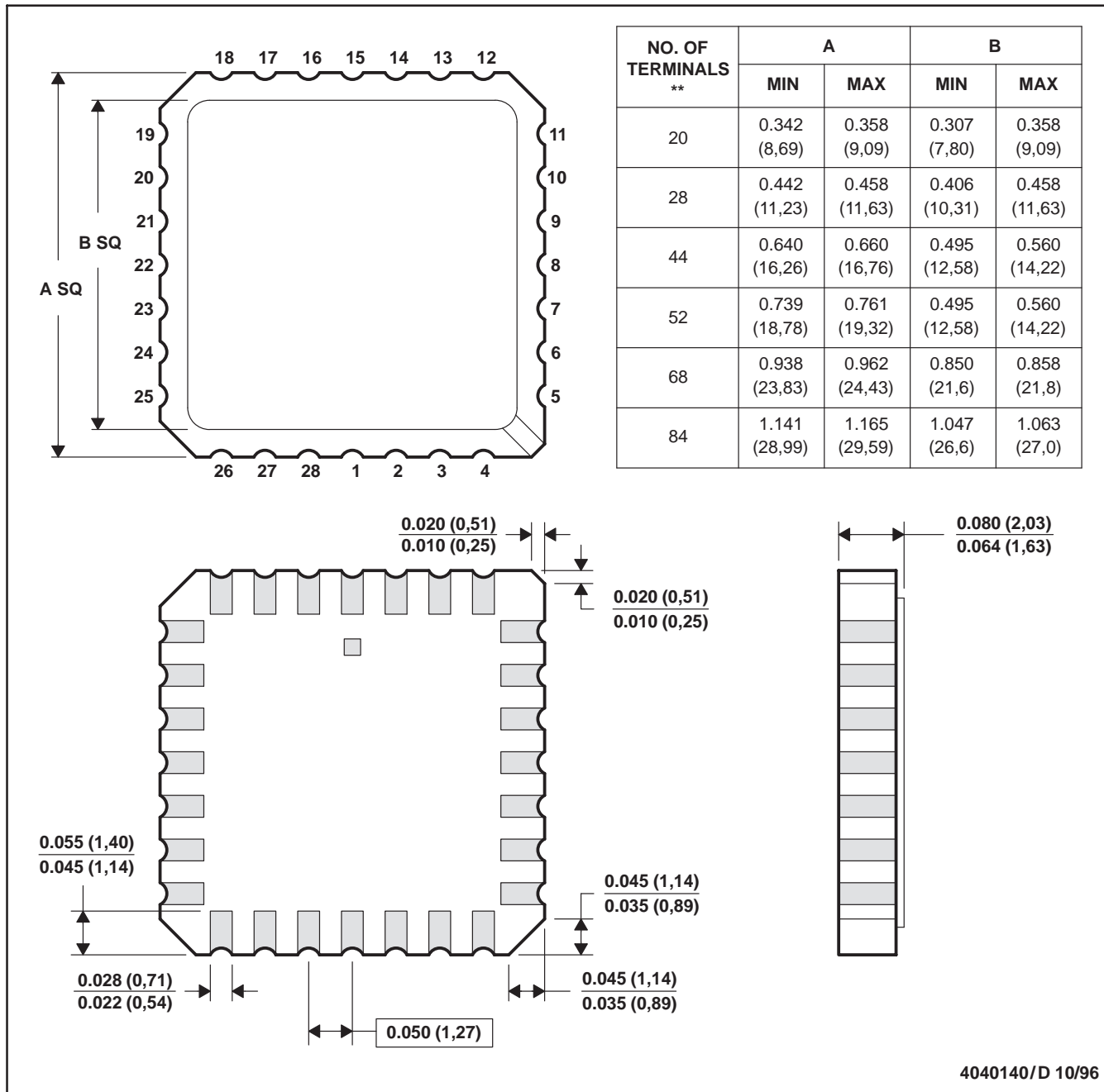

- NOTES:
- A. All linear dimensions are in inches (millimeters).
 - B. This drawing is subject to change without notice.
 - C. This package can be hermetically sealed with a metal lid.
 - D. The terminals are gold plated.
 - E. Falls within JEDEC MS-004

P (R-PDIP-T8)

PLASTIC DUAL-IN-LINE

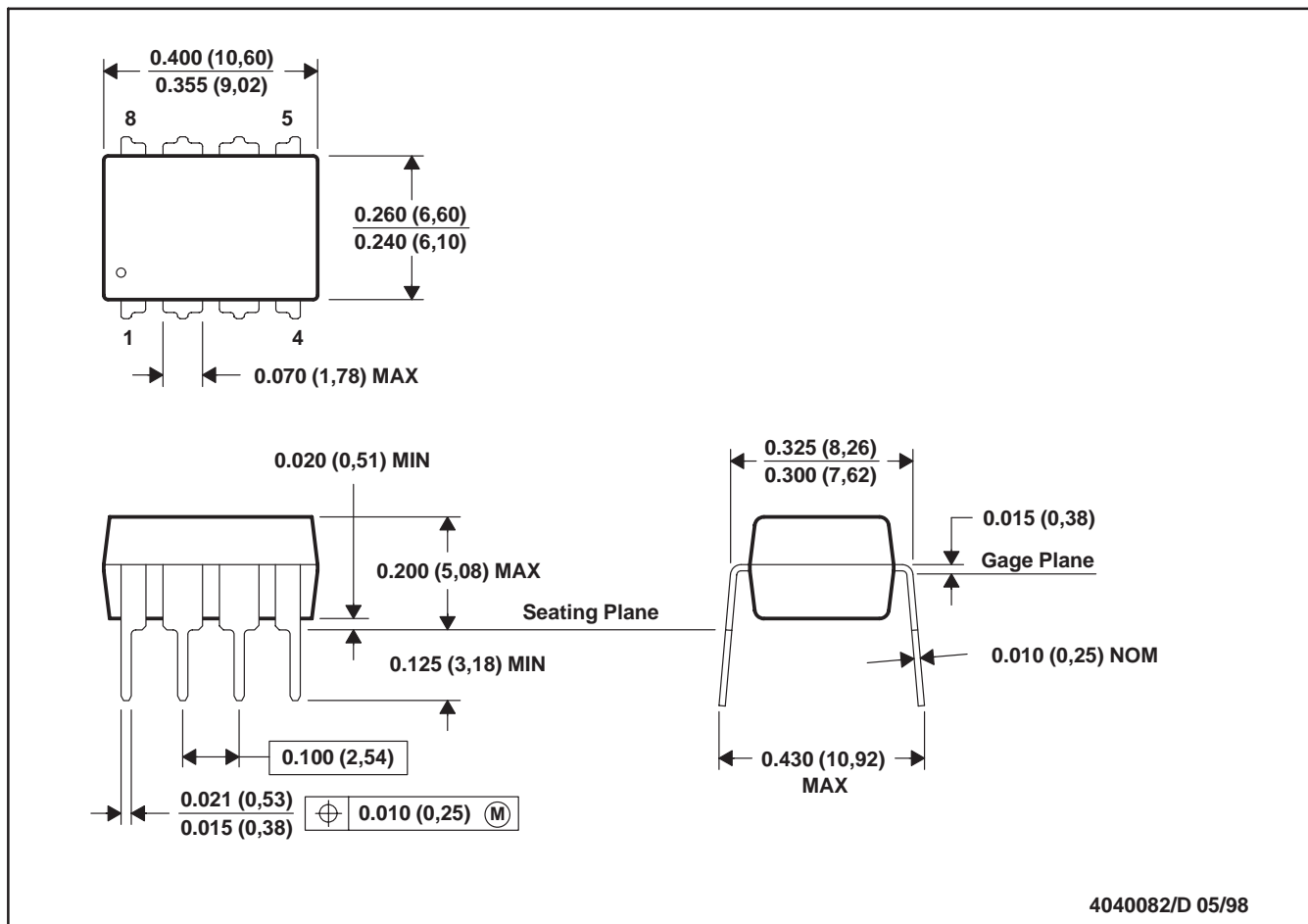

- NOTES: A. All linear dimensions are in inches (millimeters).
 B. This drawing is subject to change without notice.
 C. Falls within JEDEC MS-001

For the latest package information, go to http://www.ti.com/sc/docs/package/pkg_info.htm

D (R-PDSO-G**)

PLASTIC SMALL-OUTLINE PACKAGE

8 PINS SHOWN

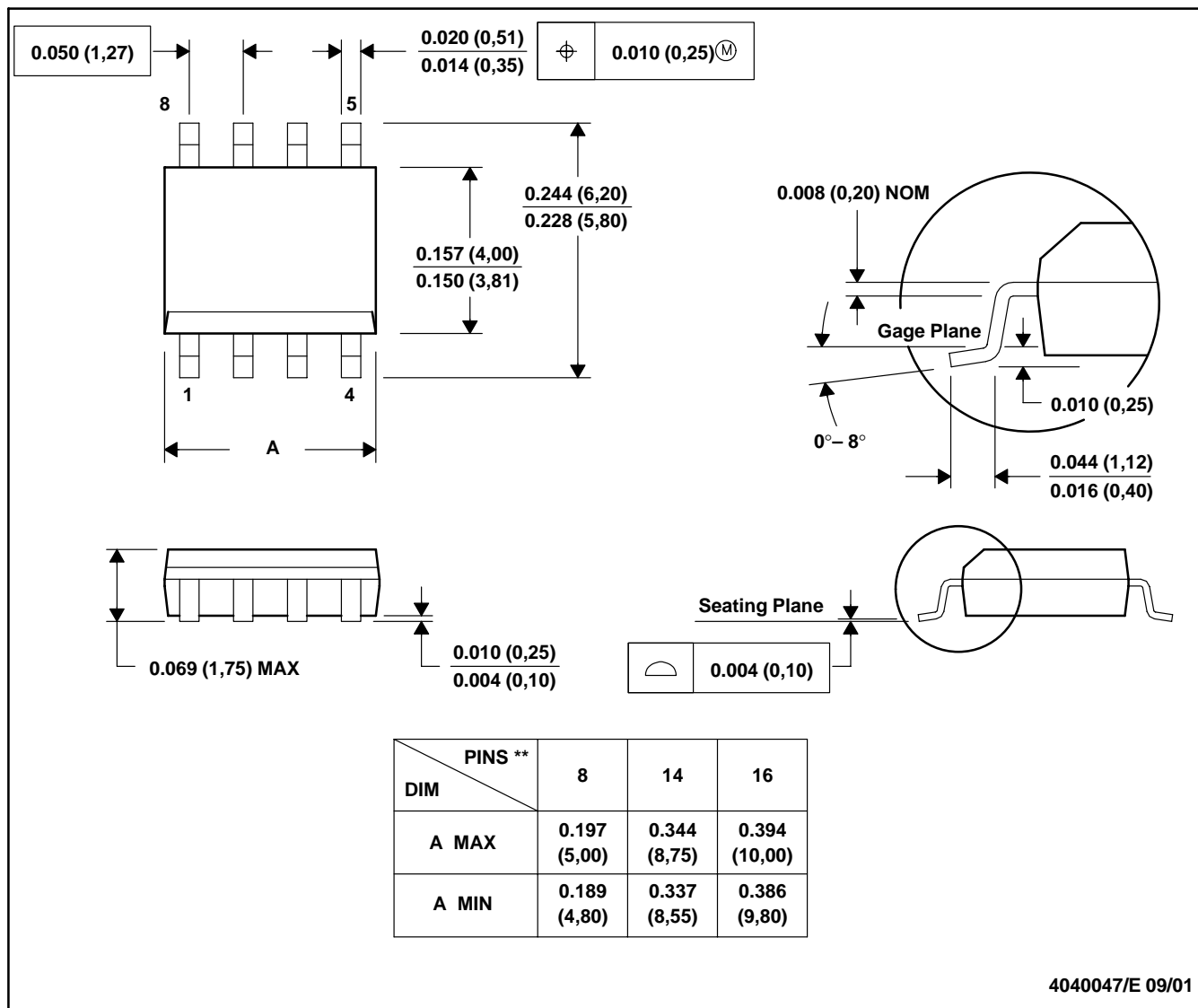

4040047/E 09/01

- NOTES: A. All linear dimensions are in inches (millimeters).
 B. This drawing is subject to change without notice.
 C. Body dimensions do not include mold flash or protrusion, not to exceed 0.006 (0,15).
 D. Falls within JEDEC MS-012

PS (R-PDSO-G8)

PLASTIC SMALL-OUTLINE PACKAGE

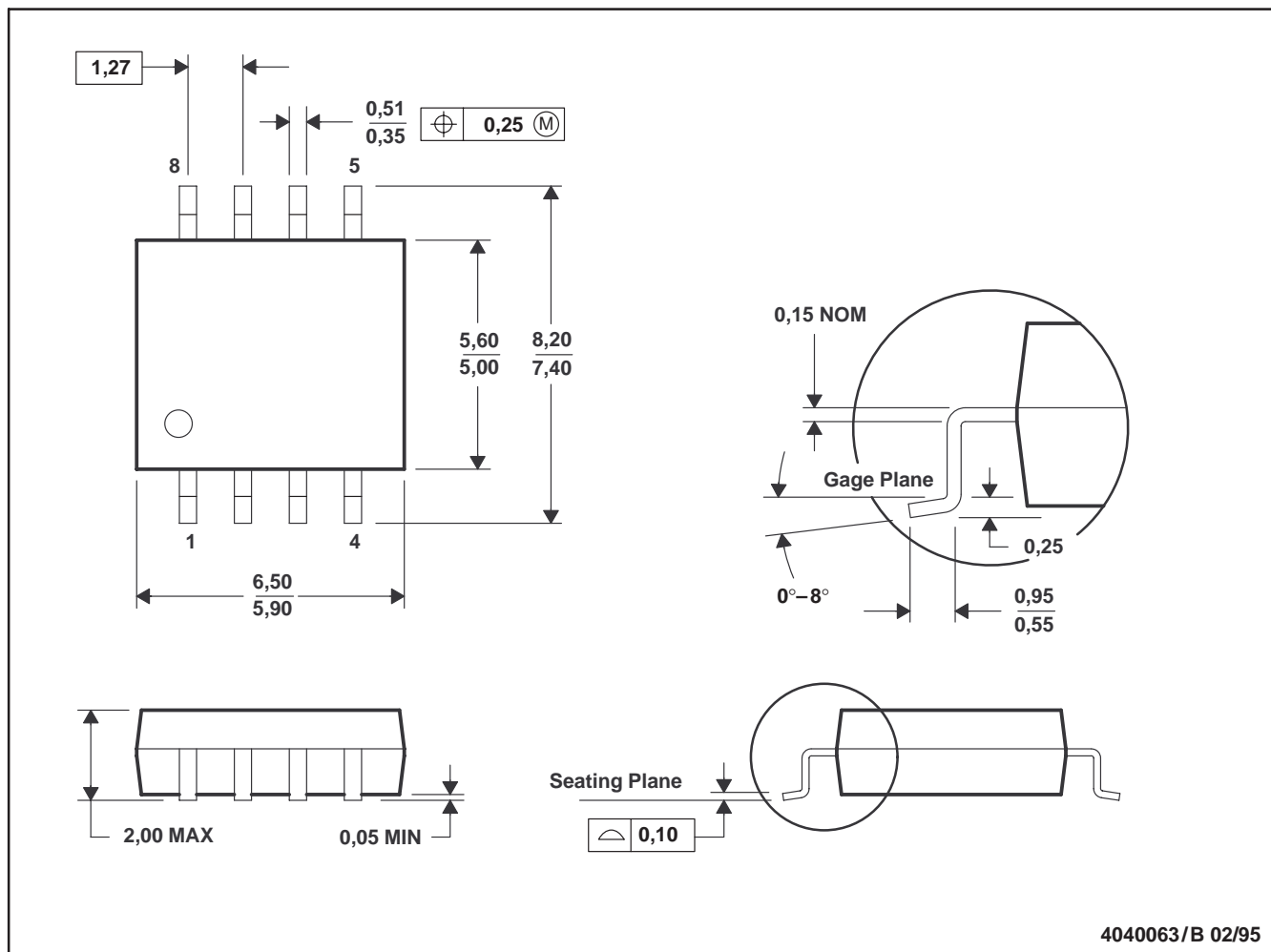

- NOTES: A. All linear dimensions are in millimeters.
 B. This drawing is subject to change without notice.
 C. Body dimensions do not include mold flash or protrusion, not to exceed 0,15.

IMPORTANT NOTICE

Texas Instruments Incorporated and its subsidiaries (TI) reserve the right to make corrections, modifications, enhancements, improvements, and other changes to its products and services at any time and to discontinue any product or service without notice. Customers should obtain the latest relevant information before placing orders and should verify that such information is current and complete. All products are sold subject to TI's terms and conditions of sale supplied at the time of order acknowledgment.

TI warrants performance of its hardware products to the specifications applicable at the time of sale in accordance with TI's standard warranty. Testing and other quality control techniques are used to the extent TI deems necessary to support this warranty. Except where mandated by government requirements, testing of all parameters of each product is not necessarily performed.

TI assumes no liability for applications assistance or customer product design. Customers are responsible for their products and applications using TI components. To minimize the risks associated with customer products and applications, customers should provide adequate design and operating safeguards.

TI does not warrant or represent that any license, either express or implied, is granted under any TI patent right, copyright, mask work right, or other TI intellectual property right relating to any combination, machine, or process in which TI products or services are used. Information published by TI regarding third-party products or services does not constitute a license from TI to use such products or services or a warranty or endorsement thereof. Use of such information may require a license from a third party under the patents or other intellectual property of the third party, or a license from TI under the patents or other intellectual property of TI.

Reproduction of information in TI data books or data sheets is permissible only if reproduction is without alteration and is accompanied by all associated warranties, conditions, limitations, and notices. Reproduction of this information with alteration is an unfair and deceptive business practice. TI is not responsible or liable for such altered documentation.

Resale of TI products or services with statements different from or beyond the parameters stated by TI for that product or service voids all express and any implied warranties for the associated TI product or service and is an unfair and deceptive business practice. TI is not responsible or liable for any such statements.

Mailing Address:

Texas Instruments
Post Office Box 655303
Dallas, Texas 75265