

## LM111-N/LM211-N/LM311-N Voltage Comparator

 Check for Samples: [LM111-N](#), [LM211-N](#), [LM311-N](#)

### FEATURES

- Operates From Single 5V Supply
- Input Current: 150 nA Max. Over Temperature
- Offset Current: 20 nA Max. Over Temperature
- Differential Input Voltage Range:  $\pm 30V$
- Power Consumption: 135 mW at  $\pm 15V$

### DESCRIPTION

The LM111-N, LM211-N and LM311-N are voltage comparators that have input currents nearly a thousand times lower than devices like the LM106 or LM710. They are also designed to operate over a wider range of supply voltages: from standard  $\pm 15V$  op amp supplies down to the single 5V supply used for IC logic. Their output is compatible with RTL, DTL and TTL as well as MOS circuits. Further, they can drive lamps or relays, switching voltages up to 50V at currents as high as 50 mA.

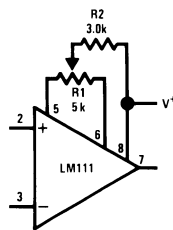
### Typical Applications

Both the inputs and the outputs of the LM111-N, LM211-N or the LM311-N can be isolated from system ground, and the output can drive loads referred to ground, the positive supply or the negative supply. Offset balancing and strobe capability are provided and outputs can be wire OR'ed. Although slower than the LM106 and LM710 (200 ns response time vs 40 ns) the devices are also much less prone to spurious oscillations. The LM111-N has the same pin configuration as the LM106 and LM710.

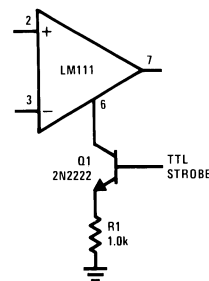
The LM211-N is identical to the LM111-N, except that its performance is specified over a  $-25^{\circ}C$  to  $+85^{\circ}C$  temperature range instead of  $-55^{\circ}C$  to  $+125^{\circ}C$ . The LM311-N has a temperature range of  $0^{\circ}C$  to  $+70^{\circ}C$ .

### NOTE

Pin connections shown in [Schematic Diagram](#) and [Typical Applications](#) are for the LMC TO-99 package.



**Figure 1. Offset Balancing**



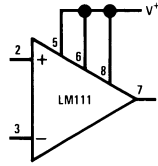
**Do Not** Ground Strobe Pin. Output is turned off when current is pulled from Strobe Pin.

**Figure 2. Strobing**



Please be aware that an important notice concerning availability, standard warranty, and use in critical applications of Texas Instruments semiconductor products and disclaimers thereto appears at the end of this data sheet.

All trademarks are the property of their respective owners.



Increases typical common mode slew from 7.0V/μs to 18V/μs.

Figure 3. Increasing Input Stage Current

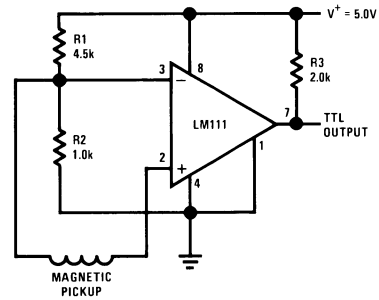


Figure 4. Detector for Magnetic Transducer

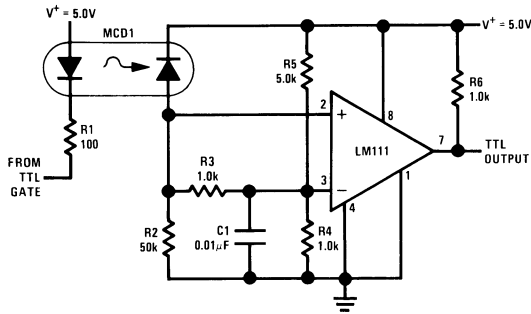
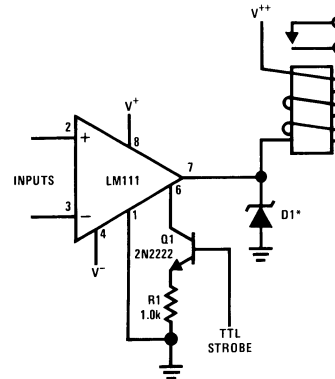


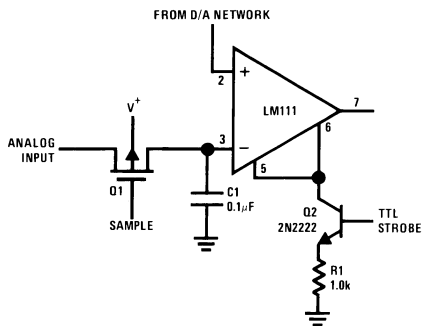
Figure 5. Digital Transmission Isolator



\*Absorbs inductive kickback of relay and protects IC from severe voltage transients on V<sup>++</sup> line.

**Do Not** Ground Strobe Pin.

Figure 6. Relay Driver with Strobe

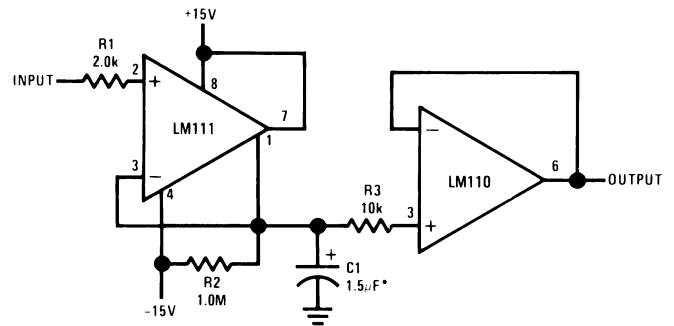


**Do Not** Ground Strobe Pin.

Typical input current is 50 pA with inputs strobed off.

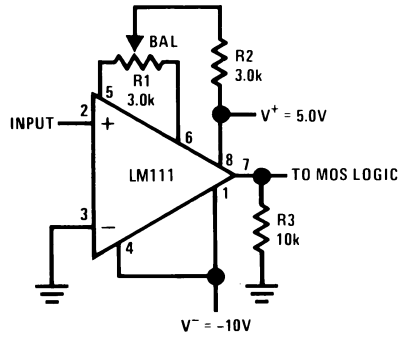
Pin connections shown in [Schematic Diagram](#) and [Typical Applications](#) are for the LMC TO-99 package.

Figure 7. Strobing off Both Input and Output Stages



\*Solid tantalum

Figure 8. Positive Peak Detector



**Figure 9. Zero Crossing Detector Driving MOS Logic**



These devices have limited built-in ESD protection. The leads should be shorted together or the device placed in conductive foam during storage or handling to prevent electrostatic damage to the MOS gates.

**Absolute Maximum Ratings for the LM111-N/LM211-N<sup>(1)(2)</sup>**

Total Supply Voltage ( $V_{84}$ )		36V	
Output to Negative Supply Voltage ( $V_{74}$ )		50V	
Ground to Negative Supply Voltage ( $V_{14}$ )		30V	
Differential Input Voltage		$\pm 30V$	
Input Voltage <sup>(3)</sup>		$\pm 15V$	
Output Short Circuit Duration		10 sec	
Operating Temperature Range		LM111-N	-55°C to 125°C
		LM211-N	-25°C to 85°C
Lead Temperature (Soldering, 10 sec)		260°C	
Voltage at Strobe Pin		$V^+ - 5V$	
Soldering Information	Dual-In-Line Package	Soldering (10 seconds)	260°C
	Small Outline Package	Vapor Phase (60 seconds)	215°C
		Infrared (15 seconds)	220°C
ESD Rating <sup>(4)</sup>		300V	

- (1) Refer to RETS111X for the LM111H, LM111J and LM111J-8 military specifications.
- (2) If Military/Aerospace specified devices are required, please contact the Texas Instruments Sales Office/ Distributors for availability and specifications.
- (3) This rating applies for  $\pm 15V$  supplies. The positive input voltage limit is 30V above the negative supply. The negative input voltage limit is equal to the negative supply voltage or 30V below the positive supply, whichever is less.
- (4) Human body model, 1.5 k $\Omega$  in series with 100 pF.

**Electrical Characteristics<sup>(1)</sup> for the LM111-N and LM211-N**

Parameter	Conditions	Min	Typ	Max	Units
Input Offset Voltage <sup>(2)</sup>	$T_A = 25^\circ C$ , $R_S \leq 50k$		0.7	3.0	mV
Input Offset Current	$T_A = 25^\circ C$		4.0	10	nA
Input Bias Current	$T_A = 25^\circ C$		60	100	nA
Voltage Gain	$T_A = 25^\circ C$	40	200		V/mV
Response Time <sup>(3)</sup>	$T_A = 25^\circ C$		200		ns
Saturation Voltage	$V_{IN} \leq -5$ mV, $I_{OUT} = 50$ mA $T_A = 25^\circ C$		0.75	1.5	V
Strobe ON Current <sup>(4)</sup>	$T_A = 25^\circ C$		2.0	5.0	mA
Output Leakage Current	$V_{IN} \geq 5$ mV, $V_{OUT} = 35V$ , $T_A = 25^\circ C$ , $I_{STROBE} = 3$ mA		0.2	10	nA
Input Offset Voltage <sup>(2)</sup>	$R_S \leq 50$ k			4.0	mV
Input Offset Current <sup>(2)</sup>				20	nA
Input Bias Current				150	nA
Input Voltage Range	$V^+ = 15V$ , $V^- = -15V$ , Pin 7 Pull-Up May Go To 5V	-14.5	13.8-14.7	13.0	V
Saturation Voltage	$V^+ \geq 4.5V$ , $V^- = 0$ , $V_{IN} \leq -6$ mV, $I_{OUT} \leq 8$ mA		0.23	0.4	V
Output Leakage Current	$V_{IN} \geq 5$ mV, $V_{OUT} = 35V$		0.1	0.5	$\mu A$
Positive Supply Current	$T_A = 25^\circ C$		5.1	6.0	mA
Negative Supply Current	$T_A = 25^\circ C$		4.1	5.0	mA

- (1) These specifications apply for  $V_S = \pm 15V$  and Ground pin at ground, and  $-55^\circ C \leq T_A \leq +125^\circ C$ , unless otherwise stated. With the LM211-N, however, all temperature specifications are limited to  $-25^\circ C \leq T_A \leq +85^\circ C$ . The offset voltage, offset current and bias current specifications apply for any supply voltage from a single 5V supply up to  $\pm 15V$  supplies.
- (2) The offset voltages and offset currents given are the maximum values required to drive the output within a volt of either supply with a 1 mA load. Thus, these parameters define an error band and take into account the worst-case effects of voltage gain and  $R_S$ .
- (3) The response time specified (see definitions) is for a 100 mV input step with 5 mV overdrive.
- (4) This specification gives the range of current which must be drawn from the strobe pin to ensure the output is properly disabled. Do not short the strobe pin to ground; it should be current driven at 3 to 5 mA.

**Absolute Maximum Ratings for the LM311-N<sup>(1)(2)</sup>**

Total Supply Voltage ( $V_{84}$ )		36V	
Output to Negative Supply Voltage ( $V_{74}$ )		40V	
Ground to Negative Supply Voltage ( $V_{14}$ )		30V	
Differential Input Voltage		$\pm 30V$	
Input Voltage <sup>(3)</sup>		$\pm 15V$	
Power Dissipation <sup>(4)</sup>		500 mW	
ESD Rating <sup>(5)</sup>		300V	
Output Short Circuit Duration		10 sec	
Operating Temperature Range		0° to 70°C	
Storage Temperature Range		-65°C to 150°C	
Lead Temperature (soldering, 10 sec)		260°C	
Voltage at Strobe Pin		$V^+ - 5V$	
Soldering Information	Dual-In-Line Package	Soldering (10 seconds)	260°C
	Small Outline Package	Vapor Phase (60 seconds)	215°C
		Infrared (15 seconds)	220°C

- (1) "Absolute Maximum Ratings indicate limits beyond which damage to the device may occur. Operating Ratings indicate conditions for which the device is functional, but do not ensure specific performance limits."
- (2) If Military/Aerospace specified devices are required, please contact the Texas Instruments Sales Office/ Distributors for availability and specifications.
- (3) This rating applies for  $\pm 15V$  supplies. The positive input voltage limit is 30V above the negative supply. The negative input voltage limit is equal to the negative supply voltage or 30V below the positive supply, whichever is less.
- (4) The maximum junction temperature of the LM311-N is 110°C. For operating at elevated temperature, devices in the LMC package must be derated based on a thermal resistance of 165°C/W, junction to ambient, or 20°C/W, junction to case. The thermal resistance of the dual-in-line package is 100°C/W, junction to ambient.
- (5) Human body model, 1.5 k $\Omega$  in series with 100 pF.

**Electrical Characteristics<sup>(1)</sup> for the LM311-N**

Parameter	Conditions	Min	Typ	Max	Units
Input Offset Voltage <sup>(2)</sup>	$T_A = 25^\circ C, R_S \leq 50k$		2.0	7.5	mV
Input Offset Current <sup>(2)</sup>	$T_A = 25^\circ C$		6.0	50	nA
Input Bias Current	$T_A = 25^\circ C$		100	250	nA
Voltage Gain	$T_A = 25^\circ C$	40	200		V/mV
Response Time <sup>(3)</sup>	$T_A = 25^\circ C$		200		ns
Saturation Voltage	$V_{IN} \leq -10 mV, I_{OUT} = 50 mA, T_A = 25^\circ C$		0.75	1.5	V
Strobe ON Current <sup>(4)</sup>	$T_A = 25^\circ C$		2.0	5.0	mA
Output Leakage Current	$V_{IN} \geq 10 mV, V_{OUT} = 35V, T_A = 25^\circ C, I_{STROBE} = 3 mA, V^- = Pin 1 = -5V$		0.2	50	nA
Input Offset Voltage <sup>(2)</sup>	$R_S \leq 50K$			10	mV
Input Offset Current <sup>(2)</sup>				70	nA
Input Bias Current				300	nA
Input Voltage Range		-14.5	13.8, -14.7	13.0	V
Saturation Voltage	$V^+ \geq 4.5V, V^- = 0, V_{IN} \leq -10 mV, I_{OUT} \leq 8 mA$		0.23	0.4	V
Positive Supply Current	$T_A = 25^\circ C$		5.1	7.5	mA
Negative Supply Current	$T_A = 25^\circ C$		4.1	5.0	mA

- (1) These specifications apply for  $V_S = \pm 15V$  and Pin 1 at ground, and  $0^\circ C < T_A < +70^\circ C$ , unless otherwise specified. The offset voltage, offset current and bias current specifications apply for any supply voltage from a single 5V supply up to  $\pm 15V$  supplies.
- (2) The offset voltages and offset currents given are the maximum values required to drive the output within a volt of either supply with 1 mA load. Thus, these parameters define an error band and take into account the worst-case effects of voltage gain and  $R_S$ .
- (3) The response time specified (see definitions) is for a 100 mV input step with 5 mV overdrive.
- (4) This specification gives the range of current which must be drawn from the strobe pin to ensure the output is properly disabled. Do not short the strobe pin to ground; it should be current driven at 3 to 5 mA.

Typical Performance Characteristics LM111-N/LM211-N

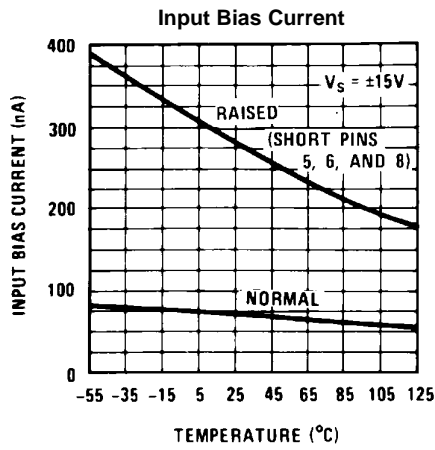


Figure 10.

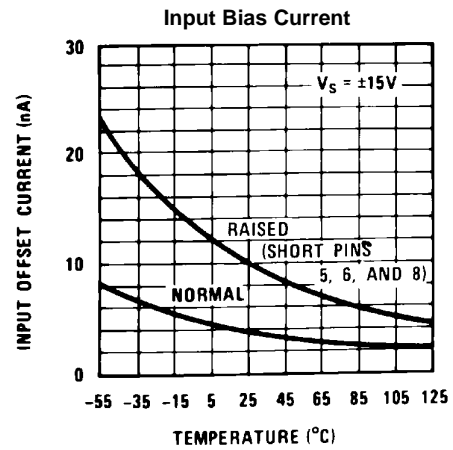


Figure 11.

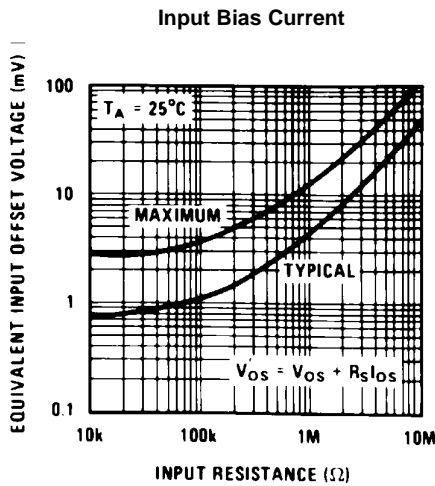


Figure 12.

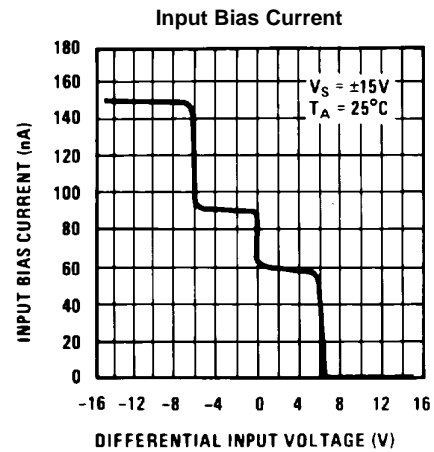


Figure 13.

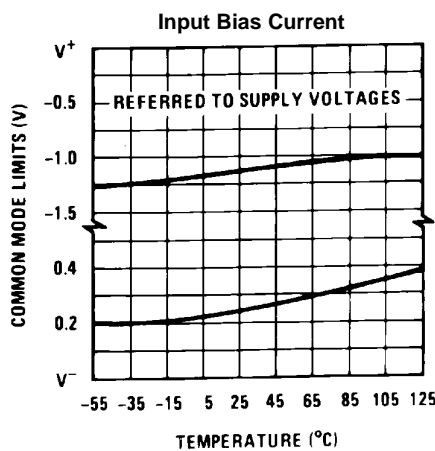


Figure 14.

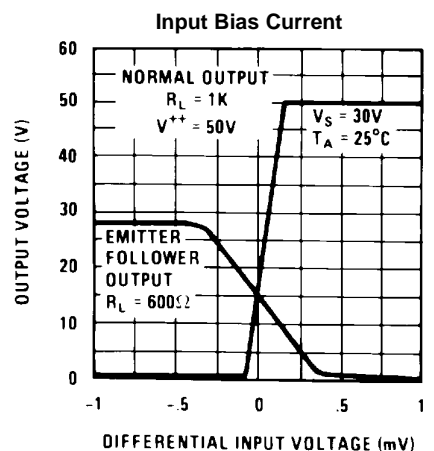


Figure 15.

Typical Performance Characteristics LM111-N/LM211-N (continued)

Input Bias Current  
Input Overdrives

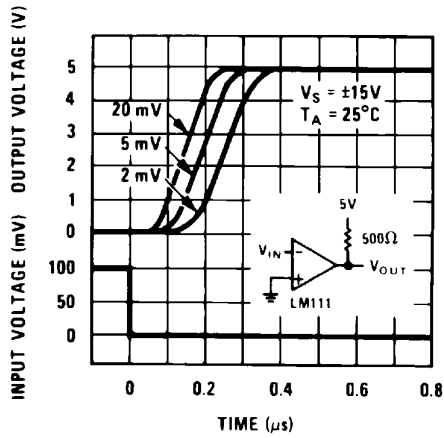


Figure 16.

Input Bias Current  
Input Overdrives

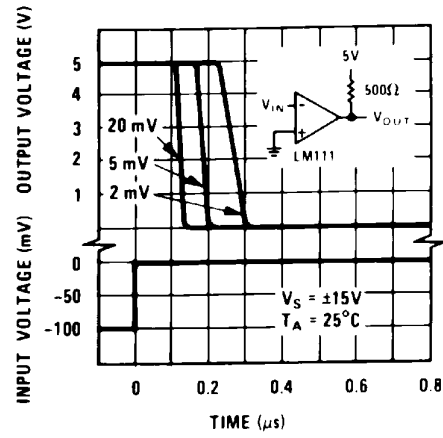


Figure 17.

Input Bias Current

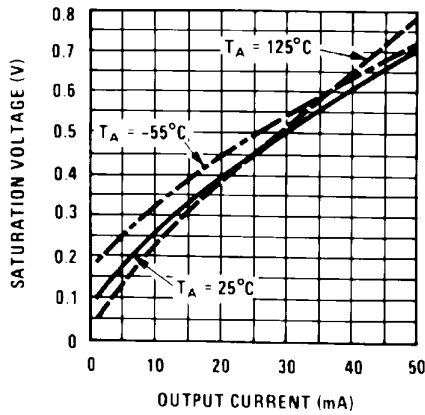


Figure 18.

Response Time for Various  
Input Overdrives

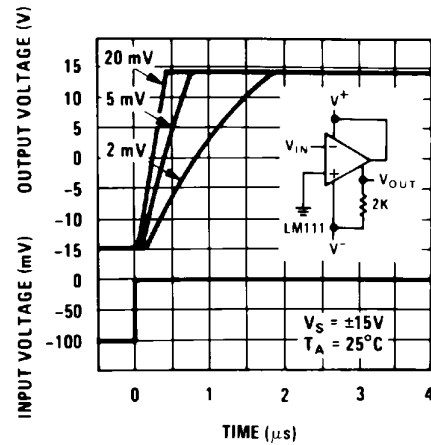


Figure 19.

Response Time for Various  
Input Overdrives

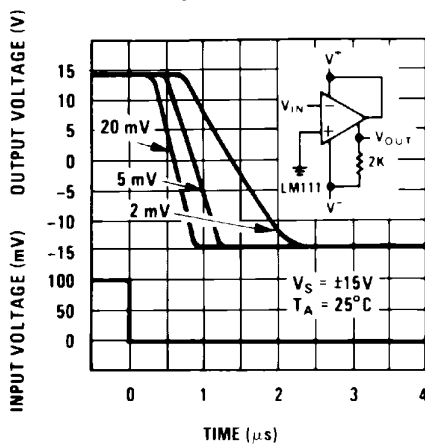


Figure 20.

Output Limiting Characteristics

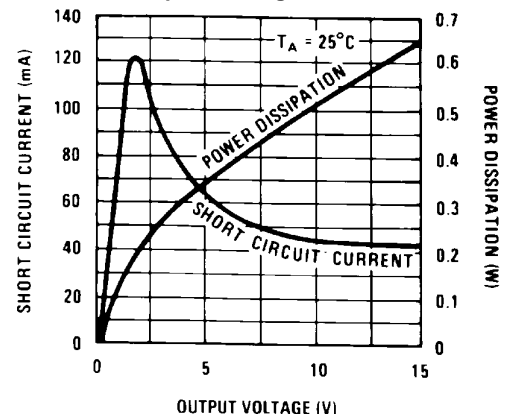
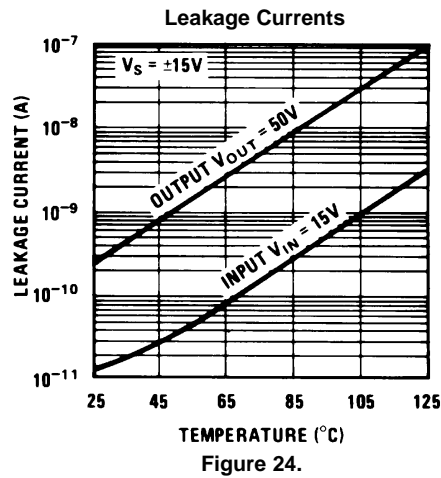
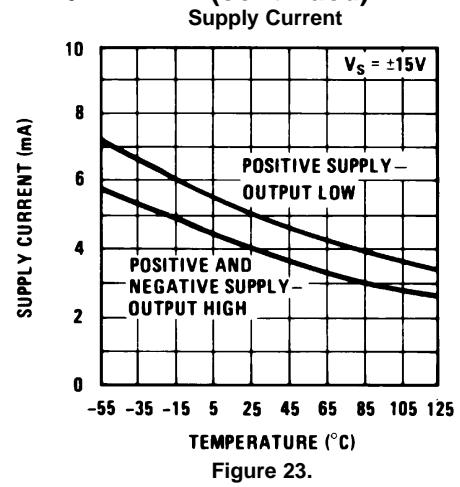
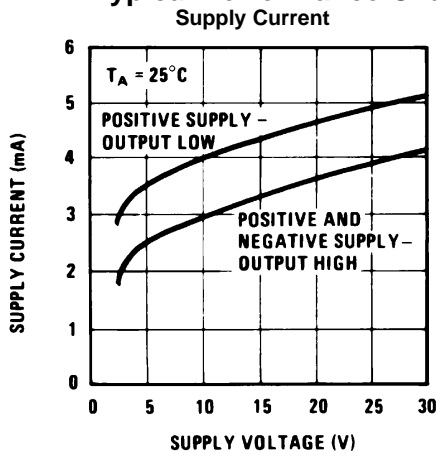


Figure 21.

**Typical Performance Characteristics LM111-N/LM211-N (continued)**



Typical Performance Characteristics LM311-N

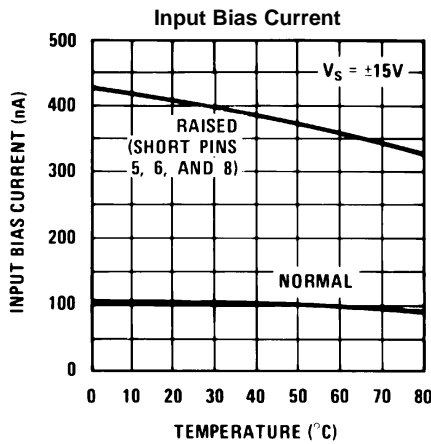


Figure 25.

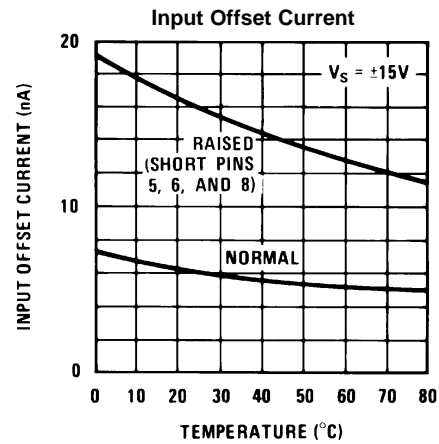


Figure 26.

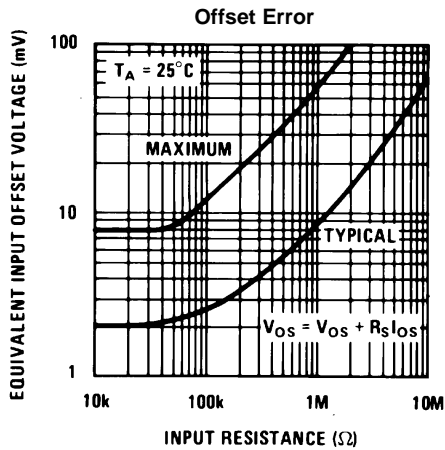


Figure 27.

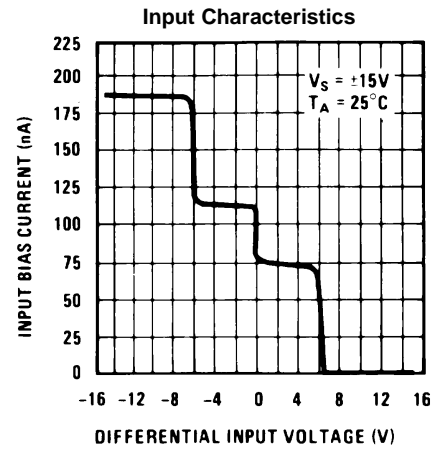


Figure 28.

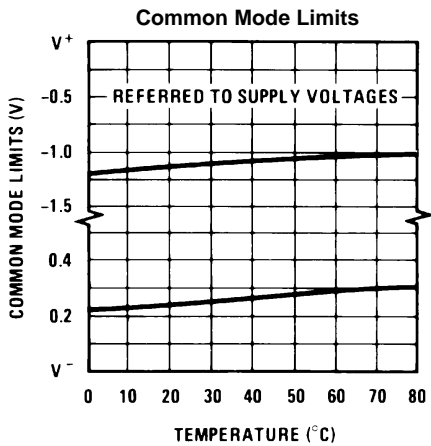


Figure 29.

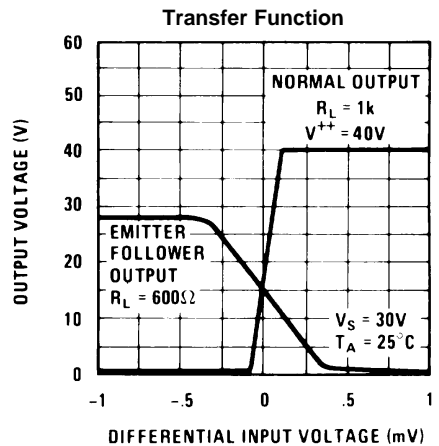


Figure 30.

**Typical Performance Characteristics LM311-N (continued)**  
 Response Time for Various Input Overdrives

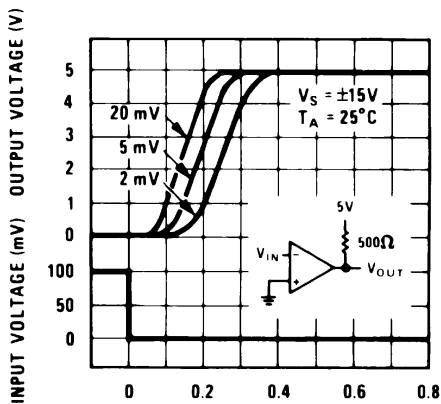


Figure 31.

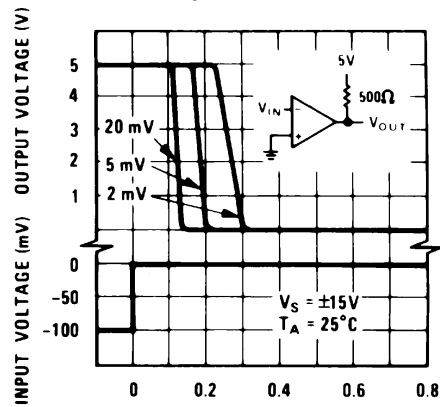


Figure 32.

Output Saturation Voltage

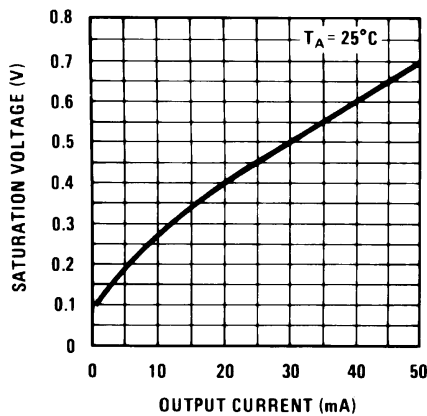


Figure 33.

Response Time for Various Input Overdrives

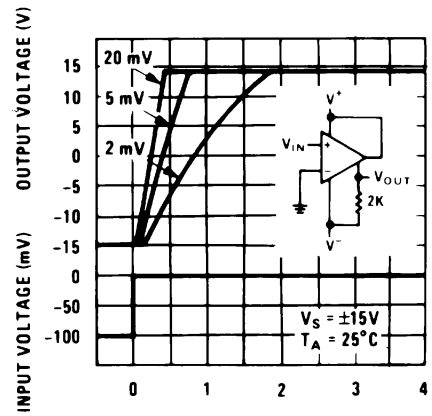


Figure 34.

Response Time for Various Input Overdrives

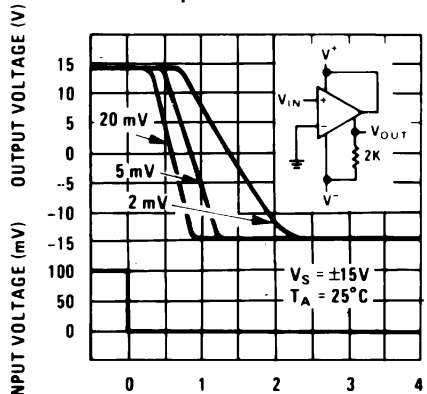


Figure 35.

Output Limiting Characteristics

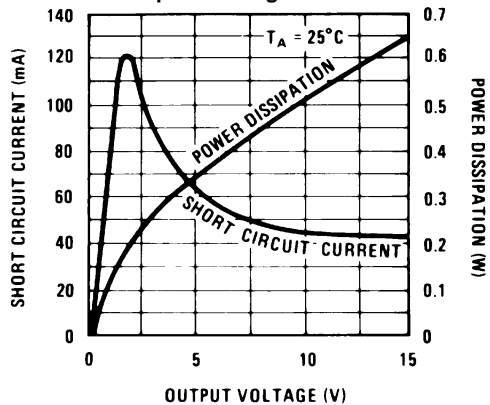
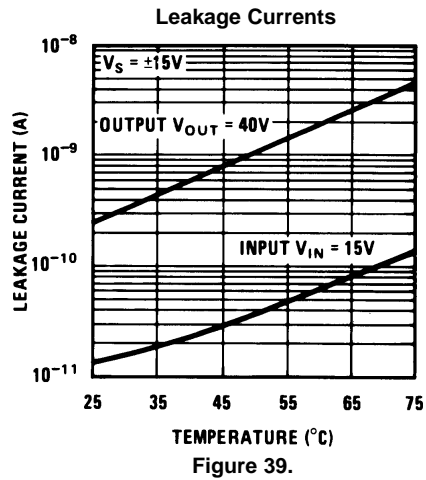
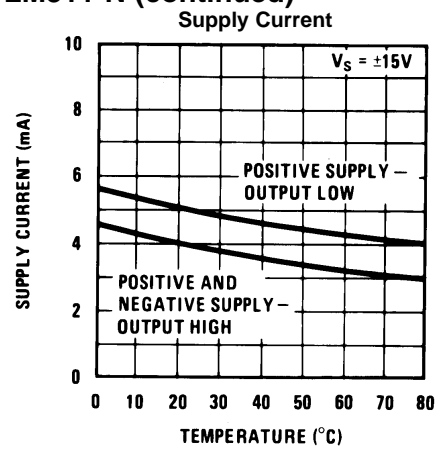
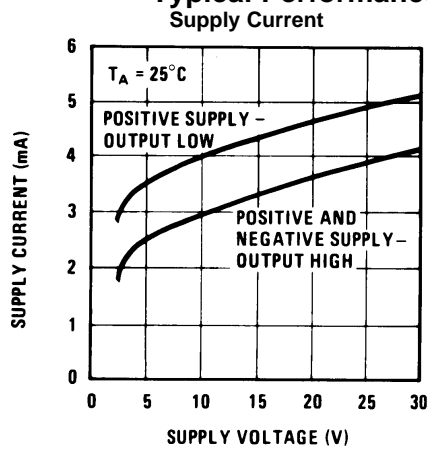


Figure 36.

Typical Performance Characteristics LM311-N (continued)



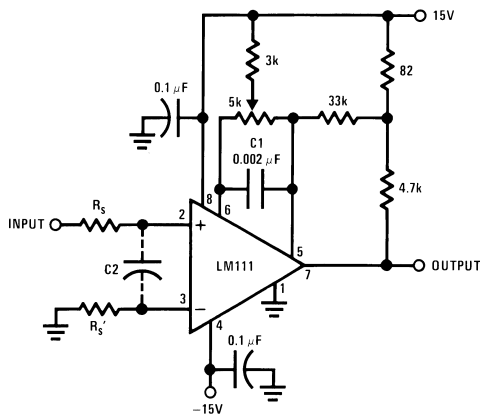
## APPLICATION HINTS

### CIRCUIT TECHNIQUES FOR AVOIDING OSCILLATIONS IN COMPARATOR APPLICATIONS

When a high-speed comparator such as the LM111-N is used with fast input signals and low source impedances, the output response will normally be fast and stable, assuming that the power supplies have been bypassed (with 0.1  $\mu\text{F}$  disc capacitors), and that the output signal is routed well away from the inputs (pins 2 and 3) and also away from pins 5 and 6.

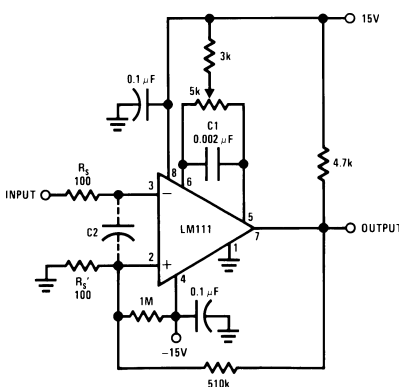
However, when the input signal is a voltage ramp or a slow sine wave, or if the signal source impedance is high (1  $\text{k}\Omega$  to 100  $\text{k}\Omega$ ), the comparator may burst into oscillation near the crossing-point. This is due to the high gain and wide bandwidth of comparators like the LM111-N. To avoid oscillation or instability in such a usage, several precautions are recommended, as shown in [Figure 40](#) below.

1. The trim pins (pins 5 and 6) act as unwanted auxiliary inputs. If these pins are not connected to a trim-pot, they should be shorted together. If they are connected to a trim-pot, a 0.01  $\mu\text{F}$  capacitor C1 between pins 5 and 6 will minimize the susceptibility to AC coupling. A smaller capacitor is used if pin 5 is used for positive feedback as in [Figure 40](#).
2. Certain sources will produce a cleaner comparator output waveform if a 100 pF to 1000 pF capacitor C2 is connected directly across the input pins.
3. When the signal source is applied through a resistive network,  $R_S$ , it is usually advantageous to choose an  $R_S'$  of substantially the same value, both for DC and for dynamic (AC) considerations. Carbon, tin-oxide, and metal-film resistors have all been used successfully in comparator input circuitry. Inductive wirewound resistors are not suitable.
4. When comparator circuits use input resistors (eg. summing resistors), their value and placement are particularly important. In all cases the body of the resistor should be close to the device or socket. In other words there should be very little lead length or printed-circuit foil run between comparator and resistor to radiate or pick up signals. The same applies to capacitors, pots, etc. For example, if  $R_S=10 \text{ k}\Omega$ , as little as 5 inches of lead between the resistors and the input pins can result in oscillations that are very hard to damp. Twisting these input leads tightly is the only (second best) alternative to placing resistors close to the comparator.
5. Since feedback to almost any pin of a comparator can result in oscillation, the printed-circuit layout should be engineered thoughtfully. Preferably there should be a groundplane under the LM111-N circuitry, for example, one side of a double-layer circuit card. Ground foil (or, positive supply or negative supply foil) should extend between the output and the inputs, to act as a guard. The foil connections for the inputs should be as small and compact as possible, and should be essentially surrounded by ground foil on all sides, to guard against capacitive coupling from any high-level signals (such as the output). If pins 5 and 6 are not used, they should be shorted together. If they are connected to a trim-pot, the trim-pot should be located, at most, a few inches away from the LM111-N, and the 0.01  $\mu\text{F}$  capacitor should be installed. If this capacitor cannot be used, a shielding printed-circuit foil may be advisable between pins 6 and 7. The power supply bypass capacitors should be located within a couple inches of the LM111-N. (Some other comparators require the power-supply bypass to be located immediately adjacent to the comparator.)
6. It is a standard procedure to use hysteresis (positive feedback) around a comparator, to prevent oscillation, and to avoid excessive noise on the output because the comparator is a good amplifier for its own noise. In the circuit of [Figure 41](#), the feedback from the output to the positive input will cause about 3 mV of hysteresis. However, if  $R_S$  is larger than 100 $\Omega$ , such as 50  $\text{k}\Omega$ , it would not be reasonable to simply increase the value of the positive feedback resistor above 510  $\text{k}\Omega$ . The circuit of [Figure 42](#) could be used, but it is rather awkward. See the notes in paragraph 7 below.
7. When both inputs of the LM111-N are connected to active signals, or if a high-impedance signal is driving the positive input of the LM111-N so that positive feedback would be disruptive, the circuit of [Figure 40](#) is ideal. The positive feedback is to pin 5 (one of the offset adjustment pins). It is sufficient to cause 1 to 2 mV hysteresis and sharp transitions with input triangle waves from a few Hz to hundreds of kHz. The positive-feedback signal across the 82 $\Omega$  resistor swings 240 mV below the positive supply. This signal is centered around the nominal voltage at pin 5, so this feedback does not add to the  $V_{OS}$  of the comparator. As much as 8 mV of  $V_{OS}$  can be trimmed out, using the 5  $\text{k}\Omega$  pot and 3  $\text{k}\Omega$  resistor as shown.
8. These application notes apply specifically to the LM111-N, LM211-N, LM311-N, and LF111 families of comparators, and are applicable to all high-speed comparators in general, (with the exception that not all comparators have trim pins).



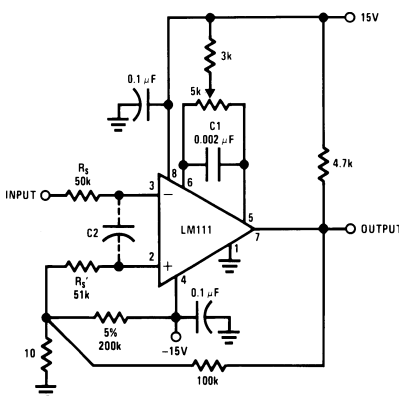
Pin connections shown are for LM111H in the LMC hermetic package.

**Figure 40. Improved Positive Feedback**



Pin connections shown are for LM111H in the LMC hermetic package.

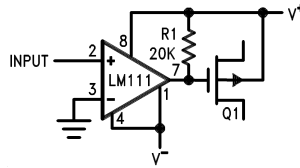
**Figure 41. Conventional Positive Feedback**



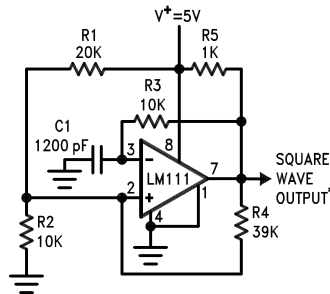
**Figure 42. Positive Feedback with High Source Resistance**

**Typical Applications**

(Pin numbers refer to LMC package)

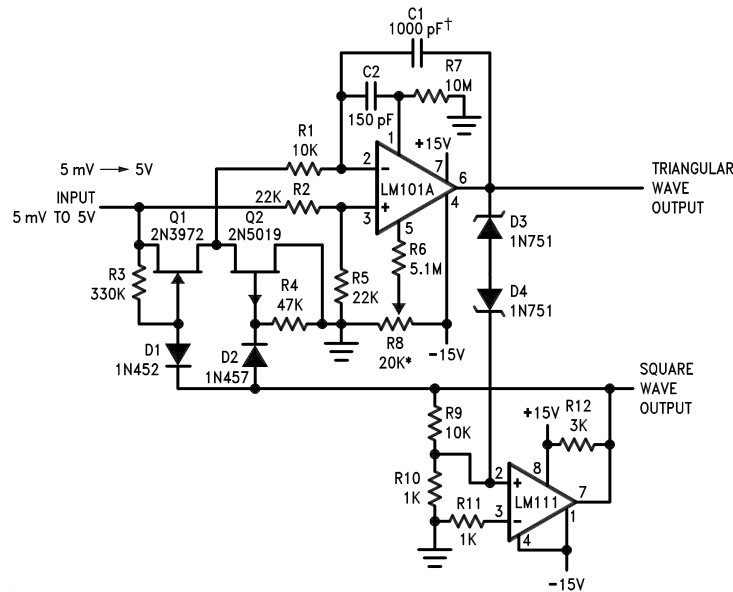


**Figure 43. Zero Crossing Detector Driving MOS Switch**



\*TTL or DTL fanout of two

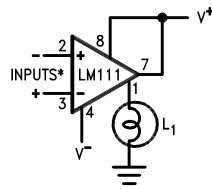
**Figure 44. 100 kHz Free Running Multivibrator**



\*Adjust for symmetrical square wave time when  $V_{IN} = 5\text{ mV}$

†Minimum capacitance 20 pF Maximum frequency 50 kHz

**Figure 45. 10 Hz to 10 kHz Voltage Controlled Oscillator**



\*Input polarity is reversed when using pin 1 as output.

Figure 46. Driving Ground-Referred Load

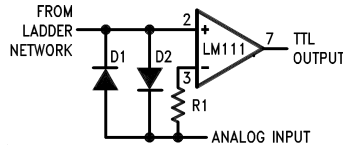
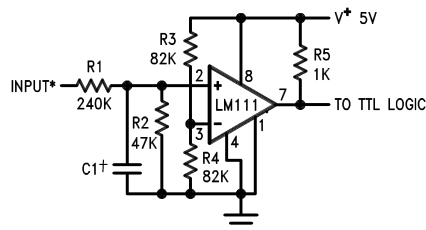


Figure 47. Using Clamp Diodes to Improve Response



\*Values shown are for a 0 to 30V logic swing and a 15V threshold.

†May be added to control speed and reduce susceptibility to noise spikes.

Figure 48. TTL Interface with High Level Logic

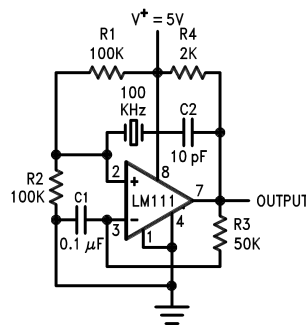


Figure 49. Crystal Oscillator

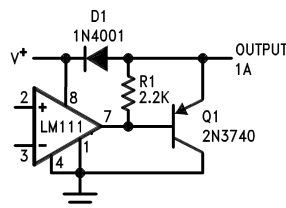
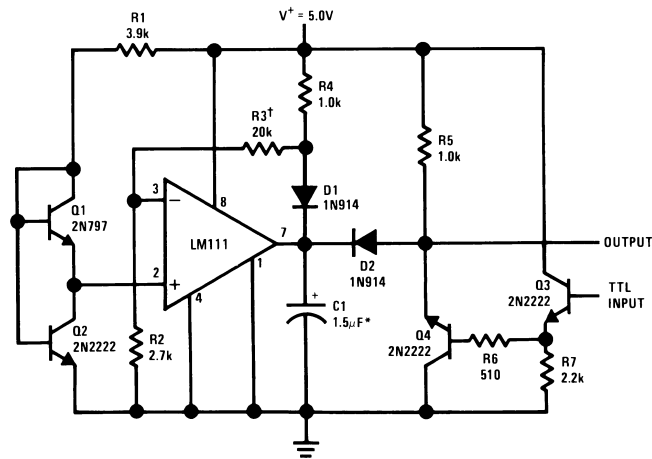
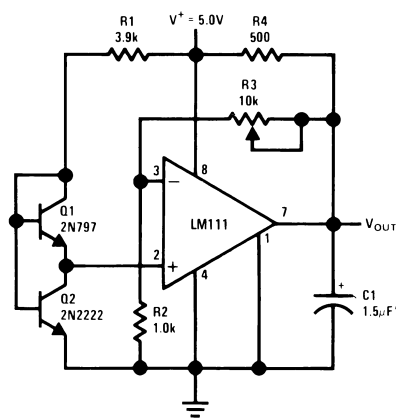


Figure 50. Comparator and Solenoid Driver



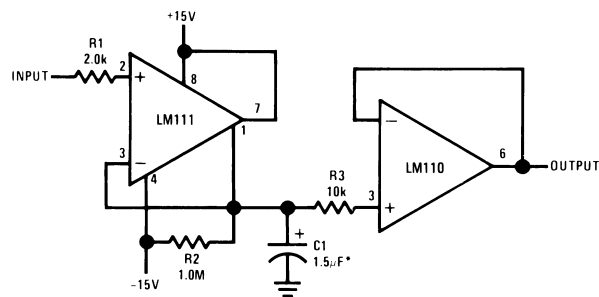
\*Solid tantalum  
 †Adjust to set clamp level

Figure 51. Precision Squarer



\*Solid tantalum

Figure 52. Low-Voltage Adjustable Reference Supply



\*Solid tantalum

Figure 53. Positive Peak Detector



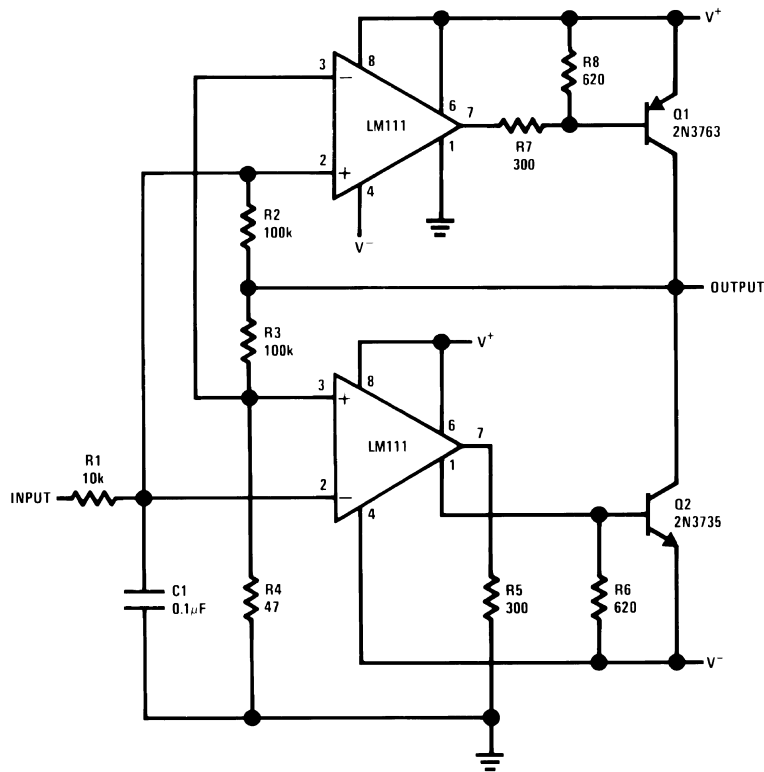


Figure 57. Switching Power Amplifier

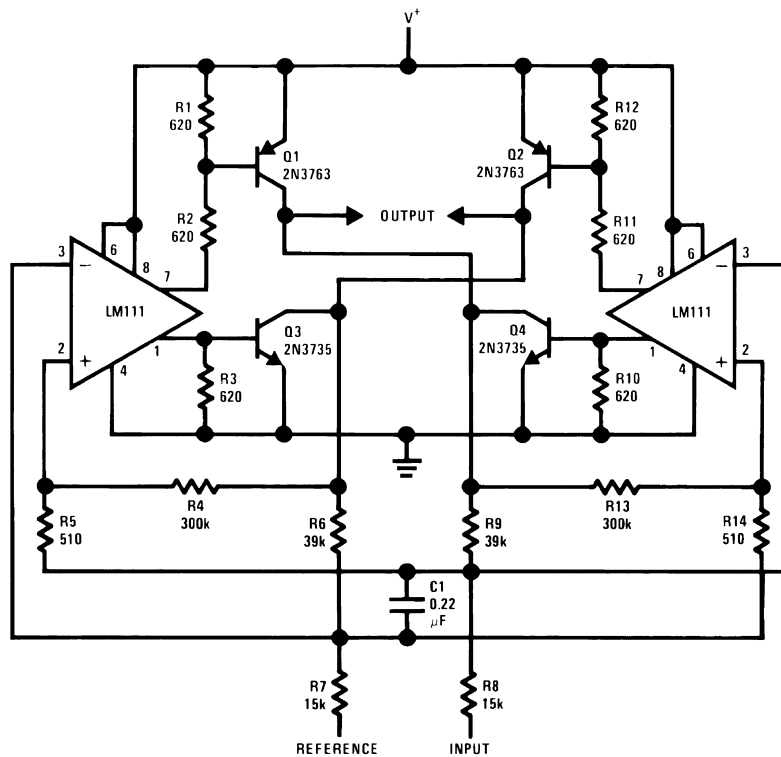
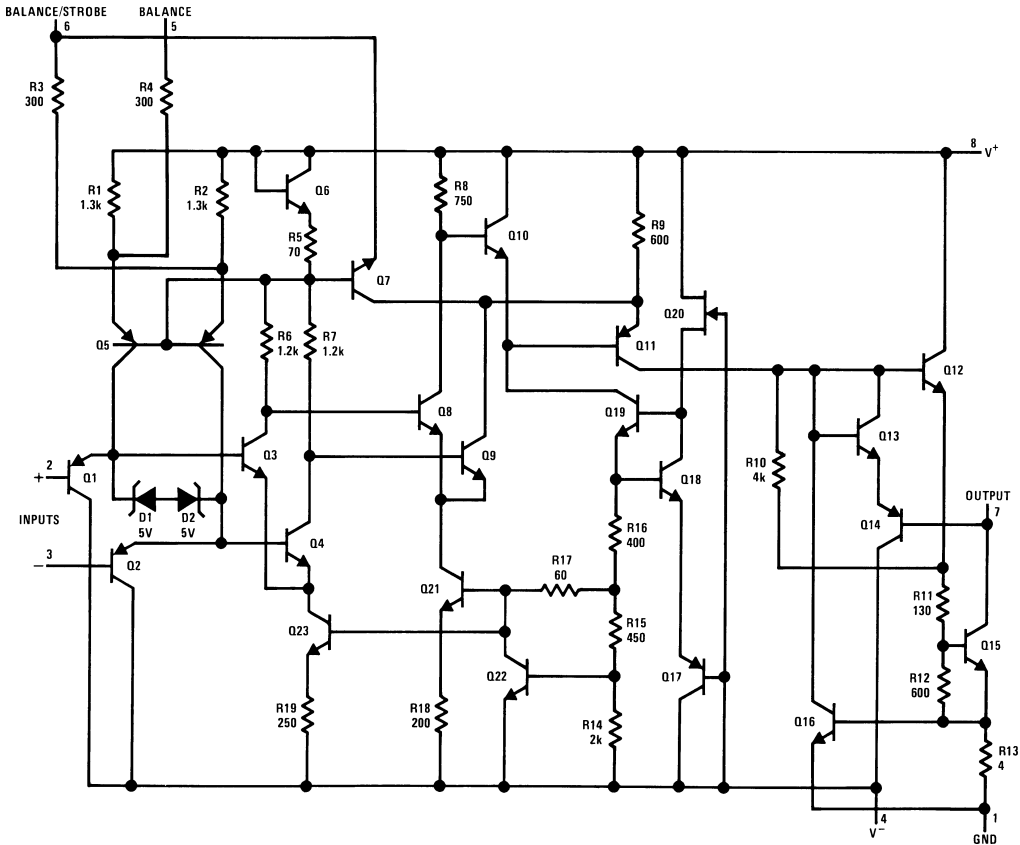


Figure 58. Switching Power Amplifier

Schematic Diagram

NOTE

Pin connections shown in the schematic diagram are for the LMC package.



Pin Diagrams

Top View

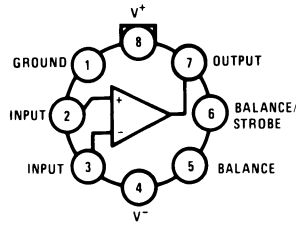


Figure 59. 8-Pin TO-99  
See LMC Package

Top View

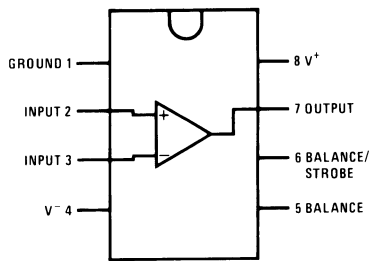


Figure 60. 8-Pin CDIP (See NAB Package)  
8-Pin SOIC (See D Package)  
8-Pin PDIP (See P Package)

Top View

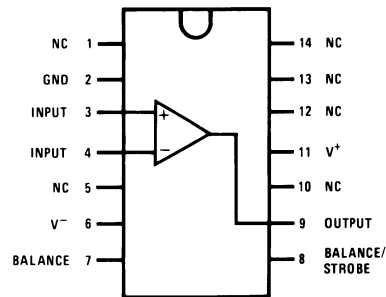


Figure 61. 14-Pin CDIP (See J Package)  
14-Pin PDIP (See NFF Package)

Top View

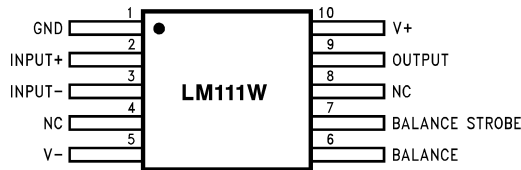


Figure 62. LM111W/883, LM111WG/883  
10-Pin CLGA (See NAD Package)  
10-Pin CLGA (See NAC Package)

---

**REVISION HISTORY**

<b>Changes from Revision D (March 2013) to Revision E</b>	<b>Page</b>
<hr/> <ul style="list-style-type: none"><li>• Changed layout of National Data Sheet to TI format .....</li></ul>	<hr/> <a href="#">20</a>

**PACKAGING INFORMATION**

Orderable Device	Status (1)	Package Type	Package Drawing	Pins	Package Qty	Eco Plan (2)	Lead/Ball Finish (6)	MSL Peak Temp (3)	Op Temp (°C)	Device Marking (4/5)	Samples
LM111H	ACTIVE	TO-99	LMC	8	500	TBD	Call TI	Call TI	-55 to 125	LM111H	<a href="#">Samples</a>
LM111H/NOPB	ACTIVE	TO-99	LMC	8	500	Green (RoHS & no Sb/Br)	POST-PLATE	Level-1-NA-UNLIM	-55 to 125	LM111H	<a href="#">Samples</a>
LM111J-8	ACTIVE	CDIP	NAB	8	40	TBD	Call TI	Call TI	-55 to 125	LM111J-8	<a href="#">Samples</a>
LM311H	ACTIVE	TO-99	LMC	8	500	TBD	Call TI	Call TI	0 to 70	LM311H	<a href="#">Samples</a>
LM311H/NOPB	ACTIVE	TO-99	LMC	8	500	Green (RoHS & no Sb/Br)	POST-PLATE	Level-1-NA-UNLIM	0 to 70	LM311H	<a href="#">Samples</a>
LM311M	ACTIVE	SOIC	D	8	95	TBD	Call TI	Call TI	0 to 70	LM 311M	<a href="#">Samples</a>
LM311M/NOPB	ACTIVE	SOIC	D	8	95	Green (RoHS & no Sb/Br)	CU SN	Level-1-260C-UNLIM	0 to 70	LM 311M	<a href="#">Samples</a>
LM311MX	ACTIVE	SOIC	D	8	2500	TBD	Call TI	Call TI	0 to 70	LM 311M	<a href="#">Samples</a>
LM311MX/NOPB	ACTIVE	SOIC	D	8	2500	Green (RoHS & no Sb/Br)	CU SN	Level-1-260C-UNLIM	0 to 70	LM 311M	<a href="#">Samples</a>
LM311N	ACTIVE	PDIP	P	8	40	TBD	Call TI	Call TI	0 to 70	LM 311N	<a href="#">Samples</a>
LM311N/NOPB	ACTIVE	PDIP	P	8	40	Green (RoHS & no Sb/Br)	SN   CU SN	Level-1-NA-UNLIM	0 to 70	LM 311N	<a href="#">Samples</a>
MLM311P	ACTIVE	PDIP	P	8	40	TBD	Call TI	Call TI	0 to 70	LM 311N	<a href="#">Samples</a>

(1) The marketing status values are defined as follows:

**ACTIVE:** Product device recommended for new designs.

**LIFEBUY:** TI has announced that the device will be discontinued, and a lifetime-buy period is in effect.

**NRND:** Not recommended for new designs. Device is in production to support existing customers, but TI does not recommend using this part in a new design.

**PREVIEW:** Device has been announced but is not in production. Samples may or may not be available.

**OBSOLETE:** TI has discontinued the production of the device.

(2) Eco Plan - The planned eco-friendly classification: Pb-Free (RoHS), Pb-Free (RoHS Exempt), or Green (RoHS & no Sb/Br) - please check <http://www.ti.com/productcontent> for the latest availability information and additional product content details.

**TBD:** The Pb-Free/Green conversion plan has not been defined.

**Pb-Free (RoHS):** TI's terms "Lead-Free" or "Pb-Free" mean semiconductor products that are compatible with the current RoHS requirements for all 6 substances, including the requirement that lead not exceed 0.1% by weight in homogeneous materials. Where designed to be soldered at high temperatures, TI Pb-Free products are suitable for use in specified lead-free processes.

---

**Pb-Free (RoHS Exempt):** This component has a RoHS exemption for either 1) lead-based flip-chip solder bumps used between the die and package, or 2) lead-based die adhesive used between the die and leadframe. The component is otherwise considered Pb-Free (RoHS compatible) as defined above.

**Green (RoHS & no Sb/Br):** TI defines "Green" to mean Pb-Free (RoHS compatible), and free of Bromine (Br) and Antimony (Sb) based flame retardants (Br or Sb do not exceed 0.1% by weight in homogeneous material)

<sup>(3)</sup> MSL, Peak Temp. - The Moisture Sensitivity Level rating according to the JEDEC industry standard classifications, and peak solder temperature.

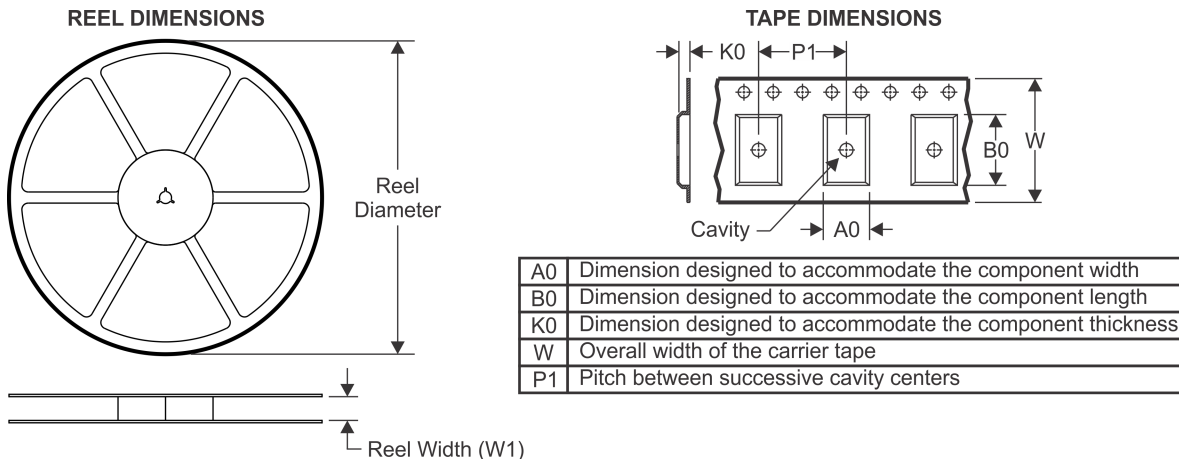
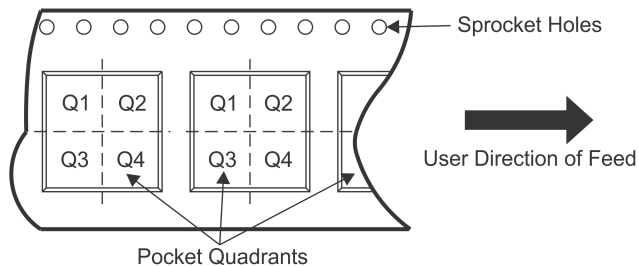
<sup>(4)</sup> There may be additional marking, which relates to the logo, the lot trace code information, or the environmental category on the device.

<sup>(5)</sup> Multiple Device Markings will be inside parentheses. Only one Device Marking contained in parentheses and separated by a "~" will appear on a device. If a line is indented then it is a continuation of the previous line and the two combined represent the entire Device Marking for that device.

<sup>(6)</sup> Lead/Ball Finish - Orderable Devices may have multiple material finish options. Finish options are separated by a vertical ruled line. Lead/Ball Finish values may wrap to two lines if the finish value exceeds the maximum column width.

**Important Information and Disclaimer:** The information provided on this page represents TI's knowledge and belief as of the date that it is provided. TI bases its knowledge and belief on information provided by third parties, and makes no representation or warranty as to the accuracy of such information. Efforts are underway to better integrate information from third parties. TI has taken and continues to take reasonable steps to provide representative and accurate information but may not have conducted destructive testing or chemical analysis on incoming materials and chemicals. TI and TI suppliers consider certain information to be proprietary, and thus CAS numbers and other limited information may not be available for release.

In no event shall TI's liability arising out of such information exceed the total purchase price of the TI part(s) at issue in this document sold by TI to Customer on an annual basis.

**TAPE AND REEL INFORMATION**

**QUADRANT ASSIGNMENTS FOR PIN 1 ORIENTATION IN TAPE**


\*All dimensions are nominal

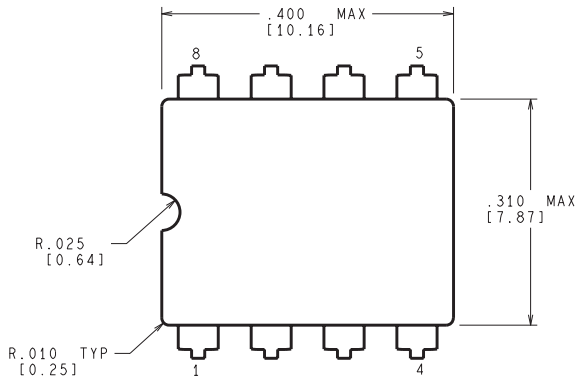
Device	Package Type	Package Drawing	Pins	SPQ	Reel Diameter (mm)	Reel Width W1 (mm)	A0 (mm)	B0 (mm)	K0 (mm)	P1 (mm)	W (mm)	Pin1 Quadrant
LM311MX	SOIC	D	8	2500	330.0	12.4	6.5	5.4	2.0	8.0	12.0	Q1
LM311MX/NOPB	SOIC	D	8	2500	330.0	12.4	6.5	5.4	2.0	8.0	12.0	Q1

**TAPE AND REEL BOX DIMENSIONS**

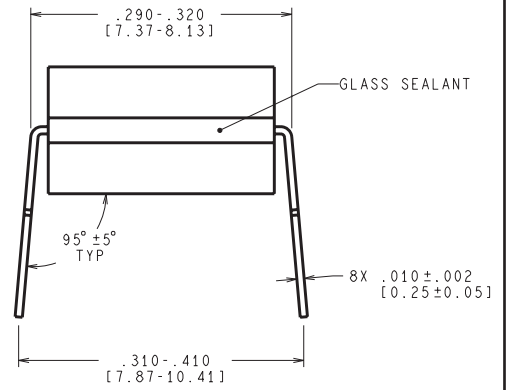
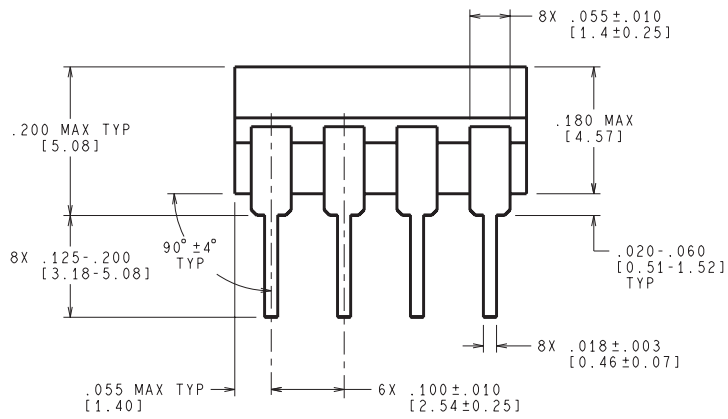

\*All dimensions are nominal

Device	Package Type	Package Drawing	Pins	SPQ	Length (mm)	Width (mm)	Height (mm)
LM311MX	SOIC	D	8	2500	367.0	367.0	35.0
LM311MX/NOPB	SOIC	D	8	2500	367.0	367.0	35.0

NAB0008A



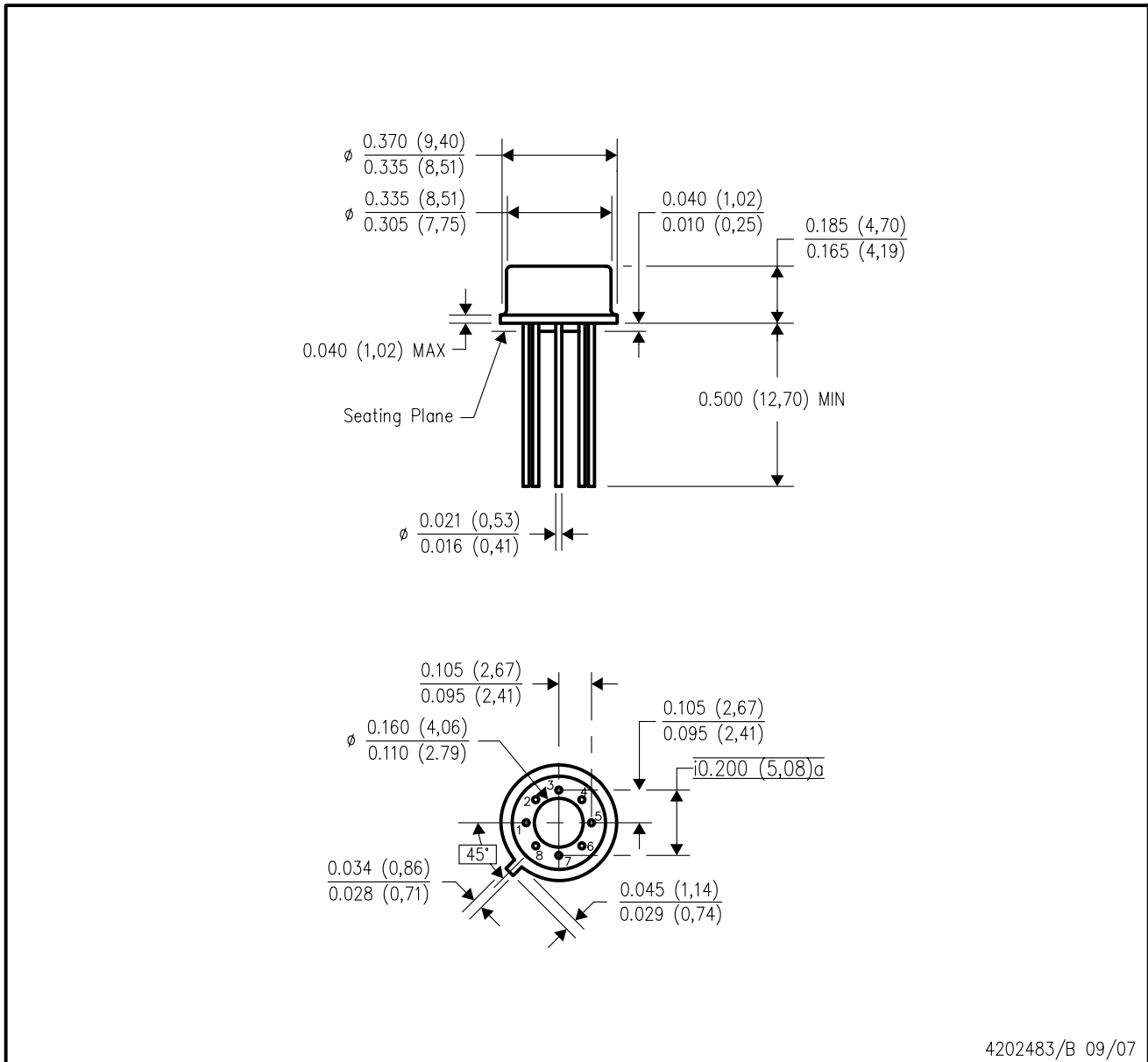
CONTROLLING DIMENSION IS INCH  
VALUES IN [ ] ARE MILLIMETERS



J08A (Rev M)

LMC (O-MBCY-W8)

METAL CYLINDRICAL PACKAGE



- NOTES:
- A. All linear dimensions are in inches (millimeters).
  - B. This drawing is subject to change without notice.
  - C. Leads in true position within 0.010 (0,25) R @ MMC at seating plane.
  - D. Pin numbers shown for reference only. Numbers may not be marked on package.
  - E. Falls within JEDEC MO-002/TO-99.

P (R-PDIP-T8)

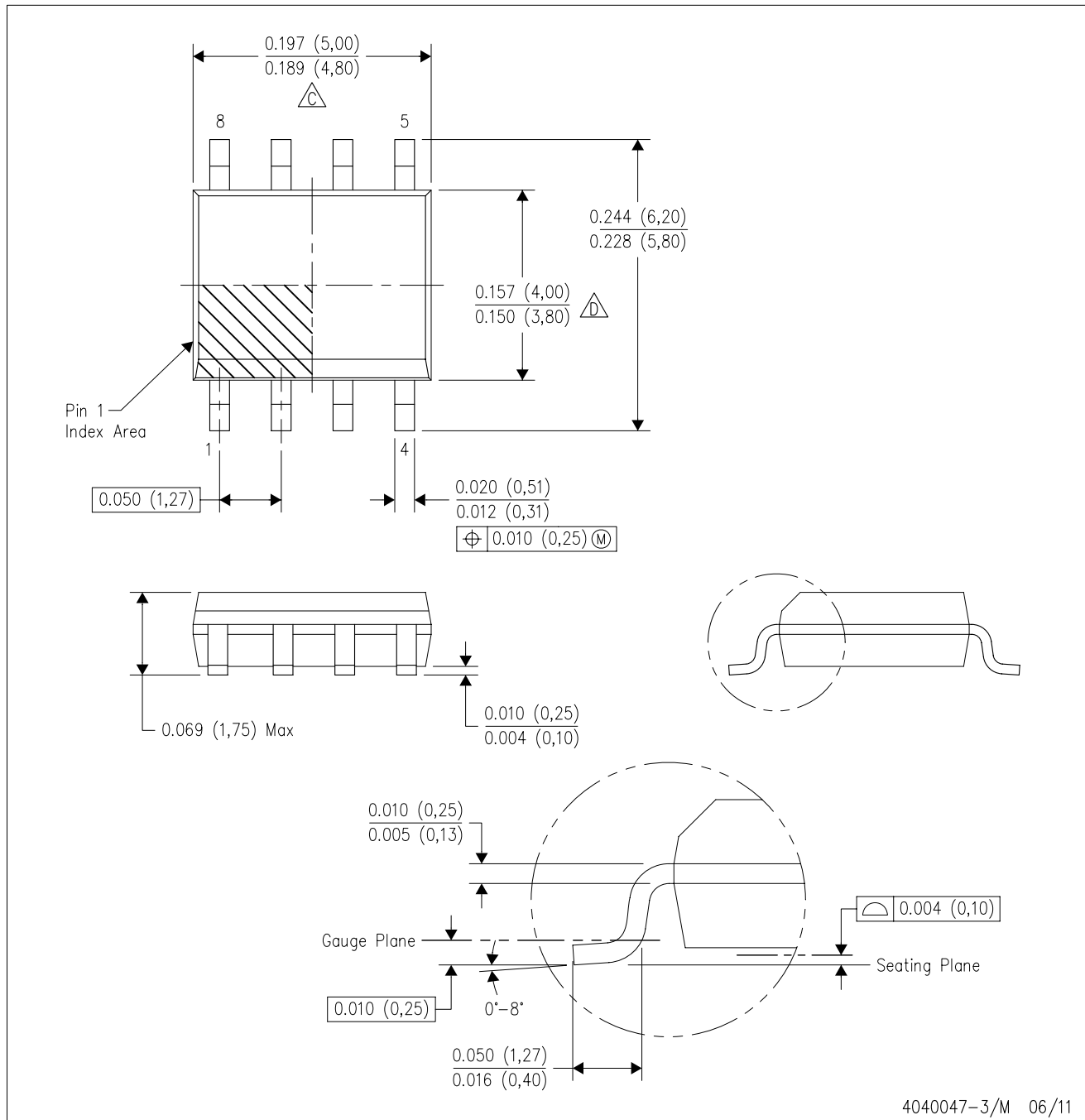
PLASTIC DUAL-IN-LINE PACKAGE



- NOTES:
- A. All linear dimensions are in inches (millimeters).
  - B. This drawing is subject to change without notice.
  - C. Falls within JEDEC MS-001 variation BA.

D (R-PDSO-G8)

PLASTIC SMALL OUTLINE



## IMPORTANT NOTICE

Texas Instruments Incorporated and its subsidiaries (TI) reserve the right to make corrections, enhancements, improvements and other changes to its semiconductor products and services per JESD46, latest issue, and to discontinue any product or service per JESD48, latest issue. Buyers should obtain the latest relevant information before placing orders and should verify that such information is current and complete. All semiconductor products (also referred to herein as "components") are sold subject to TI's terms and conditions of sale supplied at the time of order acknowledgment.

TI warrants performance of its components to the specifications applicable at the time of sale, in accordance with the warranty in TI's terms and conditions of sale of semiconductor products. Testing and other quality control techniques are used to the extent TI deems necessary to support this warranty. Except where mandated by applicable law, testing of all parameters of each component is not necessarily performed.

TI assumes no liability for applications assistance or the design of Buyers' products. Buyers are responsible for their products and applications using TI components. To minimize the risks associated with Buyers' products and applications, Buyers should provide adequate design and operating safeguards.

TI does not warrant or represent that any license, either express or implied, is granted under any patent right, copyright, mask work right, or other intellectual property right relating to any combination, machine, or process in which TI components or services are used. Information published by TI regarding third-party products or services does not constitute a license to use such products or services or a warranty or endorsement thereof. Use of such information may require a license from a third party under the patents or other intellectual property of the third party, or a license from TI under the patents or other intellectual property of TI.

Reproduction of significant portions of TI information in TI data books or data sheets is permissible only if reproduction is without alteration and is accompanied by all associated warranties, conditions, limitations, and notices. TI is not responsible or liable for such altered documentation. Information of third parties may be subject to additional restrictions.

Resale of TI components or services with statements different from or beyond the parameters stated by TI for that component or service voids all express and any implied warranties for the associated TI component or service and is an unfair and deceptive business practice. TI is not responsible or liable for any such statements.

Buyer acknowledges and agrees that it is solely responsible for compliance with all legal, regulatory and safety-related requirements concerning its products, and any use of TI components in its applications, notwithstanding any applications-related information or support that may be provided by TI. Buyer represents and agrees that it has all the necessary expertise to create and implement safeguards which anticipate dangerous consequences of failures, monitor failures and their consequences, lessen the likelihood of failures that might cause harm and take appropriate remedial actions. Buyer will fully indemnify TI and its representatives against any damages arising out of the use of any TI components in safety-critical applications.

In some cases, TI components may be promoted specifically to facilitate safety-related applications. With such components, TI's goal is to help enable customers to design and create their own end-product solutions that meet applicable functional safety standards and requirements. Nonetheless, such components are subject to these terms.

No TI components are authorized for use in FDA Class III (or similar life-critical medical equipment) unless authorized officers of the parties have executed a special agreement specifically governing such use.

Only those TI components which TI has specifically designated as military grade or "enhanced plastic" are designed and intended for use in military/aerospace applications or environments. Buyer acknowledges and agrees that any military or aerospace use of TI components which have **not** been so designated is solely at the Buyer's risk, and that Buyer is solely responsible for compliance with all legal and regulatory requirements in connection with such use.

TI has specifically designated certain components as meeting ISO/TS16949 requirements, mainly for automotive use. In any case of use of non-designated products, TI will not be responsible for any failure to meet ISO/TS16949.

### Products

Audio	<a href="http://www.ti.com/audio">www.ti.com/audio</a>
Amplifiers	<a href="http://amplifier.ti.com">amplifier.ti.com</a>
Data Converters	<a href="http://dataconverter.ti.com">dataconverter.ti.com</a>
DLP® Products	<a href="http://www.dlp.com">www.dlp.com</a>
DSP	<a href="http://dsp.ti.com">dsp.ti.com</a>
Clocks and Timers	<a href="http://www.ti.com/clocks">www.ti.com/clocks</a>
Interface	<a href="http://interface.ti.com">interface.ti.com</a>
Logic	<a href="http://logic.ti.com">logic.ti.com</a>
Power Mgmt	<a href="http://power.ti.com">power.ti.com</a>
Microcontrollers	<a href="http://microcontroller.ti.com">microcontroller.ti.com</a>
RFID	<a href="http://www.ti-rfid.com">www.ti-rfid.com</a>
OMAP Applications Processors	<a href="http://www.ti.com/omap">www.ti.com/omap</a>
Wireless Connectivity	<a href="http://www.ti.com/wirelessconnectivity">www.ti.com/wirelessconnectivity</a>

### Applications

Automotive and Transportation	<a href="http://www.ti.com/automotive">www.ti.com/automotive</a>
Communications and Telecom	<a href="http://www.ti.com/communications">www.ti.com/communications</a>
Computers and Peripherals	<a href="http://www.ti.com/computers">www.ti.com/computers</a>
Consumer Electronics	<a href="http://www.ti.com/consumer-apps">www.ti.com/consumer-apps</a>
Energy and Lighting	<a href="http://www.ti.com/energy">www.ti.com/energy</a>
Industrial	<a href="http://www.ti.com/industrial">www.ti.com/industrial</a>
Medical	<a href="http://www.ti.com/medical">www.ti.com/medical</a>
Security	<a href="http://www.ti.com/security">www.ti.com/security</a>
Space, Avionics and Defense	<a href="http://www.ti.com/space-avionics-defense">www.ti.com/space-avionics-defense</a>
Video and Imaging	<a href="http://www.ti.com/video">www.ti.com/video</a>

### TI E2E Community

[e2e.ti.com](http://e2e.ti.com)