



LM193, LM293, LM393

Low power dual voltage comparators

Features

- Wide single-supply voltage range or dual supplies: +2 V to +36 V or ± 1 V to ± 18 V
- Very low supply current (0.4 mA) independent of supply voltage (1 mW/comparator at +5 V)
- Low input bias current: 25 nA typ.
- Low input offset current: ± 5 nA typ.
- Low input offset voltage: ± 1 mV typ.
- Input common-mode voltage range includes ground
- Low output saturation voltage: 250 mV typ. ($I_{\text{sink}} = 4$ mA)
- Differential input voltage range equal to the supply voltage
- TTL, DTL, ECL, MOS, CMOS compatible outputs

Description

These devices consist of two independent low voltage comparators designed specifically to operate from a single supply over a wide range of voltages. Operation from split power supplies is also possible.

These comparators also have a unique characteristic in that the input common-mode voltage range includes ground even though operated from a single power supply voltage.



DIP8
(Plastic package)



SO-8
(Plastic micropackage)



TSSOP8
(Thin shrink small outline package)



MiniSO-8
(Plastic micropackage)

Pin connections (top view)

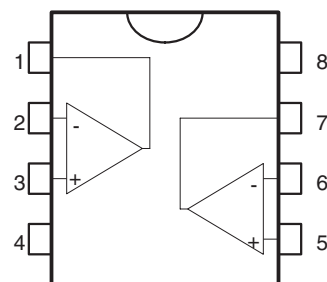

- 1 - Output 1
- 2 - Inverting input 1
- 3 - Non-inverting input 1
- 4 - V_{CC}^-
- 5 - Non-inverting input 2
- 6 - Inverting input 2
- 7 - Output 2
- 8 - V_{CC}^+

2 Absolute maximum ratings and operating conditions

Table 1. Absolute maximum ratings

Symbol	Parameter	Value	Unit
V_{CC}	Supply voltage	± 18 or 36	V
V_{id}	Differential input voltage	± 36	V
V_{in}	Input voltage	-0.3 to +36	V
	Output short-circuit to ground ⁽¹⁾	Infinite	
R_{thja}	Thermal resistance junction to ambient ⁽²⁾		°C/W
	SO-8	125	
	TSSOP8	120	
	DIP8	85	
R_{thjc}	Thermal resistance junction to case ⁽²⁾		°C/W
	SO-8	40	
	TSSOP8	37	
	DIP8	41	
	MiniSO-8	39	
T_j	Maximum junction temperature	150	°C
T_{stg}	Storage temperature range	-65 to +150	°C
ESD	HBM: human body model ⁽³⁾	800	V
	MM: machine model ⁽⁴⁾	200	
	CDM: charged device model ⁽⁵⁾	1500	

- Short-circuits from the output to V_{CC}^+ can cause excessive heating and potential destruction. The maximum output current is approximately 20 mA independent of the magnitude of V_{CC}^+ .
- Short-circuits can cause excessive heating and destructive dissipation. Values are typical.
- Human body model: a 100 pF capacitor is charged to the specified voltage, then discharged through a 1.5 k Ω resistor between two pins of the device. This is done for all couples of connected pin combinations while the other pins are floating.
- Machine model: a 200 pF capacitor is charged to the specified voltage, then discharged directly between two pins of the device with no external series resistor (internal resistor < 5 Ω). This is done for all couples of connected pin combinations while the other pins are floating.
- Charged device model: all pins and the package are charged together to the specified voltage and then discharged directly to the ground through only one pin. This is done for all pins.

Table 2. Operating conditions

Symbol	Parameter	Value	Unit
V_{CC}	Supply voltage	2 to 36	V
V_{icm}	Common mode input voltage range ($V_{CC}^+ = 30V$) ⁽¹⁾ $T_{amb} = +25^\circ C$ $T_{min} \leq T_{amb} \leq T_{max}$	0 to $V_{CC}^+ - 1.5$ 0 to $V_{CC}^+ - 2$	V
T_{oper}	Operating free-air temperature range LM193, LM193A LM293, LM293A LM393, LM393A	-55 to +125 -40 to +105 0 to +70	°C

- The input common-mode voltage of either input signal voltage should not be allowed to go negative by more than 0.3 V. The high end of the common-mode voltage range is $V_{CC}^+ - 1.5$ V, but either or both inputs can go to +30 V without damage.

3 Electrical characteristics

Table 3. $V_{CC}^+ = +5V$, $V_{CC}^- = 0V$, $T_{amb} = +25^\circ C$ (unless otherwise specified)

Symbol	Parameter	LM193A - LM293A LM393A			LM193- LM293 LM393			Unit
		Min.	Typ.	Max.	Min	Typ.	Max.	
V_{io}	Input offset voltage ⁽¹⁾ $T_{min} \leq T_{amb} \leq T_{max}$		1	2 4		1	5 9	mV
I_{io}	Input offset current $T_{min} \leq T_{amb} \leq T_{max}$		3	25 100		5	50 150	nA
I_{ib}	Input bias current (I^+ or I^-) ⁽²⁾ $T_{min} \leq T_{amb} \leq T_{max}$		25	100 300		25	250 400	nA
A_{vd}	Large signal voltage gain $V_{CC} = 15V$, $R_L = 15k\Omega$, $V_o = 1V$ to $11V$	50	200		50	200		V/mV
I_{CC}	Supply current (all comparators) $V_{CC} = +5V$, no load $V_{CC} = +30V$, no load		0.4 1	1 2.5		0.4 1	1 2.5	mA
V_{id}	Differential input voltage ⁽³⁾			V_{CC}^+			V_{CC}^+	
V_{OL}	Low level output voltage $V_{id} = -1V$, $I_{sink} = 4mA$ $T_{min} \leq T_{amb} \leq T_{max}$		250	400 700		250	400 700	mV
I_{OH}	High level output current $V_{CC} = V_o = 30V$, $V_{id} = 1V$ $T_{min} \leq T_{amb} \leq T_{max}$		0.1	1		0.1	1	nA μA
I_{sink}	Output sink current $V_{id} = 1V$, $V_o = 1.5V$	6	16		6	16		mA
t_{re}	Response time ⁽⁴⁾ $R_L = 5.1k\Omega$ connected to V_{CC}^+		1.3			1.3		μs
t_{rel}	Large signal response time $R_L = 5.1k\Omega$ connected to V_{CC}^+ , $e_1 = TTL$, $V_{(ref)} = +1.4V$		300			300		ns

1. At output switch point, $V_o \approx 1.4V$, $R_s = 0$ with V_{CC}^+ from 5V to 30V, and over the full common-mode range (0V to $V_{CC}^+ - 1.5V$).
2. The direction of the input current is out of the IC due to the PNP input stage. This current is essentially constant, independent of the state of the output, so no loading charge exists on the reference of input lines.
3. The response time specified is for a 100 mV input step with 5 mV overdrive. For larger overdrive signals 300 ns can be obtained.
4. Positive excursions of input voltage may exceed the power supply level. As long as the other voltage remains within the common-mode range, the comparator will provide a proper output state. The low input voltage state must not be less than -0.3V (or 0.3V below the negative power supply, if used).

5.1 DIP8 package information

Figure 20. DIP8 package mechanical drawing

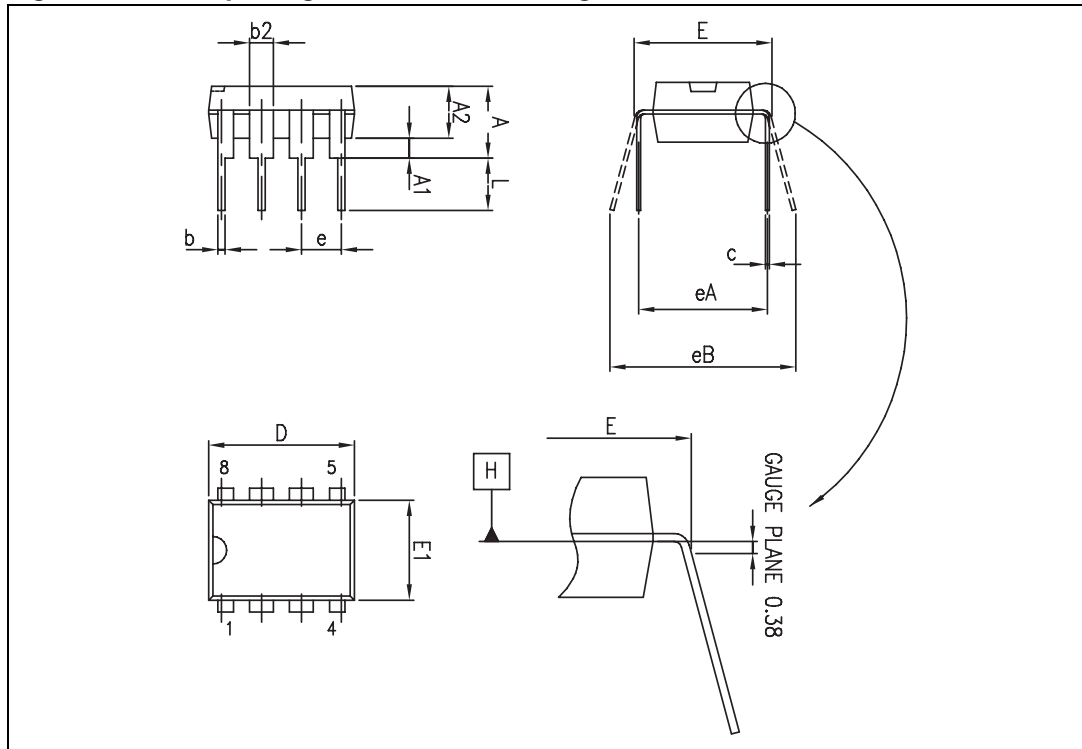

Table 4. DIP8 package mechanical data

Ref.	Dimensions					
	Millimeters			Inches		
	Min.	Typ.	Max.	Min.	Typ.	Max.
A			5.33			0.210
A1	0.38			0.015		
A2	2.92	3.30	4.95	0.115	0.130	0.195
b	0.36	0.46	0.56	0.014	0.018	0.022
b2	1.14	1.52	1.78	0.045	0.060	0.070
c	0.20	0.25	0.36	0.008	0.010	0.014
D	9.02	9.27	10.16	0.355	0.365	0.400
E	7.62	7.87	8.26	0.300	0.310	0.325
E1	6.10	6.35	7.11	0.240	0.250	0.280
e		2.54			0.100	
eA		7.62			0.300	
eB			10.92			0.430
L	2.92	3.30	3.81	0.115	0.130	0.150

6 Ordering information

Table 8. Order codes

Order code	Temperature range	Package	Packing	Marking
LM193AD LM193ADT	-55°C, +125°C	SO-8	Tube or Tape & reel	193A
LM193D LM193DT				193
LM193AYD ⁽¹⁾ LM193AYDT		SO-8 (Automotive grade)	Tube or Tape & reel	193AY
LM193YD ⁽¹⁾ LM193YDT				193Y
LM193AN		DIP8	Tube	LM193AN
LM193N				LM193N
LM293AD LM293ADT	-40°C, +105°C	SO-8	Tube or Tape & reel	293A
LM293D LM293DT				293
LM293AYD ⁽¹⁾ LM293AYDT ⁽¹⁾		SO-8 (Automotive grade)	Tube or Tape & reel	293AY
LM293YD ⁽¹⁾ LM293YDT ⁽¹⁾				293Y
LM293AN		DIP8	Tube	LM293AN
LM293N				LM293N
LM293PT		TSSOP8	Tape & reel	293
LM293ST		MiniSO-8	Tape & reel	K512
LM393AD LM393ADT	0°C, +70°C	SO-8	Tube or Tape & reel	393A
LM393D LM393DT				393
LM393AYD ⁽¹⁾ LM393AYDT ⁽¹⁾		SO-8 (Automotive grade)	Tube or Tape & reel	393AY
LM393YD ⁽¹⁾ LM393YDT ⁽¹⁾				393Y
LM393AN		DIP8	Tube	LM393AN
LM393N				LM393N
LM393PT		TSSOP8	Tape & reel	393
LM393ST		MiniSO-8	Tape & reel	M393

1. Qualified and characterized according to AEC Q100 and Q003 or equivalent, advanced screening according to AEC Q001 & Q 002 or equivalent.