

Very low drop voltage regulators with inhibit function

Features

- Very low dropout voltage (0.15V typ. at 10mA load)
- Low quiescent current (typ. 2.5mA, at 100mA load)
- Output current up to 100mA
- Adjustable (from $V_{OUT} = 2.5V$ only SO-8) and fixed (3.3V & 5V) output voltage version
- Internal current and thermal limit
- Load dump protection up to 60V
- Reverse transient protection up to -50V
- Temperature range: -40 to 125°C
- Package available: TO-92, DPAK, TO-220, SO-8 (with inhibit control)

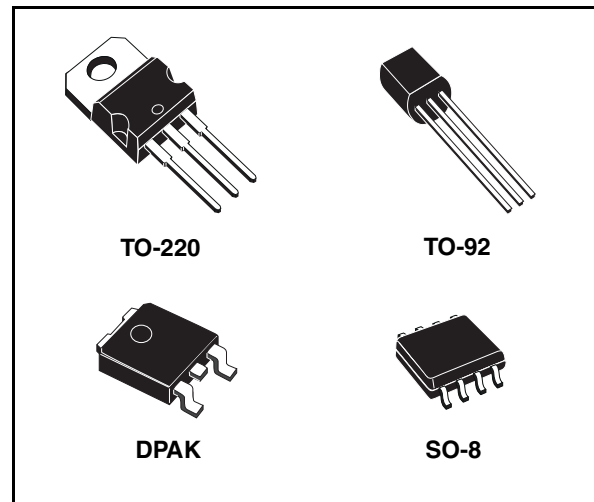

Description

The LM2931xx are very low drop regulators. The very low drop voltage and the low quiescent current make them particular suitable for low noise, low power applications and in battery powered systems. In the 8 pin configuration (SO-8), fully compatible to the older L78L00 family, a shut down Logic Control function is available.

This means that when the device is used as a local regulator is possible to put a part of the

board in stand-by decreasing the total power consumption. Ideal for automotive application the LM2931 is protected from reverse battery installations or 2 battery jumps. During the transient, such as a load dump (60V) when the input voltage can exceed the specified maximum operating input voltage (26V), the regulator will automatically shut down to protect both internal circuit and the load.

Table 1. Device summary

Part number
LM2931xx
LM2931Axx50
LM2931Bxx50

Contents

1	Diagram	3
2	Pin configuration	4
3	Maximum ratings	5
4	Application circuits	6
5	Electrical characteristics	7
6	Typical characteristics	12
7	Package mechanical data	16
8	Order codes	24
9	Revision history	25

1 Diagram

Figure 1. Schematic diagram

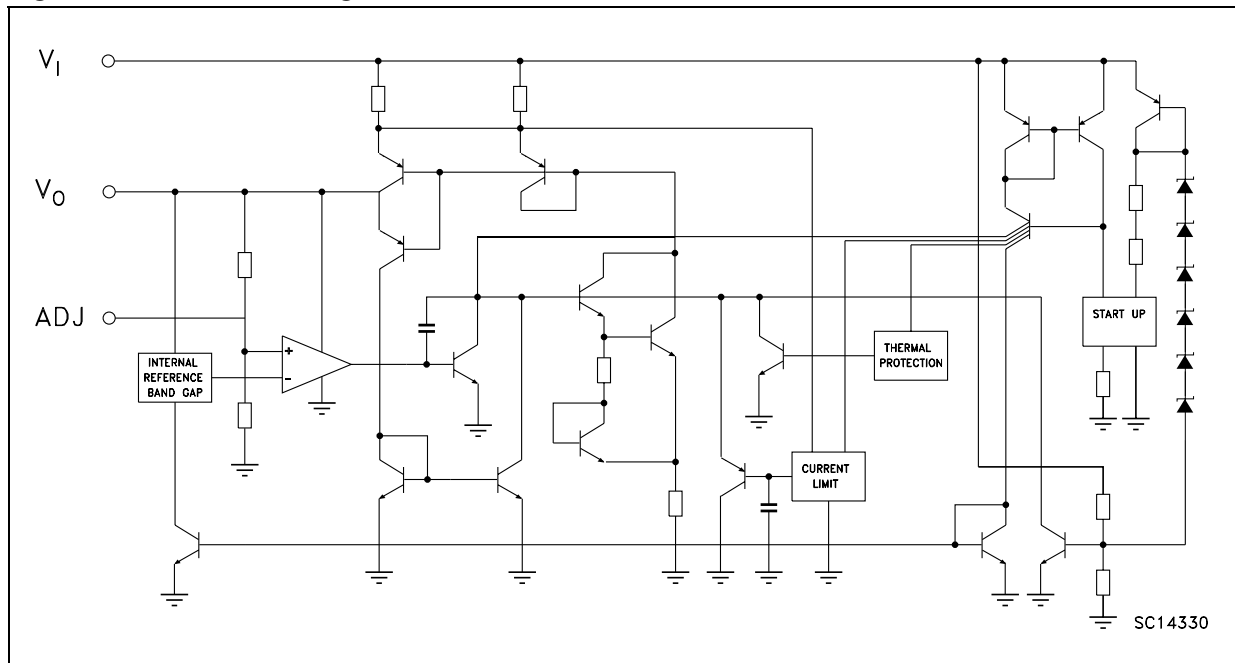

2 Pin configuration

Figure 2. Pin connections (top view)

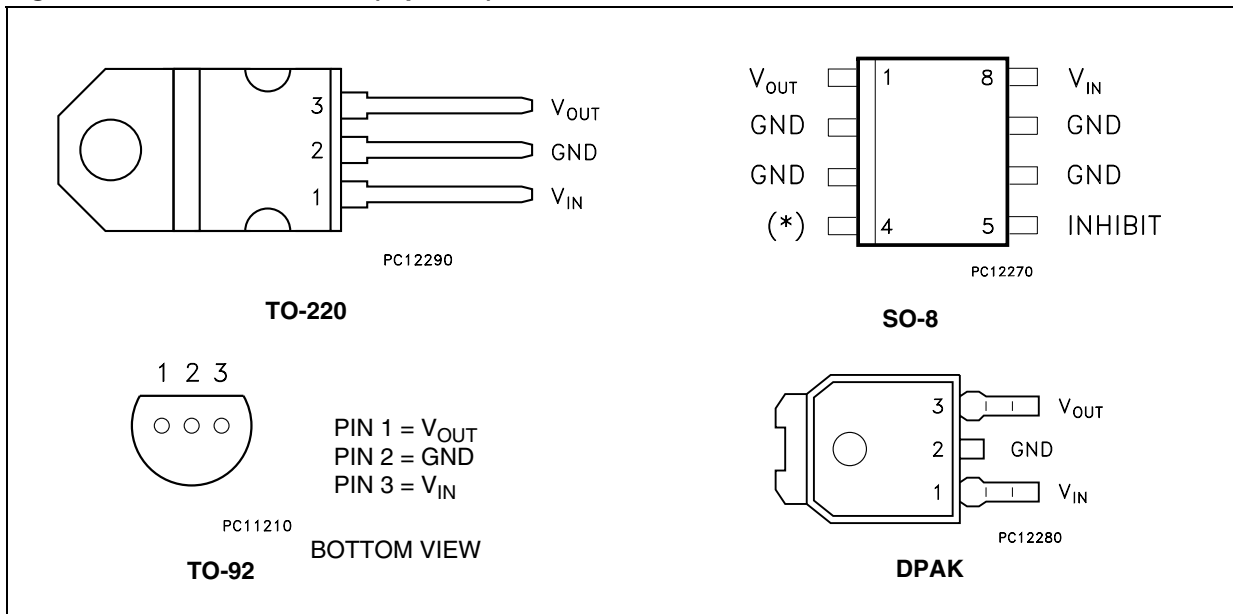

3 Maximum ratings

Table 2. Absolute maximum ratings

Symbol	Parameter	Value	Unit
V_I	DC Positive input voltage	40	V
V_I	DC Reverse input voltage	-15	V
V_I	Transient input voltage ($\tau < 100\text{ms}$)	60	V
V_I	Transient reverse input voltage ($\tau < 100\text{ms}$)	-50	V
V_{INH}	Inhibit input voltage	40	V
I_O	Output current	Internally Limited	
T_{STG}	Storage temperature range	-65 to 150	°C
T_{OP}	Operating junction temperature range	-40 to 125	°C

Note: Absolute Maximum Ratings are those values beyond which damage to the device may occur. Functional operation under these condition is not implied

Table 3. Thermal Data

Symbol	Parameter	TO-220	SO-8	DPAK	TO-92	Unit
R_{thJC}	Thermal resistance junction-case	3	20	8		°C/W
R_{thJA}	Thermal resistance junction-ambient	50	55 ⁽¹⁾	100	200	°C/W

1. Considering 6 cm² of copper board heat-sink.

4 Application circuits

Figure 3. Application circuits for fixed output

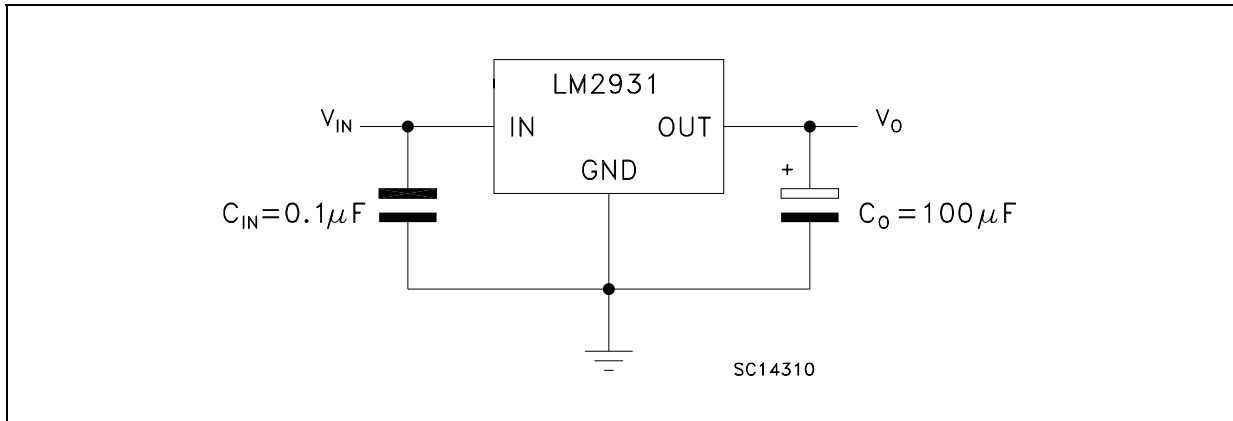
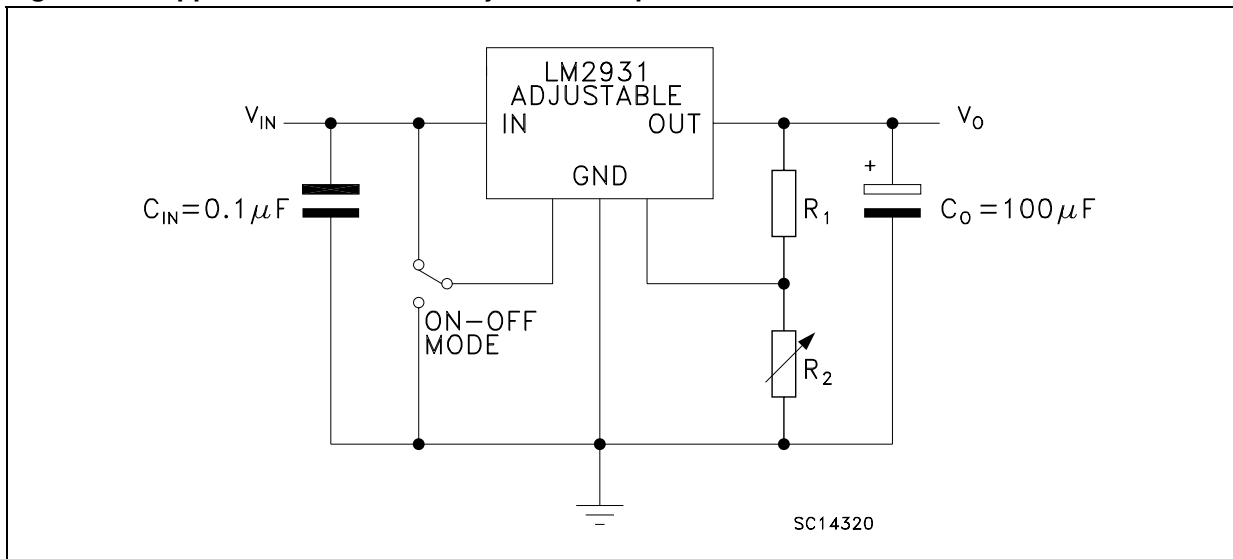

Figure 4. Application circuits for adjustable output



R_1 suggested value = 27K Ω

$$V_O = V_{REF} (R_1 + R_2) / R_1$$

5 Electrical characteristics

Table 4. Electrical characteristics of LM2931A 3.3V (refer to the test circuits, $T_J = 25^\circ\text{C}$, $C_I = 0.1 \mu\text{F}$, $C_O = 100 \mu\text{F}$, $V_I = 14\text{V}$, $I_O = 10\text{mA}$, $V_{\text{INH}} = 0\text{V}$, unless otherwise specified).

Symbol	Parameter	Test conditions	Min.	Typ.	Max.	Unit
V_I	Maximum operating input voltage	$I_O = 10 \text{ mA}$, $T_J = -40 \text{ to } 125^\circ\text{C}$	26	37		V
V_O	Output voltage		3.135	3.3	3.425	V
V_O	Output voltage	$I_O = 100 \text{ mA}$, $V_I = 6 \text{ to } 26 \text{ V}$ $T_J = -40 \text{ to } 125^\circ\text{C}$	3.135	3.3	3.465	V
ΔV_O	Line regulation	$V_I = 9 \text{ to } 16 \text{ V}$		2	10	mV
		$V_I = 6 \text{ to } 26 \text{ V}$		4	33	
ΔV_O	Load regulation	$I_O = 5 \text{ to } 100 \text{ mA}$		10	33	mV
V_d	Dropout voltage ⁽¹⁾ ⁽²⁾	$I_O = 10 \text{ mA}$		90	250	mV
		$I_O = 100 \text{ mA}$		250	600	
I_d	Quiescent current ON MODE	$I_O = 100 \text{ mA}$		2.5	30	mA
	OFF MODE	$V_{\text{INH}} = 2.5 \text{ V}$, $R_{\text{LOAD}} = 330 \Omega$		0.3	1	mA
I_{SC}	Short circuit current		100	300		mA
SVR	Supply voltage rejection	$I_O = 100 \text{ mA}$, $V_I = 14 \pm 2 \text{ V}$ $f = 120 \text{ Hz}$, $T_J = -40 \text{ to } 125^\circ\text{C}$	55	78		dB
V_{IL}	Control input voltage low	$T_J = -40 \text{ to } 125^\circ\text{C}$		2	1.2	V
V_{IH}	Control input voltage high	$T_J = -40 \text{ to } 125^\circ\text{C}$	3.25	2		V
I_{INH}	Inhibit input current	$V_{\text{INH}} = 2.5 \text{ V}$		22	50	μA
V_I	Transient input voltage	$R_{\text{LOAD}} = 330 \Omega$, $\tau < 100\text{ms}$	60	70		V
V_I	Reverse polarity input voltage	$V_O = \pm 0.3 \text{ V}$, $R_{\text{LOAD}} = 330 \Omega$	-15	-50		V
V_I	Reverse polarity input voltage transient	$R_{\text{LOAD}} = 330 \Omega$, $\tau < 100\text{ms}$	-50			V
eN	Output noise voltage	$B = 10 \text{ Hz to } 100 \text{ KHz}$		330		μV_{RMS}

1. Reference Voltage is measured from V_{OUT} to ADJ pin.

2. V_d measured when the output voltage has dropped 100mV from the nominal value obtained at 14V.

Table 5. Electrical characteristics of LM2931B 3.3V (refer to the test circuits, $T_J = 25^\circ\text{C}$, $C_I = 0.1 \mu\text{F}$, $C_O = 100 \mu\text{F}$, $V_I = 14\text{V}$, $I_O = 10\text{mA}$, $V_{\text{INH}} = 0\text{V}$, unless otherwise specified).

Symbol	Parameter	Test conditions	Min.	Typ.	Max.	Unit
V_I	Maximum operating input voltage	$I_O = 10 \text{ mA}$, $T_J = -40 \text{ to } 125^\circ\text{C}$	26	37		V
V_O	Output voltage		3.135	3.3	3.465	V
V_O	Output voltage	$I_O = 100 \text{ mA}$, $V_I = 6 \text{ to } 26 \text{ V}$ $T_J = -40 \text{ to } 125^\circ\text{C}$	2.97	3.3	3.63	V
ΔV_O	Line regulation	$V_I = 9 \text{ to } 16 \text{ V}$		2	10	mV
		$V_I = 6 \text{ to } 26 \text{ V}$		4	33	
ΔV_O	Load regulation	$I_O = 5 \text{ to } 100 \text{ mA}$		10	33	mV
V_d	Dropout voltage ⁽¹⁾ ⁽²⁾	$I_O = 10 \text{ mA}$		90	200	mV
		$I_O = 100 \text{ mA}$		250	600	
I_d	Quiescent current ON MODE	$I_O = 100 \text{ mA}$		2.5	30	mA
	OFF MODE	$V_{\text{INH}} = 2.5 \text{ V}$, $R_{\text{LOAD}} = 330 \Omega$		0.3	1	mA
I_{SC}	Short circuit current		100	300		mA
SVR	Supply voltage rejection	$I_O = 100 \text{ mA}$, $V_I = 14 \pm 2 \text{ V}$ $f = 120 \text{ Hz}$, $T_J = -40 \text{ to } 125^\circ\text{C}$	55	78		dB
V_{IL}	Control input voltage low	$T_J = -40 \text{ to } 125^\circ\text{C}$		2	1.2	V
V_{IH}	Control input voltage high	$T_J = -40 \text{ to } 125^\circ\text{C}$	3.25	2		V
I_{INH}	Inhibit input current	$V_{\text{INH}} = 2.5 \text{ V}$		22	50	μA
V_I	Transient input voltage	$R_{\text{LOAD}} = 330 \Omega$, $\tau < 100\text{ms}$	60	70		V
V_I	Reverse polarity input voltage	$V_O = \pm 0.3 \text{ V}$, $R_{\text{LOAD}} = 330 \Omega$	-15	-50		V
V_I	Reverse polarity input voltage transient	$R_{\text{LOAD}} = 330 \Omega$, $\tau < 100\text{ms}$	-50			V
eN	Output noise voltage	$B = 10 \text{ Hz to } 100 \text{ KHz}$		330		μV_{RMS}

1. Reference Voltage is measured from V_{OUT} to ADJ pin.

2. V_d measured when the output voltage has dropped 100mV from the nominal value obtained at 14V.

Table 6. Electrical characteristics of LM2931A 5V (refer to the test circuits, $T_J = 25^\circ\text{C}$, $C_1 = 0.1 \mu\text{F}$, $C_O = 100 \mu\text{F}$, $V_I = 14\text{V}$, $I_O = 10\text{mA}$, $V_{\text{INH}} = 0\text{V}$, unless otherwise specified).

Symbol	Parameter	Test conditions	Min.	Typ.	Max.	Unit
V_I	Maximum operating input voltage	$I_O = 10 \text{ mA}$, $T_J = -40 \text{ to } 125^\circ\text{C}$	26	37		V
V_O	Output voltage		4.81	5	5.19	V
V_O	Output voltage	$I_O = 100 \text{ mA}$, $V_I = 6 \text{ to } 26 \text{ V}$ $T_J = -40 \text{ to } 125^\circ\text{C}$	4.75	5	5.25	V
ΔV_O	Line regulation	$V_I = 9 \text{ to } 16 \text{ V}$		2	10	mV
		$V_I = 6 \text{ to } 26 \text{ V}$		4	30	
ΔV_O	Load regulation	$I_O = 5 \text{ to } 100 \text{ mA}$		15	50	mV
V_d	Dropout voltage ⁽¹⁾ ⁽²⁾	$I_O = 10 \text{ mA}$		90	200	mV
		$I_O = 100 \text{ mA}$		250	600	
I_d	Quiescent current ON MODE	$I_O = 100 \text{ mA}$		2.5	30	mA
	OFF MODE	$V_{\text{INH}} = 2.5 \text{ V}$, $R_{\text{LOAD}} = 500 \Omega$		0.3	1	mA
I_{SC}	Short circuit current		100	300		mA
SVR	Supply voltage rejection	$I_O = 100 \text{ mA}$, $V_I = 14 \pm 2 \text{ V}$ $f = 120 \text{ Hz}$, $T_J = -40 \text{ to } 125^\circ\text{C}$	55	75		dB
V_{IL}	Control input voltage low	$T_J = -40 \text{ to } 125^\circ\text{C}$		2	1.2	V
V_{IH}	Control input voltage high	$T_J = -40 \text{ to } 125^\circ\text{C}$	3.25	2		V
I_{INH}	Inhibit input current	$V_{\text{INH}} = 2.5 \text{ V}$		22	50	μA
V_I	Transient input voltage	$R_{\text{LOAD}} = 500 \Omega$, $\tau < 100\text{ms}$	60	70		V
V_I	Reverse polarity input voltage	$V_O = \pm 0.3 \text{ V}$, $R_{\text{LOAD}} = 500 \Omega$	-15	-50		V
V_I	Reverse polarity input voltage transient	$R_{\text{LOAD}} = 500 \Omega$, $\tau < 100\text{ms}$	-50			V
eN	Output noise voltage	$B = 10 \text{ Hz to } 100 \text{ KHz}$		500		μV_{RMS}

1. Reference Voltage is measured from V_{OUT} to ADJ pin.

2. V_d measured when the output voltage has dropped 100mV from the nominal value obtained at 14V.

Table 7. Electrical characteristics of LM2931B 5V (refer to the test circuits, $T_J = 25^\circ\text{C}$, $C_1 = 0.1 \mu\text{F}$, $C_O = 100 \mu\text{F}$, $V_I = 14\text{V}$, $I_O = 10\text{mA}$, $V_{\text{INH}} = 0\text{V}$, unless otherwise specified).

Symbol	Parameter	Test conditions	Min.	Typ.	Max.	Unit
V_I	Maximum operating input voltage	$I_O = 10 \text{ mA}$, $T_J = -40 \text{ to } 125^\circ\text{C}$	26	37		V
V_O	Output voltage		4.75	5	5.25	V
V_O	Output voltage	$I_O = 100 \text{ mA}$, $V_I = 6 \text{ to } 26 \text{ V}$ $T_J = -40 \text{ to } 125^\circ\text{C}$	4.5	5	5.5	V
ΔV_O	Line regulation	$V_I = 9 \text{ to } 16 \text{ V}$		2	10	mV
		$V_I = 6 \text{ to } 26 \text{ V}$		4	30	
ΔV_O	Load regulation	$I_O = 5 \text{ to } 100 \text{ mA}$		15	50	mV
V_d	Dropout voltage ⁽¹⁾ ⁽²⁾	$I_O = 10 \text{ mA}$		90	200	mV
		$I_O = 100 \text{ mA}$		250	600	
I_d	Quiescent current ON MODE	$I_O = 100 \text{ mA}$		2.5	30	mA
	OFF MODE	$V_{\text{INH}} = 2.5 \text{ V}$, $R_{\text{LOAD}} = 500 \Omega$		0.3	1	mA
I_{SC}	Short circuit current		100	300		mA
SVR	Supply voltage rejection	$I_O = 100 \text{ mA}$, $V_I = 14 \pm 2 \text{ V}$ $f = 120 \text{ Hz}$, $T_J = -40 \text{ to } 125^\circ\text{C}$	55	75		dB
V_{IL}	Control input voltage low	$T_J = -40 \text{ to } 125^\circ\text{C}$		2	1.2	V
V_{IH}	Control input voltage high	$T_J = -40 \text{ to } 125^\circ\text{C}$	3.25	2		V
I_{INH}	Inhibit input current	$V_{\text{INH}} = 2.5 \text{ V}$		22	50	μA
V_I	Transient input voltage	$R_{\text{LOAD}} = 500 \Omega$, $\tau < 100\text{ms}$	60	70		V
V_I	Reverse polarity input voltage	$V_O = \pm 0.3 \text{ V}$, $R_{\text{LOAD}} = 500 \Omega$	-15	-50		V
V_I	Reverse polarity input voltage transient	$R_{\text{LOAD}} = 500 \Omega$, $\tau < 100\text{ms}$	-50			V
eN	Output noise voltage	$B = 10 \text{ Hz to } 100 \text{ KHz}$		500		μV_{RMS}

1. Reference Voltage is measured from V_{OUT} to ADJ pin.

2. V_d measured when the output voltage has dropped 100mV from the nominal value obtained at 14V.

Table 8. Electrical characteristics of LM2931ADJ (refer to the test circuits figure 2 with $R_1 = 27k\Omega$ and $R_2 = 40.5k\Omega$, $T_J = 25^\circ\text{C}$, $C_1 = 0.1 \mu\text{F}$, $C_O = 100 \mu\text{F}$, $V_I = 14\text{V}$, $I_O = 10\text{mA}$, $V_{INH} = 0\text{V}$, unless otherwise specified).

Symbol	Parameter	Test conditions	Min.	Typ.	Max.	Unit
V_I	Maximum Operating Input Voltage	$I_O = 10 \text{ mA}$, $T_J = -40 \text{ to } 125^\circ\text{C}$	26	37		V
V_{REF}	Reference Voltage ⁽¹⁾		1.14	1.2	1.26	V
V_{REF}	Reference Voltage ⁽¹⁾	$I_O = 100 \text{ mA}$, $T_J = -40 \text{ to } 125^\circ\text{C}$	1.08	1.2	1.32	V
ΔV_O	Line Regulation	$V_I = 3.6 \text{ to } 26 \text{ V}$		0.6	4.5	mV
ΔV_O	Load Regulation	$I_O = 5 \text{ to } 100 \text{ mA}$		9	30	mV
V_d	Dropout Voltage ^{(1) (2)}	$I_O = 10 \text{ mA}$		90	200	mV
		$I_O = 100 \text{ mA}$		250	600	
I_d	Quiescent Current ON MODE	$I_O = 100 \text{ mA}$		2.5	30	mA
	OFF MODE	$V_{INH} = 2.5 \text{ V}$, $R_{LOAD} = 300 \Omega$		0.3	1	mA
I_{SC}	Short Circuit Current		100	300		mA
SVR	Supply Voltage Rejection	$I_O = 100 \text{ mA}$, $V_I = 14 \pm 2 \text{ V}$ $f = 120 \text{ Hz}$, $T_J = -40 \text{ to } 125^\circ\text{C}$	55	80		dB
V_{IL}	Control Input Voltage Low	$T_J = -40 \text{ to } 125^\circ\text{C}$		2	1.2	V
V_{IH}	Control Input Voltage High	$T_J = -40 \text{ to } 125^\circ\text{C}$	3.25	2		V
I_{INH}	Inhibit Input Current	$V_{INH} = 2.5 \text{ V}$		22	50	μA
V_I	Transient Input Voltage	$R_{LOAD} = 300 \Omega$, $\tau < 100\text{ms}$	60	70		V
V_I	Reverse Polarity Input Voltage	$V_O = \pm 0.3 \text{ V}$, $R_{LOAD} = 300 \Omega$	-15	-50		V
V_I	Reverse Polarity Input Voltage Transient	$R_{LOAD} = 300 \Omega$, $\tau < 100\text{ms}$	-50			V
eN	Output Noise Voltage	B = 10 Hz to 100 KHz		330		μV_{RMS}

1. Reference Voltage is measured from V_{OUT} to ADJ pin.

2. V_d measured when the output voltage has dropped 100mV from the nominal value obtained at 14V.

6 Typical characteristics

(unless otherwise specified $C_I = 0.1 \mu\text{F}$, $C_O = 100 \mu\text{F}$)

Figure 5. Output voltage vs temperature

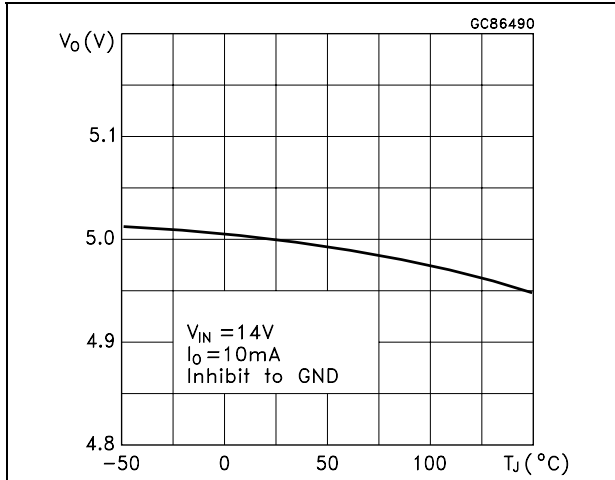

Figure 6. Output voltage vs temperature

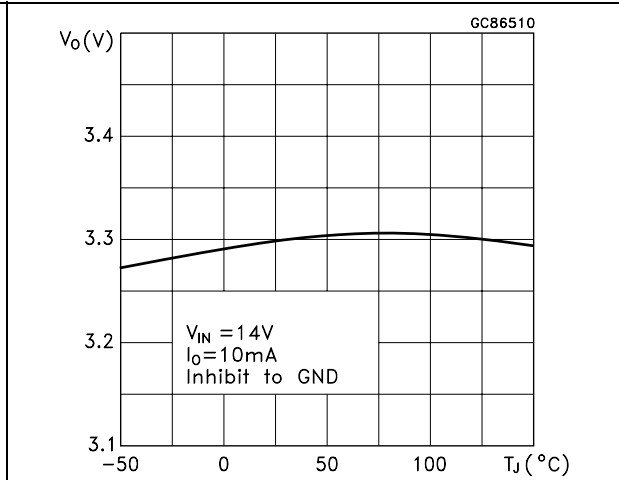

Figure 7. Reference voltage vs temperature

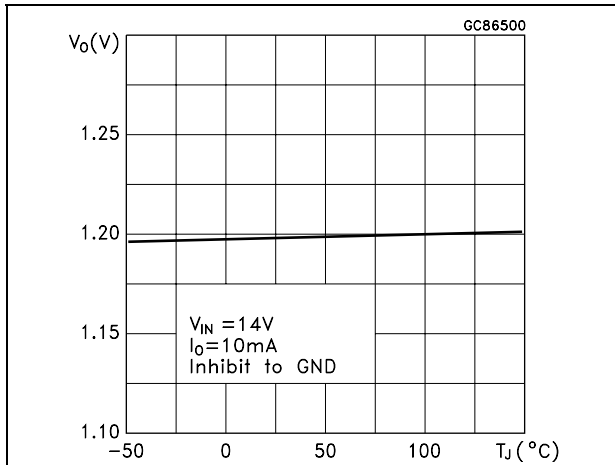

Figure 8. Line regulation vs temperature

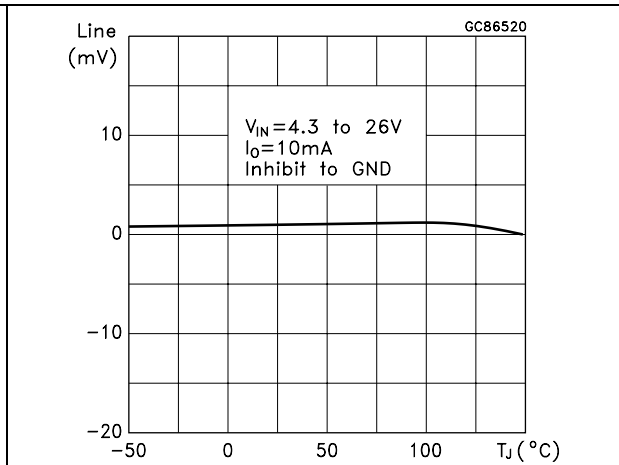

Figure 9. Load regulation vs temperature

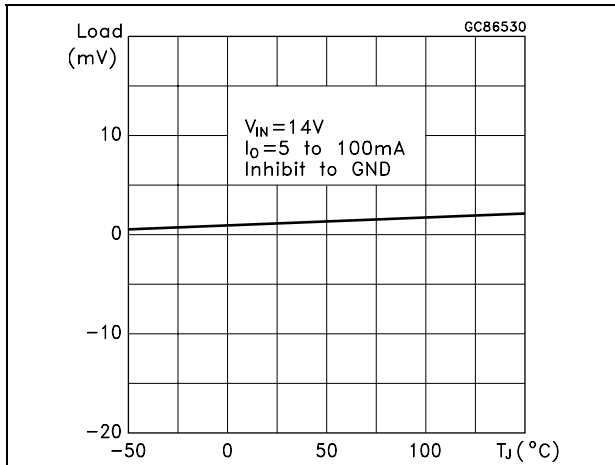

Figure 10. Dropout voltage vs temperature

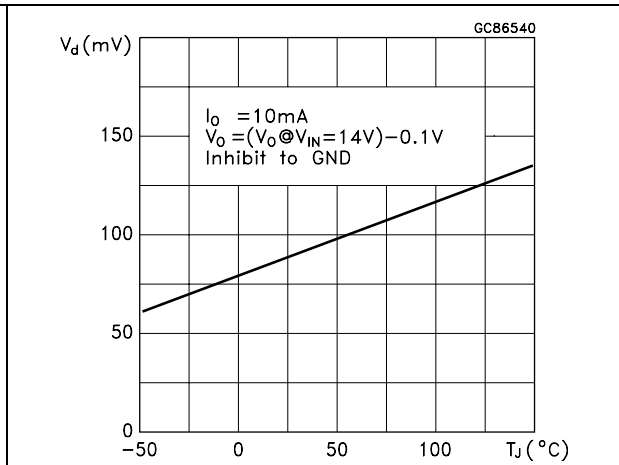

Figure 11. Dropout voltage vs temperature

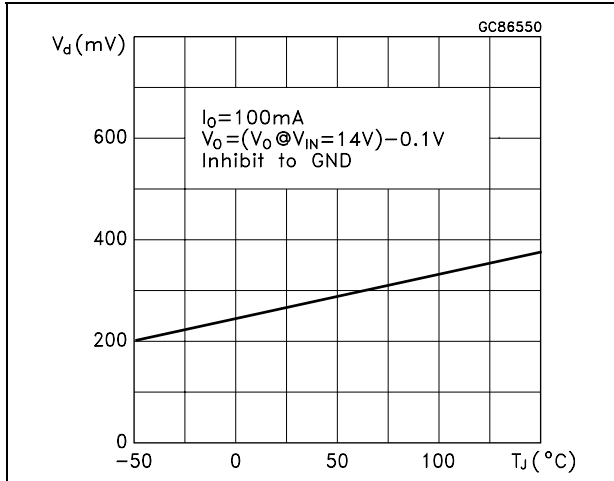

Figure 12. Dropout voltage vs output current

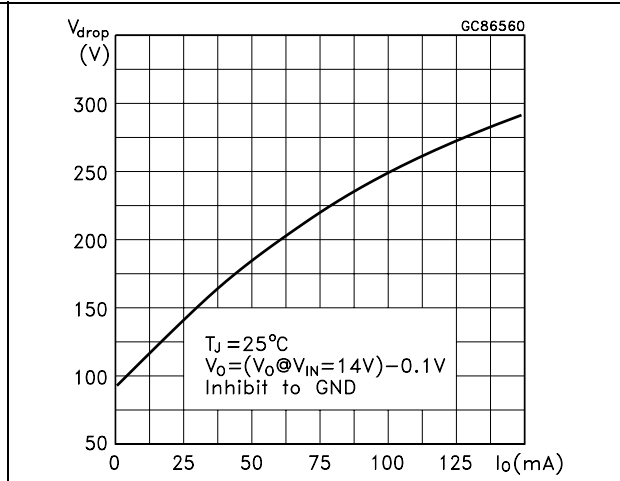

Figure 13. Output voltage vs input voltage

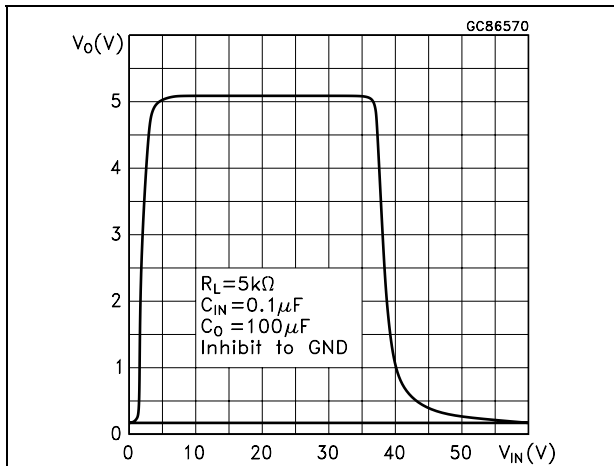

Figure 14. Short circuit current vs drop voltage

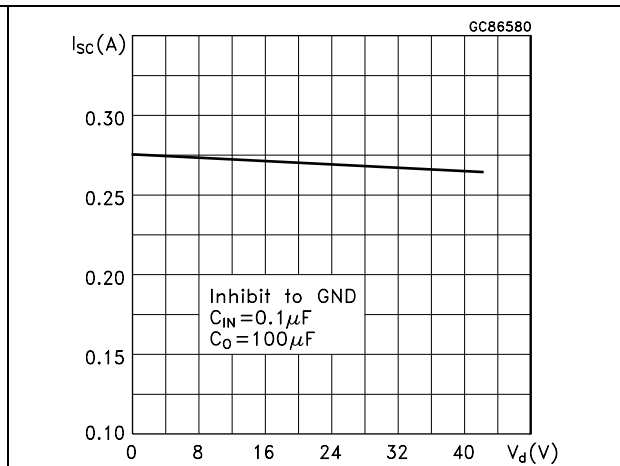

Figure 15. Quiescent current vs temperature

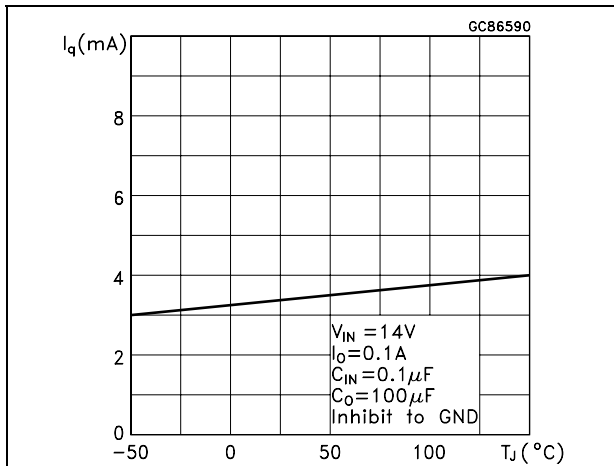

Figure 16. Quiescent current vs input voltage

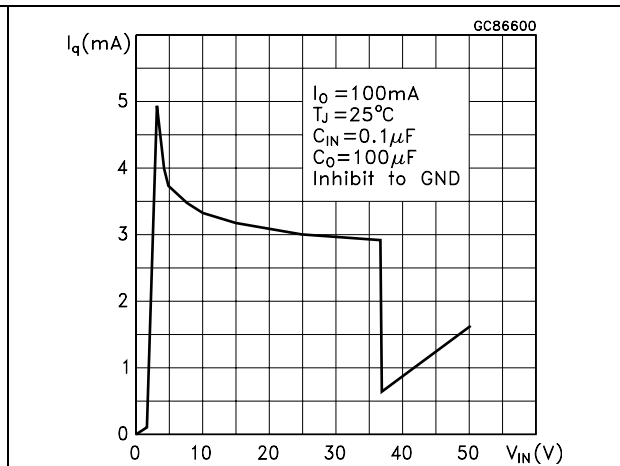

Figure 17. Quiescent current vs output current Figure 18. Supply voltage rejection vs temperature

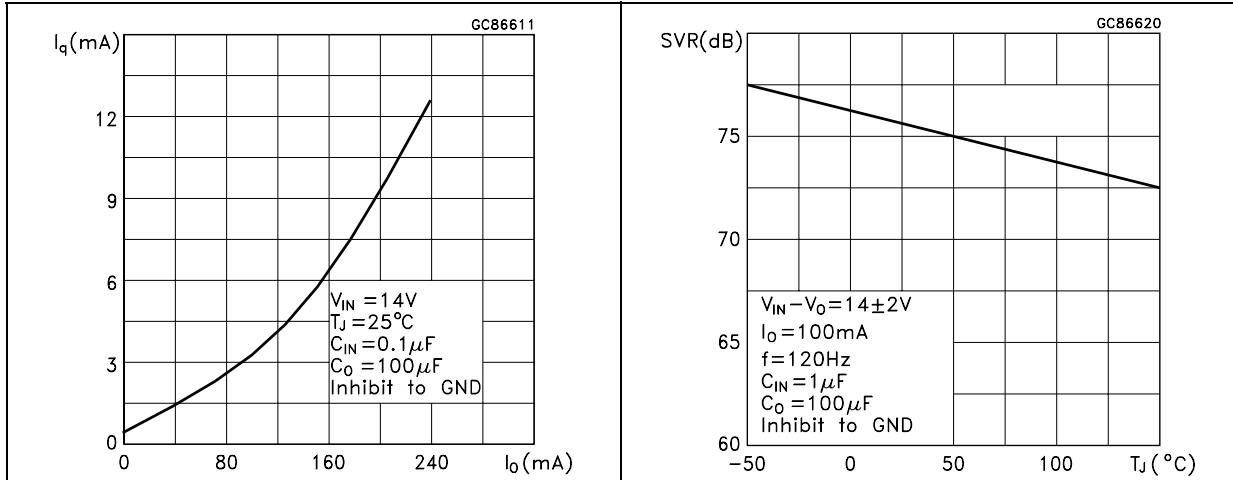

Figure 19. Supply voltage rejection vs frequency

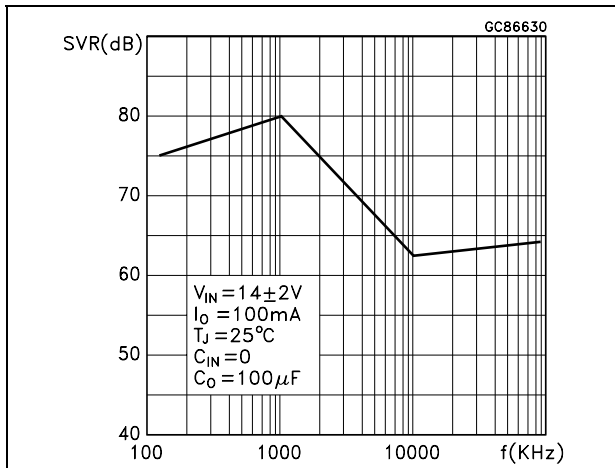

Figure 20. Supply voltage rejection vs output current

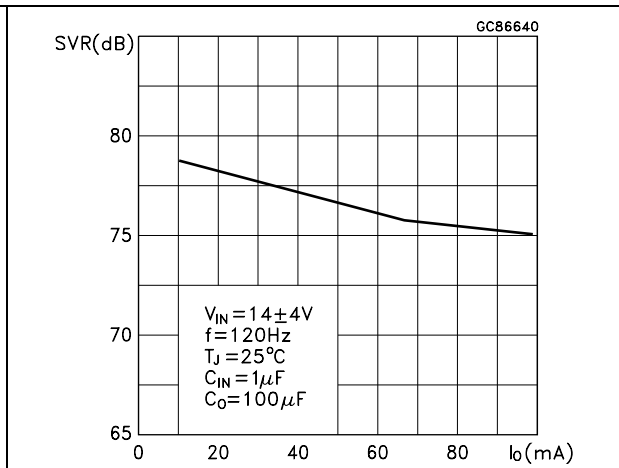

Figure 21. Stability vs C_O

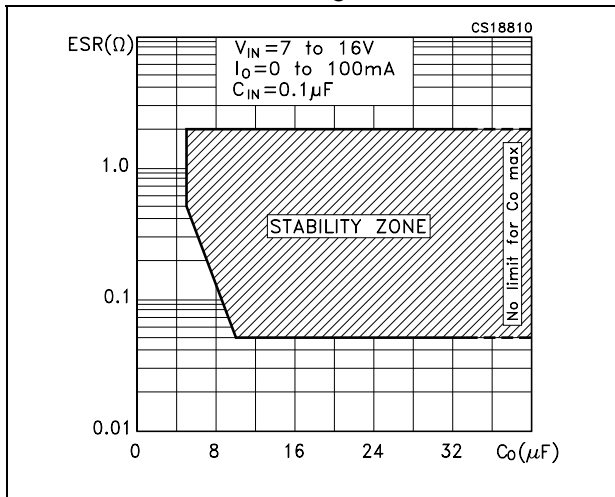

Figure 22. Line transient

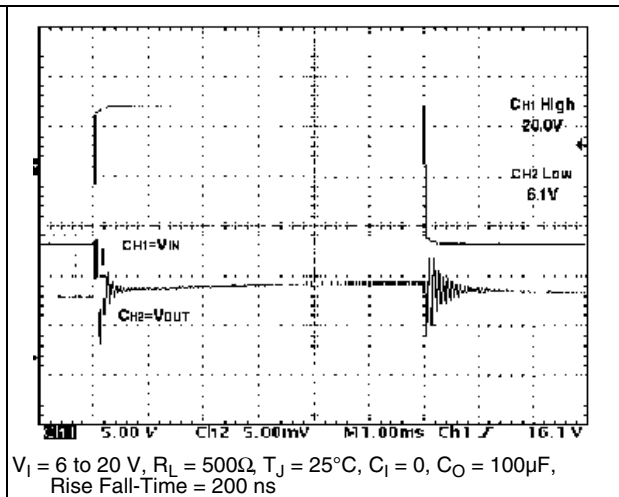
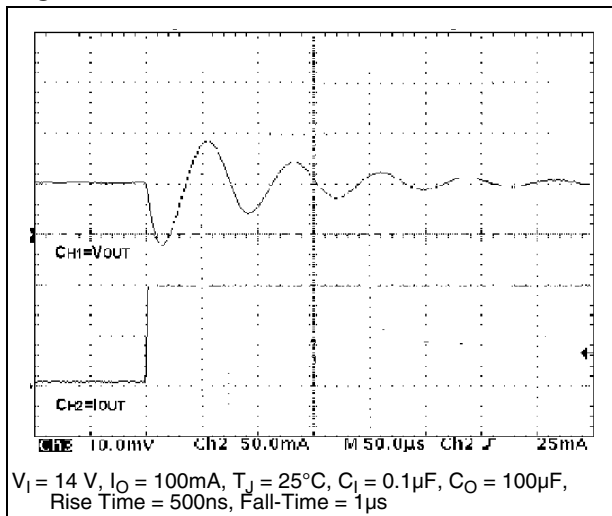

Figure 23. Line transient



7 Package mechanical data

In order to meet environmental requirements, ST offers these devices in ECOPACK® packages. These packages have a Lead-free second level interconnect. The category of second Level Interconnect is marked on the package and on the inner box label, in compliance with JEDEC Standard JESD97. The maximum ratings related to soldering conditions are also marked on the inner box label. ECOPACK is an ST trademark. ECOPACK specifications are available at: www.st.com.

TO-220 mechanical data

Dim.	mm.			inch.		
	Min.	Typ.	Max.	Min.	Typ.	Max.
A	4.40		4.60	0.173		0.181
C	1.23		1.32	0.048		0.051
D	2.40		2.72	0.094		0.107
D1		1.27			0.050	
E	0.49		0.70	0.019		0.027
F	0.61		0.88	0.024		0.034
F1	1.14		1.70	0.044		0.067
F2	1.14		1.70	0.044		0.067
G	4.95		5.15	0.194		0.203
G1	2.4		2.7	0.094		0.106
H2	10.0		10.40	0.393		0.409
L2		16.4			0.645	
L4	13.0		14.0	0.511		0.551
L5	2.65		2.95	0.104		0.116
L6	15.25		15.75	0.600		0.620
L7	6.2		6.6	0.244		0.260
L9	3.5		3.93	0.137		0.154
DIA.	3.75		3.85	0.147		0.151

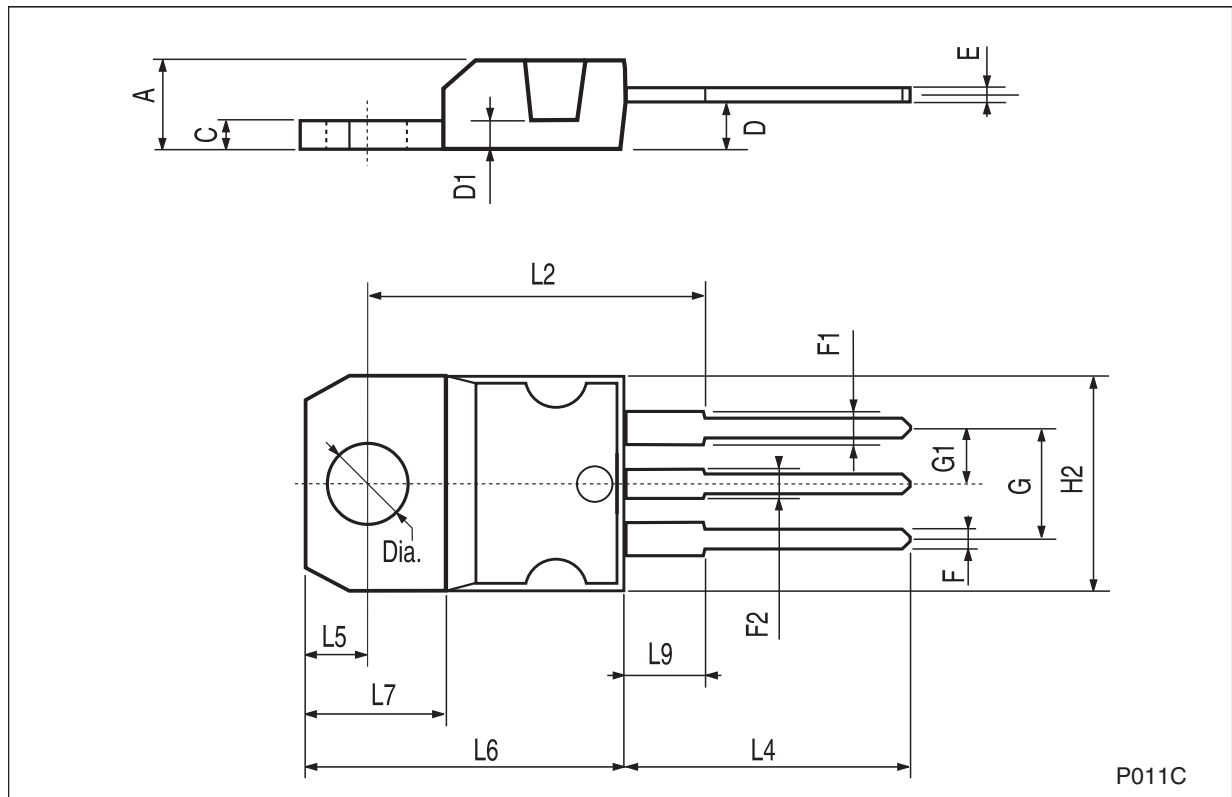

P011C

TO-92 mechanical data

Dim.	mm.			mils.		
	Min.	Typ.	Max.	Min.	Typ.	Max.
A	4.32		4.95	170.1		194.9
b	0.36		0.51	14.2		20.1
D	4.45		4.95	175.2		194.9
E	3.30		3.94	129.9		155.1
e	2.41		2.67	94.9		105.1
e1	1.14		1.40	44.9		55.1
L	12.7		15.49	500.0		609.8
R	2.16		2.41	85.0		94.9
S1	0.92		1.52	36.2		59.8
W	0.41		0.56	16.1		22.0
α		5°			5°	

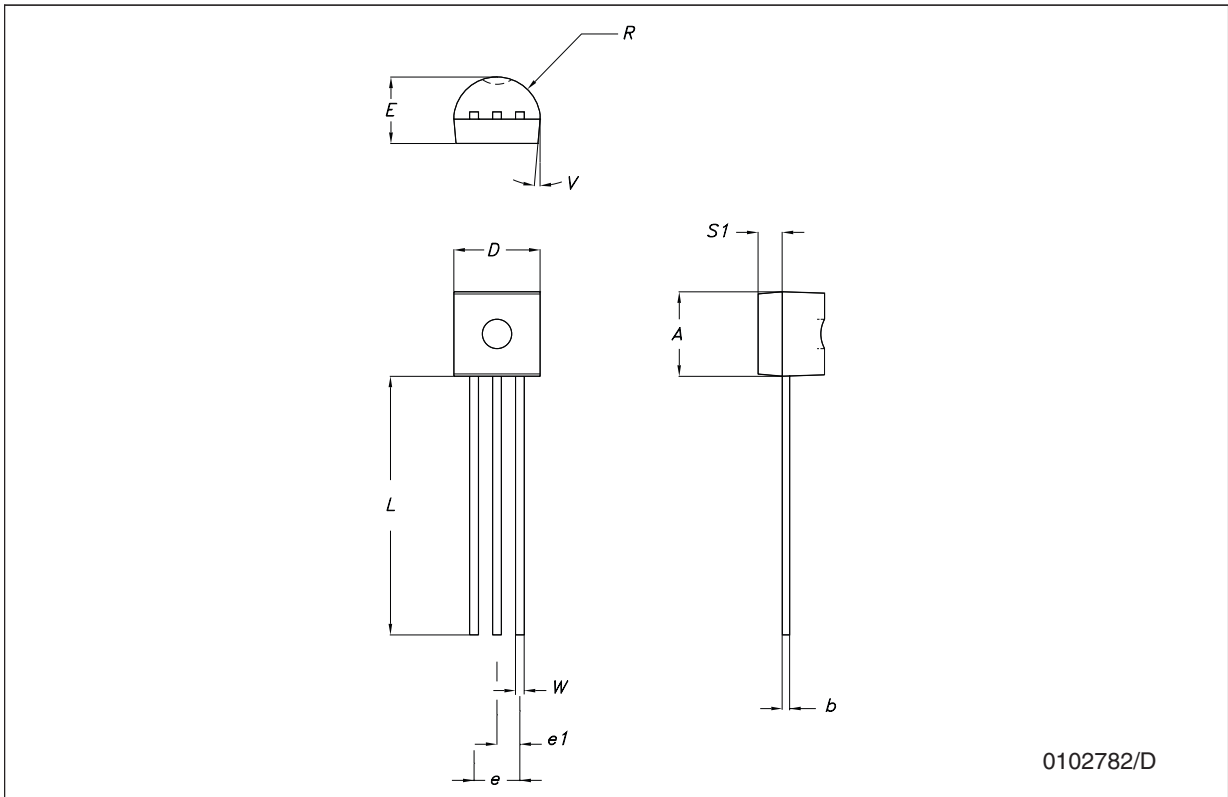

DPAK mechanical data

Dim.	mm.			inch.		
	Min.	Typ.	Max.	Min.	Typ.	Max.
A	2.2		2.4	0.086		0.094
A1	0.9		1.1	0.035		0.043
A2	0.03		0.23	0.001		0.009
B	0.64		0.9	0.025		0.035
b4	5.2		5.4	0.204		0.212
C	0.45		0.6	0.017		0.023
C2	0.48		0.6	0.019		0.023
D	6		6.2	0.236		0.244
D1		5.1			0.200	
E	6.4		6.6	0.252		0.260
E1		4.7			0.185	
e		2.28			0.090	
e1	4.4		4.6	0.173		0.181
H	9.35		10.1	0.368		0.397
L	1			0.039		
(L1)		2.8			0.110	
L2		0.8			0.031	
L4	0.6		1	0.023		0.039
R		0.2			0.008	
V2	0°		8°	0°		8°

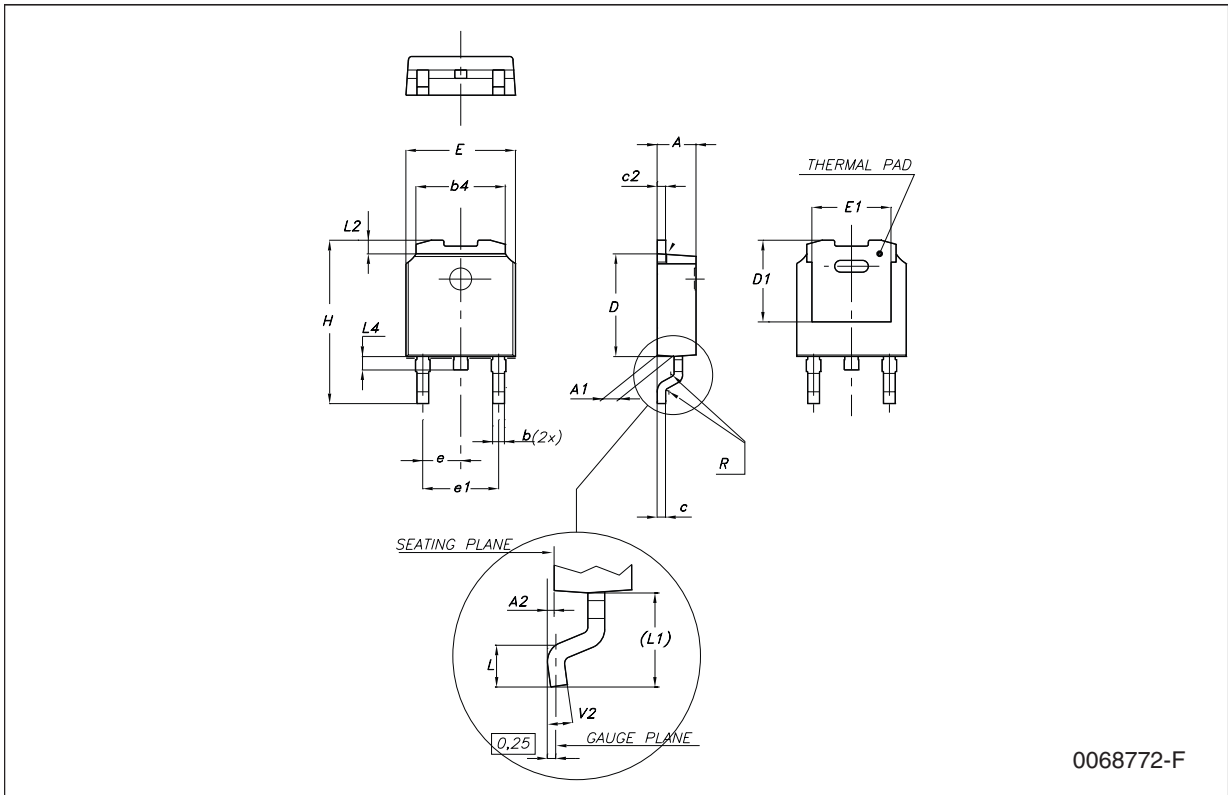

0068772-F

SO-8 mechanical data

Dim.	mm.			inch.		
	Min.	Typ.	Max.	Min.	Typ.	Max.
A	1.35		1.75	0.053		0.069
A1	0.10		0.25	0.04		0.010
A2	1.10		1.65	0.043		0.065
B	0.33		0.51	0.013		0.020
C	0.19		0.25	0.007		0.010
D	4.80		5.00	0.189		0.197
E	3.80		4.00	0.150		0.157
e		1.27			0.050	
H	5.80		6.20	0.228		0.244
h	0.25		0.50	0.010		0.020
L	0.40		1.27	0.016		0.050
k	8° (max.)					
ddd			0.1			0.04

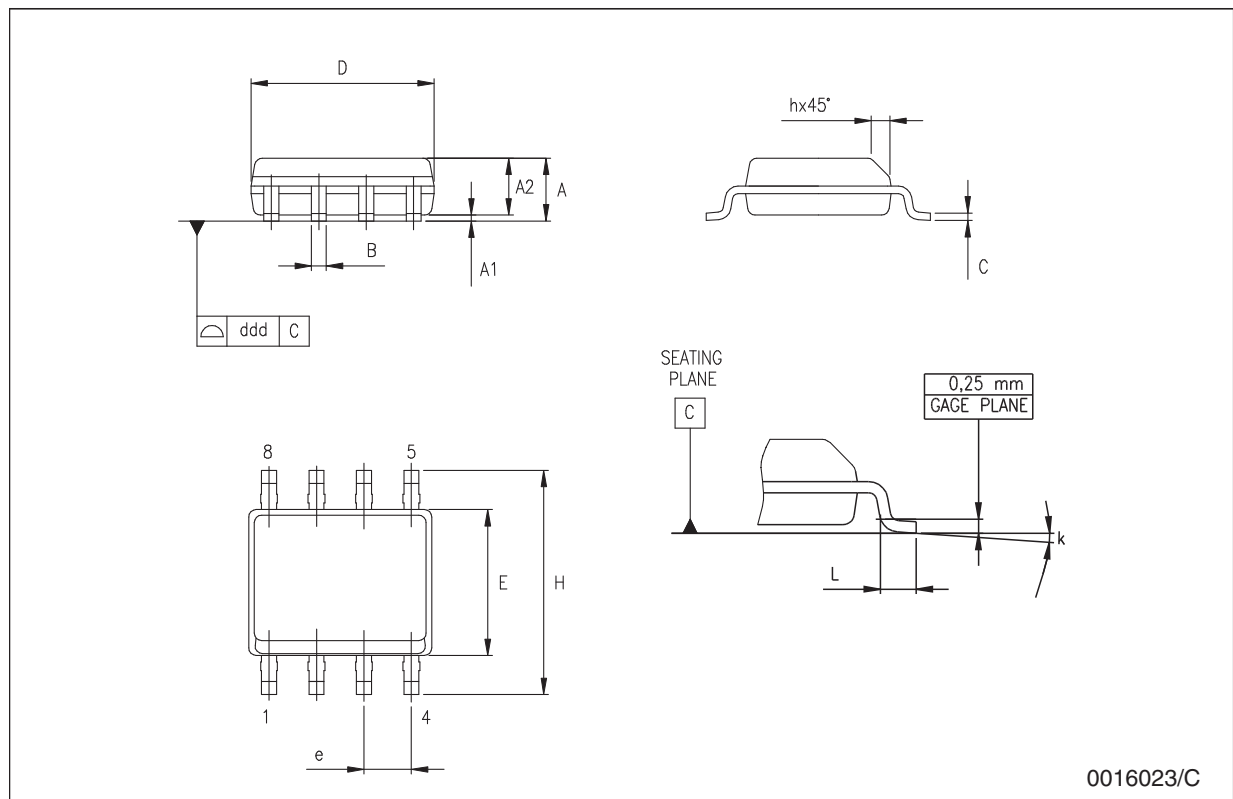

0016023/C

Tape & reel DPAK-PPAK mechanical data

Dim.	mm.			inch.		
	Min.	Typ.	Max.	Min.	Typ.	Max.
A			330			12.992
C	12.8	13.0	13.2	0.504	0.512	0.519
D	20.2			0.795		
N	60			2.362		
T			22.4			0.882
Ao	6.80	6.90	7.00	0.268	0.272	0.276
Bo	10.40	10.50	10.60	0.409	0.413	0.417
Ko	2.55	2.65	2.75	0.100	0.104	0.105
Po	3.9	4.0	4.1	0.153	0.157	0.161
P	7.9	8.0	8.1	0.311	0.315	0.319

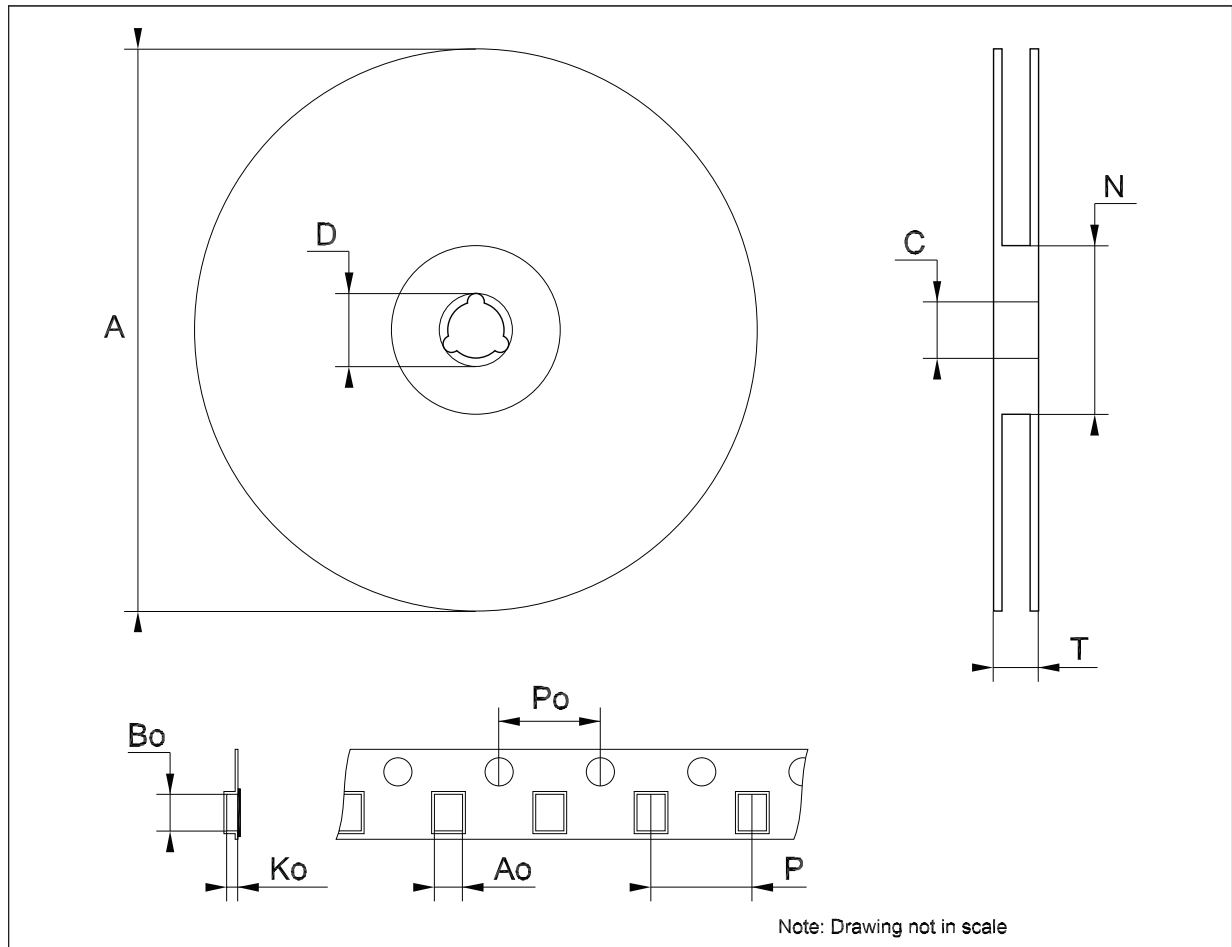

Tape & reel SO-8 mechanical data

Dim.	mm.			inch.		
	Min.	Typ.	Max.	Min.	Typ.	Max.
A			330			12.992
C	12.8		13.2	0.504		0.519
D	20.2			0.795		
N	60			2.362		
T			22.4			0.882
Ao	8.1		8.5	0.319		0.335
Bo	5.5		5.9	0.216		0.232
Ko	2.1		2.3	0.082		0.090
Po	3.9		4.1	0.153		0.161
P	7.9		8.1	0.311		0.319

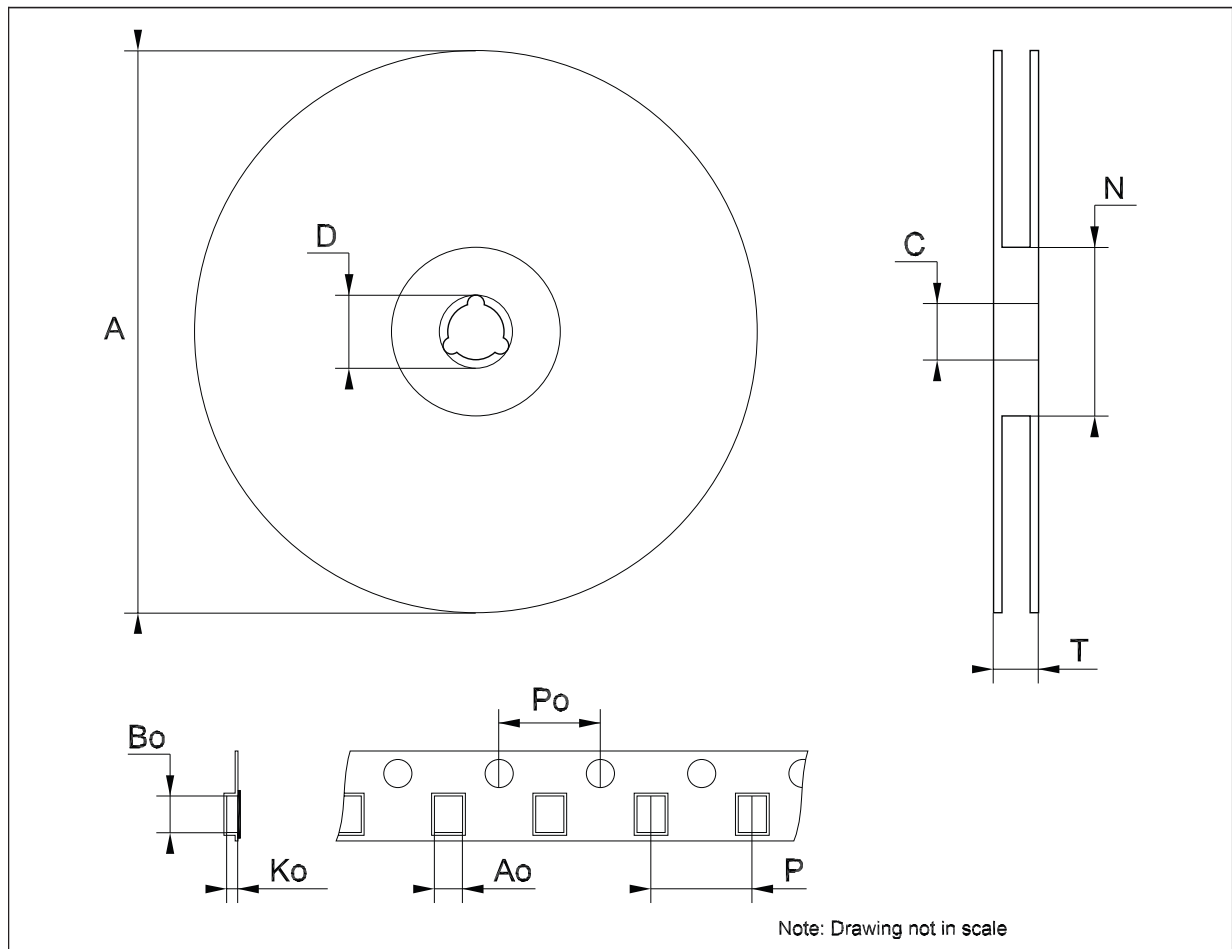

Tape & reel for TO-92 mechanical data

Dim.	mm.			inch.		
	Min.	Typ.	Max.	Min.	Typ.	Max.
A1		4.80			0.189	
T		3.80			0.150	
T1		1.60			0.063	
T2		2.30			0.091	
d		0.48			0.019	
P0	12.5		12.9	0.492		0.508
P2	5.65		7.05	0.222		0.278
F1, F2	2.44	2.54	2.94	0.096	0.100	0.116
delta H		±2			0.079	
W	17.5	18.00	19.0	0.689	0.709	0.748
W0	5.7		6.3	0.224		0.248
W1	8.5		9.25	0.335		0.364
W2		0.50			0.20	
H		18.50	18.70		0.728	0.726
H0	15.50		16.50	0.610		0.650
H1		25.00			0.984	
D0	3.8		4.2	0.150		0.165
t		0.90			0.035	
L1		3			0.118	
delta P		±1			0.039	
u		50			1.968	
Φ1		360			14.173	
Φ2		30			1.181	

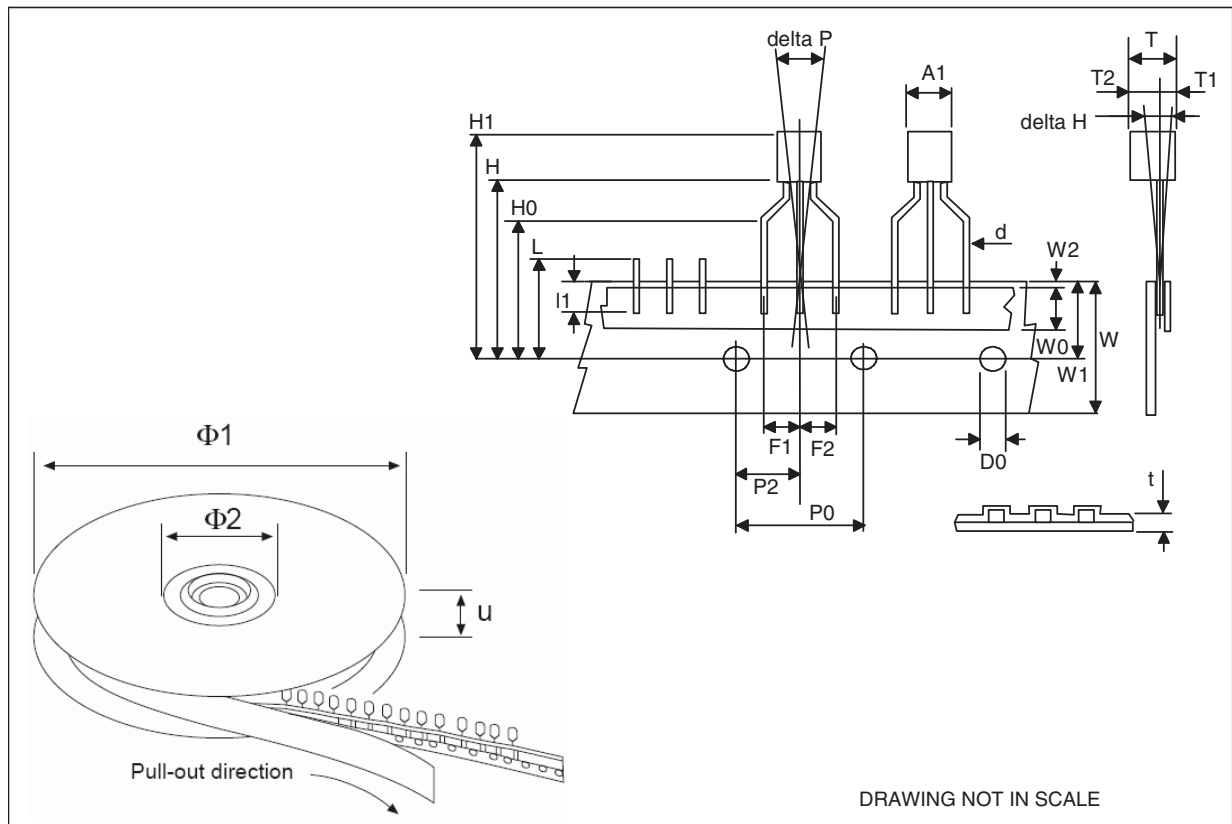

8 Order codes

Table 9. Order codes

Packages					Output voltage
TO-220	DPAK	TO-92 (BAG)	TO-92 (Ammopak) ⁽¹⁾	SO-8	
		LM2931AZ33R		LM2931AD33R	3.3 V
LM2931AV50	LM2931ADT50R	LM2931AZ50R	LM2931AD50AP	LM2931AD50R	5.0 V
LM2931BV50	LM2931BDT50R	LM2931BZ50R	LM2931BD50AP	LM2931BD50R	5.0 V
				LM2931D-R	2.5 to 26 V

1. Please note that in these cases pins are shaped according to Tape & Reel specifications.

9 Revision history

Table 10. Revision history

Date	Revision	Changes
21-Jun-2004	12	Document updating.
16-Jun-2006	13	Order codes updated and the document has been reformatted.
27-Jul-2007	14	Add Table 1 in cover page.

Please Read Carefully:

Information in this document is provided solely in connection with ST products. STMicroelectronics NV and its subsidiaries ("ST") reserve the right to make changes, corrections, modifications or improvements, to this document, and the products and services described herein at any time, without notice.

All ST products are sold pursuant to ST's terms and conditions of sale.

Purchasers are solely responsible for the choice, selection and use of the ST products and services described herein, and ST assumes no liability whatsoever relating to the choice, selection or use of the ST products and services described herein.

No license, express or implied, by estoppel or otherwise, to any intellectual property rights is granted under this document. If any part of this document refers to any third party products or services it shall not be deemed a license grant by ST for the use of such third party products or services, or any intellectual property contained therein or considered as a warranty covering the use in any manner whatsoever of such third party products or services or any intellectual property contained therein.

UNLESS OTHERWISE SET FORTH IN ST'S TERMS AND CONDITIONS OF SALE ST DISCLAIMS ANY EXPRESS OR IMPLIED WARRANTY WITH RESPECT TO THE USE AND/OR SALE OF ST PRODUCTS INCLUDING WITHOUT LIMITATION IMPLIED WARRANTIES OF MERCHANTABILITY, FITNESS FOR A PARTICULAR PURPOSE (AND THEIR EQUIVALENTS UNDER THE LAWS OF ANY JURISDICTION), OR INFRINGEMENT OF ANY PATENT, COPYRIGHT OR OTHER INTELLECTUAL PROPERTY RIGHT.

UNLESS EXPRESSLY APPROVED IN WRITING BY AN AUTHORIZED ST REPRESENTATIVE, ST PRODUCTS ARE NOT RECOMMENDED, AUTHORIZED OR WARRANTED FOR USE IN MILITARY, AIR CRAFT, SPACE, LIFE SAVING, OR LIFE SUSTAINING APPLICATIONS, NOR IN PRODUCTS OR SYSTEMS WHERE FAILURE OR MALFUNCTION MAY RESULT IN PERSONAL INJURY, DEATH, OR SEVERE PROPERTY OR ENVIRONMENTAL DAMAGE. ST PRODUCTS WHICH ARE NOT SPECIFIED AS "AUTOMOTIVE GRADE" MAY ONLY BE USED IN AUTOMOTIVE APPLICATIONS AT USER'S OWN RISK.

Resale of ST products with provisions different from the statements and/or technical features set forth in this document shall immediately void any warranty granted by ST for the ST product or service described herein and shall not create or extend in any manner whatsoever, any liability of ST.

ST and the ST logo are trademarks or registered trademarks of ST in various countries.

Information in this document supersedes and replaces all information previously supplied.

The ST logo is a registered trademark of STMicroelectronics. All other names are the property of their respective owners.

© 2007 STMicroelectronics - All rights reserved

STMicroelectronics group of companies

Australia - Belgium - Brazil - Canada - China - Czech Republic - Finland - France - Germany - Hong Kong - India - Israel - Italy - Japan - Malaysia - Malta - Morocco - Singapore - Spain - Sweden - Switzerland - United Kingdom - United States of America

www.st.com