

LM2665 Switched Capacitor Voltage Converter

1 Features

- Input Voltage for Voltage Doubler: 2.5 V to 5.5 V
- Voltage Divider Splits Voltage: 1.8 V to 11 V
- Doubles or Splits Input Supply Voltage
- 12- Ω Typical Output Impedance
- 90% Typical Conversion Efficiency at 40 mA
- 1- μ A Typical Shutdown Current

2 Applications

- Cellular Phones
- Pagers
- PDAs
- Operational Amplifier Power Suppliers
- Interface Power Suppliers
- Handheld Instruments
- Fire Detection and Notification
- Industrial Handheld Radios
- Blood Pressure Monitors

3 Description

The LM2665 CMOS charge-pump voltage converter operates as a voltage doubler for an input voltage in the range of 2.5 V to 5.5 V. Two low-cost capacitors and a diode (needed during start-up) are used in this circuit to provide up to 40 mA of output current. The LM2665 can also work as a voltage divider to split a voltage in the range of 1.8 V to 11 V in half.

The LM2665 operates at 160-kHz oscillator frequency to reduce output resistance and voltage ripple. With an operating current of only 650 μ A (operating efficiency greater than 90% with most loads) and 1- μ A typical shutdown current, the LM2665 provides ideal performance for battery powered systems.

Device Information⁽¹⁾

PART NUMBER	PACKAGE	BODY SIZE (NOM)
LM2665	SOT-23 (6)	2.90 mm x 1.60 mm

(1) For all available packages, see the orderable addendum at the end of the data sheet.

Voltage Doubler

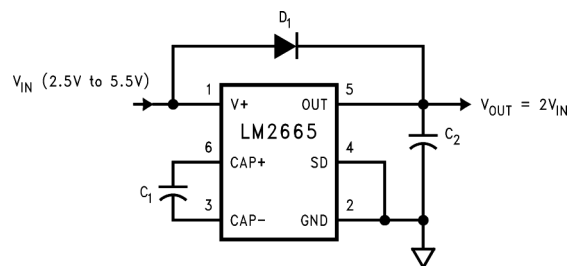

Splitting V_{in} in Half

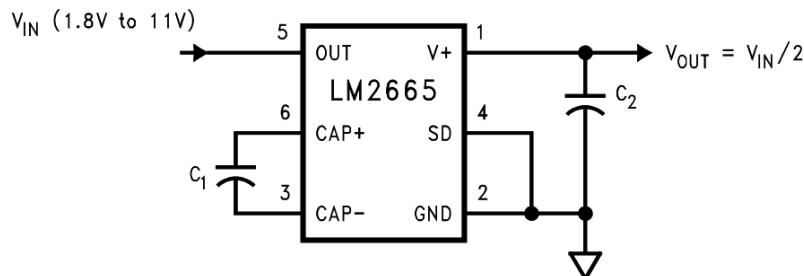

Table of Contents

1 Features 1 2 Applications 1 3 Description 1 4 Revision History 2 5 Pin Configuration and Functions 3 6 Specifications 4 6.1 Absolute Maximum Ratings 4 6.2 ESD Ratings 4 6.3 Recommended Operating Conditions 4 6.4 Thermal Information 4 6.5 Electrical Characteristics 5 6.6 Typical Characteristics 5 7 Parameter Measurement Information 7 7.1 Test Circuit 7 8 Detailed Description 8 8.1 Overview 8	8.2 Functional Block Diagram 8 8.3 Feature Description 8 8.4 Device Functional Modes 8 9 Application and Implementation 9 9.1 Application Information 9 9.2 Typical Applications 9 10 Power Supply Recommendations 12 11 Layout 13 11.1 Layout Guidelines 13 11.2 Layout Example 13 12 Device and Documentation Support 14 12.1 Community Resources 14 12.2 Trademarks 14 12.3 Electrostatic Discharge Caution 14 12.4 Glossary 14 13 Mechanical, Packaging, and Orderable Information 14
--	---

4 Revision History

NOTE: Page numbers for previous revisions may differ from page numbers in the current version.

Changes from Revision G (July 2015) to Revision H	Page
---	------

- | | |
|--|---|
| • Added several new "Applications" to page 1 | 1 |
|--|---|

Changes from Revision F (May 2013) to Revision G	Page
--	------

- | | |
|---|---|
| • Added <i>Pin Configuration and Functions</i> section, <i>ESD Rating</i> table, <i>Feature Description</i> , <i>Device Functional Modes</i> , <i>Application and Implementation</i> , <i>Power Supply Recommendations</i> , <i>Layout</i> , <i>Device and Documentation Support</i> , and <i>Mechanical, Packaging, and Orderable Information</i> sections | 1 |
|---|---|

Changes from Revision E (May 2013) to Revision F	Page
--	------

- | | |
|--|----|
| • Changed layout of National Data Sheet to TI format | 12 |
|--|----|

5 Pin Configuration and Functions

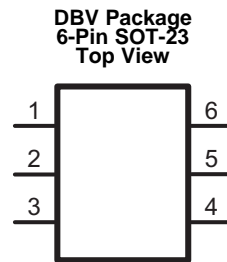

Pin Functions

PIN		TYPE	DESCRIPTION	
NO.	NAME		VOLTAGE DOUBLER	VOLTAGE SPLIT
1	V+	Power	Power supply positive voltage input	Positive voltage output
2	GND	Ground	Power supply ground input	Same as doubler
3	CAP-	Power	Connect this pin to the negative terminal of the charge-pump capacitor.	Same as doubler
4	SD	Input	Shutdown control pin, tie this pin to ground in normal operation.	Same as doubler
5	OUT	Power	Positive voltage output	Power supply positive voltage input
6	CAP+	Power	Connect this pin to the positive terminal of the charge-pump capacitor.	Same as doubler

6 Specifications

6.1 Absolute Maximum Ratings

 over operating free-air temperature range (unless otherwise noted)⁽¹⁾⁽²⁾

	MIN	MAX	UNIT
V+ to GND voltage		5.8	V
OUT to GND voltage		11.6	V
OUT to V+ voltage		5.8	V
SD	(GND – 0.3 V)	(V+ + 0.3 V)	
V+ and OUT continuous output current		50	mA
Output short-circuit duration to GND ⁽³⁾		1	sec
Continuous power dissipation (T _A = 25°C) ⁽⁴⁾		600	mW
T _{J-MAX} ⁽⁴⁾		150	°C
Lead temperature (soldering, 10 sec.)		300	°C
Storage temperature, T _{stg}	–65	150	°C

- (1) Stresses beyond those listed under *Absolute Maximum Ratings* may cause permanent damage to the device. These are stress ratings only, which do not imply functional operation of the device at these or any other conditions beyond those indicated under *Recommended Operating Conditions*. Exposure to absolute-maximum-rated conditions for extended periods may affect device reliability.
- (2) If Military/Aerospace specified devices are required, please contact the Texas Instruments Sales Office/ Distributors for availability and specifications.
- (3) OUT may be shorted to GND for one second without damage. However, shorting OUT to V+ may damage the device and must be avoided. Also, for temperatures above 85°C, OUT must not be shorted to GND or V+, or device may be damaged.
- (4) The maximum allowable power dissipation is calculated by using $P_{D-MAX} = (T_{J-MAX} - T_A) / R_{\theta JA}$, where T_{J-MAX} is the maximum junction temperature, T_A is the ambient temperature, and R_{θJA} is the junction-to-ambient thermal resistance of the specified package.

6.2 ESD Ratings

	VALUE	UNIT
V _(ESD) Electrostatic discharge Human-body model (HBM), per ANSI/ESDA/JEDEC JS-001 ⁽¹⁾	±2000	V

- (1) JEDEC document JEP155 states that 500-V HBM allows safe manufacturing with a standard ESD control process.

6.3 Recommended Operating Conditions

over operating free-air temperature range (unless otherwise noted)

	MIN	NOM	MAX	UNIT
Operating junction temperature	–40		85	°C

6.4 Thermal Information

THERMAL METRIC ⁽¹⁾	LM2665	UNIT
	DBV (SOT-23)	
	6 PINS	
R _{θJA} Junction-to-ambient thermal resistance	210	°C/W

- (1) For more information about traditional and new thermal metrics, see the *Semiconductor and IC Package Thermal Metrics* application report, [SPRA953](#).

6.5 Electrical Characteristics

MIN and MAX limits apply over the full operating temperature range. Unless otherwise specified: $T_J = 25^\circ\text{C}$, $V_+ = 5\text{ V}$, $C_1 = C_2 = 3.3\ \mu\text{F}$.⁽¹⁾

PARAMETER	TEST CONDITIONS	MIN ⁽²⁾	TYP ⁽³⁾	MAX ⁽²⁾	UNIT	
V_+	Supply voltage	2.5		5.5	V	
I_Q	Supply current	No load		650	1250	μA
I_{SD}	Shutdown supply current			1		μA
V_{SD}	Shutdown pin input voltage	Normal operation		2 ⁽⁴⁾	V	
		Shutdown mode		0.8 ⁽⁵⁾		
I_L	Output current			40	mA	
R_{SW}	Sum of the $R_{ds(on)}$ of the four internal MOSFET switches	$I_L = 40\text{ mA}$		3.5	8	Ω
R_{OUT}	Output resistance ⁽⁶⁾	$I_L = 40\text{ mA}$		12	25	Ω
f_{OSC}	Oscillator frequency	See ⁽⁷⁾		80	160	kHz
f_{SW}	Switching frequency	See ⁽⁷⁾		40	80	kHz
P_{EFF}	Power efficiency	R_L (1 k Ω) between GND and OUT		90%	94%	
		$I_L = 40\text{ mA}$ to GND		90%		
V_{OEFF}	Voltage conversion efficiency	No load		99%	99.96%	

- (1) In the test circuit, capacitors C_1 and C_2 are 3.3- μF , 0.3- Ω maximum ESR capacitors. Capacitors with higher ESR increase output resistance, reduce output voltage and efficiency.
- (2) Min. and Max. limits are ensured by design, test, or statistical analysis.
- (3) Typical numbers are not ensured but represent the most likely norm.
- (4) The minimum input high for the SD pin equals 40% of V_+ .
- (5) The maximum input low for the SD pin equals 20% of V_+ .
- (6) Specified output resistance includes internal switch resistance and capacitor ESR. See the details in [Application and Implementation](#) for simple negative voltage converter.
- (7) The output switches operate at one half of the oscillator frequency, $f_{OSC} = 2f_{SW}$.

6.6 Typical Characteristics

(Circuit of [Figure 9](#), $V_+ = 5\text{ V}$ unless otherwise specified)

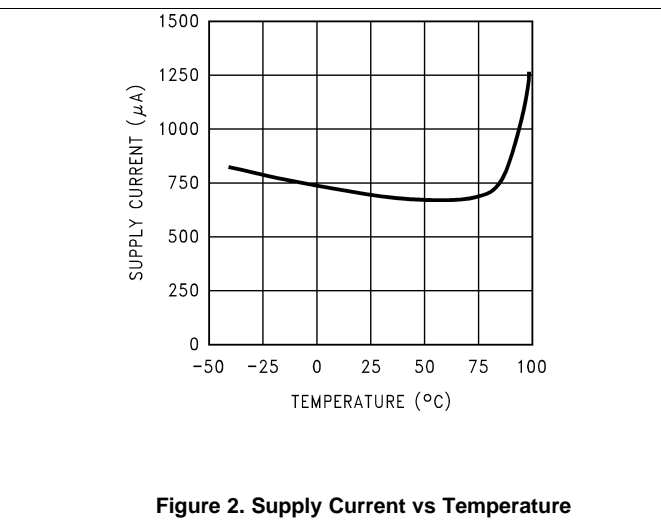
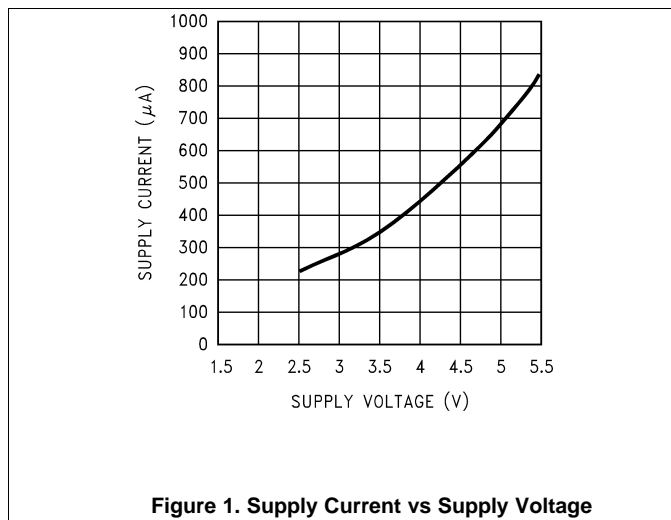

Typical Characteristics (continued)

(Circuit of Figure 9, $V_+ = 5\text{ V}$ unless otherwise specified)

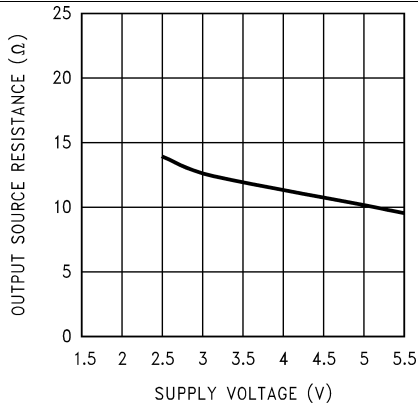

Figure 3. Output Source Resistance vs Supply Voltage

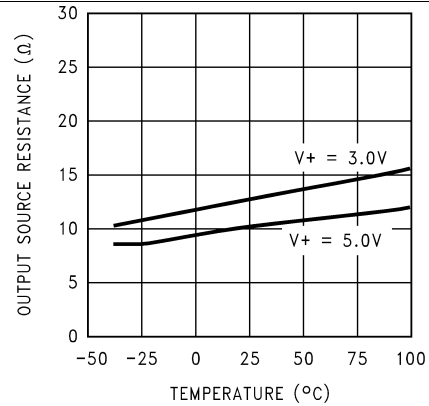

Figure 4. Output Source Resistance vs Temperature

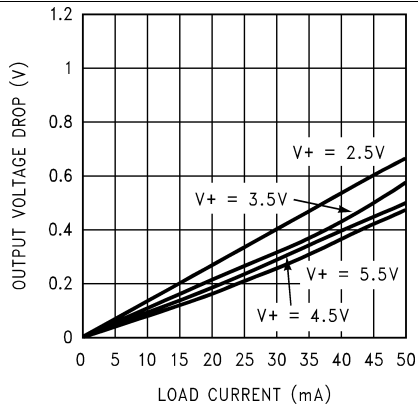

Figure 5. Output Voltage Drop vs Load Current

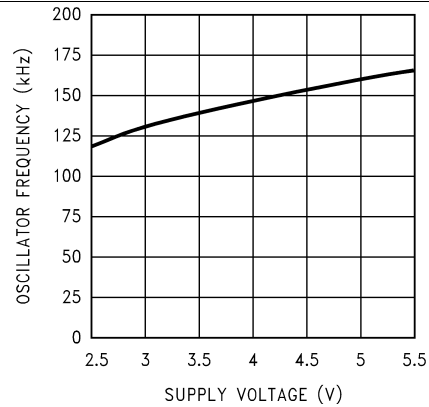

Figure 6. Oscillator Frequency vs Supply Voltage

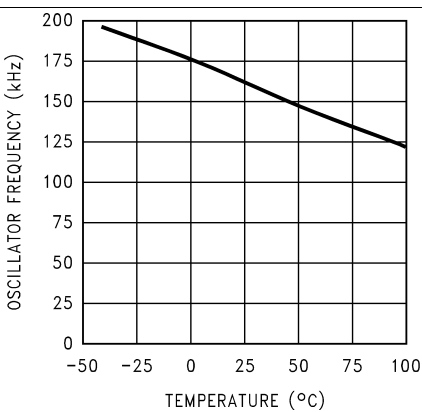

Figure 7. Oscillator Frequency vs Temperature

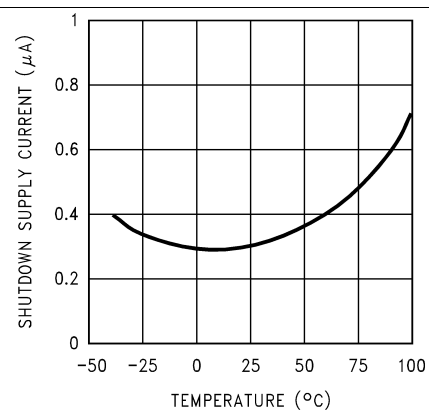
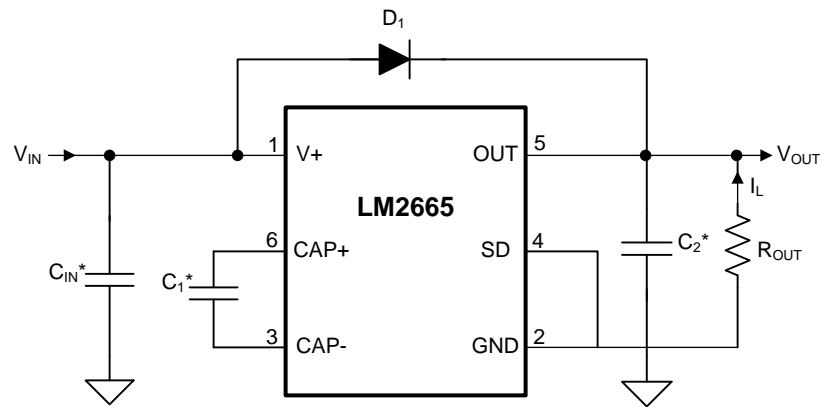

Figure 8. Shutdown Supply Current vs Temperature

7 Parameter Measurement Information

7.1 Test Circuit



* C_{IN} , C_1 and C_2 are 3.3 μ F OS-CON capacitors.

Figure 9. LM2665 Test Circuit

8 Detailed Description

8.1 Overview

The LM2665 CMOS charge-pump voltage converter operates as a voltage doubler for an input voltage in the range of 2.5 V to 5.5 V. Two low-cost capacitors and a diode (needed during start-up) are used in this circuit to provide up to 40 mA of output current. The LM2665 can also work as a voltage divider to split a voltage in the range of 1.8 V to 11 V in half.

8.2 Functional Block Diagram

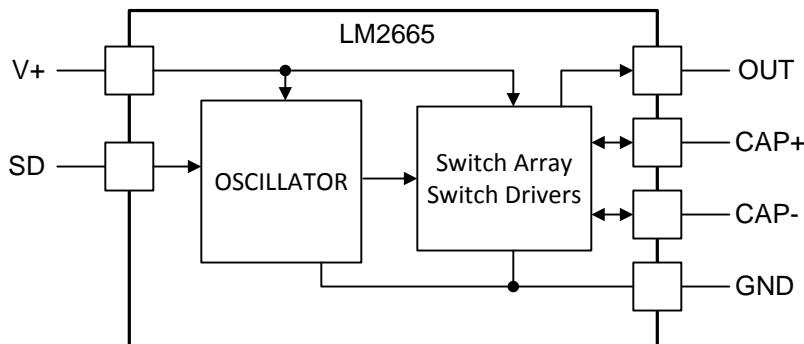

8.3 Feature Description

8.3.1 Circuit Description

The LM2665 contains four large CMOS switches which are switched in a sequence to double the input supply voltage. Energy transfer and storage are provided by external capacitors. [Figure 10](#) illustrates the voltage conversion scheme. When S_2 and S_4 are closed, C_1 charges to the supply voltage V_+ . During this time interval, switches S_1 and S_3 are open. In the next time interval, S_2 and S_4 are open; at the same time, S_1 and S_3 are closed, the sum of the input voltage V_+ and the voltage across C_1 gives the $2 \cdot V_+$ output voltage when there is no load. The output voltage drop when a load is added is determined by the parasitic resistance ($R_{DS(on)}$) of the MOSFET switches and the ESR of the capacitors) and the charge transfer loss between capacitors. Details are discussed in [Application and Implementation](#).

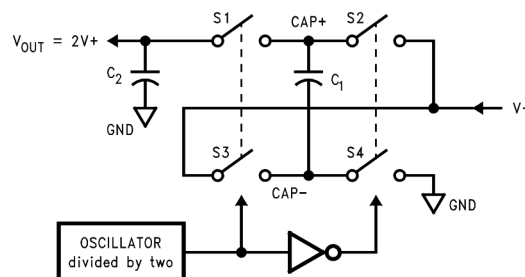

Figure 10. Voltage Doubling Principle

8.4 Device Functional Modes

8.4.1 Shutdown Mode

A shutdown (SD) pin is available to disable the device and reduce the quiescent current to 1 μ A. In normal operating mode, the SD pin is connected to ground. The device can be brought into the shutdown mode by applying to the SD pin a voltage greater than 40% of the V_+ pin voltage.

9 Application and Implementation

NOTE

Information in the following applications sections is not part of the TI component specification, and TI does not warrant its accuracy or completeness. TI's customers are responsible for determining suitability of components for their purposes. Customers must validate and test their design implementation to confirm system functionality.

9.1 Application Information

The LM2665 provides a simple and efficient means of creating an output voltage level equal to twice that of the input voltage. Without the need of an inductor, the application solution size can be reduced versus the magnetic DC-DC converter solution.

9.2 Typical Applications

9.2.1 Voltage Doubler

The main application of the LM2665 is to double the input voltage. The range of the input supply voltage is 2.5 V to 5.5 V.

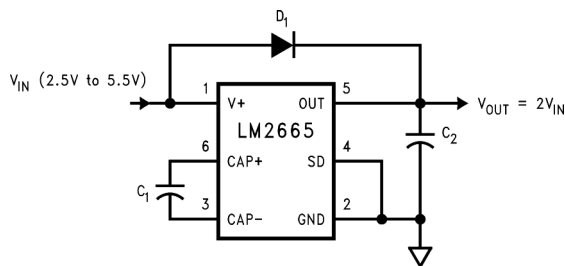

Figure 11. Voltage Doubler

9.2.1.1 Design Requirements

Example requirements for LM2665 device applications:

DESIGN PARAMETER	EXAMPLE VALUE
Input voltage range	2.5 V to 5.5 V
Output current	0 mA to 40 mA
Boost switching frequency	80 kHz

9.2.1.2 Detailed Design Requirements

9.2.1.2.1 Positive Voltage Doubler

The output characteristics of this circuit can be approximated by an ideal voltage source in series with a resistance. The voltage source equals $2V+$. The output resistance R_{OUT} is a function of the ON resistance of the internal MOSFET switches, the oscillator frequency, the capacitance and equivalent series resistance (ESR) of C_1 and C_2 . Since the switching current charging and discharging C_1 is approximately twice as the output current, the effect of the ESR of the pumping capacitor C_1 will be multiplied by four in the output resistance. The output capacitor C_2 is charging and discharging at a current approximately equal to the output current, therefore, its ESR only counts when in the output resistance. A good approximation of R_{OUT} is:

$$R_{OUT} \cong 2R_{SW} + \frac{2}{f_{OSC} \times C_1} + 4ESR_{C1} + ESR_{C2}$$

where

- R_{SW} is the sum of the ON resistance of the internal MOSFET switches shown in [Figure 10](#). (1)

The peak-to-peak output voltage ripple is determined by the oscillator frequency, the capacitance and ESR of the output capacitor C_2 :

$$V_{RIPPLE} = \frac{I_L}{f_{OSC} \times C_2} + 2 \times I_L \times ESR_{C2}$$
 (2)

High capacitance, low-ESR capacitors can reduce both the output resistance and the voltage ripple.

The Schottky diode D_1 is only needed for start-up. The internal oscillator circuit uses the OUT pin and the GND pin. Voltage across OUT and GND must be larger than 1.8 V to insure the operation of the oscillator. During start-up, D_1 is used to charge up the voltage at the OUT pin to start the oscillator; also, it protects the device from turning-on its own parasitic diode and potentially latching-up. Therefore, the Schottky diode D_1 must have enough current carrying capability to charge the output capacitor at start-up, as well as a low forward voltage to prevent the internal parasitic diode from turning-on. A Schottky diode like 1N5817 can be used for most applications. If the input voltage ramp is less than 10 V/ms, a smaller Schottky diode like MBR0520LT1 can be used to reduce the circuit size.

9.2.1.2.2 Capacitor Selection

As discussed in [Positive Voltage Doubler](#), the output resistance and ripple voltage are dependent on the capacitance and ESR values of the external capacitors. The output voltage drop is the load current times the output resistance, and the power efficiency is:

$$\eta = \frac{P_{OUT}}{P_{IN}} = \frac{I_L^2 R_L}{I_L^2 R_L + I_L^2 R_{OUT} + I_Q(V+)}$$

where

- $I_Q(V+)$ is the quiescent power loss of the IC device; and
- $I_L^2 R_{out}$ is the conversion loss associated with the switch on-resistance, the two external capacitors and their ESRs. (3)

The selection of capacitors is based on the specifications of the dropout voltage (which equals $I_{OUT} R_{OUT}$), the output voltage ripple, and the converter efficiency. Low ESR capacitors are recommended to maximize efficiency, reduce the output voltage drop and voltage ripple.

9.2.1.2.3 Paralleling Devices

Any number of LM2665 devices can be paralleled to reduce the output resistance. Each device must have its own pumping capacitor C_1 , while only one output capacitor C_{OUT} is needed as shown in [Figure 12](#). The composite output resistance is:

$$R_{OUT} = \frac{R_{OUT \text{ of each LM2665}}}{\text{Number of Devices}}$$
 (4)

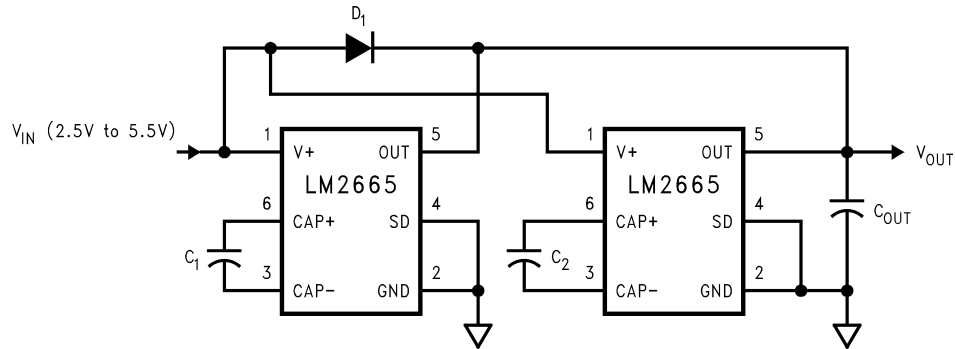

Figure 12. Lowering Output Resistance By Paralleling Devices

9.2.1.2.4 Cascading Devices

Cascading the LM2665 devices is an easy way to produce a greater voltage (a two-stage cascade circuit is shown in Figure 13).

The effective output resistance is equal to the weighted sum of each individual device:

$$R_{OUT} = 1.5 R_{OUT_1} + R_{OUT_2} \quad (5)$$

Note that the increasing of the number of cascading stages is practically limited since it significantly reduces the efficiency, increases the output resistance and output voltage ripple.

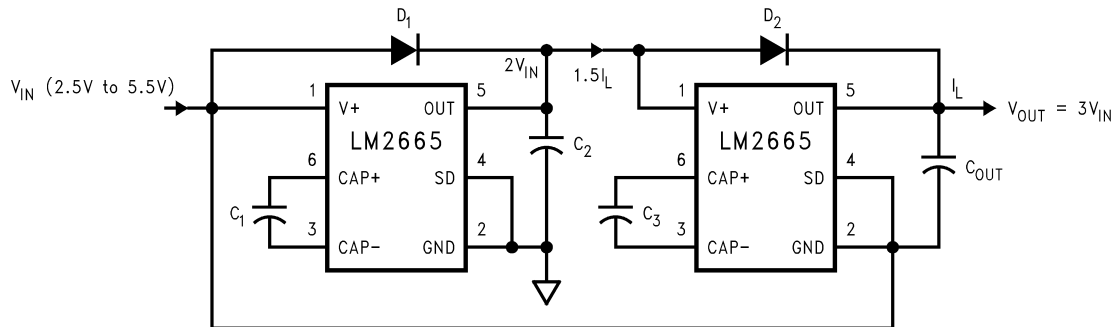

Figure 13. Increasing Output Voltage By Cascading Devices

9.2.1.2.5 Regulating V_{OUT}

It is possible to regulate the output of the LM2665 by use of a low dropout regulator (such as LP2980-5.0). The whole converter is depicted in Figure 14.

A different output voltage is possible by use of LP2980-3.3, LP2980-3.0, or LP2980-ADJ.

Note that the following conditions must be satisfied simultaneously for worst-case design:

$$2V_{IN_MIN} > V_{OUT_MIN} + V_{DROP_MAX} (LP2980) + I_{OUT_MAX} \times R_{OUT_MAX} (LM2665) \quad (6)$$

$$2V_{IN_MAX} < V_{OUT_MAX} + V_{DROP_MIN} (LP2980) + I_{OUT_MIN} \times R_{OUT_MIN} (LM2665) \quad (7)$$

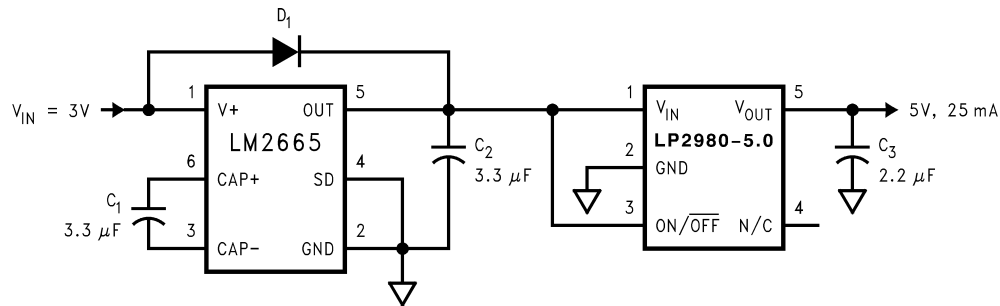

Figure 14. Generate a Regulated 5-V from 3-V Input Voltage

9.2.1.3 Application Curve

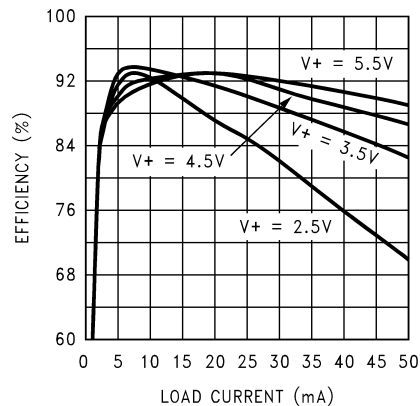

Figure 15. Efficiency vs Load Current

9.2.2 Splitting V+ In Half

Another interesting application shown in *Splitting V_{in} in Half* is using the LM2665 as a precision voltage divider. This circuit can be derived from the voltage doubler by switching the input and output connections. In the voltage divider, the input voltage applies across the OUT pin and the GND pin (which are the power rails for the internal oscillator), therefore no start-up diode is needed. Also, since the off-voltage across each switch equals $V_{IN}/2$, the input voltage can be raised to 11 V.

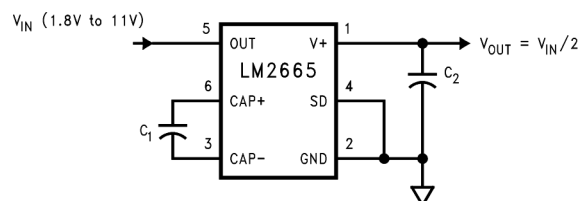

Figure 16. Application Circuit for Splitting Voltage

10 Power Supply Recommendations

The LM2665 is designed to operate from as an inverter over an input voltage supply range between 2.5 V and 5.5 V when the LV pin is grounded. This input supply must be well regulated and capable to supply the required input current. If the input supply is located far from the device, additional bulk capacitance may be required in addition to the ceramic bypass capacitors.

11 Layout

11.1 Layout Guidelines

The high switching frequency and large switching currents of the LM2665 make the choice of layout important. Use the following steps as a reference to ensure the device is stable and maintains proper LED current regulation across its intended operating voltage and current range.

- Place C_{IN} on the top layer (same layer as the LM2665) and as close to the device as possible. Connecting the input capacitor through short, wide traces to both the V+ and GND pins reduces the inductive voltage spikes that occur during switching which can corrupt the V+ line.
- Place C_{OUT} on the top layer (same layer as the LM2665) and as close as possible to the OUT and GND pin. The returns for both C_{IN} and C_{OUT} must come together at one point, as close to the GND pin as possible. Connecting C_{OUT} through short, wide traces reduce the series inductance on the OUT and GND pins that can corrupt the V_{OUT} and GND lines and cause excessive noise in the device and surrounding circuitry.
- Place C1 on the top layer (same layer as the LM2665 device) and as close to the device as possible. Connect the flying capacitor through short, wide traces to both the CAP+ and CAP– pins.

11.2 Layout Example

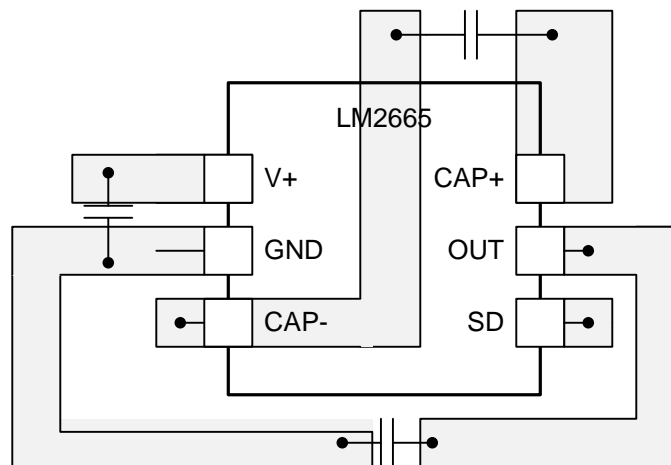

Figure 17. Typical Layout for LM2665

12 Device and Documentation Support

12.1 Community Resources

The following links connect to TI community resources. Linked contents are provided "AS IS" by the respective contributors. They do not constitute TI specifications and do not necessarily reflect TI's views; see TI's [Terms of Use](#).

TI E2E™ Online Community *TI's Engineer-to-Engineer (E2E) Community*. Created to foster collaboration among engineers. At e2e.ti.com, you can ask questions, share knowledge, explore ideas and help solve problems with fellow engineers.

Design Support *TI's Design Support* Quickly find helpful E2E forums along with design support tools and contact information for technical support.

12.2 Trademarks

E2E is a trademark of Texas Instruments.
All other trademarks are the property of their respective owners.

12.3 Electrostatic Discharge Caution



These devices have limited built-in ESD protection. The leads should be shorted together or the device placed in conductive foam during storage or handling to prevent electrostatic damage to the MOS gates.

12.4 Glossary



[SLYZ022](#) — *TI Glossary*.

This glossary lists and explains terms, acronyms, and definitions.

13 Mechanical, Packaging, and Orderable Information

The following pages include mechanical, packaging, and orderable information. This information is the most current data available for the designated devices. This data is subject to change without notice and revision of this document. For browser-based versions of this data sheet, refer to the left-hand navigation.

PACKAGING INFORMATION

Orderable Device	Status (1)	Package Type	Package Drawing	Pins	Package Qty	Eco Plan (2)	Lead/Ball Finish (6)	MSL Peak Temp (3)	Op Temp (°C)	Device Marking (4/5)	Samples
LM2665M6	NRND	SOT-23	DBV	6	1000	TBD	Call TI	Call TI	-40 to 85	S04A	
LM2665M6/NOPB	ACTIVE	SOT-23	DBV	6	1000	Green (RoHS & no Sb/Br)	CU SN	Level-1-260C-UNLIM	-40 to 85	S04A	
LM2665M6X	NRND	SOT-23	DBV	6	3000	TBD	Call TI	Call TI	-40 to 85	S04A	
LM2665M6X/NOPB	ACTIVE	SOT-23	DBV	6	3000	Green (RoHS & no Sb/Br)	CU SN	Level-1-260C-UNLIM	-40 to 85	S04A	

(1) The marketing status values are defined as follows:

ACTIVE: Product device recommended for new designs.

LIFEBUY: TI has announced that the device will be discontinued, and a lifetime-buy period is in effect.

NRND: Not recommended for new designs. Device is in production to support existing customers, but TI does not recommend using this part in a new design.

PREVIEW: Device has been announced but is not in production. Samples may or may not be available.

OBSELETE: TI has discontinued the production of the device.

(2) Eco Plan - The planned eco-friendly classification: Pb-Free (RoHS), Pb-Free (RoHS Exempt), or Green (RoHS & no Sb/Br) - please check <http://www.ti.com/productcontent> for the latest availability information and additional product content details.

TBD: The Pb-Free/Green conversion plan has not been defined.

Pb-Free (RoHS): TI's terms "Lead-Free" or "Pb-Free" mean semiconductor products that are compatible with the current RoHS requirements for all 6 substances, including the requirement that lead not exceed 0.1% by weight in homogeneous materials. Where designed to be soldered at high temperatures, TI Pb-Free products are suitable for use in specified lead-free processes.

Pb-Free (RoHS Exempt): This component has a RoHS exemption for either 1) lead-based flip-chip solder bumps used between the die and package, or 2) lead-based die adhesive used between the die and leadframe. The component is otherwise considered Pb-Free (RoHS compatible) as defined above.

Green (RoHS & no Sb/Br): TI defines "Green" to mean Pb-Free (RoHS compatible), and free of Bromine (Br) and Antimony (Sb) based flame retardants (Br or Sb do not exceed 0.1% by weight in homogeneous material)

(3) MSL, Peak Temp. - The Moisture Sensitivity Level rating according to the JEDEC industry standard classifications, and peak solder temperature.

(4) There may be additional marking, which relates to the logo, the lot trace code information, or the environmental category on the device.

(5) Multiple Device Markings will be inside parentheses. Only one Device Marking contained in parentheses and separated by a "~" will appear on a device. If a line is indented then it is a continuation of the previous line and the two combined represent the entire Device Marking for that device.

(6) Lead/Ball Finish - Orderable Devices may have multiple material finish options. Finish options are separated by a vertical ruled line. Lead/Ball Finish values may wrap to two lines if the finish value exceeds the maximum column width.

Important Information and Disclaimer: The information provided on this page represents TI's knowledge and belief as of the date that it is provided. TI bases its knowledge and belief on information provided by third parties, and makes no representation or warranty as to the accuracy of such information. Efforts are underway to better integrate information from third parties. TI has taken and

continues to take reasonable steps to provide representative and accurate information but may not have conducted destructive testing or chemical analysis on incoming materials and chemicals. TI and TI suppliers consider certain information to be proprietary, and thus CAS numbers and other limited information may not be available for release.

In no event shall TI's liability arising out of such information exceed the total purchase price of the TI part(s) at issue in this document sold by TI to Customer on an annual basis.

TAPE AND REEL INFORMATION

QUADRANT ASSIGNMENTS FOR PIN 1 ORIENTATION IN TAPE

*All dimensions are nominal

Device	Package Type	Package Drawing	Pins	SPQ	Reel Diameter (mm)	Reel Width W1 (mm)	A0 (mm)	B0 (mm)	K0 (mm)	P1 (mm)	W (mm)	Pin1 Quadrant
LM2665M6	SOT-23	DBV	6	1000	178.0	8.4	3.2	3.2	1.4	4.0	8.0	Q3
LM2665M6/NOPB	SOT-23	DBV	6	1000	178.0	8.4	3.2	3.2	1.4	4.0	8.0	Q3
LM2665M6X	SOT-23	DBV	6	3000	178.0	8.4	3.2	3.2	1.4	4.0	8.0	Q3
LM2665M6X/NOPB	SOT-23	DBV	6	3000	178.0	8.4	3.2	3.2	1.4	4.0	8.0	Q3

TAPE AND REEL BOX DIMENSIONS



*All dimensions are nominal

Device	Package Type	Package Drawing	Pins	SPQ	Length (mm)	Width (mm)	Height (mm)
LM2665M6	SOT-23	DBV	6	1000	210.0	185.0	35.0
LM2665M6/NOPB	SOT-23	DBV	6	1000	210.0	185.0	35.0
LM2665M6X	SOT-23	DBV	6	3000	210.0	185.0	35.0
LM2665M6X/NOPB	SOT-23	DBV	6	3000	210.0	185.0	35.0

MECHANICAL DATA

DBV (R-PDSO-G6)

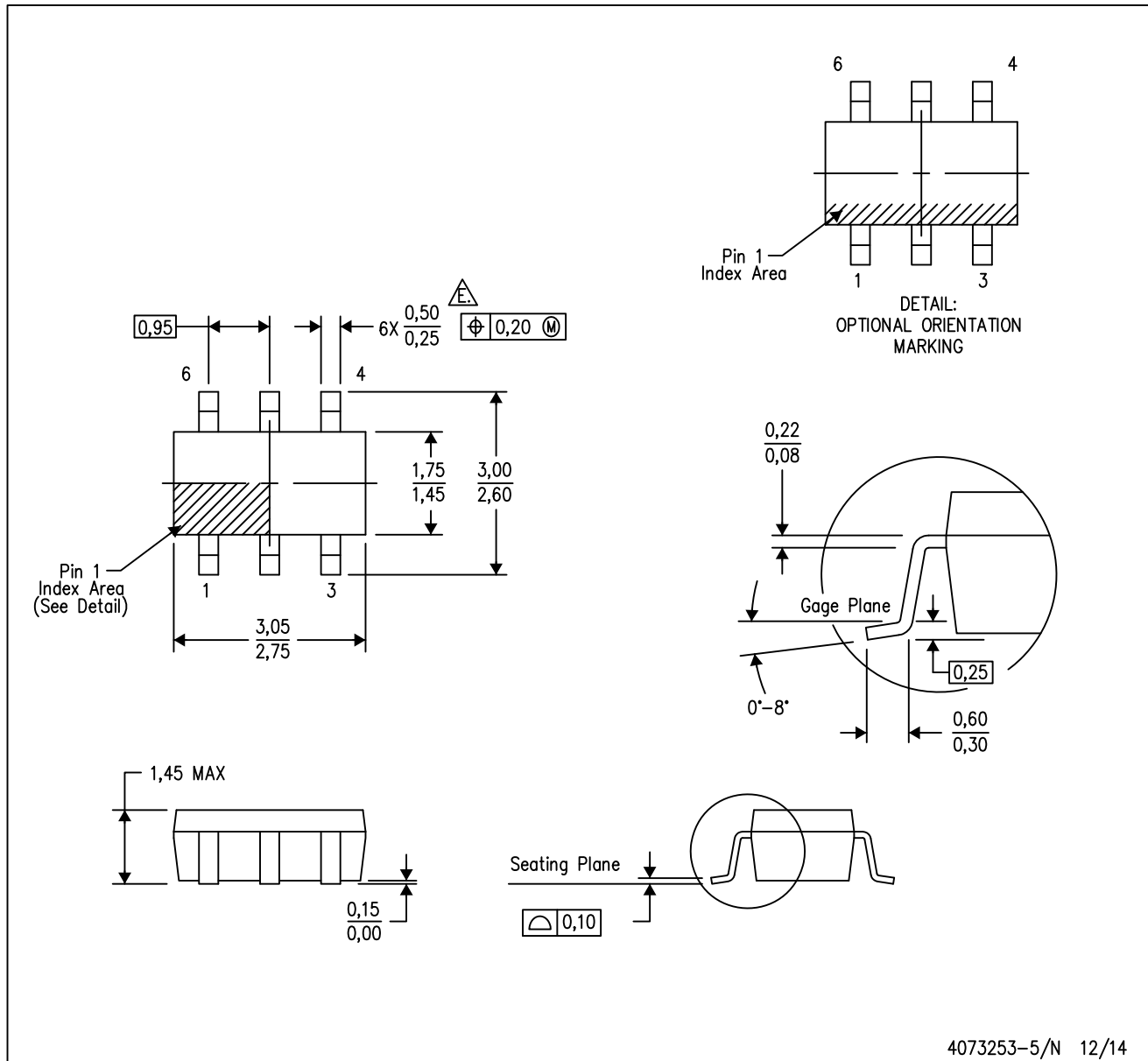
PLASTIC SMALL-OUTLINE PACKAGE



- NOTES:
- All linear dimensions are in millimeters.
 - This drawing is subject to change without notice.
 - Body dimensions do not include mold flash or protrusion. Mold flash and protrusion shall not exceed 0.15 per side.
 - Leads 1,2,3 may be wider than leads 4,5,6 for package orientation.
- ⚠ Falls within JEDEC MO-178 Variation AB, except minimum lead width.

IMPORTANT NOTICE

Texas Instruments Incorporated and its subsidiaries (TI) reserve the right to make corrections, enhancements, improvements and other changes to its semiconductor products and services per JESD46, latest issue, and to discontinue any product or service per JESD48, latest issue. Buyers should obtain the latest relevant information before placing orders and should verify that such information is current and complete. All semiconductor products (also referred to herein as "components") are sold subject to TI's terms and conditions of sale supplied at the time of order acknowledgment.

TI warrants performance of its components to the specifications applicable at the time of sale, in accordance with the warranty in TI's terms and conditions of sale of semiconductor products. Testing and other quality control techniques are used to the extent TI deems necessary to support this warranty. Except where mandated by applicable law, testing of all parameters of each component is not necessarily performed.

TI assumes no liability for applications assistance or the design of Buyers' products. Buyers are responsible for their products and applications using TI components. To minimize the risks associated with Buyers' products and applications, Buyers should provide adequate design and operating safeguards.

TI does not warrant or represent that any license, either express or implied, is granted under any patent right, copyright, mask work right, or other intellectual property right relating to any combination, machine, or process in which TI components or services are used. Information published by TI regarding third-party products or services does not constitute a license to use such products or services or a warranty or endorsement thereof. Use of such information may require a license from a third party under the patents or other intellectual property of the third party, or a license from TI under the patents or other intellectual property of TI.

Reproduction of significant portions of TI information in TI data books or data sheets is permissible only if reproduction is without alteration and is accompanied by all associated warranties, conditions, limitations, and notices. TI is not responsible or liable for such altered documentation. Information of third parties may be subject to additional restrictions.

Resale of TI components or services with statements different from or beyond the parameters stated by TI for that component or service voids all express and any implied warranties for the associated TI component or service and is an unfair and deceptive business practice. TI is not responsible or liable for any such statements.

Buyer acknowledges and agrees that it is solely responsible for compliance with all legal, regulatory and safety-related requirements concerning its products, and any use of TI components in its applications, notwithstanding any applications-related information or support that may be provided by TI. Buyer represents and agrees that it has all the necessary expertise to create and implement safeguards which anticipate dangerous consequences of failures, monitor failures and their consequences, lessen the likelihood of failures that might cause harm and take appropriate remedial actions. Buyer will fully indemnify TI and its representatives against any damages arising out of the use of any TI components in safety-critical applications.

In some cases, TI components may be promoted specifically to facilitate safety-related applications. With such components, TI's goal is to help enable customers to design and create their own end-product solutions that meet applicable functional safety standards and requirements. Nonetheless, such components are subject to these terms.

No TI components are authorized for use in FDA Class III (or similar life-critical medical equipment) unless authorized officers of the parties have executed a special agreement specifically governing such use.

Only those TI components which TI has specifically designated as military grade or "enhanced plastic" are designed and intended for use in military/aerospace applications or environments. Buyer acknowledges and agrees that any military or aerospace use of TI components which have **not** been so designated is solely at the Buyer's risk, and that Buyer is solely responsible for compliance with all legal and regulatory requirements in connection with such use.

TI has specifically designated certain components as meeting ISO/TS16949 requirements, mainly for automotive use. In any case of use of non-designated products, TI will not be responsible for any failure to meet ISO/TS16949.

Products

Audio	www.ti.com/audio
Amplifiers	amplifier.ti.com
Data Converters	dataconverter.ti.com
DLP® Products	www.dlp.com
DSP	dsp.ti.com
Clocks and Timers	www.ti.com/clocks
Interface	interface.ti.com
Logic	logic.ti.com
Power Mgmt	power.ti.com
Microcontrollers	microcontroller.ti.com
RFID	www.ti-rfid.com
OMAP Applications Processors	www.ti.com/omap
Wireless Connectivity	www.ti.com/wirelessconnectivity

Applications

Automotive and Transportation	www.ti.com/automotive
Communications and Telecom	www.ti.com/communications
Computers and Peripherals	www.ti.com/computers
Consumer Electronics	www.ti.com/consumer-apps
Energy and Lighting	www.ti.com/energy
Industrial	www.ti.com/industrial
Medical	www.ti.com/medical
Security	www.ti.com/security
Space, Avionics and Defense	www.ti.com/space-avionics-defense
Video and Imaging	www.ti.com/video

TI E2E Community

e2e.ti.com