

Distributed by:

**JAMECO**<sup>®</sup>  
ELECTRONICS

**www.Jameco.com ♦ 1-800-831-4242**

The content and copyrights of the attached  
material are the property of its owner.

Jameco Part Number 1992849

## LM2621

# Low Input Voltage, Step-Up DC-DC Converter

### General Description

The LM2621 is a high efficiency, step-up DC-DC switching regulator for battery-powered and low input voltage systems. It accepts an input voltage between 1.2V and 14V and converts it into a regulated output voltage. The output voltage can be adjusted between 1.24V and 14V. It has an internal 0.17 $\Omega$  N-Channel MOSFET power switch. Efficiencies up to 90% are achievable using the LM2621.

The high switching frequency (adjustable up to 2MHz) of the LM2621 allows for tiny surface mount inductors and capacitors. Because of the unique constant-duty-cycle gated oscillator topology very high efficiencies are realized over a wide load range. The supply current is reduced to 80 $\mu$ A because of the BiCMOS process technology. In the shutdown mode, the supply current is less than 2.5 $\mu$ A.

The LM2621 is available in a Mini-SO-8 package. This package uses half the board area of a standard 8-pin SO and has a height of just 1.09 mm.

### Features

- Small Mini-SO8 Package (Half the Footprint of Standard 8-Pin SO Package)

- 1.09 mm Package Height
- Up to 2 MHz Switching Frequency
- 1.2V to 14V Input Voltage
- 1.24V - 14V Adjustable Output Voltage
- Up to 1A Load Current
- 0.17  $\Omega$  Internal MOSFET
- Up to 90% Regulator Efficiency
- 80  $\mu$ A Typical Operating Current
- <2.5 $\mu$ A Guaranteed Supply Current In Shutdown

### Applications

- PDAs, Cellular Phones
- 2-Cell and 3-Cell Battery-Operated Equipment
- PCMCIA Cards, Memory Cards
- Flash Memory Programming
- TFT/LCD Applications
- 3.3V to 5.0V Conversion
- GPS Devices
- Two-Way Pagers
- Palmtop Computers
- Hand-Held Instruments

### Typical Application Circuit

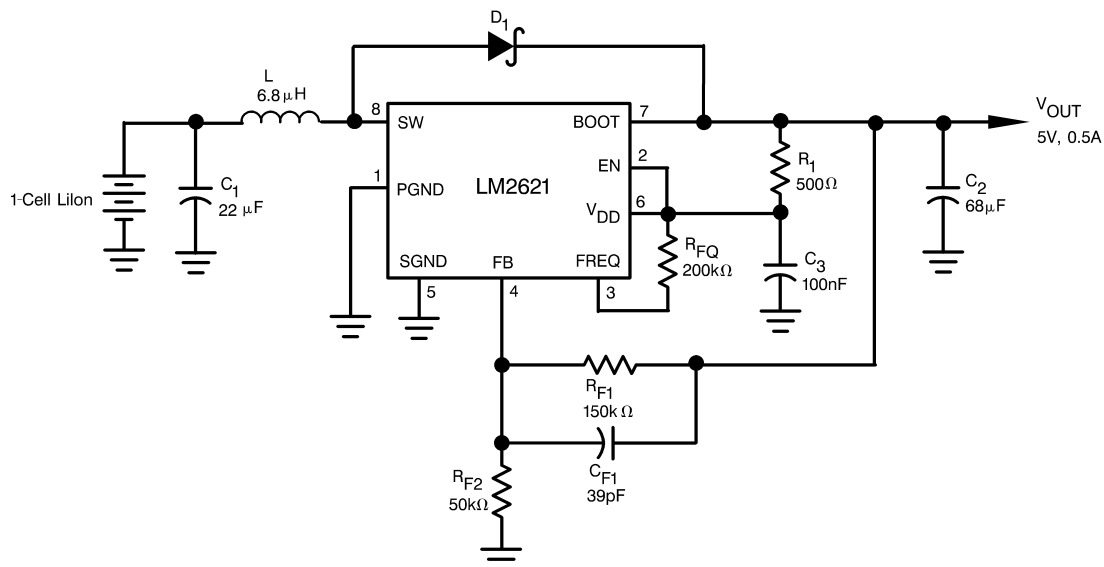

10093412

## Connection Diagram

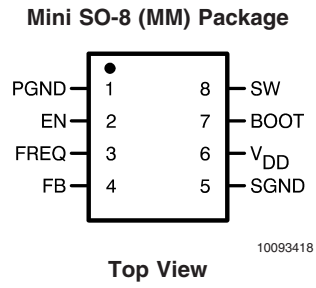

## Ordering Information

Order Number	Package Type	NSC Package Drawing	Package Marking	Supplied As
LM2621MMX	Mini SO-8	MUA08A	S06A	3000 Units on Tape and Reel
LM2621MM	Mini SO-8	MUA08A	S06A	1000 Units on Tape and Reel

**Absolute Maximum Ratings** (Note 1)

If Military/Aerospace specified devices are required, please contact the National Semiconductor Sales Office/Distributors for availability and specifications.

SW Pin Voltage	-0.5 V to 14.5V
BOOT, V <sub>DD</sub> , EN and FB Pins	-0.5V to 10V
FREQ Pin	100μA
θ <sub>JA</sub> (Note 2)	240°C/W
T <sub>Jmax</sub> (Note 2)	150°C
Storage Temperature Range	-65°C to +150°C
Lead Temp. (Soldering, 5 sec)	260°C

Power Dissipation (T <sub>A</sub> =25°C) (Note 2)	500mW
ESD Rating (Note 3)	2kV

**Operating Conditions** (Note 1)

V <sub>DD</sub> Pin	2.5V to 5V
FB, EN Pins	0 to V <sub>DD</sub>
BOOT Pin	0 to 10V
Ambient Temperature (T <sub>A</sub> )	-40°C to +85°C

**Electrical Characteristics**

Limits in standard typeface are for T<sub>J</sub> = 25°C, and limits in **boldface** type apply over the full operating temperature range of -40°C to +85°C. Unless otherwise specified: V<sub>DD</sub> = V<sub>OUT</sub> = 3.3V.

Symbol	Parameter	Condition	Typ	Min	Max	Units
V <sub>IN_ST</sub>	Minimum Start-Up Supply Voltage (Note 4)	I <sub>LOAD</sub> = 0mA	1.1		<b>1.2</b>	V
V <sub>IN_OP</sub>	Minimum Operating Supply Voltage (once started)	I <sub>LOAD</sub> = 0mA	0.65			V
V <sub>FB</sub>	FB Pin Voltage		1.24	<b>1.2028</b>	<b>1.2772</b>	V
V <sub>OUT_MAX</sub>	Maximum Output Voltage		14			V
V <sub>HYST</sub>	Hysteresis Voltage (Note 7)		30		<b>45</b>	mV
η	Efficiency	V <sub>IN</sub> = 3.6V; V <sub>OUT</sub> = 5V; I <sub>LOAD</sub> = 500mA	87			%
		V <sub>IN</sub> = 2.5V; V <sub>OUT</sub> = 3.3V; I <sub>LOAD</sub> = 200mA	87			
D	Switch Duty Cycle		70	<b>60</b>	<b>80</b>	%
I <sub>DD</sub>	Operating Quiescent Current (Note 6)	FB Pin > 1.3V; EN Pin at V <sub>DD</sub>	80		<b>110</b>	μA
I <sub>SD</sub>	Shutdown Quiescent Current (Note 7)	V <sub>DD</sub> , BOOT and SW Pins at 5.0V; EN Pin <200mV	0.01		<b>2.5</b>	μA
I <sub>CL</sub>	Switch Peak Current Limit		2.85			A
R <sub>DS_ON</sub>	MOSFET Switch On Resistance		0.17			Ω

**Enable Section**

V <sub>EN_LO</sub>	EN Pin Voltage Low (Note 8)				<b>0.15V<sub>DD</sub></b>	V
V <sub>EN_HI</sub>	EN Pin Voltage High (Note 8)			<b>0.7V<sub>DD</sub></b>		V

**Note 1:** Absolute maximum ratings indicate limits beyond which damage to the device may occur. Electrical specifications do not apply when operating the device outside of its rated operating conditions.

**Note 2:** The maximum power dissipation must be derated at elevated temperatures and is dictated by T<sub>Jmax</sub> (maximum junction temperature), θ<sub>JA</sub> (junction to ambient thermal resistance), and T<sub>A</sub> (ambient temperature). The maximum allowable power dissipation at any temperature is P<sub>dmax</sub> = (T<sub>Jmax</sub> - T<sub>A</sub>) / θ<sub>JA</sub> or the number given in the Absolute Maximum Ratings, whichever is lower.

**Note 3:** The human body model is a 100 pF capacitor discharged through a 1.5 kΩ resistor into each pin. For Pin 8 (SW) the ESD rating is 1.5 kV.

**Note 4:** Output in regulation, V<sub>OUT</sub> = V<sub>OUT (NOMINAL)</sub> ± 5%

**Note 5:** This is the hysteresis value of the internal comparator used for the gated-oscillator control scheme.

**Note 6:** This is the current into the V<sub>DD</sub> pin.

**Note 7:** This is the total current into pins V<sub>DD</sub>, BOOT, SW and FREQ.

**Note 8:** When the EN pin is below V<sub>EN\_LO</sub>, the regulator is shut down; when it is above V<sub>EN\_HI</sub>, the regulator is operating.

## Pin Description

Pin	Name	Function
1	PGND	Power Ground
2	EN	Active-Low Shutdown Input
3	FREQ	Frequency Adjust. An external resistor connected between this pin and Pin 6 ( $V_{DD}$ ) sets the switching frequency of the LM2621.
4	FB	Output Voltage Feedback
5	SGND	Signal Ground
6	$V_{DD}$	Power Supply for Internal Circuitry
7	BOOT	Bootstrap Supply for the Gate Drive of Internal MOSFET Power Switch
8	SW	Drain of the Internal MOSFET Power Switch

## Typical Performance Characteristics

Efficiency vs Load Current  
 $V_{OUT} = 5.0V$

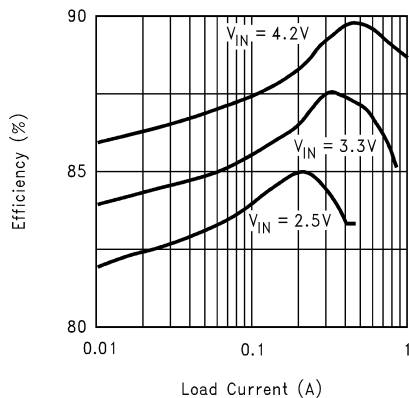

Efficiency vs Load Current  
 $V_{OUT} = 3.3V$

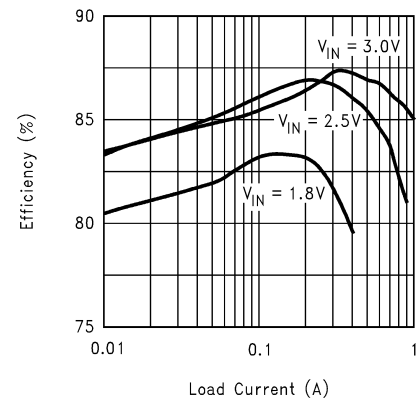

$V_{FB}$  vs Temperature

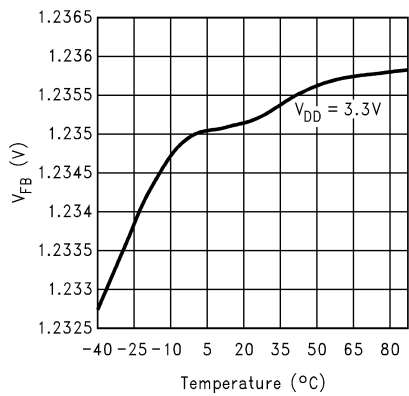

$I_{OP}$  vs Temperature

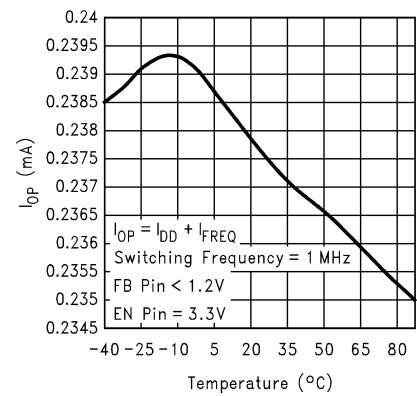

Typical Performance Characteristics (Continued)

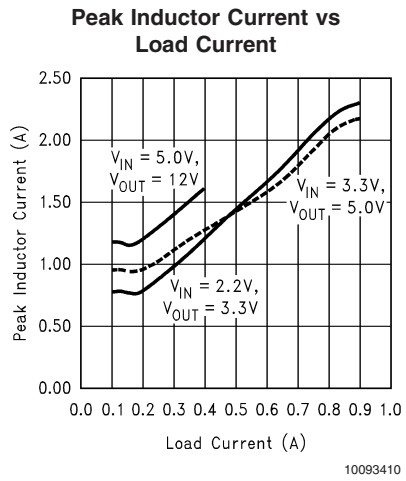
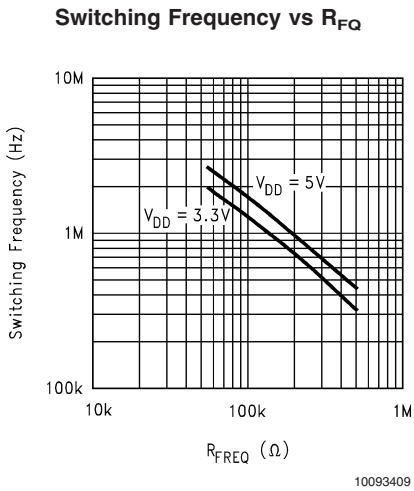
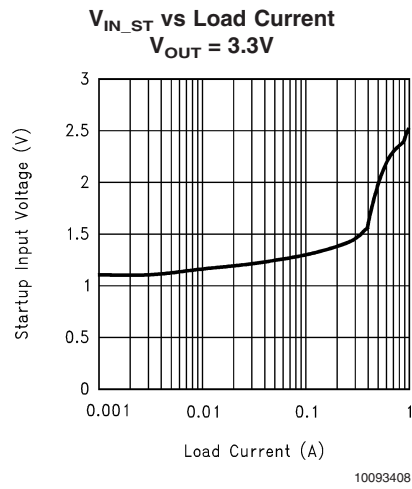
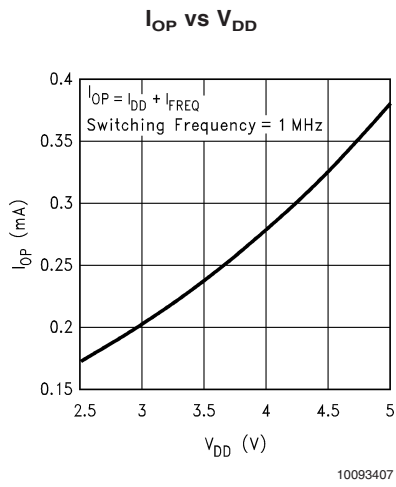
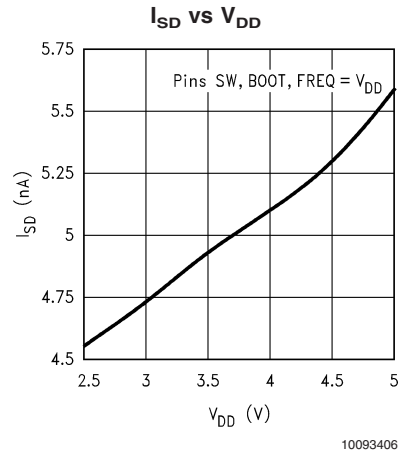
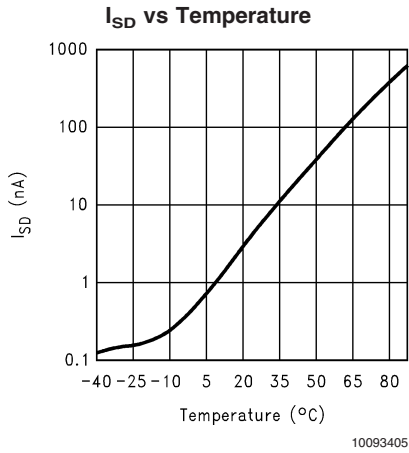

## Typical Performance Characteristics (Continued)

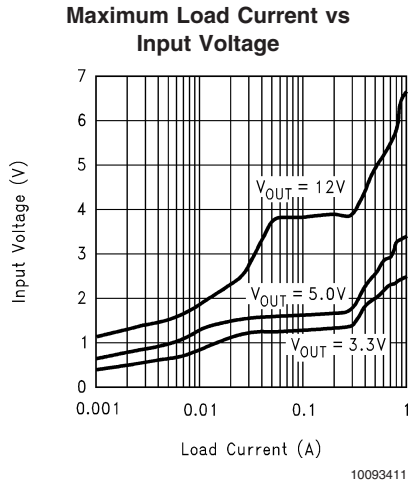

## Detailed Description

### OPERATING PRINCIPLE

The LM2621 is designed to provide step-up DC-DC voltage regulation in battery-powered and low-input voltage systems. It combines a step-up switching regulator, N-channel power MOSFET, built-in current limit, thermal limit, and voltage reference in a single 8-pin MSOP package. The switching DC-DC regulator boosts an input voltage between 1.2V and 14V to a regulated output voltage between 1.24V and

14V. The LM2621 starts from a low 1.1V input and remains operational down to 0.65V.

This device is optimized for use in cellular phones and other applications requiring a small size, low profile, as well as low quiescent current for maximum battery life during stand-by and shutdown. A high-efficiency gated-oscillator topology offers an output of up to 1A.

Additional features include a built-in peak switch current limit, and thermal protection circuitry.

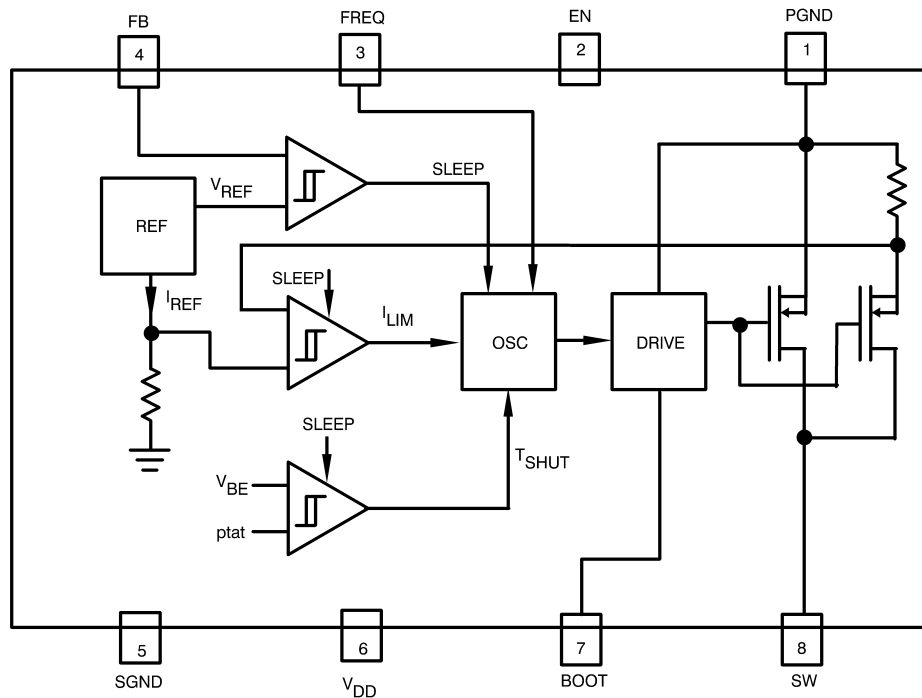

FIGURE 1. Functional Diagram

## Detailed Description (Continued)

### GATED OSCILLATOR CONTROL SCHEME

A unique gated oscillator control scheme enables the LM2621 to have an ultra-low quiescent current and provides a high efficiency over a wide load range. The switching frequency of the internal oscillator is programmable using an external resistor and can be set between 300 kHz and 2 MHz.

This control scheme uses a hysteresis window to regulate the output voltage. When the output voltage is below the upper threshold of the window, the LM2621 switches continuously with a fixed duty cycle of 70% at the switching frequency selected by the user. During the first part of each switching cycle, the internal N-channel MOSFET switch is turned on. This causes the current to ramp up in the inductor and store energy. During the second part of each switching

cycle, the MOSFET is turned off. The voltage across the inductor reverses and forces current through the diode to the output filter capacitor and the load. Thus when the LM2621 switches continuously, the output voltage starts to ramp up. When the output voltage hits the upper threshold of the window, the LM2621 stops switching completely. This causes the output voltage to droop because the energy stored in the output capacitor is depleted by the load. When the output voltage hits the lower threshold of the hysteresis window, the LM2621 starts switching continuously again causing the output voltage to ramp up towards the upper threshold. *Figure 2* shows the switch voltage and output voltage waveforms.

Because of this type of control scheme, the quiescent current is inherently very low. At light loads the gated oscillator control scheme offers a much higher efficiency compared to the conventional PWM control scheme.

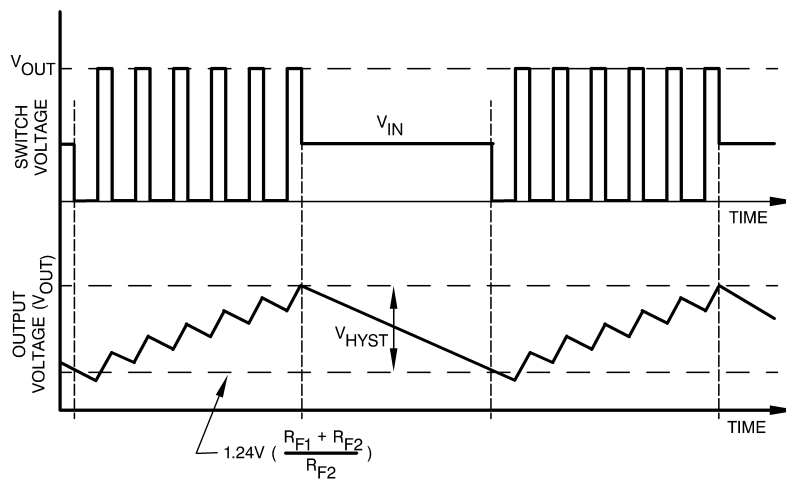

10093415

FIGURE 2. Typical Step-Up Regulator Waveforms

### LOW VOLTAGE START-UP

The LM2621 can start-up from input voltages as low as 1.1V. On start-up, the control circuitry switches the N-channel MOSFET continuously at 70% duty cycle until the output voltage reaches 2.5V. After this output voltage is reached, the normal step-up regulator feedback and gated oscillator control scheme take over. Once the device is in regulation it can operate down to a 0.65V input, since the internal power for the IC can be boot-strapped from the output using the  $V_{DD}$  pin.

### SHUTDOWN

The LM2621 features a shutdown mode that reduces the quiescent current to less than a guaranteed 2.5 $\mu$ A over temperature. This extends the life of the battery in battery powered applications. During shutdown, all feedback and control circuitry is turned off. The regulator's output voltage drops to one diode drop below the input voltage. Entry into the shutdown mode is controlled by the active-low logic input pin EN (Pin 2). When the logic input to this pin pulled below 0.15 $V_{DD}$ , the device goes into shutdown mode. The logic input to this pin should be above 0.7 $V_{DD}$  for the device to work in normal step-up mode.

### OUTPUT VOLTAGE RIPPLE FREQUENCY

A major component of the output voltage ripple is due to the hysteresis used in the gated oscillator control scheme. The frequency of this voltage ripple is proportional to the load current. The frequency of this ripple does not necessitate the use of larger inductors and capacitors however, since the size of these components is determined by the switching frequency of the oscillator which can be set upto 2MHz using an external resistor.

### INTERNAL CURRENT LIMIT AND THERMAL PROTECTION

An internal cycle-by-cycle current limit serves as a protection feature. This is set high enough (2.85A typical, approximately 4A maximum) so as not to come into effect during normal operating conditions. An internal thermal protection circuitry disables the MOSFET power switch when the junction temperature ( $T_J$ ) exceeds about 160°C. The switch is re-enabled when  $T_J$  drops below approximately 135°C.

## Design Procedure

### SETTING THE OUTPUT VOLTAGE

The output voltage of the step-up regulator can be set between 1.24V and 14V by connecting a feedback resistive divider made of  $R_{F1}$  and  $R_{F2}$ . The resistor values are selected as follows:

$$R_{F2} = R_{F1} / [(V_{OUT} / 1.24) - 1]$$

A value of 150k $\Omega$  is suggested for  $R_{F1}$ . Then,  $R_{F2}$  can be selected using the above equation. A 39pF capacitor ( $C_{F1}$ ) connected across  $R_{F1}$  helps in feeding back most of the AC ripple at  $V_{OUT}$  to the FB pin. This helps reduce the peak-to-peak output voltage ripple as well as improve the efficiency of the step-up regulator, because a set hysteresis of 30mV at the FB pin is used for the gated oscillator control scheme.

### BOOTSTRAPPING

When the output voltage ( $V_{OUT}$ ) is between 2.5V and 5.0V a bootstrapped operation is suggested. This is achieved by connecting the  $V_{DD}$  pin (Pin 6) to  $V_{OUT}$ . However if the  $V_{OUT}$  is outside this range, the  $V_{DD}$  pin should be connected to a voltage source whose range is between 2.5V and 5V. This can be the input voltage ( $V_{IN}$ ),  $V_{OUT}$  stepped down using a linear regulator, or a different voltage source available in the system. This is referred to as non-bootstrapped operation. The maximum acceptable voltage at the BOOT pin (Pin 7) is 10V.

### SETTING THE SWITCHING FREQUENCY

The switching frequency of the oscillator is selected by choosing an external resistor ( $R_{FQ}$ ) connected between FREQ and  $V_{DD}$  pins. See the graph titled „Switching Frequency vs  $R_{FQ}$ “ in the Typical Operating Characteristics section of the datasheet for choosing the  $R_{FQ}$  value to achieve the desired switching frequency. A high switching frequency allows the use of very small surface mount inductors and capacitors and results in a very small solution size. A switching frequency between 300kHz and 2MHz is recommended.

### INDUCTOR SELECTION

The LM2621's high switching frequency enables the use of a small surface mount inductor. A 6.8 $\mu$ H shielded inductor is suggested. The inductor should have a saturation current rating higher than the peak current it will experience during circuit operation (see graph titled „Peak Inductor Current vs. Load Current“ in the Typical Performance Characteristics section). Less than 100m $\Omega$  ESR is suggested for high efficiency.

Open-core inductors cause flux linkage with circuit components and interfere with the normal operation of the circuit. They should be avoided. For high efficiency, choose an inductor with a high frequency core material, such as ferrite, to reduce the core losses. To minimize radiated noise, use a toroid, pot core or shielded core inductor. The inductor should be connected to the SW pin as close to the IC as possible. See *Table 1* for a list of the inductor manufacturers.

### OUTPUT DIODE SELECTION

A Schottky diode should be used for the output diode. The forward current rating of the diode should be higher than the load current, and the reverse voltage rating must be higher than the output voltage. Do not use ordinary rectifier diodes, since slow switching speeds and long recovery times cause the efficiency and the load regulation to suffer. *Table 1* shows a list of the diode manufacturers.

### INPUT AND OUTPUT FILTER CAPACITORS SELECTION

Tantalum chip capacitors are recommended for the input and output filter capacitors. A 22 $\mu$ F capacitor is suggested for the input filter capacitor. It should have a DC working voltage rating higher than the maximum input voltage. A 68 $\mu$ F tantalum capacitor is suggested for the output capacitor. The DC working voltage rating should be greater than the output voltage. Very high ESR values (>3 $\Omega$ ) should be avoided. *Table 1* shows a list of the capacitor manufacturers.

TABLE 1. Suggested Manufacturers List

Inductors	Capacitors	Diodes
<b>Coilcraft</b> Tel: (800) 322-2645 Fax: (708) 639-1469	<b>Sprague/ Vishay</b> Tel: (207) 324-4140 Fax: (207) 324-7223	<b>Motorola</b> Tel: (800) 521-6274 Fax: (602) 244-6609
<b>Coiltronics</b> Tel: (407) 241-7876 Fax: (407) 241-9339	<b>Kemet</b> Tel: (864) 963-6300 Fax: (864) 963-6521	<b>International Rectifier (IR)</b> Tel: (310) 322-3331 Fax: (310) 322-3332
<b>Pulse Engineering</b> Tel: (619) 674-8100 Fax: (619) 674-8262	<b>Nichicon</b> Tel: (847) 843-7500 Fax: (847) 843-2798	<b>General Semiconductor</b> Tel: (516) 847-3222 Fax: (516) 847-3150

### PC BOARD LAYOUT

High switching frequencies and high peak currents make a proper layout of the PC board an important part of design. Poor design can cause excessive EMI and ground-bounce, both of which can cause malfunction and loss of regulation by corrupting voltage feedback signal and injecting noise into the control section.

Power components - such as the inductor, input and output filter capacitors, and output diode - should be placed as close to the regulator IC as possible, and their traces should be kept short, direct and wide. The ground pins of the input

and output filter capacitors and the PGND and SGND pins of LM2621 should be connected using short, direct and wide traces. The voltage feedback network ( $R_{F1}$ ,  $R_{F2}$ , and  $C_{F1}$ ) should be kept very close to the FB pin. Noisy traces, such as from the SW pin, should be kept away from the FB and  $V_{DD}$  pins. The traces that run between  $V_{out}$  and the FB pin of the IC should be kept away from the inductor flux. Always provide sufficient copper area to dissipate the heat due to power loss in the circuitry and prevent the thermal protection circuitry in the IC from shutting the IC down.

# Application examples

**EXAMPLE 1. 5V/0.5A Step-Up Regulator**

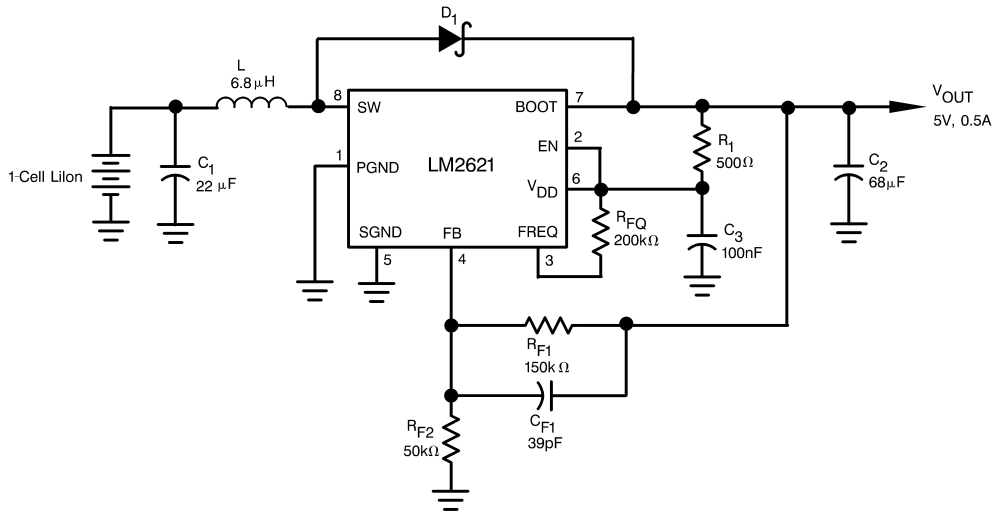

10093412

U1	National	LM2621MM
C1	Vishay/Sprague	595D226X06R3B2T, Tantalum
C2	Vishay/Sprague	595D686X0010C2T, Tantalum
D1	Motorola	MBRS140T3
L	Coilcraft	DT1608C-682

**EXAMPLE 2. 2mm Tall 5V/0.2A Step-Up Regulator for Low Profile Applications**

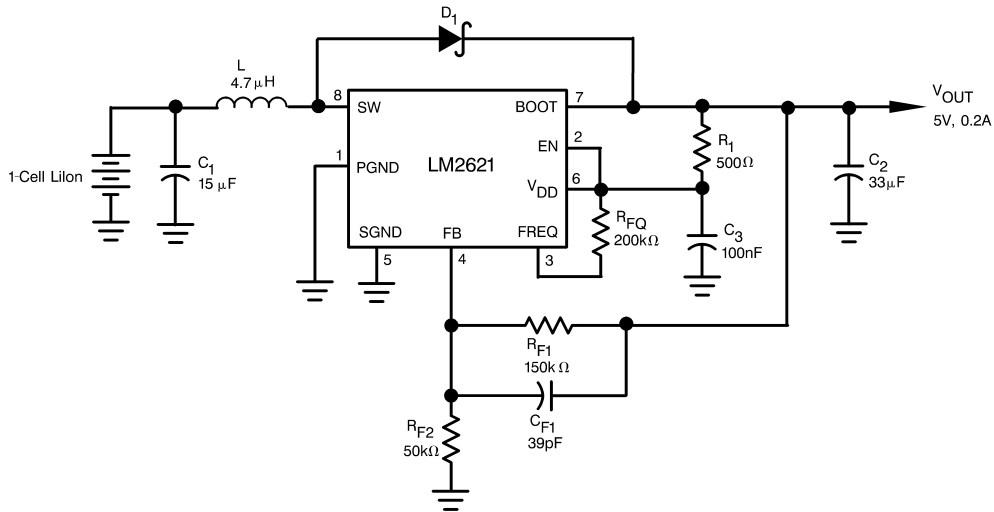

10093417

U1	National	LM2621MM
C1	Vishay/Sprague	592D156X06R3B2T, Tantalum
C2	Vishay/Sprague	592D336X06R3C2T, Tantalum
D1	Motorola	MBRS140T3
L	Vishay/Dale	ILS-3825-03

EXAMPLE 3. 3.3V/0.5A SEPIC Regulator

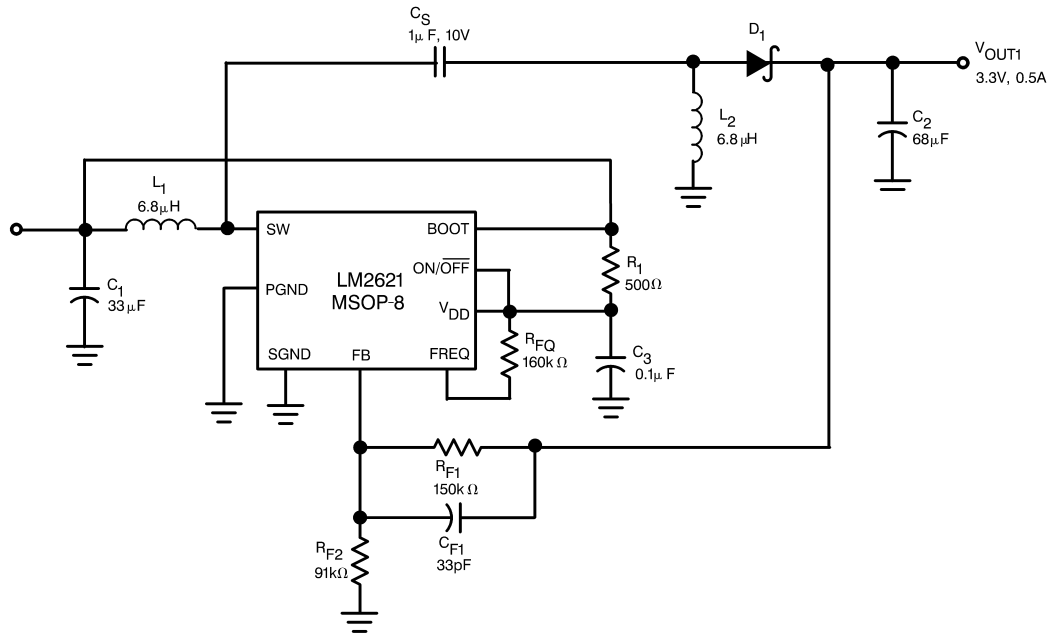

10093422

U1	National	LM2621MM
C1	Vishay/Sprague	595D226X06R3B2T, Tantalum
C2	Vishay/Sprague	595D686X0010C2T, Tantalum
D1	Motorola	MBRS140T3
L1, L2	Coilcraft	DT1608C-682
CS	Vishay/Vitramon	VJ1210Y105M, Ceramic

## Physical Dimensions inches (millimeters)

unless otherwise noted

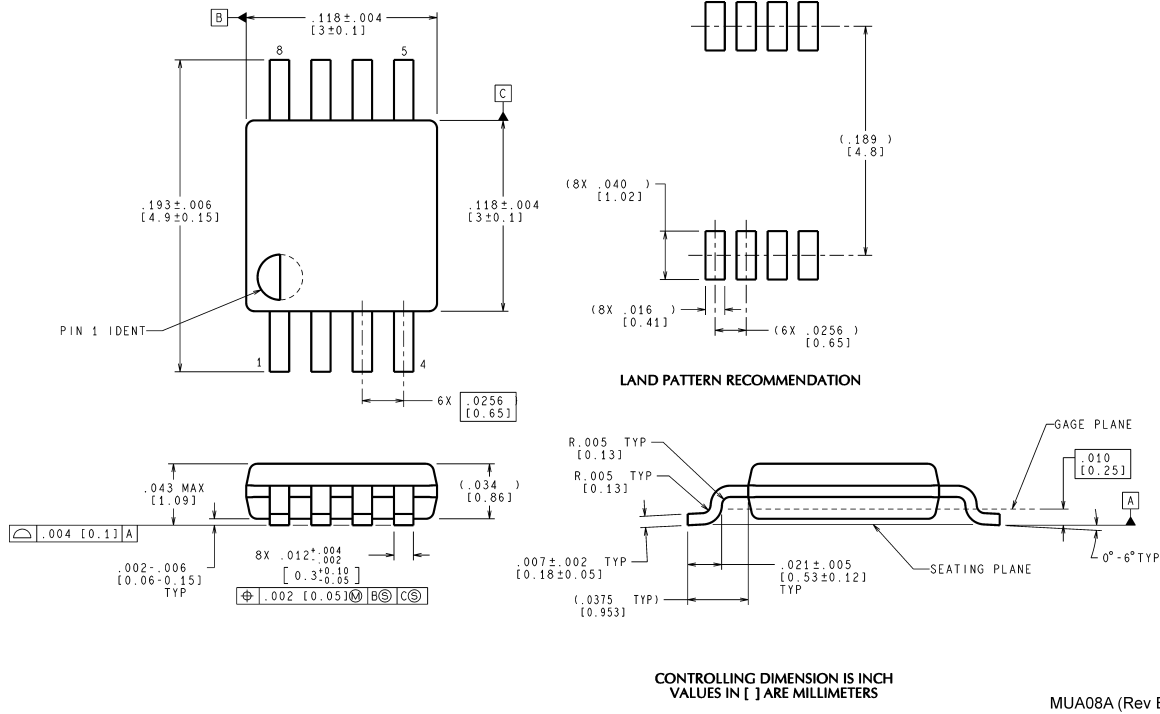

### 8-Lead Mini SO-8 (MM) NS Package Number MUA08A

For Order Numbers, refer to the table in the "Ordering Information" section of this document.

National does not assume any responsibility for use of any circuitry described, no circuit patent licenses are implied and National reserves the right at any time without notice to change said circuitry and specifications.

For the most current product information visit us at [www.national.com](http://www.national.com).

#### LIFE SUPPORT POLICY

NATIONAL'S PRODUCTS ARE NOT AUTHORIZED FOR USE AS CRITICAL COMPONENTS IN LIFE SUPPORT DEVICES OR SYSTEMS WITHOUT THE EXPRESS WRITTEN APPROVAL OF THE PRESIDENT AND GENERAL COUNSEL OF NATIONAL SEMICONDUCTOR CORPORATION. As used herein:

1. Life support devices or systems are devices or systems which, (a) are intended for surgical implant into the body, or (b) support or sustain life, and whose failure to perform when properly used in accordance with instructions for use provided in the labeling, can be reasonably expected to result in a significant injury to the user.
2. A critical component is any component of a life support device or system whose failure to perform can be reasonably expected to cause the failure of the life support device or system, or to affect its safety or effectiveness.

#### BANNED SUBSTANCE COMPLIANCE

National Semiconductor manufactures products and uses packing materials that meet the provisions of the Customer Products Stewardship Specification (CSP-9-111C2) and the Banned Substances and Materials of Interest Specification (CSP-9-111S2) and contain no "Banned Substances" as defined in CSP-9-111S2.



**National Semiconductor**  
Americas Customer  
Support Center  
Email: [new.feedback@nsc.com](mailto:new.feedback@nsc.com)  
Tel: 1-800-272-9959

**National Semiconductor**  
Europe Customer Support Center  
Fax: +49 (0) 180-530 85 86  
Email: [europe.support@nsc.com](mailto:europe.support@nsc.com)  
Deutsch Tel: +49 (0) 69 9508 6208  
English Tel: +44 (0) 870 24 0 2171  
Français Tel: +33 (0) 1 41 91 8790

**National Semiconductor**  
Asia Pacific Customer  
Support Center  
Email: [ap.support@nsc.com](mailto:ap.support@nsc.com)

**National Semiconductor**  
Japan Customer Support Center  
Fax: 81-3-5639-7507  
Email: [jpn.feedback@nsc.com](mailto:jpn.feedback@nsc.com)  
Tel: 81-3-5639-7560