

LM158, LM158A, LM258, LM258A LM358, LM358A, LM2904, LM2904V DUAL OPERATIONAL AMPLIFIERS

SLOS068P – JUNE 1976 – REVISED SEPTEMBER 2004

- **Wide Supply Range:**
 - Single Supply . . . 3 V to 32 V
(26 V for LM2904)
 - or Dual Supplies . . . ± 1.5 V to ± 16 V
(± 13 V for LM2904)
- **Low Supply-Current Drain, Independent of Supply Voltage . . . 0.7 mA Typ**
- **Common-Mode Input Voltage Range Includes Ground, Allowing Direct Sensing Near Ground**
- **Low Input Bias and Offset Parameters:**
 - Input Offset Voltage . . . 3 mV Typ
A Versions . . . 2 mV Typ
 - Input Offset Current . . . 2 nA Typ
 - Input Bias Current . . . 20 nA Typ
A Versions . . . 15 nA Typ
- **Differential Input Voltage Range Equal to Maximum-Rated Supply Voltage . . . 32 V (26 V for LM2904)**
- **Open-Loop Differential Voltage Amplification . . . 100 V/mV Typ**
- **Internal Frequency Compensation**

LM158, LM158A . . . JG PACKAGE
LM258, LM258A . . . D, DGK, OR P PACKAGE
LM358 . . . D, DGK, P, PS, OR PW PACKAGE
LM358A . . . D, DGK, P, OR PW PACKAGE
LM2904 . . . D, DGK, P, PS, OR PW PACKAGE
(TOP VIEW)

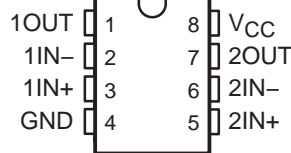

LM158, LM158A . . . FK PACKAGE
(TOP VIEW)

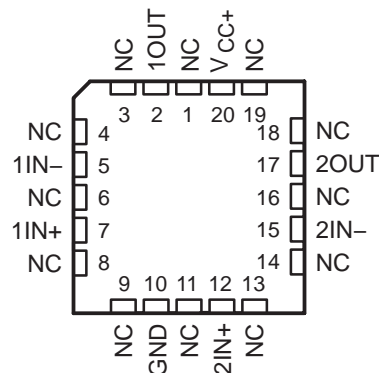

NC – No internal connection

description/ordering information

These devices consist of two independent, high-gain, frequency-compensated operational amplifiers designed to operate from a single supply over a wide range of voltages. Operation from split supplies also is possible if the difference between the two supplies is 3 V to 32 V (3 V to 26 V for the LM2904), and V_{CC} is at least 1.5 V more positive than the input common-mode voltage. The low supply-current drain is independent of the magnitude of the supply voltage.

Applications include transducer amplifiers, dc amplification blocks, and all the conventional operational amplifier circuits that now can be implemented more easily in single-supply-voltage systems. For example, these devices can be operated directly from the standard 5-V supply used in digital systems and easily can provide the required interface electronics without additional ± 5 -V supplies.



Please be aware that an important notice concerning availability, standard warranty, and use in critical applications of Texas Instruments semiconductor products and disclaimers thereto appears at the end of this data sheet.

PRODUCTION DATA information is current as of publication date. Products conform to specifications per the terms of Texas Instruments standard warranty. Production processing does not necessarily include testing of all parameters.

 **TEXAS
INSTRUMENTS**

POST OFFICE BOX 655303 • DALLAS, TEXAS 75265

Copyright © 2004, Texas Instruments Incorporated
On products compliant to MIL-PRF-38535, all parameters are tested unless otherwise noted. On all other products, production processing does not necessarily include testing of all parameters.

**LM158, LM158A, LM258, LM258A
LM358, LM358A, LM2904, LM2904V
DUAL OPERATIONAL AMPLIFIERS**

SLOS068P – JUNE 1976 – REVISED SEPTEMBER 2004

description/ordering information (continued)

ORDERING INFORMATION

T_A	V_{IOmax} AT 25°C	MAX TESTED V_{CC}	PACKAGE†		ORDERABLE PART NUMBER	TOP-SIDE MARKING
0°C to 70°C	7 mV	30 V	PDIP (P)	Tube of 50	LM358P	LM358P
			SOIC (D)	Tube of 75	LM358D	LM358
				Reel of 2500	LM358DR	
			SOP (PS)	Reel of 2000	LM358PSR	L358
			TSSOP (PW)	Tube of 150	LM358PW	L358
				Reel of 2000	LM358PWR	
	MSOP/VSSOP (DGK)	Reel of 2500	LM358DGKR	M5_‡		
	3 mV	30 V	PDIP (P)	Tube of 50	LM358AP	LM358AP
			SOIC (D)	Tube of 75	LM358AD	LM358A
				Reel of 2500	LM358ADR	
			TSSOP (PW)	Tube of 150	LM358APW	L358A
				Reel of 2000	LM358APWR	
MSOP/VSSOP (DGK)			Reel of 2500	LM358ADGKR	M6_‡	
-25°C to 85°C	5 mV	30 V	PDIP (P)	Tube of 50	LM258P	LM258P
			SOIC (D)	Tube of 75	LM258D	LM258
				Reel of 2500	LM258DR	
	MSOP/VSSOP (DGK)	Reel of 2500	LM258DGKR	M2_‡		
	3 mV	30 V	PDIP (P)	Tube of 50	LM258AP	LM258AP
			SOIC (D)	Tube of 75	LM258AD	LM258A
				Reel of 2500	LM258ADR	
	MSOP/VSSOP (DGK)	Reel of 2500	LM258ADGKR	M3_‡		
	-40°C to 125°C	7 mV	26 V	PDIP (P)	Tube of 50	LM2904P
SOIC (D)				Tube of 75	LM2904D	LM2904
				Reel of 2500	LM2904DR	
SOP (PS)				Reel of 2000	LM2904PSR	L2904
TSSOP (PW)				Tube of 150	LM2904PW	L2904
				Reel of 2000	LM2904PWR	
MSOP/VSSOP (DGK)		Reel of 2500	LM2904DGKR	MB_‡		
7 mV		32 V	SOIC (D)	Reel of 2500	LM2904VQDR	L2904V
			TSSOP (PW)	Reel of 2000	LM2904VQPWR	L2904V
2 mV		32 V	SOIC (D)	Reel of 2500	LM2904AVQDR	L2904AV
			TSSOP (PW)	Reel of 2000	LM2904AVQPWR	L2904AV
-55°C to 125°C		5 mV	30 V	CDIP (JG)	Tube of 50	LM158JG
	LCCC (FK)			Tube of 55	LM158FK	LM158FK
	2 mV	30 V	CDIP (JG)	Tube of 50	LM158AJG	LM158AJG
			LCCC (FK)	Tube of 55	LM158AFK	LM158AFK

† Package drawings, standard packing quantities, thermal data, symbolization, and PCB design guidelines are available at www.ti.com/sc/package.

‡ The actual top-side marking has one additional character that designates the assembly/test site.



PACKAGING INFORMATION

Orderable Device	Status ⁽¹⁾	Package Type	Package Drawing	Pins	Package Qty	Eco Plan ⁽²⁾	Lead/Ball Finish	MSL Peak Temp ⁽³⁾
5962-87710012A	ACTIVE	LCCC	FK	20	1	TBD	POST-PLATE	Level-NC-NC-NC
5962-8771001PA	ACTIVE	CDIP	JG	8	1	TBD	A42 SNPB	Level-NC-NC-NC
5962-87710022A	ACTIVE	LCCC	FK	20	1	TBD	POST-PLATE	Level-NC-NC-NC
5962-8771002PA	ACTIVE	CDIP	JG	8	1	TBD	A42 SNPB	Level-NC-NC-NC
LM158AFKB	ACTIVE	LCCC	FK	20	1	TBD	POST-PLATE	Level-NC-NC-NC
LM158AJG	ACTIVE	CDIP	JG	8	1	TBD	A42 SNPB	Level-NC-NC-NC
LM158AJGB	ACTIVE	CDIP	JG	8	1	TBD	A42 SNPB	Level-NC-NC-NC
LM158FKB	ACTIVE	LCCC	FK	20	1	TBD	POST-PLATE	Level-NC-NC-NC
LM158JG	ACTIVE	CDIP	JG	8	1	TBD	A42 SNPB	Level-NC-NC-NC
LM158JGB	ACTIVE	CDIP	JG	8	1	TBD	A42 SNPB	Level-NC-NC-NC
LM258AD	ACTIVE	SOIC	D	8	75	Green (RoHS & no Sb/Br)	CU NIPDAU	Level-1-260C-UNLIM
LM258ADE4	ACTIVE	SOIC	D	8	75	Green (RoHS & no Sb/Br)	CU NIPDAU	Level-1-260C-UNLIM
LM258ADGKR	ACTIVE	MSOP	DGK	8	2500	Green (RoHS & no Sb/Br)	CU NIPDAU	Level-1-260C-UNLIM
LM258ADR	ACTIVE	SOIC	D	8	2500	Green (RoHS & no Sb/Br)	CU NIPDAU	Level-1-260C-UNLIM
LM258ADRE4	ACTIVE	SOIC	D	8	2500	Green (RoHS & no Sb/Br)	CU NIPDAU	Level-1-260C-UNLIM
LM258AP	ACTIVE	PDIP	P	8	50	Pb-Free (RoHS)	CU NIPDAU	Level-NC-NC-NC
LM258APE4	ACTIVE	PDIP	P	8	50	Pb-Free (RoHS)	CU NIPDAU	Level-NC-NC-NC
LM258D	ACTIVE	SOIC	D	8	75	Green (RoHS & no Sb/Br)	CU NIPDAU	Level-1-260C-UNLIM
LM258DE4	ACTIVE	SOIC	D	8	75	Green (RoHS & no Sb/Br)	CU NIPDAU	Level-1-260C-UNLIM
LM258DG4	ACTIVE	SOIC	D	8	75	Green (RoHS & no Sb/Br)	CU NIPDAU	Level-1-260C-UNLIM
LM258DGKR	ACTIVE	MSOP	DGK	8	2500	Green (RoHS & no Sb/Br)	CU NIPDAU	Level-1-260C-UNLIM
LM258DR	ACTIVE	SOIC	D	8	2500	Green (RoHS & no Sb/Br)	CU NIPDAU	Level-1-260C-UNLIM
LM258DRE4	ACTIVE	SOIC	D	8	2500	Green (RoHS & no Sb/Br)	CU NIPDAU	Level-1-260C-UNLIM
LM258DRG4	ACTIVE	SOIC	D	8	2500	Green (RoHS & no Sb/Br)	CU NIPDAU	Level-1-260C-UNLIM
LM258P	ACTIVE	PDIP	P	8	50	Pb-Free (RoHS)	CU NIPDAU	Level-NC-NC-NC
LM258PE4	ACTIVE	PDIP	P	8	50	Pb-Free (RoHS)	CU NIPDAU	Level-NC-NC-NC
LM2904AVQDR	ACTIVE	SOIC	D	8	2500	Pb-Free (RoHS)	CU NIPDAU	Level-2-250C-1 YEAR/ Level-1-235C-UNLIM
LM2904AVQPWR	ACTIVE	TSSOP	PW	8	2000	TBD	CU NIPDAU	Level-1-250C-UNLIM
LM2904D	ACTIVE	SOIC	D	8	75	Green (RoHS & no Sb/Br)	CU NIPDAU	Level-1-260C-UNLIM